



CENTRIFUGAL RECTANGULAR DUCT FAN



Box
Box-I
Box-F
Box-FI

EN

USER'S MANUAL

CONTENTS

Safety requirements.....	3
Purpose.....	5
Delivery set.....	5
Designation key.....	5
Technical data.....	6
Mounting and set-up.....	12
Connection to power mains	13
Technical maintenance.....	17
Troubleshooting.....	19
Storage and transportation regulations.....	19
Manufacturer's warranty	20
Certificate of acceptance.....	21
Seller information	21
Installation certificate.....	21
Warranty card.....	21

This user's manual is a main operating document intended for technical, maintenance, and operating staff.

The manual contains information about purpose, technical details, operating principle, design, and installation of the Box unit and all its modifications.

Technical and maintenance staff must have theoretical and practical training in the field of ventilation systems and should be able to work in accordance with workplace safety rules as well as construction norms and standards applicable in the territory of the country.

SAFETY REQUIREMENTS

All user's manual requirements as well as the provisions of all the applicable local and national construction, electrical, and technical norms and standards must be observed when installing and operating the unit.

Disconnect the unit from the power supply prior to any connection, servicing, maintenance, and repair operations.

Only qualified electricians with a work permit for electrical units up to 1000 V are allowed for installation and maintenance. The present user's manual should be carefully read before beginning works.

Check the unit for any visible damage of the impeller, the casing, and the grille before starting installation. The casing internals must be free of any foreign objects that can damage the impeller blades.

While mounting the unit, avoid compression of the casing! Deformation of the casing may result in motor jam and excessive noise.

Misuse of the unit and any unauthorised modifications are not allowed.

Do not expose the device to adverse atmospheric agents (rain, sun, etc.).

Transported air must not contain any dust or other solid impurities, sticky substances, or fibrous materials.

Do not use the unit in a hazardous or explosive environment containing spirits, gasoline, insecticides, etc.

Do not close or block the intake or extract vents in order to ensure the efficient air flow.

Do not sit on the unit and do not put objects on it.

The information in this user's manual was correct at the time of the document's preparation.

The Company reserves the right to modify the technical characteristics, design, or configuration of its products at any time in order to incorporate the latest technological developments.

Never touch the unit with wet or damp hands.

Never touch the unit when barefoot.

The installation site of the fan must have protective elements that prevent foreign objects from entering the fan.

When starting, setting up and operating the fan, the exhaust and supply spigots must be protected to prevent injury from the rotating parts of the fan.

This appliance is not intended for use by persons (including children) with reduced physical, sensory or mental capabilities, or lack of experience and knowledge, unless they have been given supervision or instruction concerning use of the appliance by a person responsible for their safety.

Children should be supervised to ensure that they do not play with the appliance.

The connection to the supply mains must be made through a means of disconnection, which is incorporated in the fixed wiring in accordance with the wiring rules, and has a contact separation in all poles that allows for full disconnection under overvoltage category III conditions.

If the supply cord is damaged, it must be replaced by the manufacturer, its service agent, or similarly qualified persons in order to avoid a safety hazard.

Ensure that the appliance is switched off from the supply mains before removing the guard.

WARNING: If there are any unusual oscillating movements, immediately stop using the appliance and contact the manufacturer, its service agent or suitably qualified persons.

The replacement of parts of the safety suspension system device shall be performed by the manufacturer, its service agent or suitably qualified persons.

Fixing means for attachment to the ceiling such as hooks or other devices shall be fixed with a sufficient strength to withstand 4 times the weight of the appliance.

The mounting of the suspension system shall be performed by the manufacturer, its service agent or suitably qualified persons.

The appliance is to be installed so that the blades are more than 2.3m above the floor.

Precautions must be taken to avoid the back-flow of gases into the room from the open flue of gas or other fuel-burning appliances.



**THE PRODUCT MUST BE DISPOSED SEPARATELY AT THE END OF ITS SERVICE LIFE.
DO NOT DISPOSE THE UNIT AS UNSORTED DOMESTIC WASTE.**

PURPOSE



THE UNIT SHOULD NOT BE OPERATED BY CHILDREN OR PERSONS WITH REDUCED PHYSICAL, MENTAL, OR SENSORY CAPACITIES, OR THOSE WITHOUT THE APPROPRIATE TRAINING.

THE UNIT MUST BE INSTALLED AND CONNECTED ONLY BY PROPERLY QUALIFIED PERSONNEL AFTER THE APPROPRIATE BRIEFING.

THE CHOICE OF UNIT INSTALLATION LOCATION MUST PREVENT UNAUTHORISED ACCESS BY UNATTENDED CHILDREN.

The duct rectangular fan is designed for supply and exhaust ventilation of domestic, public and industrial premises with high requirements to the noise level and with limited space for mounting.

The unit is rated for continuous operation.

The unit is a component part and is not designed for stand-alone operation.

Transported air must not contain any flammable or explosive mixtures, evaporation of chemicals, sticky substances, fibrous materials, coarse dust, soot and oil particles or environments favourable for the formation of hazardous substances (toxic substances, dust, pathogenic germs).

DELIVERY SET

NAME	NUMBER
Fan	1 pc.
User's manual	1 pc.
Packing box	1 pc.

DESIGNATION KEY

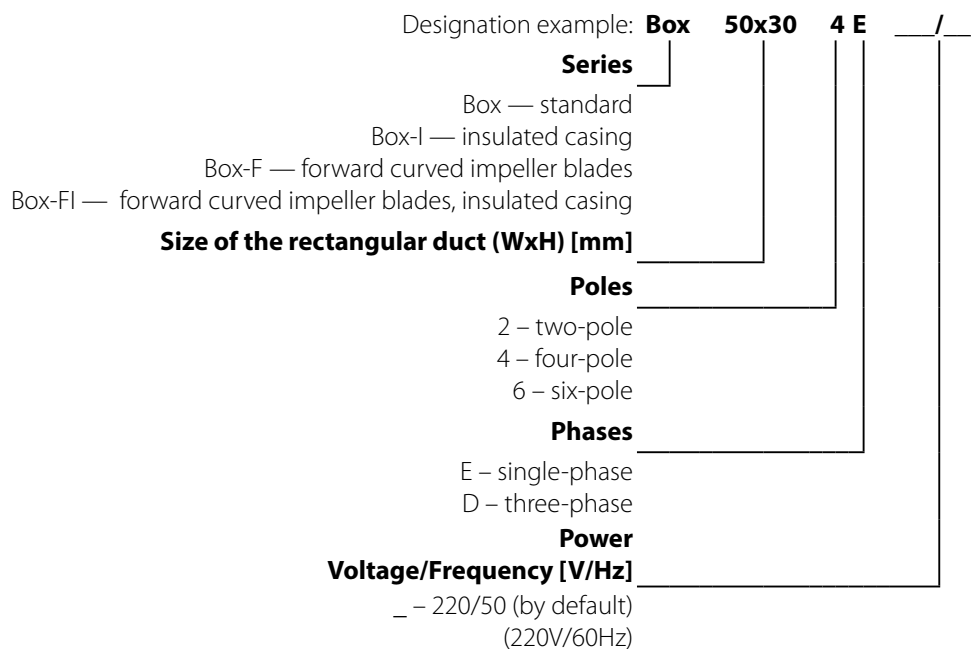

TECHNICAL DATA

The unit is designed for indoor application with the ambient temperature ranging from 0 °C up +45 °C and relative humidity up to 80 %. The unit is rated as a Class I electrical appliance.

The unit design is constantly being improved, thus some models may be slightly different from those described in this manual.

Box/Box-I	40x20 2E		50x25 2E		50x30 4E		50x30 4D	
Voltage [V]	1~ 220-240		1~ 220-240		1~ 220-240		3~ 400	
Frequency [Hz]	50	60	50	60	50	60	50	60
Power [W]	138	200	305	380	140	175	136	165
Current [A]	0.60	0.88	1.32	1.65	0.57	0.73	0.34	0.53
Maximum air flow [m ³ /h]	930	1070	1720	1850	1700	1855	1380	1620
RPM [min ⁻¹]	2600	2850	2550	2830	1390	1530	1360	1600
Sound pressure level at 3 m distance [dBA]	69/61*	71/63*	76/65*	78/67*	53/45*	55/46*	53/45*	55/46*
Transported air temperature [°C]	-25...+45	-25...+45	-25...+45	-25...+45	-25...+45	-25...+50	-25...+65	-25...+55
Ingress protection rating of the unit	IPX4	IPX4	IPX4	IPX4	IPX4	IPX4	IPX4	IPX4
Electric motor IP rating	IP44	IP44	IP44	IP44	IP54	IP54	IP54	IP54

Box/Box-I	60x30 4E		60x30 4D		60x35 4E	
Voltage [V]	1~ 220-240		3~ 400		1~ 220-240	
Frequency [Hz]	50	60	50	60	50	60
Power [W]	220	310	230	235	470	700
Current [A]	0.9	1.38	0.52	0.53	2.37	3.15
Maximum air flow [m ³ /h]	2470	2510	2530	2630	2950	3515
RPM [min ⁻¹]	1400	1450	1360	1600	1370	1460
Sound pressure level at 3 m distance [dBA]	55/47*	55/57*	53/46*	53/46*	67/59*	68/59*
Transported air temperature [°C]	-25...+45	-25...+45	-25...+70	-25...+65	-40...+80	-40...+55
Ingress protection rating of the unit	IPX4	IPX4	IPX4	IPX4	IPX4	IPX4
Electric motor IP rating	IP54	IP54	IP54	IP54	IP54	IP54

Box/Box-I	60x35 4D				10x50 4D
Voltage [V]	3~ 400 Δ		3~ 400 Y		3~ 400
Frequency [Hz]	50	60	50	60	50
Power [W]	510	750	380	515	3800
Current [A]	1.41	1.44	0.7	0.93	6.6
Maximum air flow [m ³ /h]	2970	3410	2660	2730	15000
RPM [min ⁻¹]	1415	1610	1235	1220	1360
Sound pressure level at 3 m distance [dBA]	64/55*	64/55*	63/55*	63/55*	70
Transported air temperature [°C]	-40...+60	-40...+60	-40...+80	-40...+40	-25...+40
Ingress protection rating of the unit	IPX4	IPX4	IPX4	IPX4	IPX4
Electric motor IP rating	IP54	IP54	IP54	IP54	IP54

* Parameters for a Box-I model.

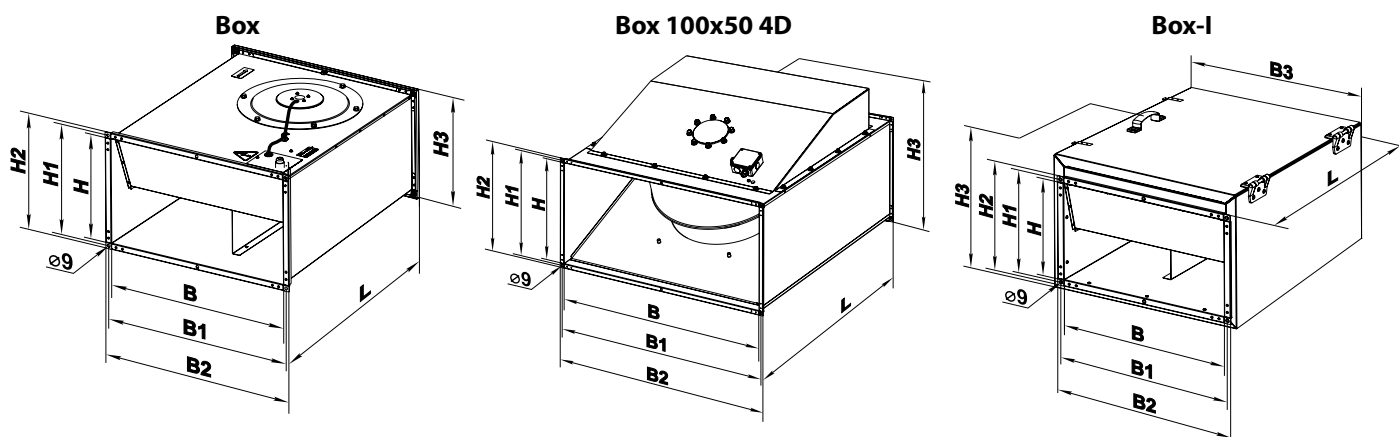

Model	Dimensions [mm]								Weight [kg]
	B	B1	B2	H	H1	H2	H3	L	
Box 40x20 2E	400	420	440	200	220	240	240	500	11.25
Box 50x25 2E	500	520	540	250	270	290	290	640	17.88
Box 50x30 4E	500	520	540	300	320	340	340	680	19.80
Box 50x30 4D	500	520	540	300	320	340	340	680	19.80
Box 60x30 4E	600	620	640	300	320	340	342	680	27.77
Box 60x30 4D	600	620	640	300	320	340	342	680	27.77
Box 60x35 4E	600	620	640	350	370	390	390	735	36.38
Box 60x35 4D	600	620	640	350	370	390	390	735	36.38

Model	Dimensions [mm]								Weight [kg]
	B	B1	B2	H	H1	H2	H3	L	
Box 100x50 4D	1000	1020	1040	500	520	540	720	1150	126.0

Model	Dimensions [mm]									Weight [kg]
	B	B1	B2	B3	H	H1	H2	H3	L	
Box-I 40x20 2E	400	420	440	500	200	220	240	360	500	24.5
Box-I 50x25 2E	500	520	540	600	250	270	290	410	640	27.6
Box-I 50x30 4E	500	520	540	600	300	320	340	460	680	37.2
Box-I 50x30 4D	500	520	540	600	300	320	340	460	680	37.2
Box-I 60x30 4E	600	620	640	700	300	320	340	460	680	43.5
Box-I 60x30 4D	600	620	640	700	300	320	340	460	680	43.5
Box-I 60x35 4E	600	620	640	700	350	370	390	530	735	56.2
Box-I 60x35 4D	600	620	640	700	350	370	390	530	735	56.2

Box-F/Box-FI	40x20 4E	40x20 4D	50x25 4E	50x25 4D	50x25 6E
Unit voltage [V/50 (60) Hz]	1~ 230	3~ 400	1~ 230	3~ 400	1~ 230
Power [W]	295	282	535	570	244
Current [A]	1.32	0.60	2.49	0.94	1.22
Maximum air flow [m ³ /h]	1440	1470	1750	1850	1460
RPM [min ⁻¹]	1350	1300	1250	1270	910
Sound pressure level at 3 m distance [dBA]	50/42*	52/43*	53/44*	54/44*	45/37*
Transported air temperature [°C]	-25...+40	-25...+45	-20...+40	-20...+40	-20...+50
Ingress protection rating of the unit	IPX4	IPX4	IPX4	IPX4	IPX4
Electric motor IP rating	IP54	IP54	IP54	IP54	IP54

Box-F/Box-FI	50x25 6D	50x30 4E	50x30 4D	50x30 6E	50x30 6D
Unit voltage [V/50 (60) Hz]	3~ 400	1~ 230	3~ 400	1~ 230	3~ 400
Power [W]	274	710	855	283	303
Current [A]	0.67	3.10	1.70	1.59	0.8
Maximum air flow [m ³ /h]	1490	2350	2350	1550	1620
RPM [min ⁻¹]	930	1230	1300	890	910
Sound pressure level at 3 m distance [dBA]	45/38*	57/47*	56/47*	47/39*	51/41*
Transported air temperature [°C]	-20...+60	-25...+70	-20...+50	-20...+70	-20...+60
Ingress protection rating of the unit	IPX4	IPX4	IPX4	IPX4	IPX4
Electric motor IP rating	IP54	IP54	IP54	IP54	IP54

Box-F/Box-FI	60x30 4E	60x30 4D	60x30 6E	60x30 6D	60x35 4E
Unit voltage [V/50 (60) Hz]	1~ 230	3~ 400	1~ 230	3~ 400	1~ 230
Power [W]	1240	1560	419	397	2840
Current [A]	6.45	2.73	2.05	0.78	13.90
Maximum air flow [m ³ /h]	2950	3740	2260	2320	4260
RPM [min ⁻¹]	1210	1310	870	920	1260
Sound pressure level at 3 m distance [dBA]	59/51*	57/50*	50/42*	49/41*	59/51*
Transported air temperature [°C]	-25...+50	-25...+65	-20...+70	-20...+70	-20...+40
Ingress protection rating of the unit	IPX4	IPX4	IPX4	IPX4	IPX4
Electric motor IP rating	IP54	IP54	IP54	IP54	IP54

* Parameters for a Box-FI model.

Box-F/Box-FI	60x35 4D	60x35 6E	60x35 6D	70x40 4D
Unit voltage [V/50 (60) Hz]	3~ 400	1~ 230	3~ 400	3~ 400
Power [W]	2460	720	743	3630
Current [A]	3.93	3.6	1.47	6.00
Maximum air flow [m ³ /h]	5020	2755	3310	6450
RPM [min ⁻¹]	1300	820	940	1320
Sound pressure level at 3 m distance [dBA]	60/52*	51/43*	55/46*	65/56*
Transported air temperature [°C]	-20...+40	-20...+60	-20...+70	-25...+40
Ingress protection rating of the unit	IPX4	IPX4	IPX4	IPX4
Electric motor IP rating	IP54	IP54	IP54	IP54

Box-F/Box-FI	60x35 4D	60x35 6E	60x35 6D	70x40 4D
Unit voltage [V/50 (60) Hz]	3~ 400	1~ 230	3~ 400	3~ 400
Power [W]	2460	720	743	3630
Current [A]	3.93	3.6	1.47	6.00
Maximum air flow [m ³ /h]	5020	2755	3310	6450
RPM [min ⁻¹]	1300	820	940	1320
Sound pressure level at 3 m distance [dBA]	60/52*	51/43*	55/46*	65/56*
Transported air temperature [°C]	-20...+40	-20...+60	-20...+70	-25...+40
Ingress protection rating of the unit	IPX4	IPX4	IPX4	IPX4
Electric motor IP rating	IP54	IP54	IP54	IP54

Box-F/Box-FI	70x40 6D	80x50 4D	80x50 6D	80x50 8D
Unit voltage [V/50 (60) Hz]	3~ 400	3~ 400	3~ 400	3~ 400
Power [W]	1150	5850	2790	1377
Current [A]	2.3	9.35	5.18	3.40
Maximum air flow [m ³ /h]	4050	8120	7610	5620
RPM [min ⁻¹]	890	1140	830	710
Sound pressure level at 3 m distance [dBA]	58/49*	67/61*	59/53*	58/49
Transported air temperature [°C]	-20...+70	-25...+40	-20...+50	-20...+40
Ingress protection rating of the unit	IPX4	IPX4	IPX4	IPX4
Electric motor IP rating	IP54	IP54	IP54	IP54

Box-F/Box-FI	90x50 6D	90x50 8D	10x50 6D	10x50 8D
Unit voltage [V/50 (60) Hz]	3~ 400	3~ 400	3~ 400	3~ 400
Power [W]	3870	2000	3870	2000
Current [A]	7.0	4.1	7.0	4.1
Maximum air flow [m ³ /h]	9540	7175	9540	7175
RPM [min ⁻¹]	930	680	930	680
Sound pressure level at 3 m distance [dBA]	61/55*	59/50*	61/55*	59/51*
Transported air temperature [°C]	-20...+55	-20...+40	-20...+55	-20...+40
Ingress protection rating of the unit	IPX4	IPX4	IPX4	IPX4
Electric motor IP rating	IP54	IP54	IP54	IP54

* Parameters for a Box-FI model.

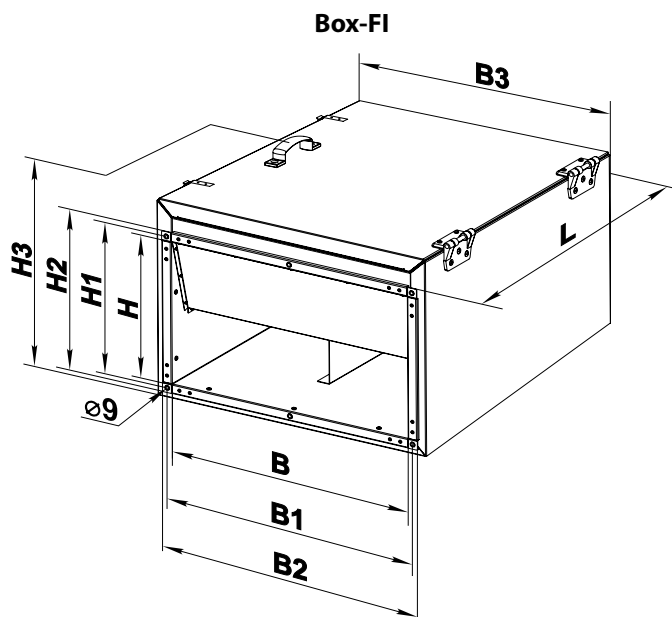
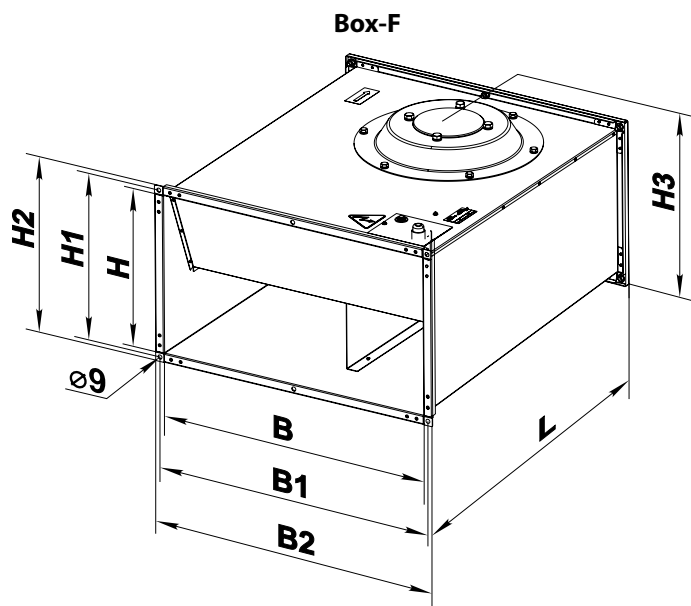

Model	Dimensions [mm]								Weight [kg]
	B	B1	B2	H	H1	H2	H3	L	
Box-F 40x20 4E	400	420	440	200	220	240	255	500	17.5
Box-F 40x20 4D	400	420	440	200	220	240	255	500	17.5
Box-F 50x25 4E	500	520	540	250	270	290	335	640	24
Box-F 50x25 4D	500	520	540	250	270	290	335	640	24
Box-F 50x25 6E	500	520	540	250	270	290	335	640	24
Box-F 50x25 6D	500	520	540	250	270	290	335	640	24
Box-F 50x30 4E	500	520	540	300	320	340	365	680	33
Box-F 50x30 4D	500	520	540	300	320	340	365	680	33
Box-F 50x30 6E	500	520	540	300	320	340	365	680	33
Box-F 50x30 6D	500	520	540	300	320	340	365	680	33
Box-F 60x30 4E	600	620	640	300	320	340	375	680	35
Box-F 60x30 4D	600	620	640	300	320	340	375	680	35
Box-F 60x30 6E	600	620	640	300	320	340	375	680	35
Box-F 60x30 6D	600	620	640	300	320	340	375	680	35
Box-F 60x35 4E	600	620	640	350	370	390	425	735	49.5
Box-F 60x35 4D	600	620	640	350	370	390	425	735	49.5
Box-F 60x35 6E	600	620	640	350	370	390	425	735	49.5
Box-F 60x35 6D	600	620	640	350	370	390	425	735	49.5
Box-F 70x40 4D	700	720	740	400	420	440	480	780	60
Box-F 70x40 6D	700	720	740	400	420	440	480	780	56
Box-F 80x50 4D	800	820	840	500	520	540	580	820	74
Box-F 80x50 6D	800	820	840	500	520	540	580	820	70
Box-F 80x50 8D	800	820	840	500	520	540	580	820	70
Box-F 90x50 6D	900	920	940	500	520	540	580	954	90
Box-F 90x50 8D	900	920	940	500	520	540	580	954	90
Box-F 10x50 6D	1000	1020	1040	500	520	540	580	954	95
Box-F 10x50 8D	1000	1020	1040	500	520	540	580	954	95

Model	Dimensions [mm]									Weight [kg]
	B	B1	B2	B3	H	H1	H2	H3	L	
Box-FI 40x20 4E	400	420	440	470	200	220	240	360	500	29
Box-FI 40x20 4D	400	420	440	470	200	220	240	360	500	29
Box-FI 50x25 4E	500	520	540	570	250	270	290	410	640	40.5
Box-FI 50x25 4D	500	520	540	570	250	270	290	410	640	40.5
Box-FI 50x25 6E	500	520	540	570	250	270	290	410	640	40.5
Box-FI 50x25 6D	500	520	540	570	250	270	290	410	640	40.5
Box-FI 50x30 4E	500	520	540	570	300	320	340	460	680	52.5
Box-FI 50x30 4D	500	520	540	570	300	320	340	460	680	52.5
Box-FI 50x30 6E	500	520	540	570	300	320	340	460	680	52.5
Box-FI 50x30 6D	500	520	540	570	300	320	340	460	680	52.5
Box-FI 60x30 4E	600	620	640	670	300	320	340	480	680	56
Box-FI 60x30 4D	600	620	640	670	300	320	340	480	680	56
Box-FI 60x30 6E	600	620	640	670	300	320	340	480	680	56
Box-FI 60x30 6D	600	620	640	670	300	320	340	480	680	56
Box-FI 60x35 4E	600	620	640	670	350	370	390	530	735	72
Box-FI 60x35 4D	600	620	640	670	350	370	390	530	735	72
Box-FI 60x35 6E	600	620	640	670	350	370	390	530	735	72
Box-FI 60x35 6D	600	620	640	670	350	370	390	530	735	72
Box-FI 70x40 4D	700	720	–	800	400	420	–	620	880	103
Box-FI 70x40 6D	700	720	–	800	400	420	–	620	880	99
Box-FI 80x50 6D	800	820	–	900	500	520	–	720	935	120
Box-FI 80x50 4D	800	820	–	900	500	520	–	720	935	127
Box-FI 80x50 8D	800	820	–	900	500	520	–	720	935	120
Box-FI 90x50 6D	900	920	–	1000	500	520	–	720	1000	142
Box-FI 90x50 8D	900	920	–	1000	500	520	–	720	1000	142
Box-FI 10x50 6D	1000	1020	–	1100	500	520	–	720	1000	150
Box-FI 10x50 8D	1000	1020	–	1100	500	520	–	720	1000	150

MOUNTING AND SET-UP



BEFORE MOUNTING MAKE SURE THE CASING DOES NOT CONTAIN ANY FOREIGN OBJECTS (E.G. FOIL, PAPER).



WHILE INSTALLING THE UNIT ENSURE CONVENIENT ACCESS FOR SUBSEQUENT MAINTENANCE AND REPAIR.

The fan can operate at any position.

When positioned under the ceiling, it is advisable to mount the fan with the motor cover downwards for easy access to the terminal box and the motor.

Check the fan power cables for integrity and make sure the impeller has smooth rotation prior to mounting.

Install flexible connectors on both sides of the fan.

Mount the fan in such a way that the arrow on the fan casing matches the air flow direction in the system.

The fan should always be installed on its own hangers so that it does not load the flexible connectors and the connected air ducts.

The most suitable mounting option is fixing the unit to the ceiling with anchors or suspending it on perforated metal plates.

Before mounting, apply a self-adhesive seal to the end surfaces of the fan.

Connect the fan to the air ducts with M8 bolts and nuts.

Since the fan belongs to Class 1 in terms of electrical hazard protection proper grounding is a must:

⊕ the PE terminal must be connected to the protective ground.

The fan design is constantly being improved, thus some models may be slightly different from those described in this manual.

VARIANT OF FAN MOUNTING BETWEEN SEGMENTS OF RECTANGULAR AIR DUCTS

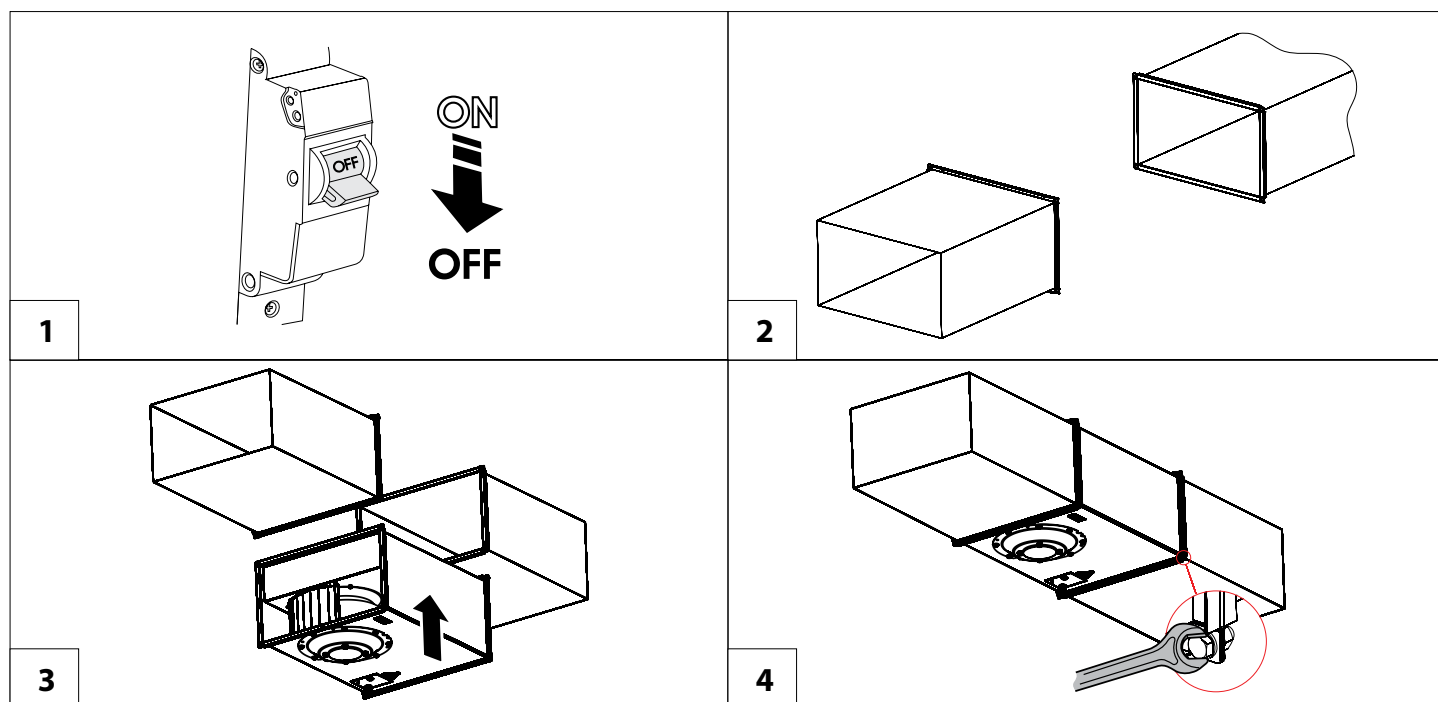

CONNECTION TO POWER MAINS



DISCONNECT THE POWER SUPPLY PRIOR TO ANY OPERATIONS WITH THE UNIT.

CONNECTION OF THE UNIT TO POWER MAINS IS ALLOWED BY A QUALIFIED ELECTRICIAN WITH A WORK PERMIT FOR THE ELECTRIC UNITS UP TO 1000 V AFTER CAREFUL READING OF THE PRESENT USER'S MANUAL.

THE RATED ELECTRICAL PARAMETERS OF THE UNIT ARE GIVEN ON THE MANUFACTURER'S LABEL.

Depending on the fan type it is rated for connection either to single-phase AC 230 V/50/60 Hz or three-phase AC 380-400 V/50/60 Hz power mains.

The connection must be made using durable, insulated and heat-resistant conductors (cables, wires).

The external lead-in must be equipped with a circuit breaker built into the stationary wiring to disconnect all the mains phases.

The QF external circuit breaker location must ensure free access for quick shutdown of the fan.

The trip current must be in compliance with current consumption.

The recommended rated current of the circuit breaker and the conductor cross section for various types of fans are shown in the table.

The given conductor cross sections are for reference only.

The actual conductor cross-section selection must be based on its type, the maximum permissible heating, insulation, length and installation method (in the air, pipes or inside walls).

The recommended type of circuit breakers is D or C, but with replacement to D or to a higher rating in case of tripping because of frequent start-ups.

The recommended circuit breaker rated current and conductor cross section

Model	Rated current of the circuit breaker	Recommended cable, n x S, where n is the number of wires, and S is the cross section in mm ²
Box, Box-I 40x20 2E	3	3 x 0.75
Box, Box-I 50x25 2E	6	3 x 0.75
Box, Box-I 50x30 4E	2	3 x 0.75
Box, Box-I 50x30 4D	2	5 x 0.75
Box, Box-I 60x30 4E	4	5 x 0.75
Box, Box-I 60x30 4D	2	5 x 0.75
Box, Box-I 60x35 4E	10	3 x 1
Box, Box-I 60x35 4D	4	5 x 0.75
Box 100x50 4D	20	5 x 1.5
Box-F, Box-FI 40x20 4E	4	3 x 0.75
Box-F, Box-FI 40x20 4D	2	5 x 0.75
Box-F, Box-FI 50x25 4E	10	3 x 1
Box-F, Box-FI 50x25 4D	4	5 x 0.75
Box-F, Box-FI 50x30 4E	4	3 x 0.75
Box-F, Box-FI 50x30 4D	2	5 x 0.75
Box-F, Box-FI 60x30 4E	10	3 x 1.5
Box-F, Box-FI 60x30 4D	6	5 x 0.75
Box-F, Box-FI 60x35 4E	6	3 x 2.5
Box-F, Box-FI 60x35 4D	3	5 x 1.0
Box-F, Box-FI 70x40 4D	20	5 x 1.5
Box-F, Box-FI 80x50 4D	10	5 x 1.5
Box-F, Box-FI 80x50 6D	10	5 x 1.0
Box-F, Box-FI 90x50 6D	3	5 x 1.5
Box-F, Box-FI 10x50 6D	40	5 x 2.5

Wiring diagram for Box/Box-I 40x20 2E;
 Box/Box-I 50x25 2E; Box/Box-I 50x30 4E;
 Box/Box-I 60x30 4E; Box/Box-I 60x35 4E units with a single-phase motor

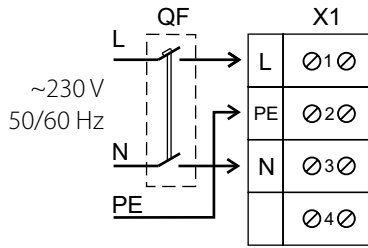

Wiring diagram for Box/Box-I 50x30 4D units (first option) with a three-phase motor

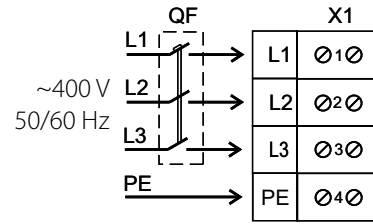

Wiring diagram for Box/Box-I 50x30 4D (second option),
 Box/Box-I 60x30 4D units with a three-phase motor

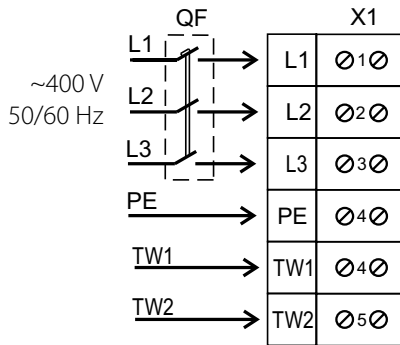

Wiring diagram for Box/Box-I 60x35 4D units with a three-phase motor

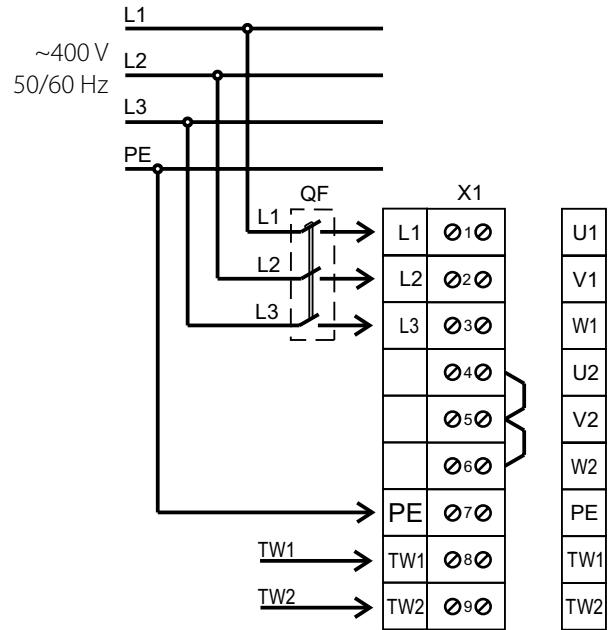

Wiring diagram for Box-F, Box-FI fans with a single-phase motor

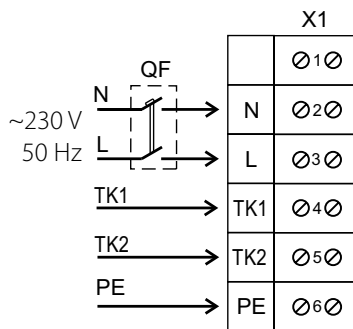

Wiring diagram for Box-F, Box-FI fans with a three-phase motor

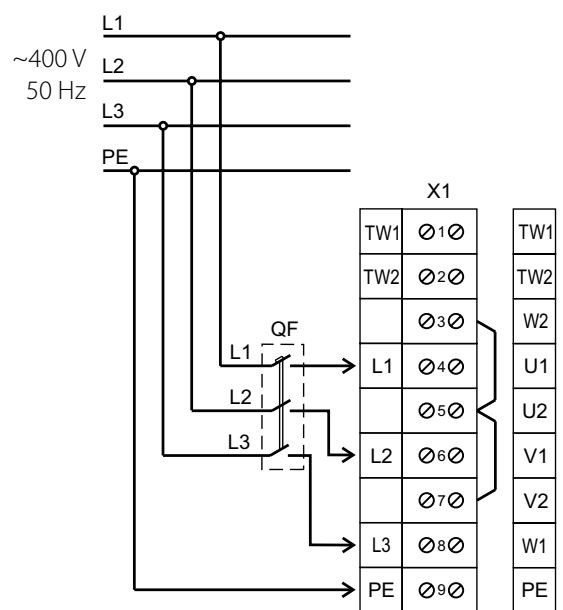

* X1 – terminal block, QF – automatic circuit breaker (not included in the delivery set).

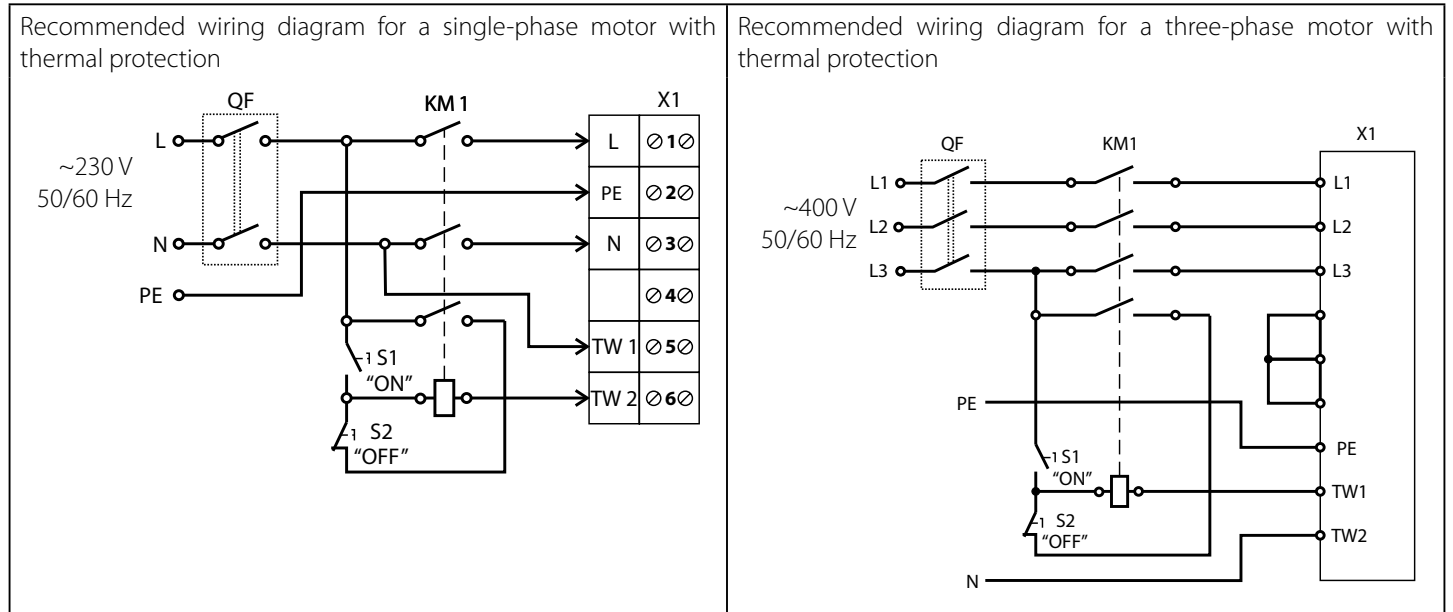

X1 – terminal block, QF – circuit breaker, KM1 – magnetic starter, S1, S2 – control buttons (QF, KM1, S1, S2 are not included in the delivery set)

The TW1, TW2 (TK1, TK2) are the electrical leads of the normally closed contact of the motor overheating protection. Connect the contact in series to power circuit of the magnetic starter coil KM1 that starts the motor after pressing the S1 button. After the motor overheating the contact gets broken and switches the starter coil off to cut power off and stop the motor. The QF circuit breaker, the magnetic starter KM1, the control knobs S1 and S2 are not included in the delivery set and must be installed by the user.

Box, Box-I, Box-F, Box-FI 40x20, 50x25, 50x30, 60x30, 60x35

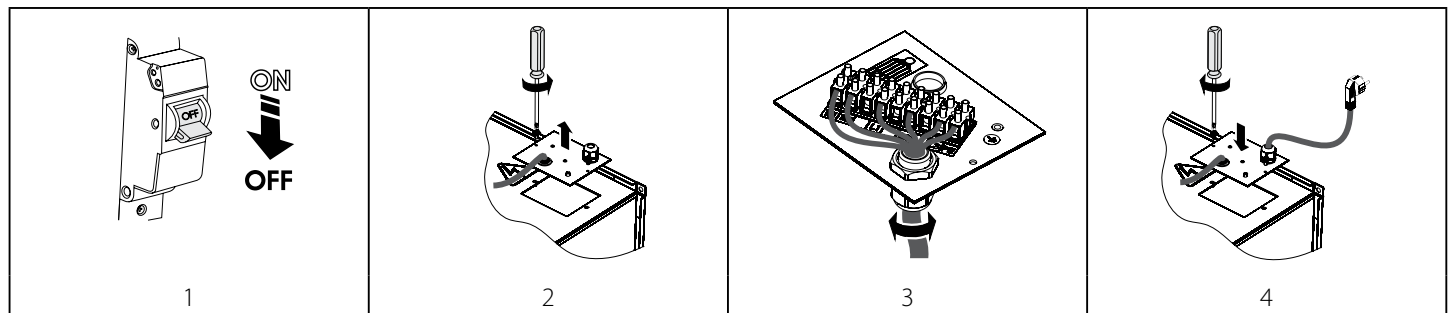

Box-F, Box-FI 70x40, 80x50, 90x50, 10x50

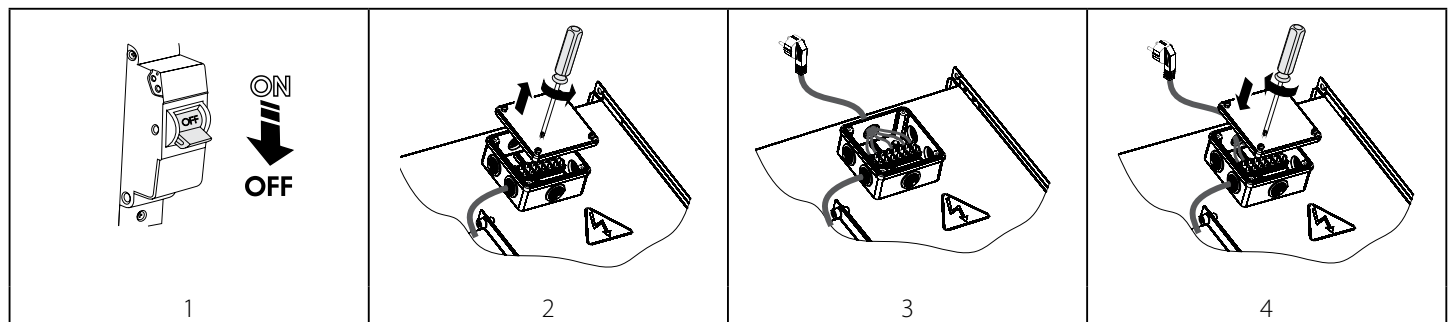

ASYNCHRONOUS ELECTRIC MOTOR STARTING METHODS

There are several methods for starting asynchronous squirrel-cage electric motors.

The most common methods are: direct-on-line (DOL), with a soft starter (SS) or with a frequency converter (FC).

Direct-on-line starting

In case of direct-on-line starting (i.e. by connecting the motor to the electric mains with a simple line contactor), the motor starting time significantly increases due to high inertia of the impeller, which, in turn, results in high in-rush starting currents in the circuit. These currents of long duration may cause voltage slumps (especially if the feed line section falls short of the requirements), which may affect load operation.

The in-rush current consumed by an electric motor in case of DOL starting is 5-8 times larger than the rated value (or even 10-14 times larger in some rare instances). It should be noted that the torque developed by the motor also significantly exceeds the rated value.

Upon energisation the motor operates as a transformer with a squirrel-cage secondary winding formed by the rotor cage with a very low resistance.

The rotor develops high induced current causing a rush of current in the feed line.

The startup torque during starting averages 0.5-1.5 of the rated torque value.

Despite such advantages as simple construction, high startup current, quick start and low cost, direct-on-line systems are suitable only in the following cases:

- the motor power is low compared to the mains power which limits the adverse effect of the rush of current
- the driven mechanism does not require gradual speed build-up or is equipped with a damping device to smooth out the inrush
- the high startup torque has no adverse effects on the operation of the driven mechanism

Soft start. SS starting.

A soft starter gradually increases the voltage supplied to the motor – from the initial to the rated value.

This starting system can be used to meet the following goals:

- limit the motor current
- regulate the torque

Regulation by limiting the current sets the maximum in-rush current equal to 300-400 % (or 250 % in some rare instances) of the rated current and reduces torque characteristics. This type of regulation is especially suited for turbomachinery such as centrifugal pumps and fans.

Regulation by variation of torque optimizes the torque during startup and reduces in-rush current in the circuit. These conditions are suitable for mechanisms with constant load resistance.

This type of soft starting may differ in the implementation pattern:

- motor start
- motor start and stop
- device bridging at the end of start sequence
- start and stop of several motors in stage circuits

Soft start. FC starting.

During the starting the FC raises the frequency from 0 Hz to the electrical mains frequency (50 or 60 Hz). As the frequency is increased gradually, the motor can be assumed to operate at its rated speed for a given frequency value. Furthermore, on the assumption that the motor runs at its rated speed the nominal torque should be immediately available whereas the current will be approximately equal to the rated value.

This starting system is used for speed control and regulation and can be used in the following cases:

- start with high-inertia load
- start with high load and limited-capacity power supply source
- optimization of electric power consumption depending on turbomachinery speed

The aforementioned starting system can be used for all types of mechanisms.

Problems associated with DOL starting

The problems caused by DOL starting may be divided into two groups:

1. An abrupt start causes mechanical shock, jolts in the mechanism, shock removal of free play etc.
2. A heavy start cannot be completed.

Let us review three variations of a heavy start:

1. The feed line performance is barely sufficient or insufficient to maintain the induced current.

Typical symptoms: Upon starting the circuit breakers at the system input are tripped; the lights, certain relays and contactors go off, and the supply generator shuts down.

Solution: In the best-case scenario an SS device may help reduce the in-rush current to 250 % of the motor rated current. If this is insufficient, an FC is necessary.

2. The motor cannot start the mechanism with DOL starting.

Typical symptoms: The motor fails to turn or "freezes" at certain speed which is maintained until actuation of the protection suite.

Solution: This problem may not be solved with an SS device. The motor develops insufficient shaft torque. However, this problem can be addressed by using an FC, but each case may be different.

3. The motor spins up the mechanism with authority, but fails to reach the rated rotation speed.

Typical symptoms: The input automatic circuit breaker is tripped during spin-up. This often happens with heavy-weight fans with a considerable rotation speed.

Solution: Such problems may be addressed with an SS device, but not with 100 % certainty. The closer the motor speed to the rated value during the actuation of the protective equipment, the higher the chances of success. The use of an FC in this case helps solve the problem fundamentally.

Standard switching equipment (automatic circuit breakers, contactors and motor starters) is not designed to withstand prolonged overloads normally causing the fan to shut down automatically DOL starting that continues for a long period of time.

Using switching equipment with a higher maximum current rating renders the electric motor protection system less sensitive. As a result the switching equipment will not be able to detect motor overload in time due to a high current sensing threshold.

Such problems as mentioned above can only be addressed by utilizing a soft starter or a frequency converter to start the fan.



MAKE SURE THAT THE FAN IMPELLER ROTATES IN THE DIRECTION MARKED BY THE ARROW ON THE FAN CASING.

IF NECESSARY, CHANGE THE IMPELLER ROTATION DIRECTION BY ALTERING THE PHASE SEQUENCE ON THE ELECTRIC MOTOR TERMINALS.

TECHNICAL MAINTENANCE



DISCONNECT THE UNIT FROM POWER SUPPLY BEFORE ANY MAINTENANCE OPERATIONS!

Prior to performing any technical maintenance and repair disconnect the fan from the electric mains and wait until its rotating parts come to a complete stop.

The technical maintenance includes periodic cleaning of the surfaces from accumulated dust and dirt.

Use a soft brush or compressed air to remove dust from metal surfaces of the fan. Use a vacuum cleaner to remove dust from the sound insulating surface.

The impeller blades require thorough cleaning once in 6 months.

Detach air ducts from the fan before starting maintenance works.

Clean the impeller blades with a soft cloth wetted in mild water detergent solution. Avoid liquid dripping on the motor.

Wipe the fan surfaces dry after cleaning.

While cleaning the fan make sure the balance counterweights are not shifted and the impeller is not misaligned.

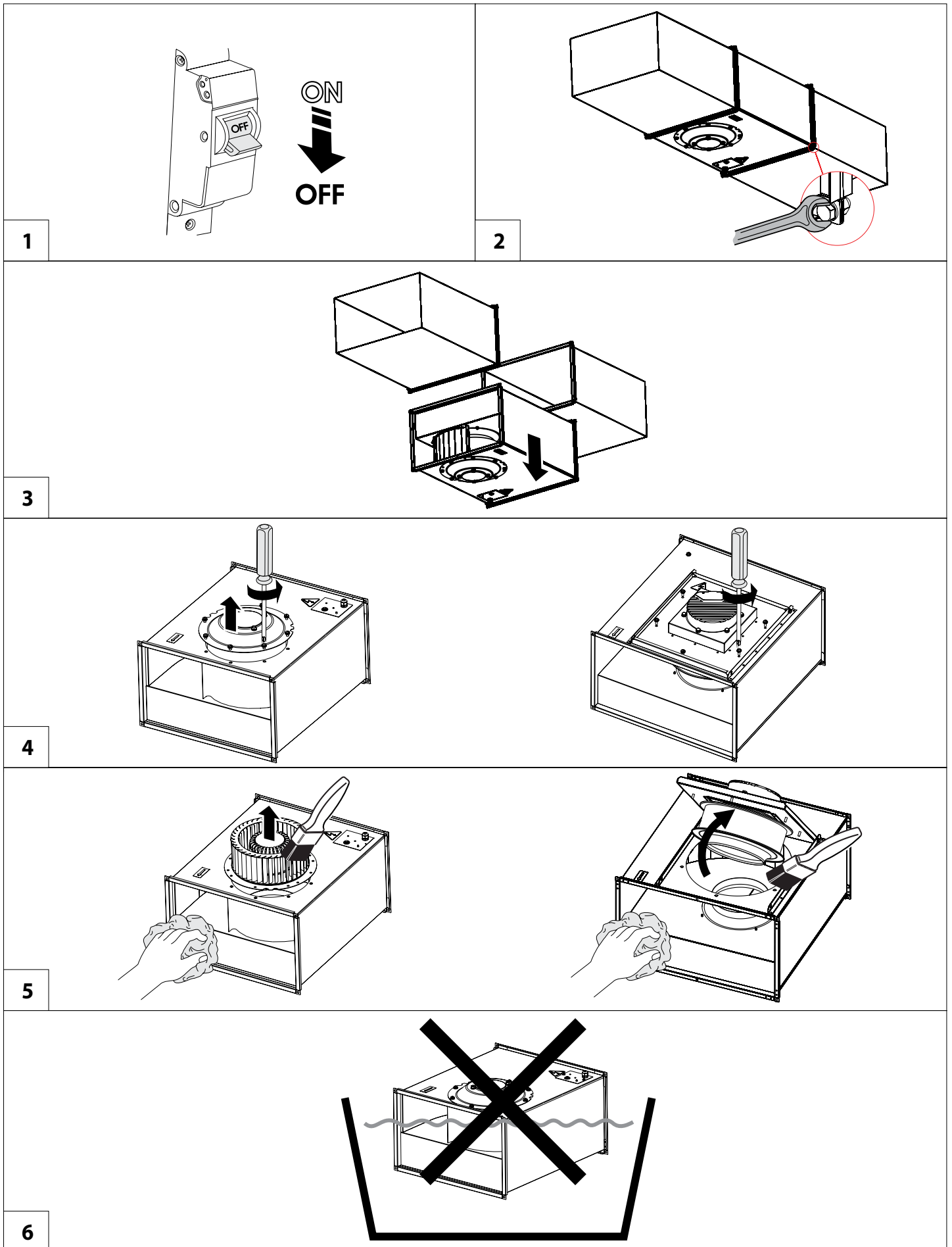

TROUBLESHOOTING

Problem	Possible reasons	Troubleshooting
The fan does not run.	No power supply.	Check the automatic circuit breaker. Check the electric connections.
Noisy operation.	Impeller imbalance.	Clean the impeller.

STORAGE AND TRANSPORTATION REGULATIONS

- Store the unit in the manufacturer's original packaging box in a dry closed ventilated premise with temperature range from +5 °C to +40 °C and relative humidity up to 70 %.
- Storage environment must not contain aggressive vapors and chemical mixtures provoking corrosion, insulation, and sealing deformation.
- Use suitable hoist machinery for handling and storage operations to prevent possible damage to the unit.
- Follow the handling requirements applicable for the particular type of cargo.
- The unit can be carried in the original packaging by any mode of transport provided proper protection against precipitation and mechanical damage. The unit must be transported only in the working position.
- Avoid sharp blows, scratches, or rough handling during loading and unloading.
- Prior to the initial power-up after transportation at low temperatures, allow the unit to warm up at operating temperature for at least 3-4 hours.

MANUFACTURER'S WARRANTY

The product is in compliance with EU norms and standards on low voltage guidelines and electromagnetic compatibility. We hereby declare that the product complies with the provisions of Electromagnetic Compatibility (EMC) Directive 2014/30/EU of the European Parliament and of the Council, Low Voltage Directive (LVD) 2014/35/EU of the European Parliament and of the Council and CE-marking Council Directive 93/68/EEC. This certificate is issued following test carried out on samples of the product referred to above.

The manufacturer hereby warrants normal operation of the unit for 24 months after the retail sale date provided the user's observance of the transportation, storage, installation, and operation regulations. Should any malfunctions occur in the course of the unit operation through the Manufacturer's fault during the guaranteed period of operation, the user is entitled to get all the faults eliminated by the manufacturer by means of warranty repair at the factory free of charge. The warranty repair includes work specific to elimination of faults in the unit operation to ensure its intended use by the user within the guaranteed period of operation. The faults are eliminated by means of replacement or repair of the unit components or a specific part of such unit component.

The warranty repair does not include:

- routine technical maintenance
- unit installation/dismantling
- unit setup

To benefit from warranty repair, the user must provide the unit, the user's manual with the purchase date stamp, and the payment paperwork certifying the purchase. The unit model must comply with the one stated in the user's manual. Contact the Seller for warranty service.

The manufacturer's warranty does not apply to the following cases:

- User's failure to submit the unit with the entire delivery package as stated in the user's manual including submission with missing component parts previously dismantled by the user.
- Mismatch of the unit model and the brand name with the information stated on the unit packaging and in the user's manual.
- User's failure to ensure timely technical maintenance of the unit.
- External damage to the unit casing (excluding external modifications as required for installation) and internal components caused by the user.
- Redesign or engineering changes to the unit.
- Replacement and use of any assemblies, parts and components not approved by the manufacturer.
- Unit misuse.
- Violation of the unit installation regulations by the user.
- Violation of the unit control regulations by the user.
- Unit connection to power mains with a voltage different from the one stated in the user's manual.
- Unit breakdown due to voltage surges in power mains.
- Discretionary repair of the unit by the user.
- Unit repair by any persons without the manufacturer's authorization.
- Expiration of the unit warranty period.
- Violation of the unit transportation regulations by the user.
- Violation of the unit storage regulations by the user.
- Wrongful actions against the unit committed by third parties.
- Unit breakdown due to circumstances of insuperable force (fire, flood, earthquake, war, hostilities of any kind, blockades).
- Missing seals if provided by the user's manual.
- Failure to submit the user's manual with the unit purchase date stamp.
- Missing payment paperwork certifying the unit purchase.



FOLLOWING THE REGULATIONS STIPULATED HEREIN WILL ENSURE A LONG AND TROUBLE-FREE OPERATION OF THE UNIT.



USER'S WARRANTY CLAIMS SHALL BE SUBJECT TO REVIEW ONLY UPON PRESENTATION OF THE UNIT, THE PAYMENT DOCUMENT AND THE USER'S MANUAL WITH THE PURCHASE DATE STAMP.

CERTIFICATE OF ACCEPTANCE

Unit Type	Centrifugal rectangular duct fan
Model	Box _____
Serial Number	
Manufacture Date	
Quality Inspector's Stamp	

SELLER INFORMATION

Seller	
Address	
Phone Number	
E-mail	
Purchase Date	
This is to certify acceptance of the complete unit delivery with the user's manual. The warranty terms are acknowledged and accepted.	
Customer's Signature	

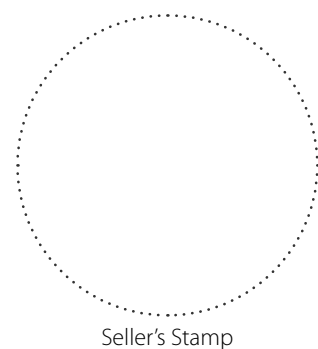

Seller's Stamp

INSTALLATION CERTIFICATE

The Box _____ unit is installed pursuant to the requirements stated in the present user's manual.	
Company name	
Address	
Phone Number	
Installation Technician's Full Name	
Installation Date:	Signature:
The unit has been installed in accordance with the provisions of all the applicable local and national construction, electrical and technical codes and standards. The unit operates normally as intended by the manufacturer.	
Signature:	

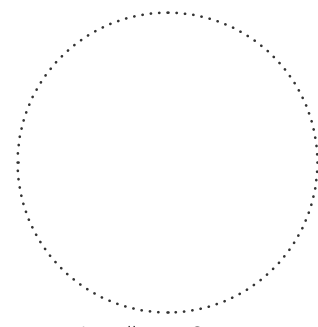

Installation Stamp

WARRANTY CARD

Unit Type	Centrifugal rectangular duct fan
Model	Box _____
Serial Number	
Manufacture Date	
Purchase Date	
Warranty Period	
Seller	

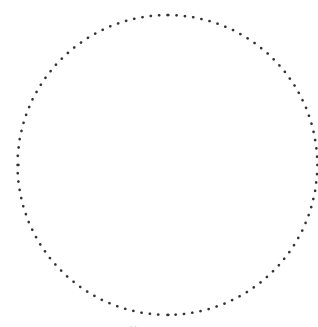

Seller's Stamp



BLAUBERG
Ventilatoren

