

SINGLE-ROOM REVERSIBLE ENERGY RECOVERY VENTILATOR



Vento Eco A50-4 Pro
Vento Eco2 A50-4 Pro

EN

USER'S MANUAL



BLAUBERG
Ventilatoren

CONTENTS

Safety requirements.....	2
Purpose.....	4
Delivery set.....	4
Designation key.....	4
Technical data.....	5
Unit design and operating principle.....	6
Installation and set-up.....	8
Connection to power mains and control.....	11
Technical maintenance.....	15
Troubleshooting.....	16
Storage and transportation regulations.....	16
Manufacturer's warranty.....	17
Certificate of acceptance.....	19
Seller information.....	19
Installation certificate.....	19
Warranty card.....	19

This user's manual is a main operating document intended for technical, maintenance, and operating staff.

The manual contains information about purpose, technical details, operating principle, design, and installation of the Vento Eco(2) A50-4 Pro unit and all its modifications.

Technical and maintenance staff must have theoretical and practical training in the field of ventilation systems and should be able to work in accordance with workplace safety rules as well as construction norms and standards applicable in the territory of the country.

SAFETY REQUIREMENTS

All user's manual requirements as well as the provisions of all the applicable local and national construction, electrical, and technical norms and standards must be observed when installing and operating the unit.

Disconnect the unit from the power supply prior to any connection, servicing, maintenance, and repair operations.

Only qualified electricians with a work permit for electrical units up to 1000 V are allowed for installation. The present user's manual should be carefully read before beginning works.

Check the unit for any visible damage of the impeller, the casing, and the grille before starting installation. The casing internals must be free of any foreign objects that can damage the impeller blades.

While mounting the unit, avoid compression of the casing! Deformation of the casing may result in motor jam and excessive noise.

Misuse of the unit and any unauthorised modifications are not allowed.

Do not expose the device to adverse atmospheric agents (rain, sun, etc.).

Transported air must not contain any dust or other solid impurities, sticky substances, or fibrous materials.

Do not use the unit in a hazardous or explosive environment containing spirits, gasoline, insecticides, etc.

Do not close or block the intake or extract vents in order to ensure the efficient air flow.

Do not sit on the unit and do not put objects on it.

The information in this user's manual was correct at the time of the document's preparation.

The Company reserves the right to modify the technical characteristics, design, or configuration of its products at any time in order to incorporate the latest technological developments.

Never touch the unit with wet or damp hands.

Never touch the unit when barefoot.

This appliance is not intended for use by persons (including children) with reduced physical, sensory or mental capabilities, or lack of experience and knowledge, unless they have been given supervision or instruction concerning use of the appliance by a person responsible for their safety.

Children should be supervised to ensure that they do not play with the appliance.

The connection to the supply mains must be made through a means of disconnection, which is incorporated in the fixed wiring in accordance with the wiring rules, and has a contact separation in all poles that allows for full disconnection under overvoltage category III conditions.

If the supply cord is damaged, it must be replaced by the manufacturer, its service agent, or similarly qualified persons in order to avoid a safety hazard.

Ensure that the appliance is switched off from the supply mains before removing the guard.

Precautions must be taken to avoid the back-flow of gases into the room from the open flue of gas or other fuel-burning appliances.



**THE PRODUCT MUST BE DISPOSED SEPARATELY AT THE END OF ITS SERVICE LIFE.
DO NOT DISPOSE THE UNIT AS UNSORTED DOMESTIC WASTE.**

PURPOSE

The ventilator is designed to ensure continuous mechanical air exchange in flats, cottages, hotels, cafés and other domestic and public premises. It is equipped with a regenerator that enables supply of fresh filtered air heated by means of extract air heat energy recovery.

The ventilator is designed for installation on external walls.

The ventilator is rated for continuous operation.

DELIVERY SET

Name	Quantity	
	Vento Eco A50-4 Pro	Vento Eco2 A50-4 Pro
Air duct	1 pc.	2 pcs.
Sound absorbing material	1 pc.	2 pcs.
Assembled cartridge	1 pc.	2 pcs.
Indoor unit	1 pc.	2 pcs.
Outer ventilation hood	1 pc.	2 pcs.
Control panel	1 pc.	1 pc.
Fastening set	1 packing	1 packing
Mounting box	1 pc.	1 pc.
User's manual	1 pc.	1 pc.
Packing box	1 pc.	1 pc.

DESIGNATION KEY

Vento Eco2 A 50 -4 L S11 Pro

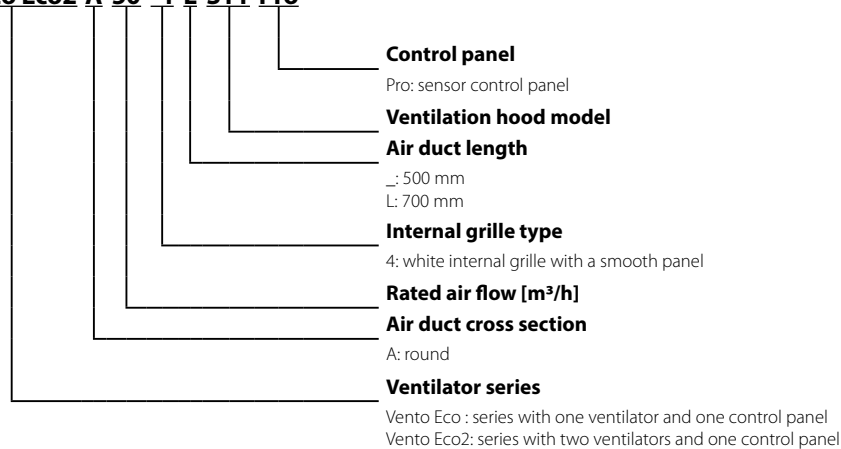

TECHNICAL DATA

The temperature in the room where the indoor unit of the ventilator is installed must be in the range from +1 °C to +40 °C with relative humidity up to 65 % (no condensation build-up). If the conditions for using the ventilator are beyond the specified limits, turn off the ventilator. Provide fresh air supply through windows.

The transported air temperature must be in the range from -20 °C to +40 °C.

The unit is rated as a class II electric appliance.

Ingress protection rating against access to hazardous parts and water ingress is IP24.

The unit design is constantly being improved, thus some models may be slightly different from those described in this manual.

Technical specifications of the particular model are indicated on the unit casing.

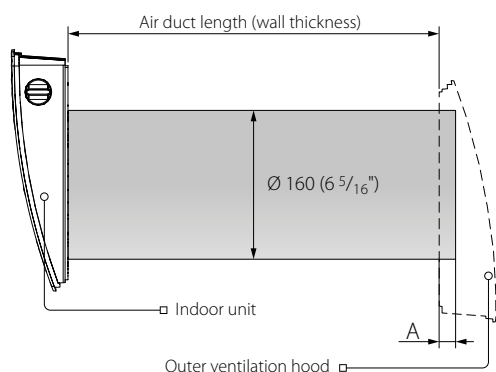

The air duct length depends on the unit model, refer to the Designation Key section, page 4.

Air duct length

Vento Eco A50-4 Pro	250 (150*)-500 (10"(6")-20")
Vento Eco A50-4 Pro L	250 (150*)-700 (10"(6")-28")

*Minimum air duct length with a hood for thin walls EH-2.

The supplied ventilation hood model depends on the ventilator model. The overall dimensions of the outer ventilation hood and the A distance are stated in the installation instruction.

The overall dimensions of the front panel are stated below.

Overall dimensions of the indoor unit [mm]

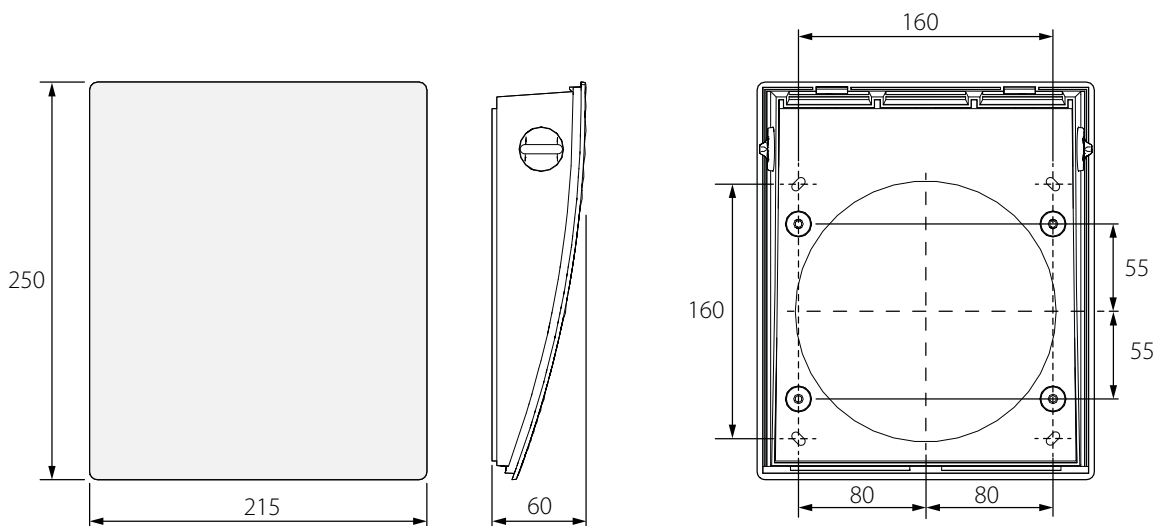

Control panel

The sensor panel contains touch buttons for unit control and an emergency indicator.

Electrical parameters of the control panel	
Supply voltage, 50/60 Hz [V]	100–240
Temperature range [°C] (°F)	from +10 (+50) up to +45 (+113)
Humidity range [%]	10-80 (no condensation)
Service life, number of operating hours	100 000
Ingress protection rating	IP30
Weight [g]	190

Overall dimensions of the control panel [mm]

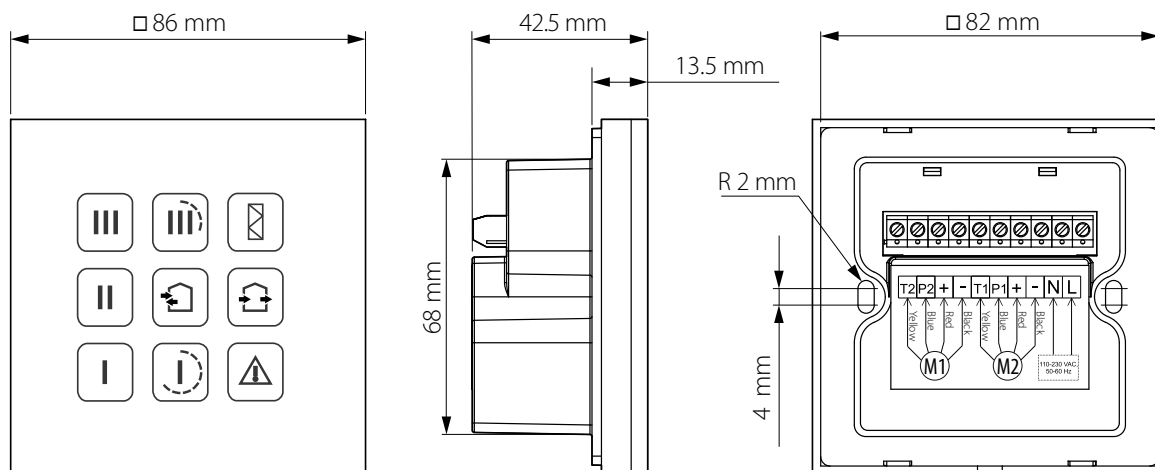

DESIGN AND OPERATING PRINCIPLE

The ventilator consists of an indoor unit with a decorative front panel, a cartridge, an air duct with a sound absorbing layer and an outer ventilation hood.

The cartridge is a basic functioning part of the ventilator. The cartridge consists of a fan, a regenerator and two filters that ensure rough air filtration and prevent ingress of dust and foreign objects into the regenerator and the fan.

The indoor unit is equipped with a manually actuated air damper.

WARNING! Air damper closing does not turn off the ventilator, but only blocks the air flow.

The external protective grille or the ventilation hood on the outer wall prevents ingress of water and foreign objects into the ventilator.

Ventilator design

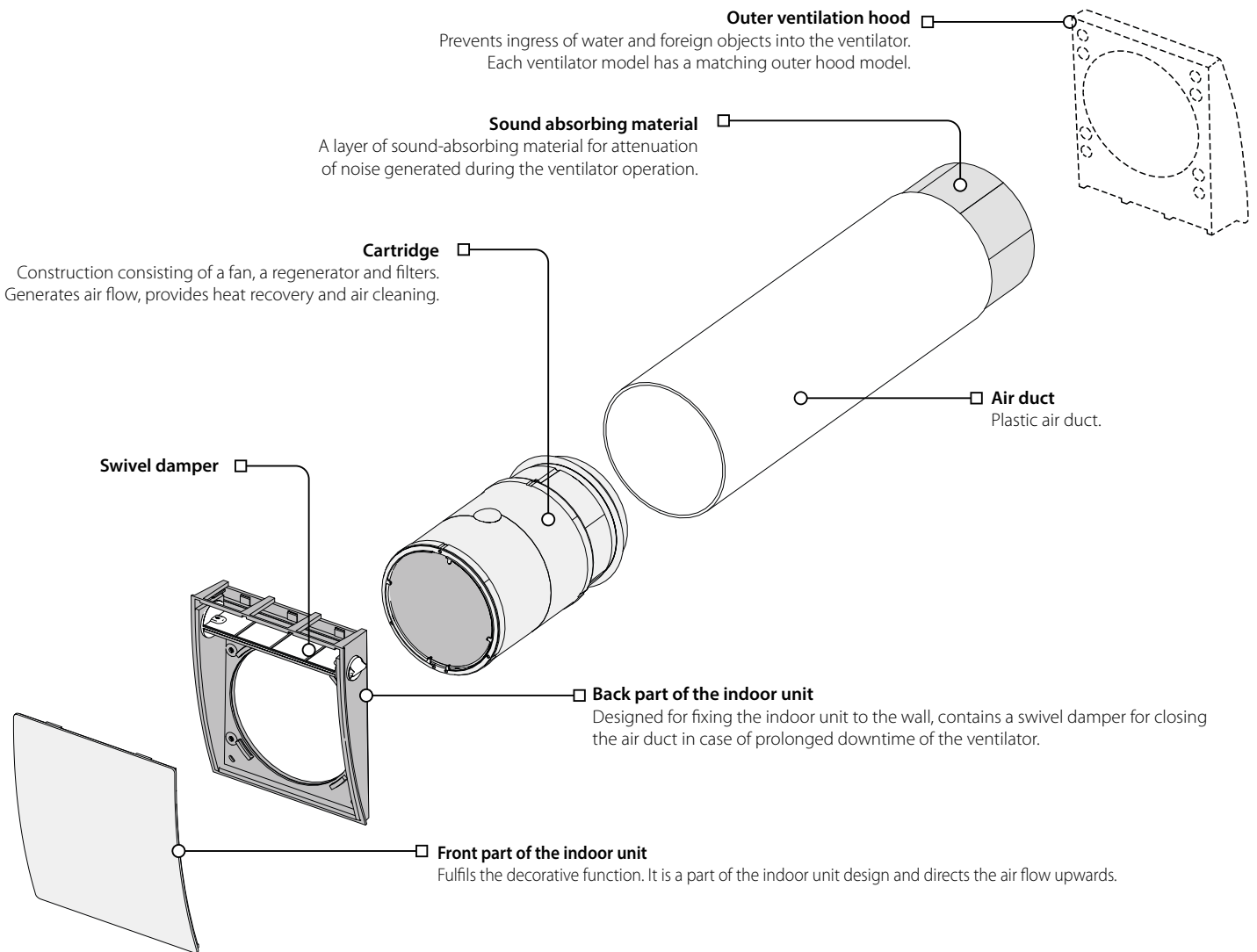

VENTILATOR OPERATION MODES

The ventilator has two operation modes:

Ventilation: the ventilator runs either in extract or supply mode at a set speed.

In this mode, when two ventilators are installed, one of them supplies and the other one extracts the air.

Regeneration: the ventilator runs in two cycles, 70 seconds each, with heat and humidity regeneration.

- **Cycle I.** Warm stale air is extracted from the room and flows through the ceramic regenerator, which gradually absorbs heat and humidity. In 70 seconds, as the ceramic regenerator gets warmed, the ventilator is switched to supply mode.
- **Cycle II.** Fresh intake air from outside flows through the ceramic regenerator, absorbs accumulated moisture and is heated up to the room temperature. In 70 seconds, as the ceramic regenerator gets cooled down, the ventilator is switched to air extract mode and the cycle is renewed. If two ventilators are installed, they operate with opposite rotation directions in this mode. While one ventilator supplies air, the other one extracts it.

MOUNTING AND SET-UP



READ THE USER'S MANUAL BEFORE INSTALLING THE UNIT.

WALL-MOUNTED CONTROL PANEL INSTALLATION



**MAKE SURE THAT THE CONTROL PANEL IS NOT DAMAGED.
DO NOT USE A DAMAGED CONTROL PANEL! DO NOT INSTALL THE CONTROL PANEL ON
AN UNEVEN SURFACE! WHILE TIGHTENING THE SCREWS, DO NOT APPLY EXCESSIVE
FORCE TO PREVENT THE CONTROL PANEL CASING DEFORMATION.**

Control panel mounting:

1. Prepare a hole in the wall and route all the wires to the installation place. Insert the supplied mounting box for flush wall mounting. The mounting box is included in the delivery set.

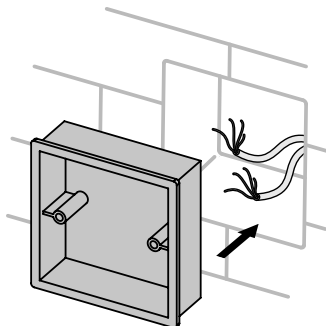

2. Use a screwdriver to carefully undo the clips on the backside of the control panel and remove the back cover.

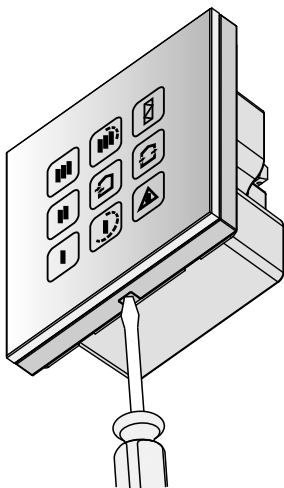

3. Screw the backside of the casing to the mounting box through the fastening holes. Fastening screws for control panel mounting are included in the control panel delivery set. Then connect the cable to the control panel in compliance with external wiring diagram.

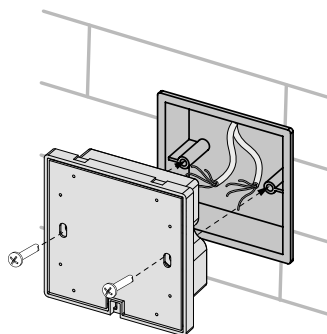

4. Install the control panel display and press it to fix.

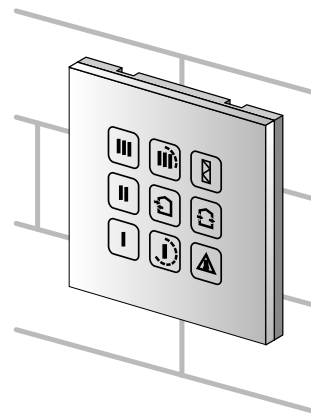

VENTILATOR MOUNTING

 **READ THE USER'S MANUAL BEFORE INSTALLING THE UNIT.**

 **DO NOT BLOCK THE AIR DUCT OF THE INSTALLED UNIT WITH DUST ACCUMULATING MATERIALS, SUCH AS CURTAINS, CLOTH SHUTTERS, ETC. AS IT PREVENTS AIR CIRCULATION IN THE ROOM.**

1. Prepare holes for the air ducts.

Prepare one or two round core holes in the outer wall, depending on the ventilation system equipment. For efficient operation of the ventilation system it is recommended to install the ventilators as far apart from one another as possible. While preparing a core hole make preparations for layout of the power cable and other required cables. The core hole size and minimum distance to a mounting surface, for example, a wall, ceiling or a window as well as the minimum distance between the ventilators are shown below.

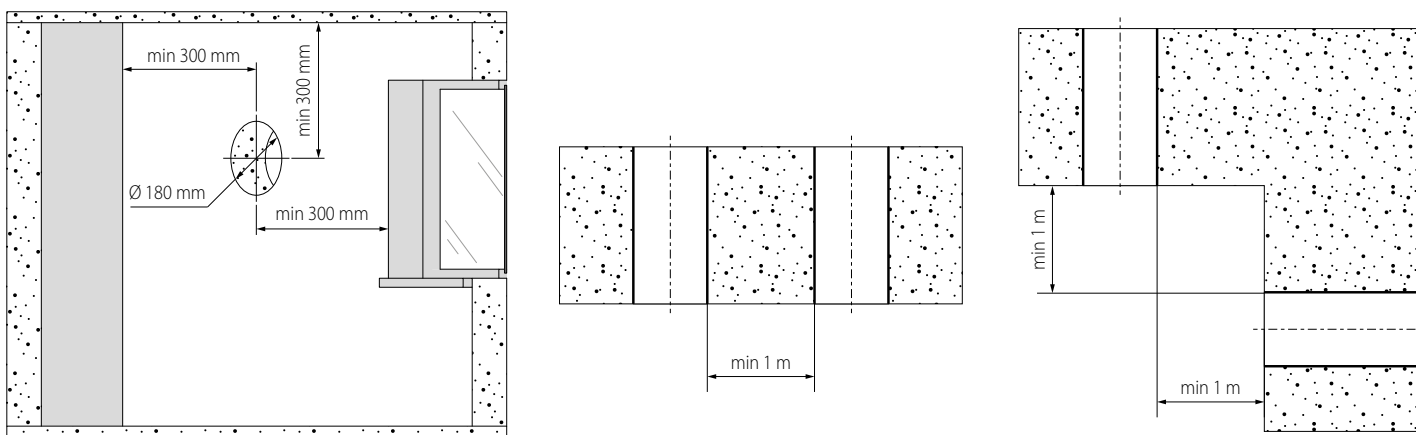

2. Prepare air ducts of required length.

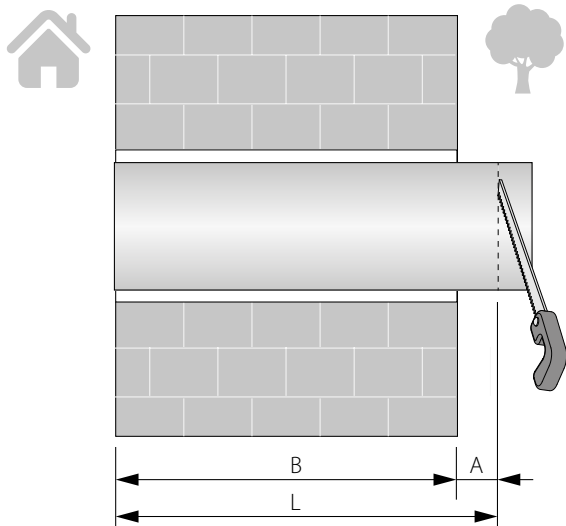

Measure the wall thickness B.

The air duct length is calculated as $L = B + A$, where A means an air duct segment that protrudes in the outer wall to enable installation of the external grille or the outer ventilation hood.

Distance A is stated in the installation instruction for the ventilation hood.

Cut the air duct to the length L

3. Insert the sound-absorbing layer in the air duct.

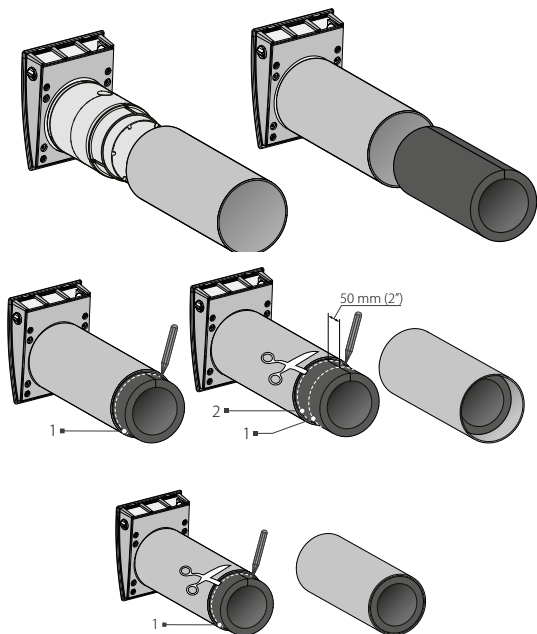

Prior to installation adjust its length with respect to the dimensions of the cartridge, the indoor unit, and the outer hood.

Insert the cartridge during adjustment in the air duct and cover it with the internal grille. Roll the sound-absorbing layer to match the air duct diameter with the protecting paper layer outside and insert the roll in the air duct against stop.

Do not remove the paper layer!

Ventilator with an internal grille

Mark the sound-absorbing layer at the end of the air duct as 1. From the mark 1 measure 50 mm (2") and make the mark 2. Cut the excessive part of the sound-absorbing layer.

Insert the adjusted and ready sound-absorbing layer into the air duct. No glue is required for fixation!

Ventilator with an outer hood (option).

Mark the sound-absorbing layer at the end of the air duct as 1. Cut the excessive part of the sound-absorbing layer.

Insert the adjusted and ready sound-absorbing layer into the air duct. No glue is required for fixation!

4. Insert the air duct in the wall.

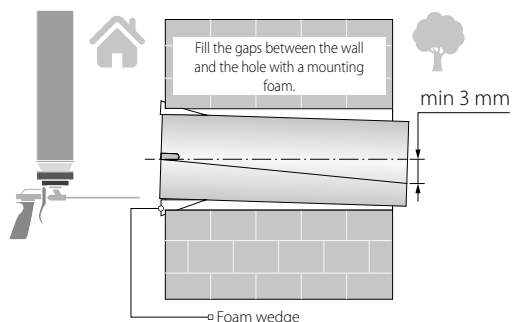

Install the air duct with the minimum slope 3 mm downwards. Fill the gaps between the wall and the hole with a mounting foam.

5. Secure the back part of the indoor unit by leading the cable through the hole. Insert the cartridge into the air duct. Disconnect the connector on the cartridge wire and connect the wires (laid from the control panel in accordance with the diagram on page 12) to the mating part. Connect the parts of the terminal block.

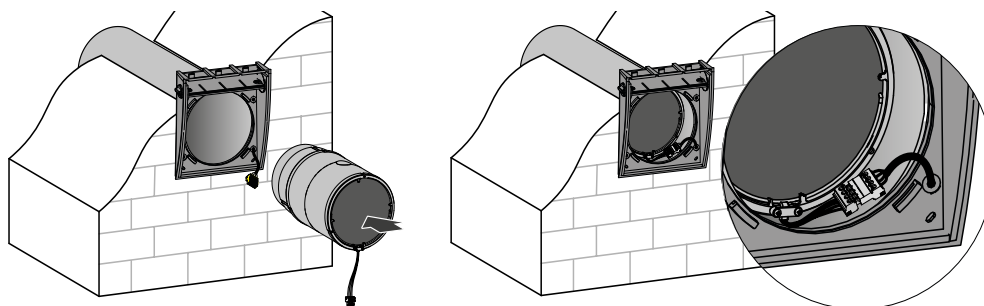

6. Install the front panel of the indoor unit and fasten the outer ventilation hood.

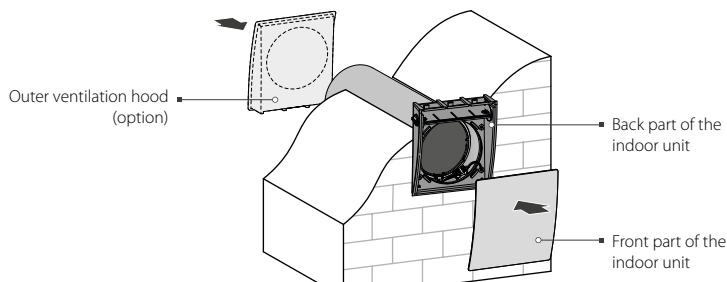

For mounting of the outer ventilation hood, please refer to a respective hood installation instruction.

CONNECTION TO POWER MAINS



**POWER OFF THE POWER SUPPLY PRIOR TO ANY OPERATIONS WITH THE UNIT.
THE UNIT MUST BE CONNECTED TO POWER SUPPLY BY A QUALIFIED ELECTRICIAN.
THE RATED ELECTRICAL PARAMETERS OF THE UNIT ARE GIVEN ON THE
MANUFACTURER'S LABEL.**



**ANY TAMPERING WITH THE INTERNAL CONNECTIONS IS PROHIBITED
AND WILL VOID THE WARRANTY.**

The ventilator is rated for connection to single-phase AC 100-240 V 50/60 Hz power mains.

The ventilator is connected to power mains using insulated, durable and heat-resistant conductors (cables, wires) with a cross section of at least 0.5-0.75 mm² through the automatic circuit breaker with a magnetic trip built into the stationary wiring. The circuit breaker trip current must be selected depending on the ventilator current consumption. For details, please refer to the table on page 5. The actual conductor cross-section selection must be based on its type, maximum permissible heating, insulation, length and installation method.

When choosing a signal cable, follow these guidelines:

- Always use a shielded cable.
- The cross-section of the conductors, depending on the length, is selected according to the table below.

Cable length [m]	The minimum cross-section of the wires in the cable [mm ²]
< 5	0.25
< 10	0.5
< 15	0.75
< 30	1.5

- Lay a signal cable in compliance with the requirements of the relevant regulatory documents.
- Connect the signal cable shield to the terminals „-“ of the control panel and the fan. Use copper wires for all the electric connections!
- Connect the ventilator to power mains in compliance with the wiring diagram.

EXTERNAL CONNECTIONS WIRING DIAGRAM OF THE VENTILATOR WITH A CONTROL PANEL

Each unit is connected as an air supply unit

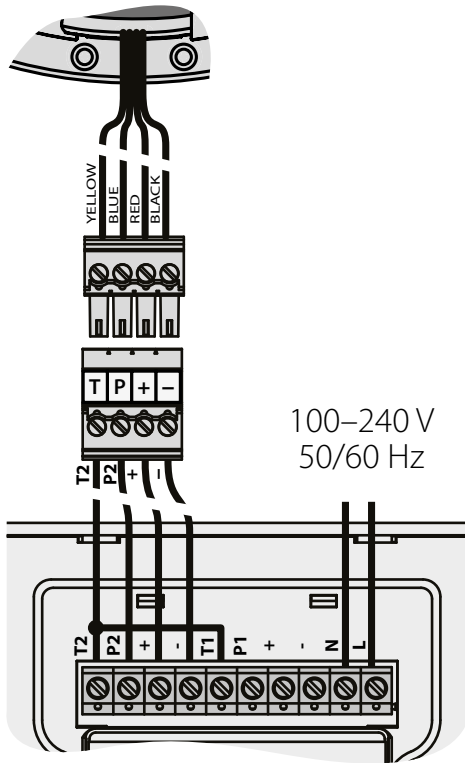

Each unit is connected as an air exhaust unit

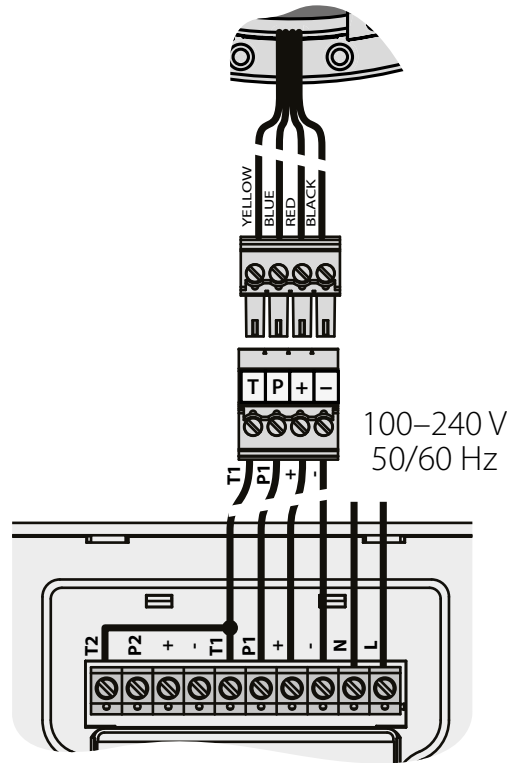

Two units are connected to the control panel

supply

extract

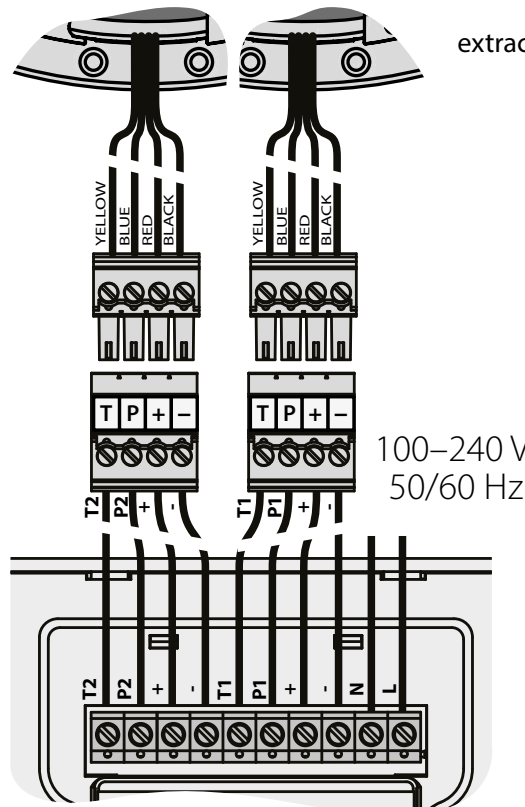

VENTILATOR CONTROL

The ventilator is operated with a control panel.

WARNING!

- The control panel must be fixed on a surface in operational position!
- Do not switch the buttons on the unsecured panel to avoid false speed switching!
- Pressing the buttons quickly and shortly may result in malfunction of the unit!
- Press the button precisely in the desired sector of the control panel to switch the speed.

The following parameters are set with the control panel:

- Ventilator speed stage: I, II, III;
- Operation mode: Regeneration or Ventilation;
- Timer-based operation of the ventilator: 4 hours at speed III or 8 hours at speed I.

The control panel displays the following parameters:

- current ventilator speed;
- current operation mode of the ventilator;
- timer operation status (on/off)
- filter replacement/cleaning need according to indications of the filter timer (factory setting 90 days)
- emergency shutdown of the ventilator in case of a motor failure.

In case of power cut-off, the set parameters are saved in the non-volatile memory of the control panel.

DESCRIPTION OF FUNCTIONS OF THE CONTROL PANEL BUTTONS

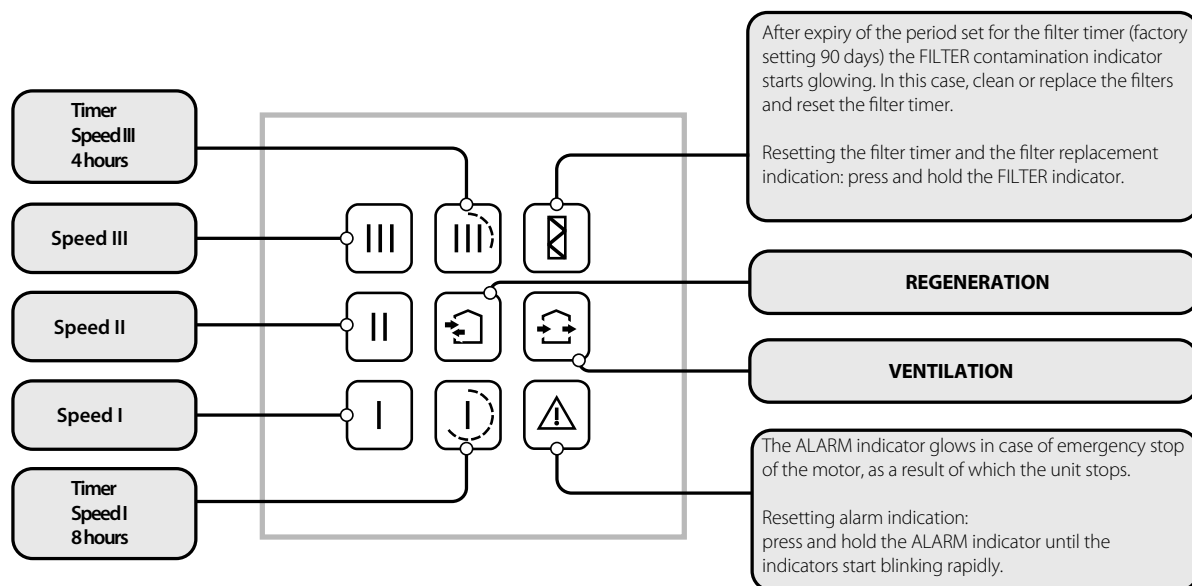

Turning the unit on	Press any of speed selection buttons , , or the timer buttons , .
Turning the unit off	Press the active speed button , , or the active timer button , , if no speed button is active.
Unit speed selection	Press the inactive speed button , , .
Unit operation mode selection	Press the inactive REGENERATION or VENTILATION button. The direction of air flow in the unit (supply and extract mode) is set when connecting the unit according to the external connections wiring diagram.
Turning the timer on	Press the TIMER button or .
Timer selection	Press the inactive TIMER button or .
Turning the timer off	Press the active TIMER button or .
	If the timer period expires: <ul style="list-style-type: none"> • The unit continues operation at a set speed. The speed can be selected before switching on the timer as well as during the timer-based operation. • The unit turns off if the speed was not selected.

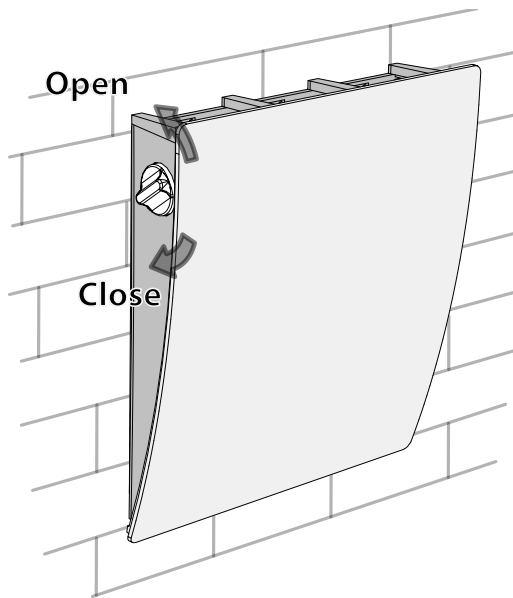

AIR DUCT CLOSING

The indoor unit has a swivel damper. To open or close the air duct, turn one of the handles on the side walls of the indoor unit until it stops, as shown in the figure. The vertical position of the handle corresponds to the position OPEN, the horizontal position - to the position CLOSED.

WARNING! Air damper opening or closing does not turn the ventilator on or off!

TECHNICAL MAINTENANCE





DISCONNECT THE UNIT FROM POWER SUPPLY BEFORE ANY MAINTENANCE OPERATIONS!

Maintenance of the ventilator means regular cleaning of the ventilator surfaces of dust and cleaning or replacement of the filters. To access the basic assembly units follow the steps:

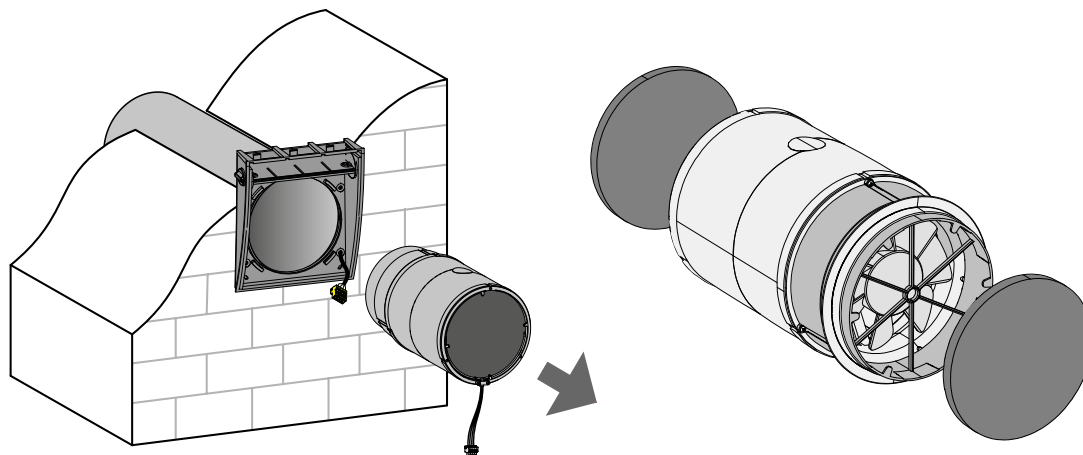
Remove the front part of the indoor unit, disconnect the connector and remove the cartridge from the air duct by pulling the cord. Remove the filters from the cartridge.



Clean the filters as they get clogged, but not less than once in three months.

- After expiry of the period set for the hour meter (factory setting 90 days) the filter replacement indicator  appears on the control panel display.
- Wash the filters and let those dry out completely. Then install the dry filters in the air duct.
- Vacuum cleaning is allowed.
- To reset the filter timer, press and hold the button  for 4-5 seconds.
- The filter rated service life is 3 years.
- For new filters contact the Seller.

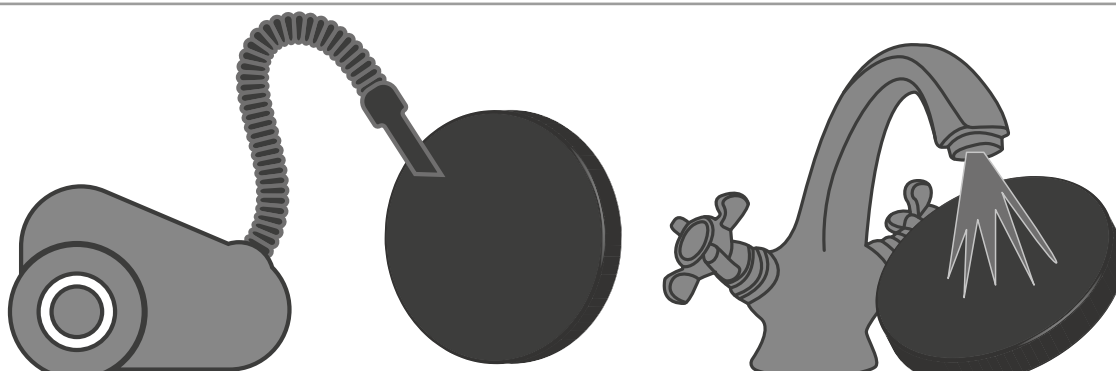

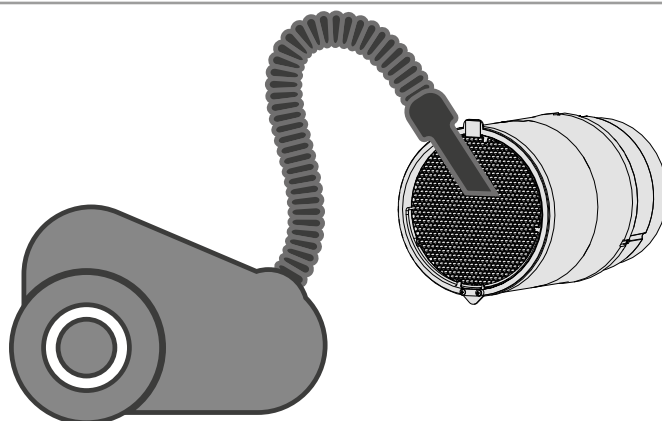

Even regular technical maintenance may not completely prevent dirt accumulation on the regenerator and the fan.

- Clean the regenerator regularly to ensure its high heat recovery efficiency.
- Vacuum clean the regenerator not less than once a year.



TROUBLESHOOTING

Possible faults and troubleshooting

Problem	Possible reasons	Troubleshooting
The fan does not start up during the ventilator start-up. The control panel displays no information and does not respond to the button pressing.	No power supply.	Contact a qualified electrician to check mains connection and eliminate a connection error if there is one.
The control panel displays an alarm indicator  .	The motor is jammed, the impeller blades are clogged.	Turn the ventilator off. Clean the impeller to troubleshoot the motor jam. Restart the ventilator.
	Communication loss in connecting cable between the fan motor and the control panel.	Turn the ventilator off. Contact the Seller for further information.
The control panel displays filter replacement indicator  .	The filter usage time has elapsed.	Description of the filter cleaning procedure, see page 15.
Circuit breaker tripping during the ventilation unit start-up.	Overcurrent as a result of short circuit in the electric line.	Turn the ventilator off. Contact the Seller for further information.
Low air flow.	Low set fan speed.	Set higher speed.
	The filters, the fan or the regenerator are clogged.	Clean or replace the filter. Clean the fan and the heat exchanger.
Noise, vibration.	The impeller is clogged.	Clean the impeller.

STORAGE AND TRANSPORTATION REGULATIONS

- Store the unit in the manufacturer's original packaging box in a dry closed ventilated premise with temperature range from +5 °C (+41 °F) to + 40 °C (+104 °F) and relative humidity up to 70 %.
- Storage environment must not contain aggressive vapors and chemical mixtures provoking corrosion, insulation, and sealing deformation.
- Use suitable hoist machinery for handling and storage operations to prevent possible damage to the unit.
- Follow the handling requirements applicable for the particular type of cargo.
- The unit can be carried in the original packaging by any mode of transport provided proper protection against precipitation and mechanical damage. The unit must be transported only in the working position.
- Avoid sharp blows, scratches, or rough handling during loading and unloading.
- Prior to the initial power-up after transportation at low temperatures, allow the unit to warm up at operating temperature for at least 3-4 hours.

MANUFACTURER'S WARRANTY

The product is in compliance with EU norms and standards on low voltage guidelines and electromagnetic compatibility. We hereby declare that the product complies with the provisions of Electromagnetic Compatibility (EMC) Directive 2014/30/EU of the European Parliament and of the Council, Low Voltage Directive (LVD) 2014/35/EU of the European Parliament and of the Council and CE-marking Council Directive 93/68/EEC. This certificate is issued following test carried out on samples of the product referred to above.

The manufacturer hereby warrants normal operation of the unit for 24 months after the retail sale date provided the user's observance of the transportation, storage, installation, and operation regulations. Should any malfunctions occur in the course of the unit operation through the Manufacturer's fault during the guaranteed period of operation, the user is entitled to get all the faults eliminated by the manufacturer by means of warranty repair at the factory free of charge. The warranty repair includes work specific to elimination of faults in the unit operation to ensure its intended use by the user within the guaranteed period of operation. The faults are eliminated by means of replacement or repair of the unit components or a specific part of such unit component.

The warranty repair does not include:

- routine technical maintenance
- unit installation/dismantling
- unit setup

To benefit from warranty repair, the user must provide the unit, the user's manual with the purchase date stamp, and the payment paperwork certifying the purchase. The unit model must comply with the one stated in the user's manual. Contact the Seller for warranty service.

The manufacturer's warranty does not apply to the following cases:

- User's failure to submit the unit with the entire delivery package as stated in the user's manual including submission with missing component parts previously dismantled by the user.
- Mismatch of the unit model and the brand name with the information stated on the unit packaging and in the user's manual.
- User's failure to ensure timely technical maintenance of the unit.
- External damage to the unit casing (excluding external modifications as required for installation) and internal components caused by the user.
- Redesign or engineering changes to the unit.
- Replacement and use of any assemblies, parts and components not approved by the manufacturer.
- Unit misuse.
- Violation of the unit installation regulations by the user.
- Violation of the unit control regulations by the user.
- Unit connection to power mains with a voltage different from the one stated in the user's manual.
- Unit breakdown due to voltage surges in power mains.
- Discretionary repair of the unit by the user.
- Unit repair by any persons without the manufacturer's authorization.
- Expiration of the unit warranty period.
- Violation of the unit transportation regulations by the user.
- Violation of the unit storage regulations by the user.
- Wrongful actions against the unit committed by third parties.
- Unit breakdown due to circumstances of insuperable force (fire, flood, earthquake, war, hostilities of any kind, blockades).
- Missing seals if provided by the user's manual.
- Failure to submit the user's manual with the unit purchase date stamp.
- Missing payment paperwork certifying the unit purchase.



FOLLOWING THE REGULATIONS STIPULATED HEREIN WILL ENSURE A LONG AND TROUBLE-FREE OPERATION OF THE UNIT.



USER'S WARRANTY CLAIMS SHALL BE SUBJECT TO REVIEW ONLY UPON PRESENTATION OF THE UNIT, THE PAYMENT DOCUMENT AND THE USER'S MANUAL WITH THE PURCHASE DATE STAMP.

CERTIFICATE OF ACCEPTANCE

Unit Type	Single-room reversible energy recovery ventilator
Model	Vento Eco _____
Serial Number	
Manufacture Date	
Quality Inspector's Stamp	

SELLER INFORMATION

Seller	
Address	
Phone Number	
E-mail	
Purchase Date	
This is to certify acceptance of the complete unit delivery with the user's manual. The warranty terms are acknowledged and accepted.	
Customer's Signature	

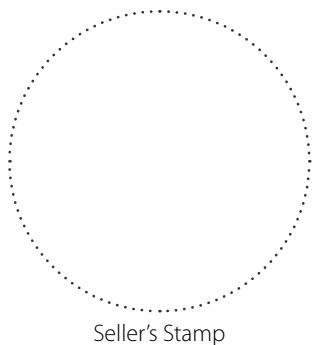

Seller's Stamp

INSTALLATION CERTIFICATE

The Vento Eco _____ unit is installed pursuant to the requirements stated in the present user's manual.	
Company name	
Address	
Phone Number	
Installation Technician's Full Name	
Installation Date:	Signature:
The unit has been installed in accordance with the provisions of all the applicable local and national construction, electrical and technical codes and standards. The unit operates normally as intended by the manufacturer.	
Signature:	

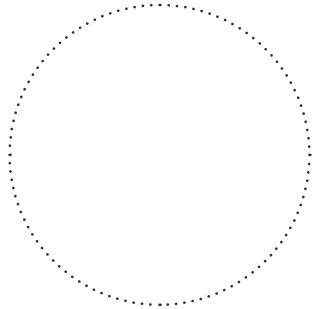

Installation Stamp

WARRANTY CARD

Unit Type	Single-room reversible energy recovery ventilator
Model	Vento Eco _____
Serial Number	
Manufacture Date	
Purchase Date	
Warranty Period	
Seller	

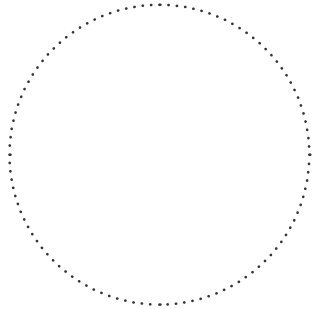

Seller's Stamp



BLAUBERG
Ventilatoren

