

## **SINGLE-ROOM HEAT RECOVERY AIR HANDLING UNIT**



*CIVIC EC LB 300 V.2*  
*CIVIC EC LBE 300 V.2*  
*CIVIC EC LBE2 300 V.2*  
*CIVIC EC LB 300-E V.2*  
*CIVIC EC LBE 300-E V.2*  
*CIVIC EC LBE2 300-E V.2*

*CIVIC EC LB 500 V.2*  
*CIVIC EC LBE 500 V.2*  
*CIVIC EC LBE2 500 V.2*

**EN**

**USER'S MANUAL**

## CONTENTS

Safety requirements.....	2
Purpose.....	4
Delivery set.....	4
Designation key.....	4
Technical data.....	5
Design and operating principle.....	6
Mounting and set-up.....	8
Connection to power mains.....	11
Technical maintenance.....	13
Troubleshooting.....	15
Storage and transportation regulations.....	15
Manufacturer's warranty.....	16
Certificate of acceptance.....	17
Seller information.....	17
Installation certificate.....	17
Warranty card.....	17

This user's manual is a main operating document intended for technical, maintenance, and operating staff.

The manual contains information about purpose, technical details, operating principle, design, and installation of the CIVIC EC LB(E, E2) 300/500(-E) V.2 unit and all its modifications.

Technical and maintenance staff must have theoretical and practical training in the field of ventilation systems and should be able to work in accordance with workplace safety rules as well as construction norms and standards applicable in the territory of the country.

## SAFETY REQUIREMENTS

This unit is not intended for use by persons (including children) with reduced physical, sensory or mental capabilities, or lack of experience and knowledge, unless they have been given supervision or instruction concerning use of the unit by a person responsible for their safety. Children should be supervised to ensure that they do not play with the unit.

This appliance can be used by children aged from 8 years and above and persons with reduced physical, sensory or mental capabilities or lack of experience and knowledge if they have been given supervision or instruction concerning use of the appliance in a safe way and understand the hazards involved.

Cleaning and user maintenance shall not be made by children without supervision.

Children shall not play with the appliance.

Ensure that the unit is switched off from the supply mains before removing the guard.

Precautions must be taken to avoid the back-flow of gases into the room from the open flue of gas or other fuel-burning appliances.

The appliance may adversely affect the safe operation of appliances burning gas or other fuels (including those in other rooms) due to back flow of combustion gases. These gases can potentially result in carbon monoxide poisoning. After installation of the unit the operation of flued gas appliances should be tested by a competent person to ensure that back flow of combustion gases does not occur.

Do not attach the product to the support using glue or adhesives. Use only the fastening method specified in the «User's manual».

Connection to the mains must be made through a disconnecting device, which is integrated into the fixed wiring system in accordance with the wiring rules for design of electrical units, and has a contact separation in all poles that allows for full disconnection under overvoltage category III conditions.

All operations described in this manual must be performed by qualified personnel only, properly trained and qualified to install, make electrical connections and maintain ventilation units.

Do not attempt to install the product, connect it to the mains, or perform maintenance yourself. This is unsafe and impossible without special knowledge.

Disconnect the power supply prior to any operations with the unit.

All user's manual requirements as well as the provisions of all the applicable local and national construction, electrical, and technical norms and standards must be observed when installing and operating the unit.

Disconnect the unit from the power supply prior to any connection, servicing, maintenance, and repair operations.

Connection of the unit to power mains is allowed by a qualified electrician with a work permit for the electric units up to 1000 V after careful reading of the present user's manual.

Check the unit for any visible damage of the impeller, the casing, and the grille before starting installation. The casing internals must be free of any foreign objects that can damage the impeller blades.

While mounting the unit, avoid compression of the casing! Deformation of the casing may result in motor jam and excessive noise.

Misuse of the unit and any unauthorised modifications are not allowed.

Do not expose the unit to adverse atmospheric agents (rain, sun, etc.).

Transported air must not contain any dust or other solid impurities, sticky substances, or fibrous materials.

Do not use the unit in a hazardous or explosive environment containing spirits, gasoline, insecticides, etc.

Do not close or block the intake or extract vents in order to ensure the efficient air flow.

Do not sit on the unit and do not put objects on it.

The information in this user's manual was correct at the time of the document's preparation.

The Company reserves the right to modify the technical characteristics, design, or configuration of its products at any time in order to incorporate the latest technological developments.

Never touch the unit with wet or damp hands.

Never touch the unit when barefoot.

BEFORE INSTALLING ADDITIONAL EXTERNAL DEVICES, READ THE RELEVANT USER MANUALS.



**THE PRODUCT MUST BE DISPOSED SEPARATELY AT THE END OF ITS SERVICE LIFE.  
DO NOT DISPOSE THE UNIT AS UNSORTED DOMESTIC WASTE.**

**PURPOSE**

The unit is designed to ensure continuous mechanical air exchange in houses, offices, hotels, cafes, conference halls, and other utility and public spaces as well as to recover the heat energy contained in the air extracted from the premises to warm up the filtered stream of intake air.

The unit is not intended for organizing ventilation in swimming pools, saunas, greenhouses, summer gardens, and other spaces with high humidity.

Due to the ability to save heating energy by means of energy recovery, the unit is an important element of energy-efficient premises.

The unit is a component part and is not designed for stand-alone operation. It is rated for continuous operation.

Transported air must not contain any flammable or explosive mixtures, evaporation of chemicals, sticky substances, fibrous materials, coarse dust, soot and oil particles or environments favourable for the formation of hazardous substances (toxic substances, dust, pathogenic germs).

**DELIVERY SET**

NAME	NUMBER
Air handling unit	1
User's manual	1
Key to a service panel	1
Packing box	1

**DESIGNATION KEY**

Example of designation: **CIVIC EC LBE CP 300-E V.2 S21-1**

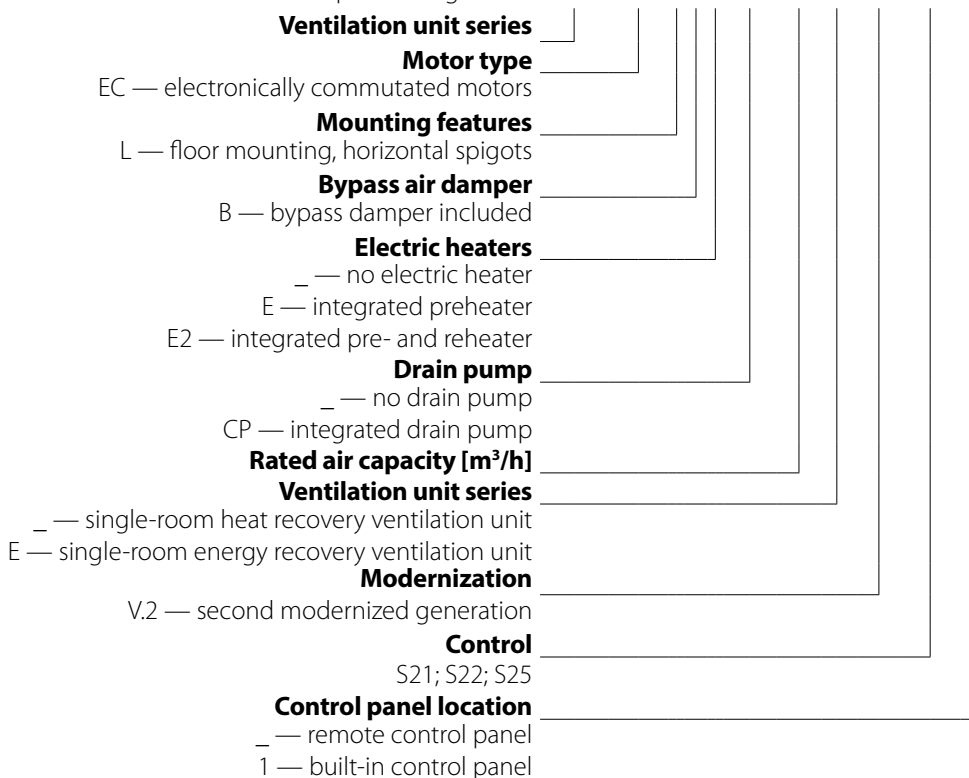

## TECHNICAL DATA

The unit is designed for indoor application with the ambient temperature ranging from +1 °C up to +40 °C and relative humidity up to 60 % without condensation. In cold, damp rooms, there is a possibility of freezing or condensation inside and outside the casing.

In order to prevent condensation on the internal walls of the unit, it is necessary that the surface temperature of the casing is 2-3 °C above the dew point temperature of the transported air.

The unit should be operated continuously, and in cases where ventilation is not necessary, reduce the air flow of the fans to a minimum (20%). This will ensure a favorable indoor climate and reduce the amount of condensation inside the unit, which can damage electronic components. Never use the unit for dehumidification, for example, of new buildings.

The unit is rated as a Class I electrical appliance.

Hazardous parts access and water ingress protection rating:

IP20 for the unit connected to the air ducts.

IP44 for the unit motors.

The unit design is constantly being improved, thus some models may be slightly different from those described in this manual.

Model	Civic 300 LB EC V.2	Civic 300 LBE EC V.2	Civic 300 LBE2 EC V.2	Civic 300 LB EC V.2	Civic 300 LBE EC V.2	Civic 300 LBE2 EC V.2	Civic 500 LB EC V.2	Civic 500 LBE EC V.2	Civic 500 LBE2 EC V.2
Power supply voltage [V/50(60*) Hz]	1~230								
Unit power consumption excl. electric heater [W]	92						240		
Preheater power consumption [W]	-	1050	1050	-	1050	1050	-	1050	1050
Reheater power consumption [W]	-	-	700	-	-	700	-	-	700
Maximum unit current excl. electric heater [A]	0,7						1,2		
Maximum unit current incl. electric heater(s) [A]	-	7	11	-	7	11	-	7,8	12
Maximum air flow [m <sup>3</sup> /h]	320						580		
Noise level, 1 m [dBA]	37						44		
Noise level, 3 m [dBA]	47						34		
Transported air temperature [°C]	-25...+40								
Casing material	painted steel								
Insulation	40 mm mineral wool								
Extract filter	ISO Coarse >60% (G4)								
Supply filter	ISO ePM1 60% (F7)								
Connected duct diameter [mm]	200			200			250		
Weight [kg]	138±3%	139±3%	140±3%	136±3%	137±3%	138±3%	139,3	140,8	142,5
Heat recovery efficiency [%]	78-92			73-89			75-94		
Heat exchanger type	counter-flow								
Heat exchanger material	polystyrene			enthalpy			polystyrene		

**Units without a drain pump are designed to operate in an electrical supply network with a frequency of 50(60) Hz, with a drain pump — 50 Hz only.**

**UNIT OVERALL DIMENSIONS [mm]**

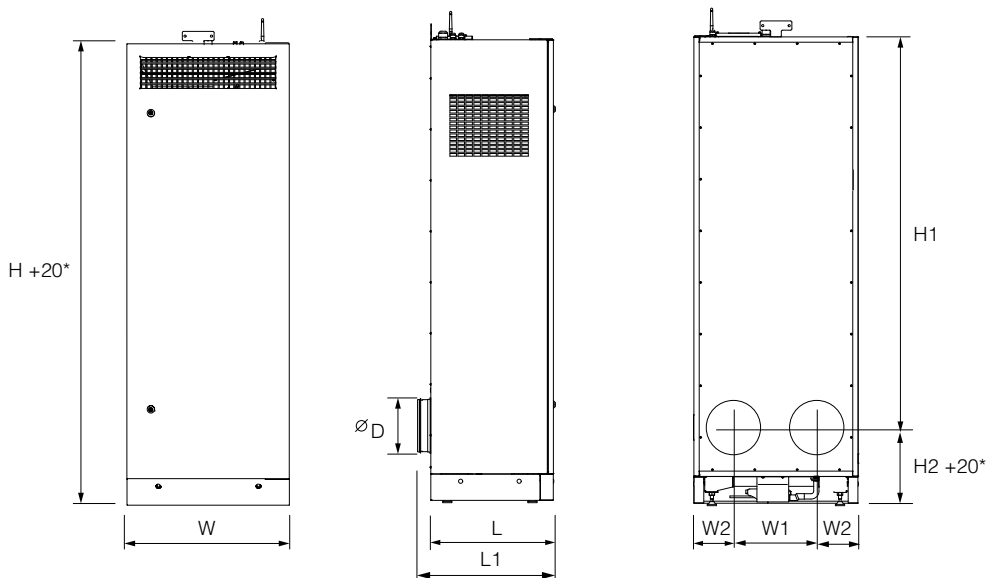

Model	D	W	W1	W2	L	L1	H	H1	H2
Civic 300 LB EC V.2 Civic 300 LBE EC V.2 Civic 300 LBE2 EC V.2	200	620	310	155	470	520	1775	1485	285
Civic 300 LB EC V.2 Civic 300 LBE EC V.2 Civic 300 LBE2 EC V.2									
Civic 500 LB EC V.2 Civic 500 LBE EC V.2 Civic 500 LBE2 EC V.2	250	750	350	200	535	585	2170	1865	305

\* The unit height may be adjusted by means of levelling feet.

**DESIGN AND OPERATING PRINCIPLE**

The unit operation is as follows:

Warm extract air from the room flows into the unit and is cleaned in the extract filters. Then the air is moved through the heat exchanger and is exhausted outside through the air ducts with the exhaust fan. Cold fresh air from outside flows into the unit, where it is cleaned with the supply filters. Then the air flows through the heat exchanger and is moved to the room with the supply fan. Supply air is heated in the heat exchanger by transferring the heat energy of warm and humid extract air to the cold fresh air. The air flows are fully separated while flowing through the heat exchanger. Heat recovery minimizes heat losses, which reduces the cost of space heating in the cold season.

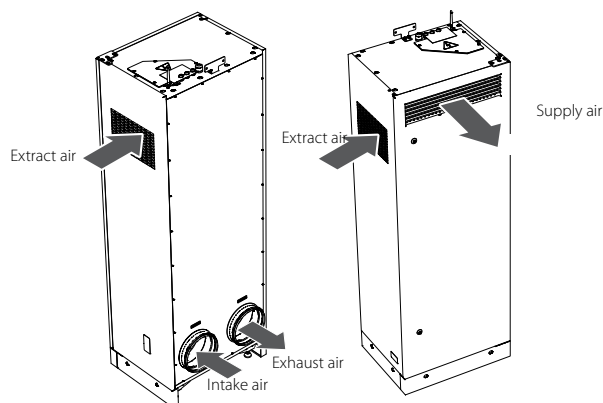

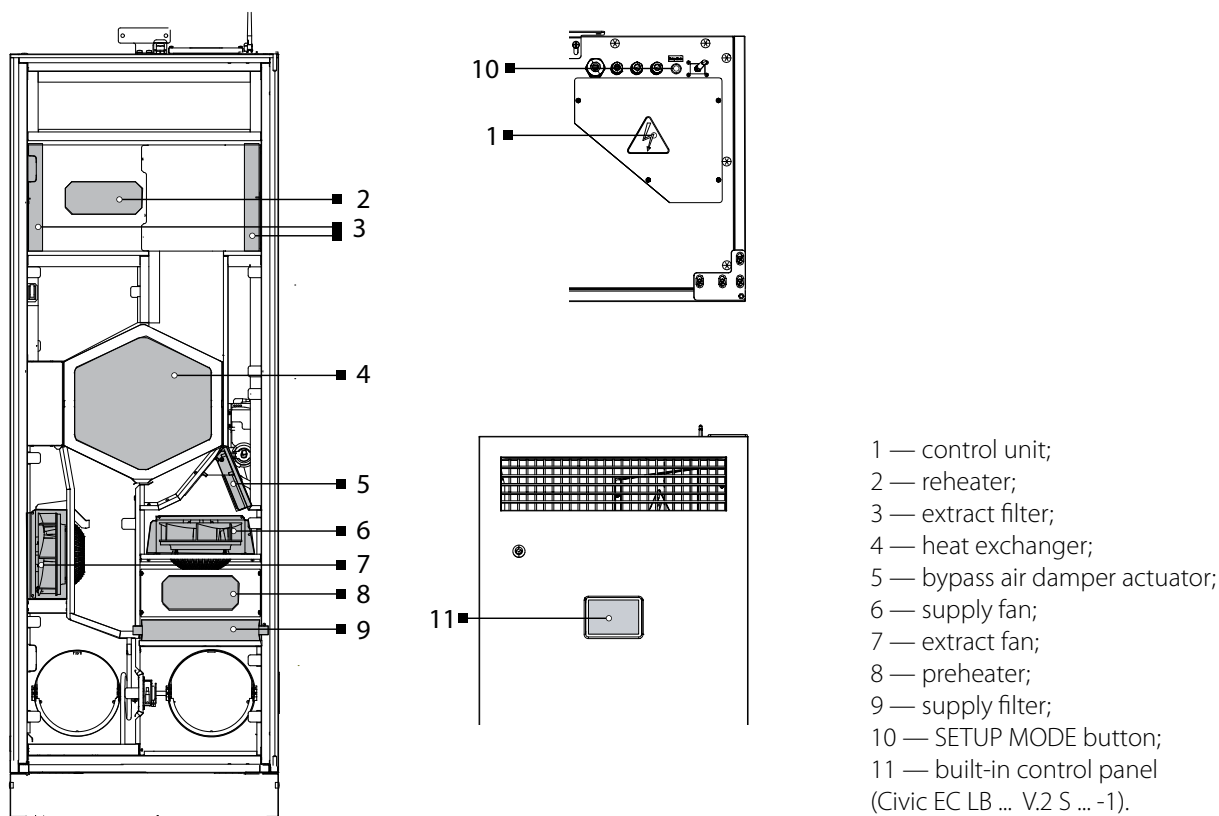

- 1 — control unit;
- 2 — reheater;
- 3 — extract filter;
- 4 — heat exchanger;
- 5 — bypass air damper actuator;
- 6 — supply fan;
- 7 — extract fan;
- 8 — preheater;
- 9 — supply filter;
- 10 — SETUP MODE button;
- 11 — built-in control panel  
(Civic EC LB ... V.2 S ... -1).

The unit is a frame structure made of rigidly fixed steel panels.

The panels are made of painted steel sheets and a galvanized steel sheet with a layer of mineral wool between for heat- and sound-insulation. The service door enables access for maintenance and service operations.

The unit design enables installation of a bypass duct with a bypass damper to route the intake air stream without contacting the heat exchanger.

The unit has three automatic heat exchanger freeze protection modes, depending on the unit model.

**Units without heater:** the supply fan turns off in case of a freezing danger\*.

**Units with a reheater (with preheater disabled):** the bypass system is activated in case of a freezing danger\*.

**Units with a preheater:** the pre-heating is turned on in case of a freezing danger\*.

\* danger of freezing appears when the exhaust air temperature downstream of the heat exchanger is lower than +5 °C and intake air temperature upstream of the heat exchanger is lower than -3 °C.

The supply and extract air temperature difference during heat recovery may lead to condensate formation in the units with a polystyrene heat exchanger. The condensate collects in the drain pan and removes outside.

#### **Additional equipment (is not included in the delivery set, can be ordered separately)**

**Humidity sensor.** The unit with the installed humidity sensor maintains a set indoor humidity point.

As the extract air humidity rises above the set point, the system automatically switches to the maximum speed. As the humidity drops down below the set point the unit returns to the previous mode.

**CO<sub>2</sub> sensor.** Measures the level of concentration of carbon dioxide in the room and generates a signal that controls the performance of the fan. Air capacity control based on CO<sub>2</sub> concentration is an efficient energy saving solution.

**VOC sensor.** Qualitative assessment of air saturation with contaminants (cigarette smoke, exhaled air, solvent and detergent vapours). The sensor sensitivity can be adjusted with regards to the expected maximum level of air pollution.

Enables on-demand ventilation which results in considerable energy savings as air is exchanged only upon reaching the preset level of pollution.

**MOUNTING AND SET-UP**



**READ THE USER'S MANUAL BEFORE INSTALLING THE UNIT.**

Sufficient service access to the unit for maintenance or repair operations must be provided.

The recommended minimum distances from the unit to the walls are shown below.

Make sure the unit has no foreign objects inside before starting it up.

The unit is designed for mounting to a horizontal surface adjacent to the wall with the ready-made holes for the air ducts. To fix the unit to the wall, there are mounting brackets with a hole for a screw (not included into delivery kit).

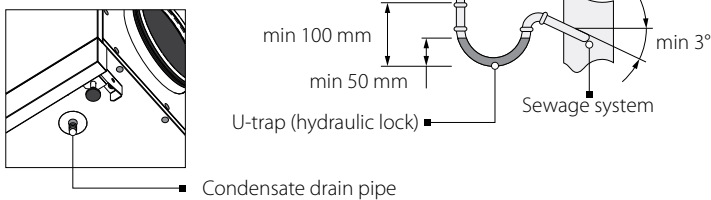
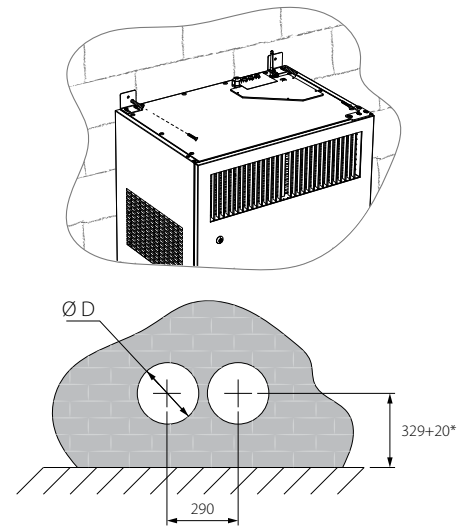
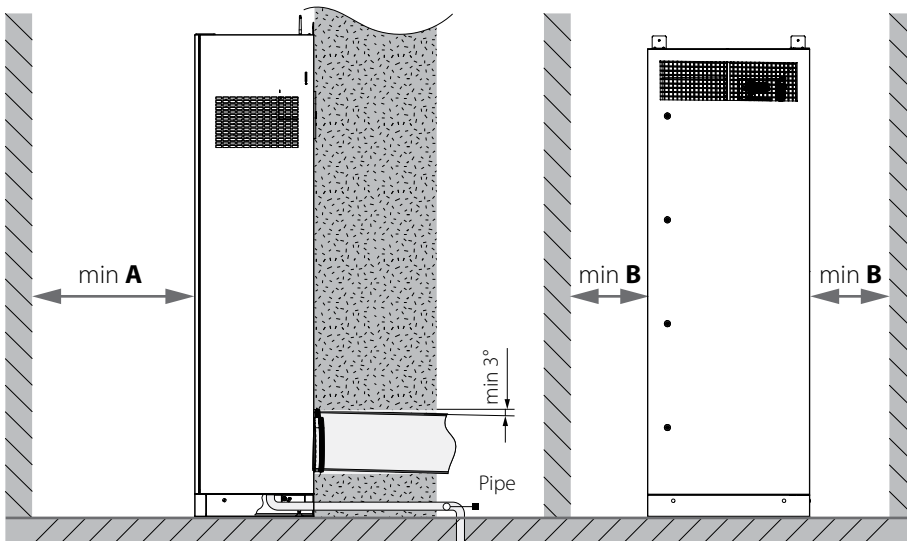
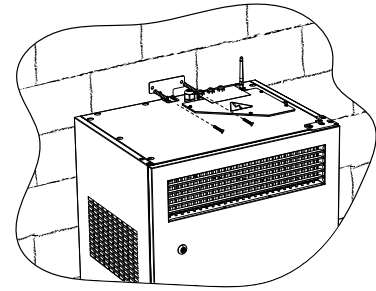
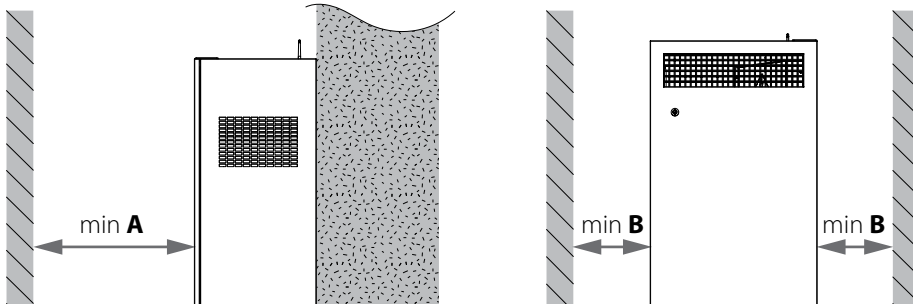

MODEL	A [mm]	B [mm]	D [mm]
Civic 300 LB(E/E2) EC V.2	600	350	225
Civic 500 LB(E/E2) EC V.2	800	350	275

\* The dimension may be increased during adjustment of the unit by means of the levelling feet.

Remove the protective panels to access the bottom of the unit. At the end of the installation, install the panels in reverse order.

**Caution:** Do not operate the unit with the panels removed.

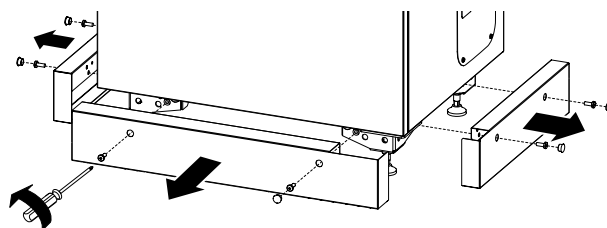



The levelling feet on the bottom of the unit ensure exact alignment of the unit during mounting.

For alignment of the unit loosen the nuts and adjust position of the support disc manually using a wrench. Then tighten the upper and the lower nut.

To attain the best performance of the unit and to minimise turbulence-induced air pressure losses, while mounting connect straight air duct sections to the unit spigots.

Minimum straight air duct length:

- equal to 1 air duct diameter on intake side
- equal to 3 air duct diameters on outlet side

If the air ducts are too short or not connected at any unit spigot,

protect the unit inner parts from ingress of foreign objects by installing a protecting grille or other protecting device with mesh side width not more than 12.5 mm to prevent uncontrollable access to the fans.

Fasteners for the unit mounting are not included into delivery set and should be ordered separately.

While selecting appropriate fasteners consider material of the mounting surface as well as the weigh of the unit, refer to the technical data. For selection of the fasteners for unit mounting please refer to a service technician.

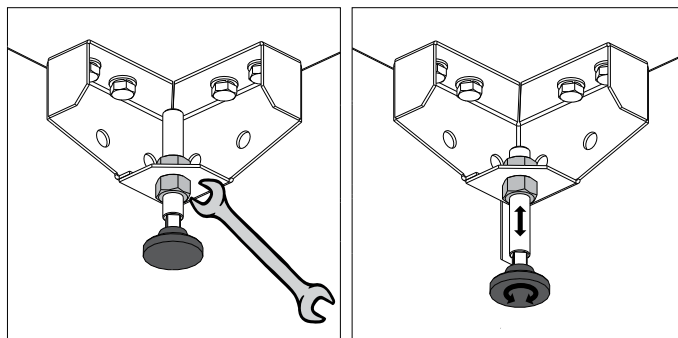

The drain pan in the heat recovery section is equipped with a drain pipe for condensate removal.

Connect the pipe, the U-trap or U-trap of the other type (hydraulic lock) that is not included in the delivery set and a sewage system with metal, plastic or rubber connecting hoses. While laying the connection pipes provide the slope of minimum 3° downwards.

Before starting operation of the unit make sure that the water flows freely into the sewage collection system, otherwise condensed water may build up in the unit during the heat exchanger operation which, in turn, may cause equipment failure and water ingress into the premises. Fill up the U-trap with water before using it. When using other U-trap systems read the installation instruction to prepare the condensate drain system for operation.

For the units with a drain pump make sure that the flexible hose from the pump must be connected to the sewage system.

The drain pump provides timely pumping of the condensed water from the unit.

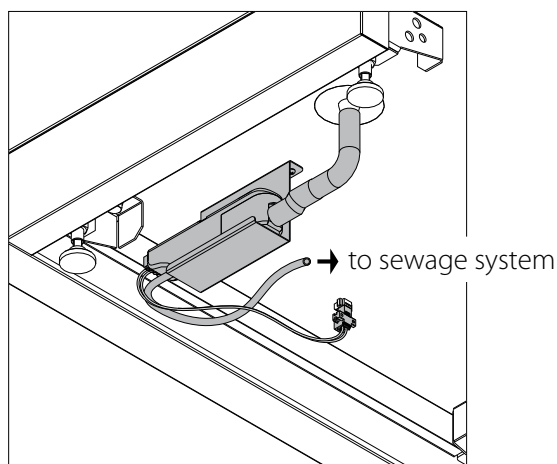

**THE CONDENSATE DRAIN SYSTEM IS DESIGNED FOR USE IN PREMISES WITH AMBIENT TEMPERATURE ABOVE 0 °C!  
IF THE EXPECTED AIR TEMPERATURES ARE BELOW 0 °C, THE CONDENSATE DRAINAGE SYSTEM MUST BE EQUIPPED WITH HEAT INSULATION AND PREHEATING FACILITIES.**

**INSTALLATION OF SENSORS (not included in the delivery set)**

The bracket for installing humidity, CO2, VOC sensors is located on the wall of the exhaust air duct upstream the heat exchanger.

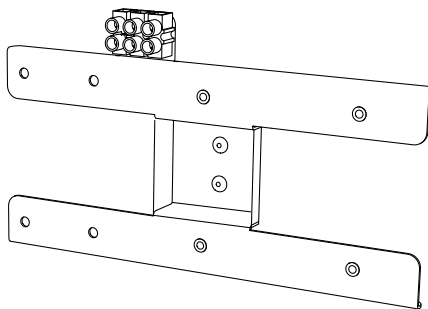

Secure the CO2-3 sensor circuit board on the bracket and connect the cable with the connector (installed by the manufacturer)

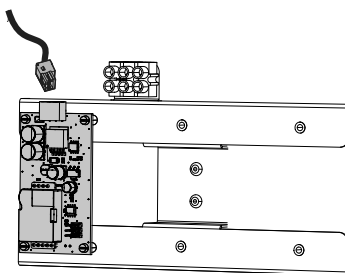

Secure the HV2 humidity sensor on the bracket and connect the cable with the connector (installed by the manufacturer)

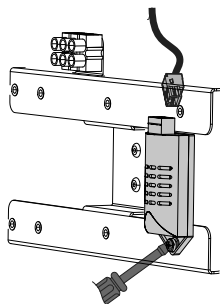

To install the VOC sensor, disassemble the sensor according to the instructions provided in its delivery set. Disconnect the cable from the terminal box and connect it to the sensor according to the diagram below. Reassemble the sensor in the reverse order and secure it on the bracket.

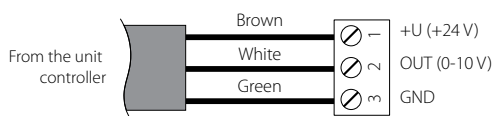
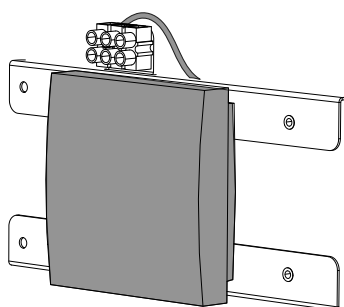

## CONNECTION TO POWER MAINS



**ANY TAMPERING WITH THE INTERNAL CONNECTIONS IS PROHIBITED  
AND WILL VOID THE WARRANTY.**

**The unit without a drain pump is designed to be connected to power mains with parameters 1~230 V/50 (60) Hz, with a drain pump — 1~230 V/50 Hz.**

The unit must be connected to the power mains using insulated, durable and heat-resistant conductors (cable, wires). The cross-section of the conductors must correspond to the power consumption of the system (see technical specifications). When selecting the required cross-section, it is necessary to take into account the type of the conductor, its maximum permissible heat load, insulation, length, and method of routing. The external power input must be equipped with an automatic circuit breaker built into the stationary wiring to open the electric circuit in case of overload or short-circuit. The circuit breaker installation place must provide quick access for emergency shutdown of the unit. The trip current of the automatic circuit breaker must correspond to the current consumption of the unit (see the technical data). For accessing the terminal block and the controller undo the screws of the terminal box cover and remove it. The terminal block and the controller for external devices connection are located in the control unit.

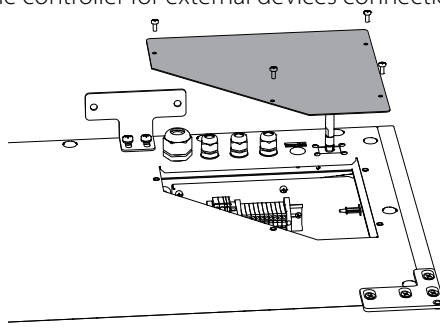

Route the cables to the control unit through the sealed cabled glands in the unit.  
Carry out the electrical connections as shown in the wiring diagram.



**DO NOT LAY THE CABLE IN CLOSE PROXIMITY TO THE CONTROL PANEL CABLE!  
WHILE ROUTING THE CONTROL PANEL CABLE DO NOT COIL THE EXTRA LENGTH.**

EXTERNAL WIRING DIAGRAM

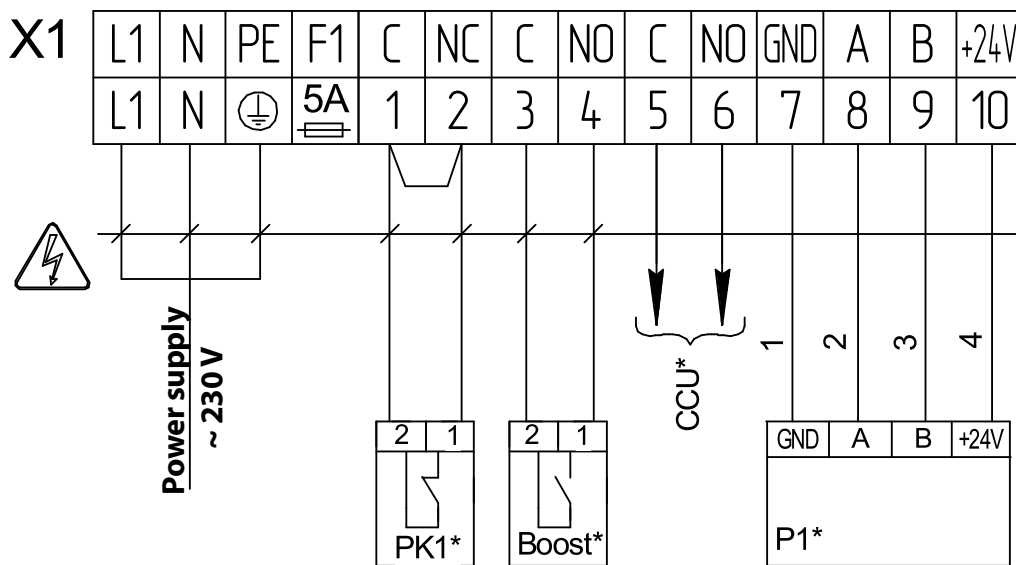

Designation	Name	Wire	Type of contact	Note
PK1*	Contact from fire alarm panel	2 x 0,75 mm <sup>2</sup>	NC	Remove the jumper
CCU*	Cooler control	2 x 0,75 mm <sup>2</sup>	NO	3 A, 30 DC
P1*	External control panel	4 x 0,5 mm <sup>2</sup>		
Boost*	On/Off contacts for the Boost mode	2 x 0,75 mm <sup>2</sup>	NO	

\*Is not included in the delivery set.



## TECHNICAL MAINTENANCE

Maintenance operations of the unit are required 3-4 times per year. Maintenance includes general cleaning of the unit and the following operations:

### 1. Filter maintenance.

Clogged filters increase air resistance in the system and reduce supply air volume.

Clean the filters as required, but not less than 3-4 times per year.

Upon elapsing of the set time for filter replacement a signal for filter replacement or cleaning is generated. In this case clean or replace the filters and reset the operating hours.

The filter timer must be reset by a service engineer.

Filter cleaning with a vacuum cleaner is allowed.

After two consecutive cleanings the filters must be replaced.

For new filters of the type stated in the technical data, please contact to the unit Seller.

Steps for removal of the filters:

- Disconnect the unit from power supply.
- Open the service door using the key.

**CAUTION: For units with a heater, the supply filters are replaced after the unit has been switched off for two minutes!**

- Press slightly and pull the fixing latches to remove the supply filters.

Turn the locking pieces and pull out the extraction filters (Civic EC LB(E/E2) 300-E)

Remove the exhaust filter by pulling it towards you (Civic EC LB(E/E2) 500).

- Install the filters in the reverse order.

**Civic EC LB(E/E2) 300, Civic EC LB(E/E2) 300-E**

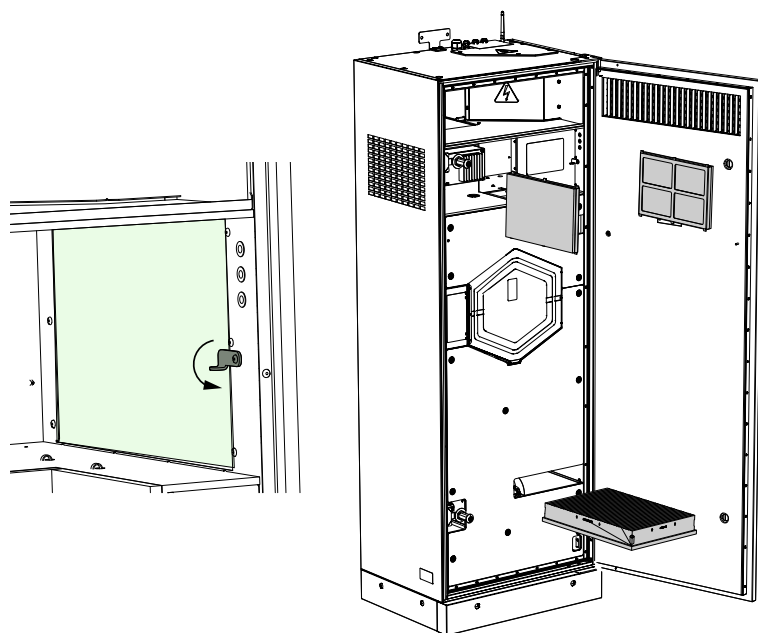

**Civic EC LB(E/E2) 500**

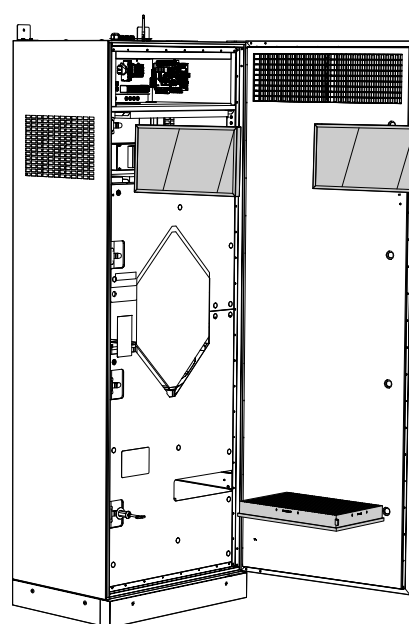

## 2. Heat exchanger maintenance (once per year).

Some dust may accumulate on the heat exchanger even in case of regular maintenance of the filters. Regular cleaning of the heat exchanger is required to maintain high heat recovery efficiency. To clean the heat exchanger, pull it out of the unit and clean it with compressed air or a vacuum cleaner. After cleaning install the heat exchanger back in the unit.

### Steps for removal of the heat exchanger:

- Disconnect the unit from power supply.
- Open the service door using the key.
- Remove the 6 screws that retain the upper protective housing and take it off.
- Loosen the hand screws to release the heat exchanger, then pull the heat exchanger to remove.
- After completion of maintenance install the heat exchanger in the reverse order.

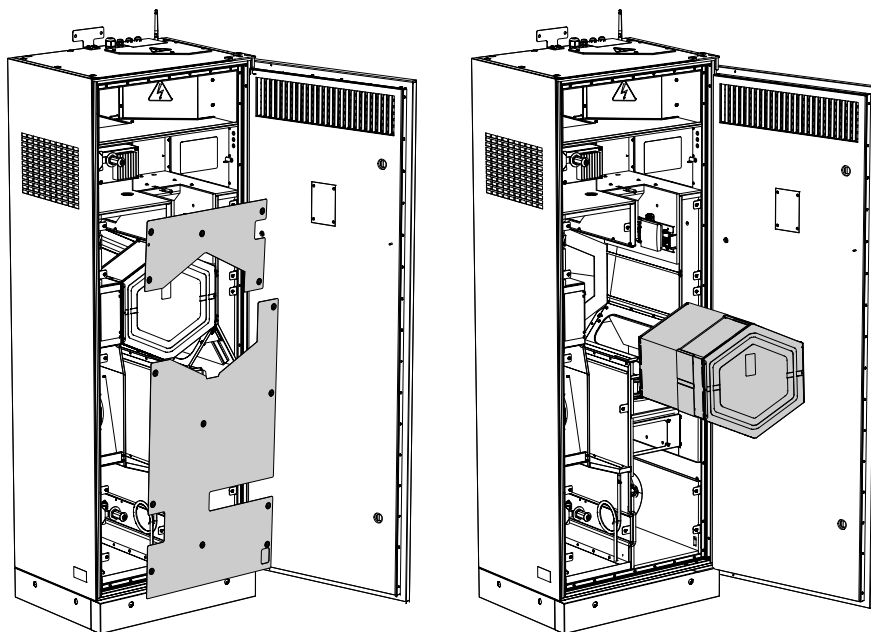

## 3. Fan maintenance (once a year).

Even in case of regular maintenance of the filters, some dust may accumulate inside the fans and reduce the fan performance and supply air flow. Clean the fans with a soft cloth, brush or compressed air.

Do not use water, aggressive solvents or sharp objects as they may damage the impeller.

## 4. Maintenance of air intake devices (twice per year).

The supply grille may get clogged with leaves and other objects, which reduces the unit performance and supply air delivery. Check the supply grille twice per year and clean it as required.

## 5. Air duct system maintenance (every 5 years).

Even regular fulfilling of all the maintenance operations described above may not completely prevent dust accumulation in the air ducts, which reduces the unit performance. Duct maintenance means regular cleaning or replacement.

## 6. Control unit maintenance (as required).

The control unit is located inside of the unit casing. For accessing the control unit remove the fixing screws on the panel and remove the control unit lid.

## TROUBLESHOOTING

TROUBLE	POSSIBLE REASONS	Troubleshooting
The fan(s) do(es) not get started during activation of the unit.	No power supply.	Make sure the power supply line is connected correct. Otherwise troubleshoot a connection error.
	Motor or impeller clogging.	Turn the unit off. Troubleshoot the fan clogging. Clean the blades. Restart the unit.
	System failure.	Turn the unit off. Contact the product Seller.
Automatic circuit breaker tripping after the unit start-up.	Overcurrent as a result of short circuit in the electric circuit.	Turn the unit off. Contact the product Seller.
Low air flow.	Low set fan speed.	Set higher speed.
	Clogged filters, fans or heat exchanger.	Clean or replace the filters. Clean the fans and the heat exchanger.
	Clogged or damaged air ducts, diffusers, louver shutters, grilles or other ventilation system components.	Clean or replace the air ducts, diffusers, louver shutters, grilles or other ventilation system components.
Low supply air temperature.	Clogged extract filter.	Clean or replace the extract filter.
Noise, vibration.	The impeller(s) is soiled.	Clean the impeller(s).
	The fan or casing screw connection is loose.	Tighten the screw connection of the fans or the casing all the way.
	No anti-vibration connectors on air duct pipe flanges.	Install anti-vibration connectors.
Water leakage.	Drain lime is clogged, damaged or installed incorrect.	Clean the drain line. Check the drain line slope. Make sure that the U-trap is filled with water and that drain hoses are frost protected.
The alarm indicator  glows on the control panel (for the units with S14 control panel).	Communication loss (cable or wire breakdown) between the control panel and the ventilation unit.	Check the power and connection cables and wires between the control panel and the air handling unit for integrity using a multimeter. If unassisted troubleshooting fails, please contact the product Seller.
	Wrong cable installation.	Make sure the cable installation is completed according to the requirements stated in the user's manual for the control panel. Otherwise install the cable as required.
	System failure.	Contact the product Seller.

## STORAGE AND TRANSPORTATION REGULATIONS

- Store the unit in the manufacturer's original packaging box in a dry closed ventilated premise with temperature range from +5 °C to +40 °C and relative humidity up to 70 %.
- Storage environment must not contain aggressive vapors and chemical mixtures provoking corrosion, insulation, and sealing deformation.
- Use suitable hoist machinery for handling and storage operations to prevent possible damage to the unit.
- Follow the handling requirements applicable for the particular type of cargo.
- The unit can be carried in the original packaging by any mode of transport provided proper protection against precipitation and mechanical damage. The unit must be transported only in the working position.
- Avoid sharp blows, scratches, or rough handling during loading and unloading.
- Prior to the initial power-up after transportation at low temperatures, allow the unit to warm up at operating temperature for at least 3-4 hours.

## MANUFACTURER'S WARRANTY

The product is in compliance with EU norms and standards on low voltage guidelines and electromagnetic compatibility. We hereby declare that the product complies with the provisions of Electromagnetic Compatibility (EMC) Directive 2014/30/EU of the European Parliament and of the Council, Low Voltage Directive (LVD) 2014/35/EU of the European Parliament and of the Council and CE-marking Council Directive 93/68/EEC. This certificate is issued following test carried out on samples of the product referred to above.

The manufacturer hereby warrants normal operation of the unit for 24 months after the retail sale date provided the user's observance of the transportation, storage, installation, and operation regulations. Should any malfunctions occur in the course of the unit operation through the Manufacturer's fault during the guaranteed period of operation, the user is entitled to get all the faults eliminated by the manufacturer by means of warranty repair at the factory free of charge. The warranty repair includes work specific to elimination of faults in the unit operation to ensure its intended use by the user within the guaranteed period of operation. The faults are eliminated by means of replacement or repair of the unit components or a specific part of such unit component.

### The warranty repair does not include:

- routine technical maintenance
- unit installation/dismantling
- unit setup

To benefit from warranty repair, the user must provide the unit, the user's manual with the purchase date stamp, and the payment paperwork certifying the purchase. The unit model must comply with the one stated in the user's manual. Contact the Seller for warranty service.

### The manufacturer's warranty does not apply to the following cases:

- User's failure to submit the unit with the entire delivery package as stated in the user's manual including submission with missing component parts previously dismantled by the user.
- Mismatch of the unit model and the brand name with the information stated on the unit packaging and in the user's manual.
- User's failure to ensure timely technical maintenance of the unit.
- External damage to the unit casing (excluding external modifications as required for installation) and internal components caused by the user.
- Redesign or engineering changes to the unit.
- Replacement and use of any assemblies, parts and components not approved by the manufacturer.
- Unit misuse.
- Violation of the unit installation regulations by the user.
- Violation of the unit control regulations by the user.
- Unit connection to power mains with a voltage different from the one stated in the user's manual.
- Unit breakdown due to voltage surges in power mains.
- Discretionary repair of the unit by the user.
- Unit repair by any persons without the manufacturer's authorization.
- Expiration of the unit warranty period.
- Violation of the unit transportation regulations by the user.
- Violation of the unit storage regulations by the user.
- Wrongful actions against the unit committed by third parties.
- Unit breakdown due to circumstances of insuperable force (fire, flood, earthquake, war, hostilities of any kind, blockades).
- Missing seals if provided by the user's manual.
- Failure to submit the user's manual with the unit purchase date stamp.
- Missing payment paperwork certifying the unit purchase.



**FOLLOWING THE REGULATIONS STIPULATED HEREIN WILL ENSURE A LONG AND TROUBLE-FREE OPERATION OF THE UNIT.**



**USER'S WARRANTY CLAIMS SHALL BE SUBJECT TO REVIEW ONLY UPON PRESENTATION OF THE UNIT, THE PAYMENT DOCUMENT AND THE USER'S MANUAL WITH THE PURCHASE DATE STAMP.**



**CERTIFICATE OF ACCEPTANCE**

<b>Unit Type</b>	Single-room heat recovery air handling unit
<b>Model</b>	
<b>Serial Number</b>	
<b>Manufacture Date</b>	
<b>Quality Inspector's Stamp</b>	

**SELLER INFORMATION**

<b>Seller</b>	
<b>Address</b>	
<b>Phone Number</b>	
<b>E-mail</b>	
<b>Purchase Date</b>	
This is to certify acceptance of the complete unit delivery with the user's manual. The warranty terms are acknowledged and accepted.	
<b>Customer's Signature</b>	

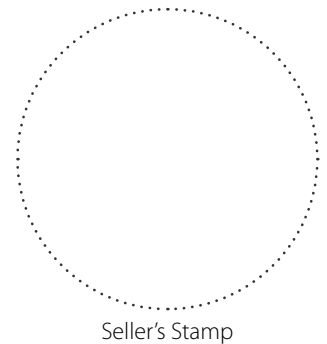

**INSTALLATION CERTIFICATE**

The _____ unit is installed pursuant to the requirements stated in the present user's manual.	
<b>Company name</b>	
<b>Address</b>	
<b>Phone Number</b>	
<b>Installation Technician's Full Name</b>	
<b>Installation Date:</b>	<b>Signature:</b>
The unit has been installed in accordance with the provisions of all the applicable local and national construction, electrical and technical codes and standards. The unit operates normally as intended by the manufacturer.	
<b>Signature:</b>	

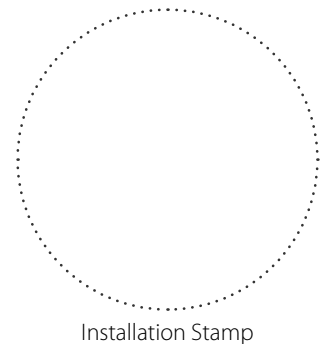

**WARRANTY CARD**

<b>Unit Type</b>	Single-room heat recovery air handling unit
<b>Model</b>	
<b>Serial Number</b>	
<b>Manufacture Date</b>	
<b>Purchase Date</b>	
<b>Warranty Period</b>	
<b>Seller</b>	

