



## HEAT AND ENERGY RECOVERY AIR HANDLING UNIT



**KOMFORT ERV EC DB 100 S14**  
**KOMFORT ERV EC DB 150 S14**  
**KOMFORT ERV EC DB 250 S14**  
**KOMFORT ERV EC DB 350 S14**

**EN**

**USER'S MANUAL**

**CONTENTS**

Safety requirements.....	3
Purpose.....	5
Delivery set.....	5
Designation key.....	5
Technical data.....	6
Design and operating principle.....	8
Mounting and set-up.....	10
Connection to power mains.....	11
Technical maintenance.....	12
Troubleshooting.....	13
Storage and transportation regulations.....	13
Manufacturer's warranty.....	14
Certificate of acceptance.....	15
Seller information.....	15
Installation certificate.....	15
Warranty card.....	15

This user's manual is a main operating document intended for technical, maintenance, and operating staff.

The manual contains information about purpose, technical details, operating principle, design, and installation of the KOMFORT ERV EC DB unit and all its modifications.

Technical and maintenance staff must have theoretical and practical training in the field of ventilation systems and should be able to work in accordance with workplace safety rules as well as construction norms and standards applicable in the territory of the country.

The information in this user's manual is correct at the time of the document's preparation.

The Company reserves the right to modify the technical characteristics, design, or configuration of its products at any time in order to incorporate the latest technological developments.

No part of this publication may be reproduced, stored in a retrieval system, or transmitted, in any form or by any means in any information search system or translated into any language in any form without the prior written permission of the Company.

## SAFETY REQUIREMENTS

- Please read the user's manual carefully prior to installing and operating the unit.
- All user's manual requirements as well as the provisions of all the applicable local and national construction, electrical, and technical norms and standards must be observed when installing and operating the unit.
- The warnings contained in the user's manual must be considered most seriously since they contain vital personal safety information.
- Failure to follow the rules and safety precautions noted in this user's manual may result in an injury or unit damage.
- After a careful reading of the manual, keep it for the entire service life of the unit.
- While transferring the unit control, the user's manual must be turned over to the receiving operator.

### UNIT INSTALLATION AND OPERATION SAFETY PRECAUTIONS



- Disconnect the unit from power mains prior to any installation operations.



- Unpack the unit with care.



- The unit must be grounded!



- While installing the unit, follow the safety regulations specific to the use of electric tools.



- Do not change the power cable length at your own discretion.
- Do not bend the power cable.
- Avoid damaging the power cable.
- Do not put any foreign objects on the power cable.



- Do not lay the power cable of the unit in close proximity to heating equipment.

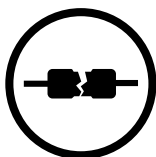

- Do not use damaged equipment or cables when connecting the unit to power mains.

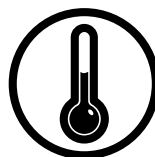

- Do not operate the unit outside the temperature range stated in the user's manual.
- Do not operate the unit in aggressive or explosive environments.



- Do not touch the unit controls with wet hands.
- Do not carry out the installation and maintenance operations with wet hands.



- Do not wash the unit with water.
- Protect the electric parts of the unit against ingress of water.



- Do not allow children to operate the unit.



- Do not store any explosive or highly flammable substances in close proximity to the unit.

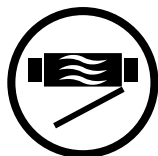

- Do not open the unit during operation.



- Do not block the air duct when the unit is switched on.



- Do not sit on the unit and avoid placing foreign objects on it.

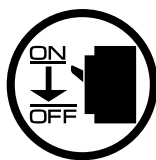

- Disconnect the unit from power mains prior to any technical maintenance.



- When the unit generates unusual sounds, odour, or emits smoke, disconnect it from power supply and contact the Seller.



- Do not direct the air flow produced by the unit towards open flame or ignition sources.



- In case of continuous operation of the unit, periodically check the security of mounting.



- Use the unit only for its intended purpose.



**THE PRODUCT MUST BE DISPOSED SEPARATELY AT THE END OF ITS SERVICE LIFE.  
DO NOT DISPOSE THE UNIT AS UNSORTED DOMESTIC WASTE.**

**PURPOSE**

The unit is designed to ensure continuous mechanical air exchange in houses, offices, hotels, cafes, conference halls, and other utility and public spaces as well as to recover the heat energy contained in the air extracted from the premises to warm up the filtered stream of intake air.

The unit is not intended for organizing ventilation in swimming pools, saunas, greenhouses, summer gardens, and other spaces with high humidity.

Due to the ability to save heating energy by means of energy recovery, the unit is an important element of energy-efficient premises.

The unit is a component part and is not designed for stand-alone operation. It is rated for continuous operation.

Transported air must not contain any flammable or explosive mixtures, evaporation of chemicals, sticky substances, fibrous materials, coarse dust, soot and oil particles or environments favourable for the formation of hazardous substances (toxic substances, dust, pathogenic germs).



**THE UNIT SHOULD NOT BE OPERATED BY CHILDREN OR PERSONS WITH REDUCED PHYSICAL, MENTAL, OR SENSORY CAPACITIES, OR THOSE WITHOUT THE APPROPRIATE TRAINING.**

**THE UNIT MUST BE INSTALLED AND CONNECTED ONLY BY PROPERLY QUALIFIED PERSONNEL AFTER THE APPROPRIATE BRIEFING.**

**THE CHOICE OF UNIT INSTALLATION LOCATION MUST PREVENT UNAUTHORIZED ACCESS BY UNATTENDED CHILDREN.**

**DELIVERY SET**

<b>Name</b>	<b>Number</b>
Air handling unit	1 item
User's manual	1 item
Control panel	1 item
Packing box	1 item

**DESIGNATION KEY**

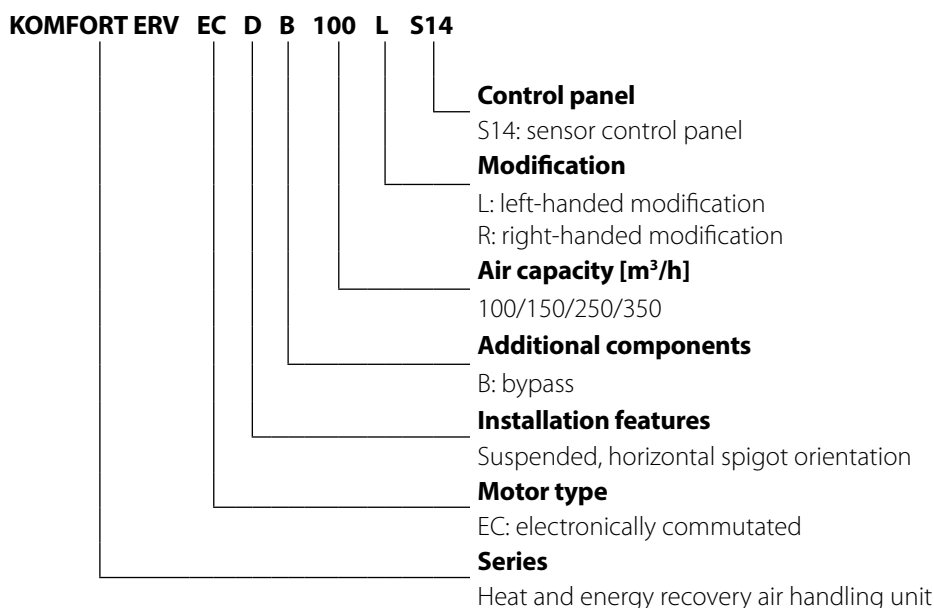

**TECHNICAL DATA**

The unit is designed for application with the ambient temperature ranging from +1 °C to +40 °C and relative humidity up to 80 %. In order to prevent condensation on the internal walls of the unit, it is necessary that the surface temperature of the casing is 2-3 °C above the dew point temperature of the transported air.

The unit is rated as a Class I electrical appliance.

Hazardous parts access and water ingress protection rating:

- IP22 for the unit connected to the air ducts;
- IP44 for the unit motors.

The unit design is constantly being improved, thus some models may be slightly different from those described in this manual.

Parameter	KOMFORT ERV EC DB 100	KOMFORT ERV EC DB 150	KOMFORT ERV EC DB 250	KOMFORT ERV EC DB 350
Unit voltage [V/50-60 Hz]	1~ 230			
Maximum unit power [W]	66	83	84	171
Maximum unit current [A]	0.5	0.7	0.7	1.3
Maximum air capacity [m <sup>3</sup> /h]	170	215	300	430
RPM	2800	2000	2000	3200
Sound pressure level at 3 m distance [dBA]	30	32	36	46
Transported air temperature [°C]	-25...+40			
Extract air filter	G4			
Supply air filters	G4 and F8 (PM2.5 93 %)			
Connected air duct diameter [mm]	100	100	150	150
Heat recovery efficiency [%]	70-82	68-82	63-73	68-85
Humidity recovery efficiency [%]	24-41	22-41	16-27	19-34
Heat exchanger type	cross-flow enthalpy			
Weight [kg]	17	26	29	42
Energy efficiency class	A			

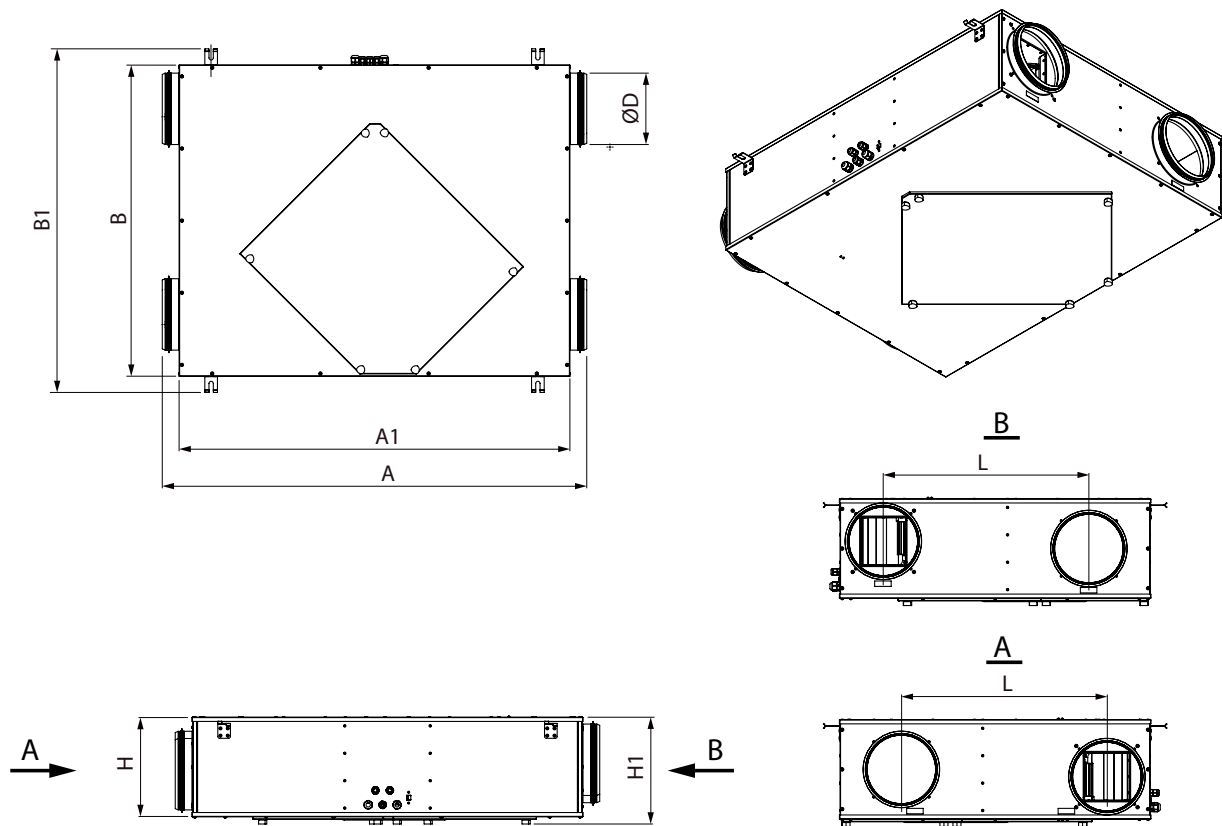

Model	Dimensions [mm]							
	Ø D	A	A1	B	B1	H	H1	L
<b>KOMFORT ERV EC DB 100</b>	100	734	600	481	571	204	223	300
<b>KOMFORT ERV EC DB 150</b>	100	987	854	704	793	222	241	480
<b>KOMFORT ERV EC DB 250</b>	150	987	854	704	793	227	246	480
<b>KOMFORT ERV EC DB 350</b>	150	1157	1024	754	843	277	296	488

## DESIGN AND OPERATING PRINCIPLE

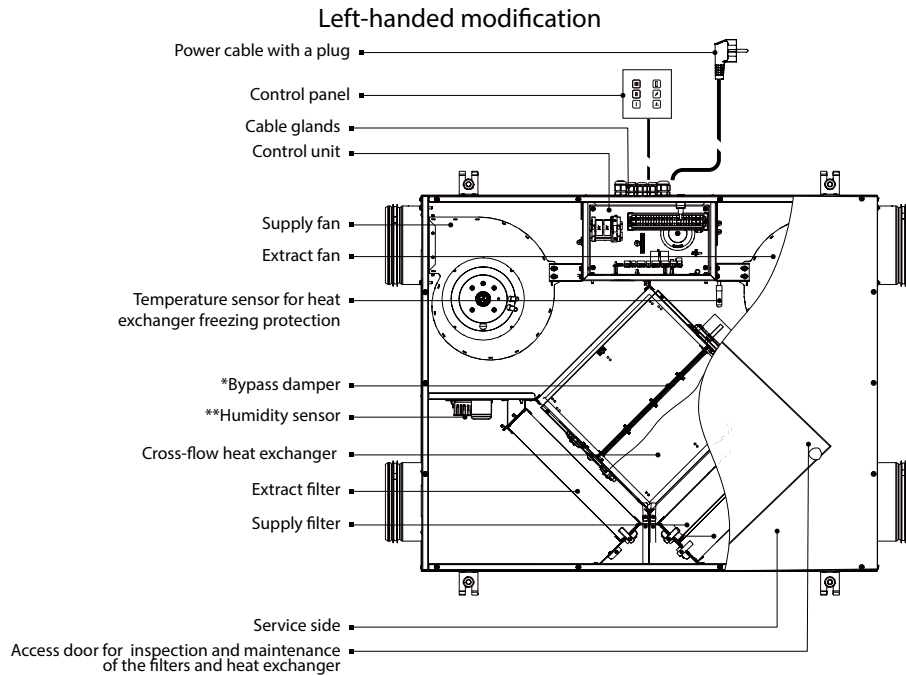

The service panel is equipped with a detachable access door with manual bolts for cleaning or replacement of the filters and heat exchanger. The control unit is positioned inside the unit casing.

The power and the ground cable are to connect to the control unit through the cable glands in the unit casing side.

The plate enthalpy cross-flow heat exchanger is made of polymerized cellulose.

\*The bypass damper is open or closed depending on operation mode of the unit.

\*\*At the request of the customer the unit can be equipped with a humidity sensor. The humidity sensor is purchased separately as an accessory. The unit with an installed humidity sensor maintains a set indoor humidity point. As the extract air humidity rises above the set point, the system automatically switches to the maximum speed. As the humidity drops down below the set point the unit returns to the previous operation mode. Installation and connection of the humidity sensor is carried out on site by the service technician.

### LEFT-HANDED AND RIGHT-HANDED MODIFICATIONS

Choosing the right arrangement can improve the ease of installation, shorten the length of the ducts and reduce the number of air duct bends.

### UNIT OPERATION MODES

**Heat recovery:** warm extract air from the room flows into the unit and is cleaned in the extract filter. Then the air is moved through the heat exchanger and is exhausted outside with the extract fan. Cold fresh air from outside flows into the unit, where it is cleaned in the supply filter. Then the air flows through the heat exchanger and is moved to the room with the supply fan.

Supply air is heated in the heat exchanger by transferring the heat energy of warm and humid extract air to the cold fresh air.

The air flows are fully separated while flowing through the heat exchanger. Heat recovery minimizes heat losses, which reduces the cost of space heating in the cold season. The enthalpy heat exchanger allows to recover humidity as well as heat.

In the summer period, the supplied fresh air is cooled and dried by the heat exchanger, in the winter period it is heated and moisturized. The water vapour is devaporated from the stale wet air and absorbed with heat exchanger plates.

The released heat and moisture are transferred to the supply air. The transferring of dirt, odours and microorganisms from one air flow to another is excluded.

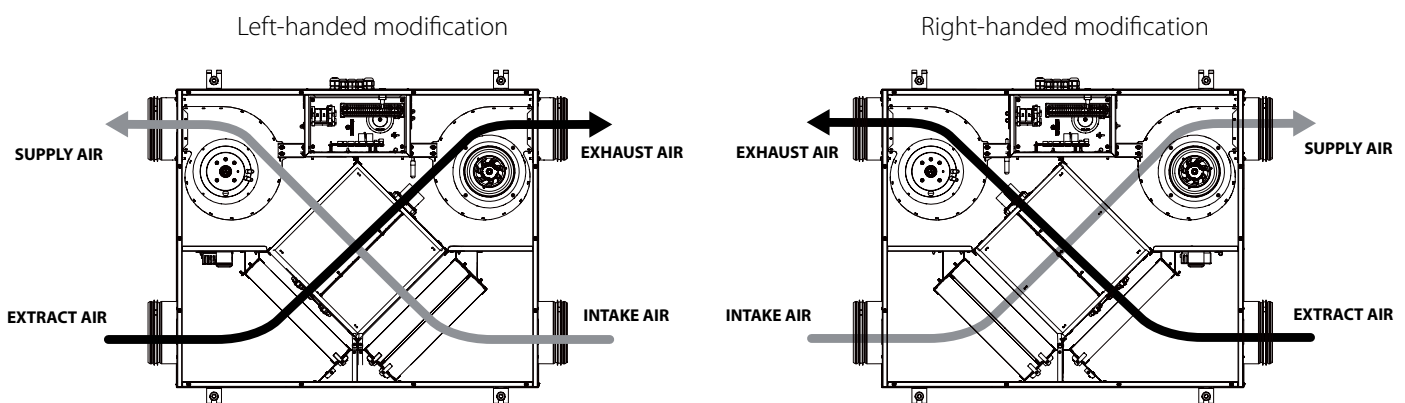



**Defrosting mode:** to prevent the heat exchanger freezing in the cold season the unit has an automatic Defrosting mode according to the freeze protection temperature sensor readings in the exhaust air duct downstream of the heat exchanger. The unit switches to the defrosting mode at the extract air temperature +3 °C. As the temperature rises the unit returns to the previous mode. Only the extract fan operates in the defrosting mode, the supply fan is switched off.

Left-handed modification

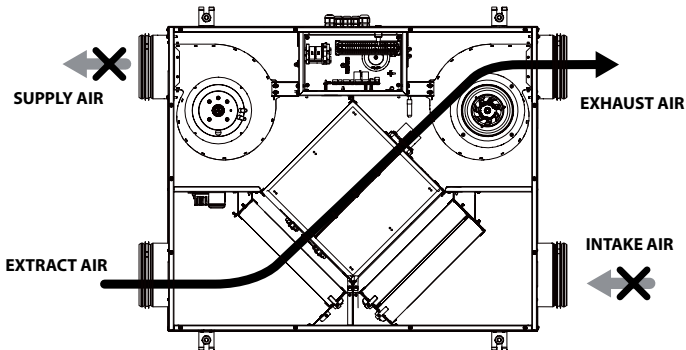

Right-handed modification

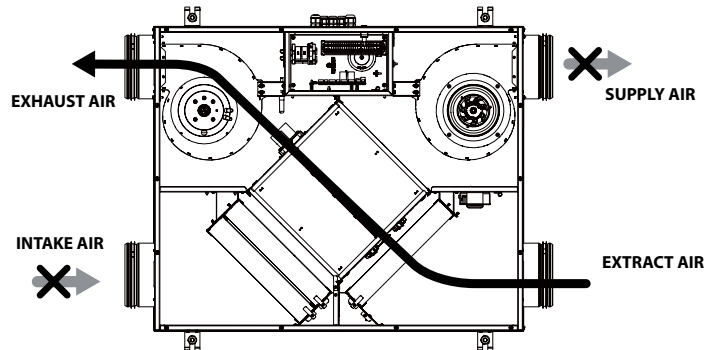

**Summer Cooling mode:** in the units with a bypass damper, the part of the intake air that is supplied to the premises bypasses the heat exchanger.

Left-handed modification

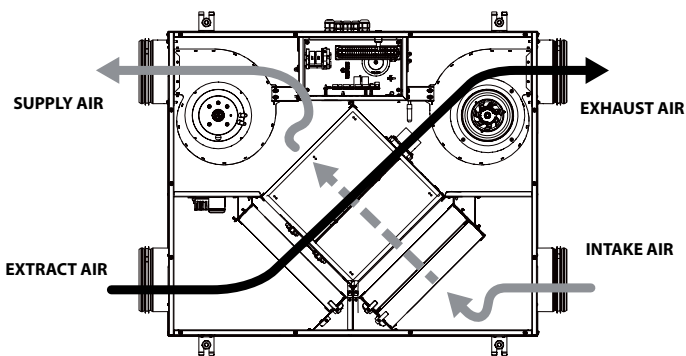

Right-handed modification

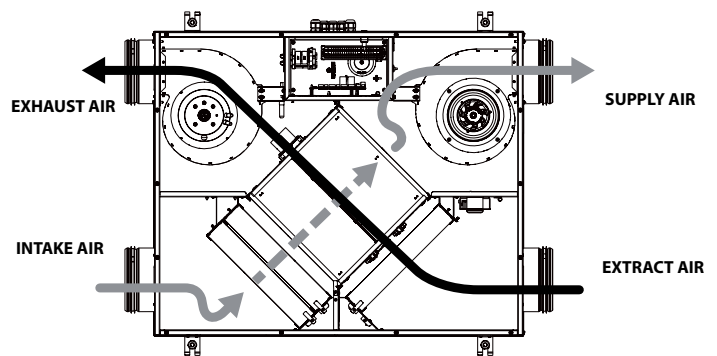

## MOUNTING AND SET-UP



**READ THE USER'S MANUAL BEFORE INSTALLING THE UNIT.**



**WHILE INSTALLING THE UNIT ENSURE CONVENIENT ACCESS FOR SUBSEQUENT MAINTENANCE AND REPAIR.**

### HUMIDITY SENSOR MOUNTING

The humidity sensor is not included in the delivery set and can be ordered separately.

The humidity sensor must be installed prior to unit mounting.

Unit mounting sequence:

- Remove the mounting screws of the service side panel of the unit and take it off.
- Install the humidity sensor into the mount from the side of the extract air duct and connect the humidity sensor connector to the respective connector coming from the control unit, refer to the External wiring diagram.
- Install the sensor cover back.

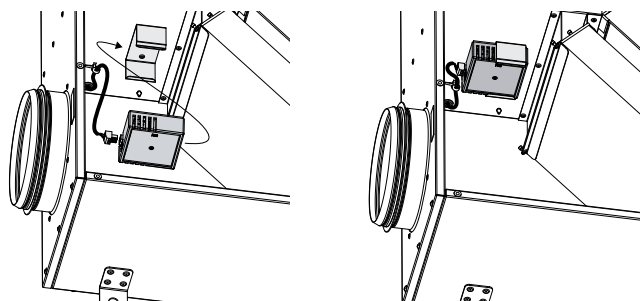

### UNIT MOUNTING

The unit is designed for ceiling mounting with anchor threaded bolts, nuts and vibration-absorbing rubber.

Fasteners for unit mounting are not included in the delivery set and should be ordered separately.

While choosing fasteners consider the material of the mounting surface as well as the weight of the unit, refer to the Technical Data section. Fasteners for unit mounting should be selected by the service technician.

Before mounting make sure that the casing is free of any foreign objects like film or paper.

While installing the unit ensure convenient access for subsequent maintenance and repair.

Minimum required distance from the unit to the ceiling is at least 20 mm.

To attain the best performance of the unit and to minimise turbulence-induced air pressure losses, connect the straight air duct section to the spigots on both sides of the unit while mounting.

Minimum straight air duct length:

- equal to 1 air duct diameter on intake side
- equal to 3 air duct diameters on outlet side

If the air ducts are too short or not connected, protect the unit parts from ingress of foreign objects.

To prevent uncontrollable access to the fans the spigots may be covered with a protecting grille or other protecting device with mesh width not more than 12.5 mm.

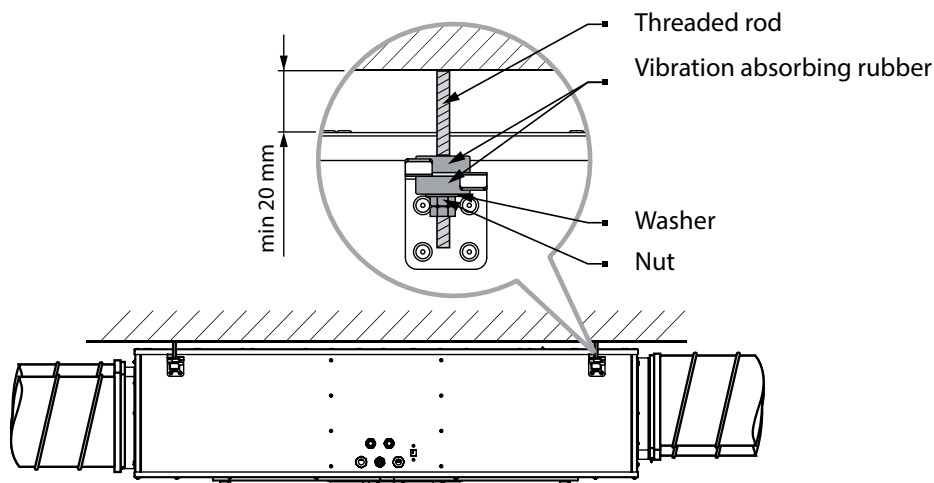

**CONNECTION TO POWER MAINS**



**POWER OFF THE POWER SUPPLY PRIOR TO ANY OPERATIONS WITH THE UNIT.  
THE UNIT MUST BE CONNECTED TO POWER SUPPLY BY A QUALIFIED ELECTRICIAN.  
THE RATED ELECTRICAL PARAMETERS OF THE UNIT ARE GIVEN ON THE  
MANUFACTURER'S LABEL.**

- The unit is rated for connection to 1~230 V/50-60 Hz according to the wiring diagram.
- The connection must be made using insulated conductors (cables, wires).
- The actual wire cross section selection must be based on the maximum load current, maximum conductor temperature depending on the wire type, insulation, length and installation method.
- The external power input must be equipped with an automatic circuit breaker QF built into the stationary wiring to open the circuit in the event of overload or short-circuit.
- The position of the automatic circuit breaker must ensure free access for quick power-off of the unit.
- The trip current of the automatic circuit breaker must exceed the maximum current consumption of the unit (refer to the "Technical data" section or to the unit label).
- It is recommended to select the nominal current of the circuit breaker from the standard series, following the maximum current of the connected unit.
- The circuit breaker is not included in the delivery set and can be ordered separately.

**External wiring diagram**

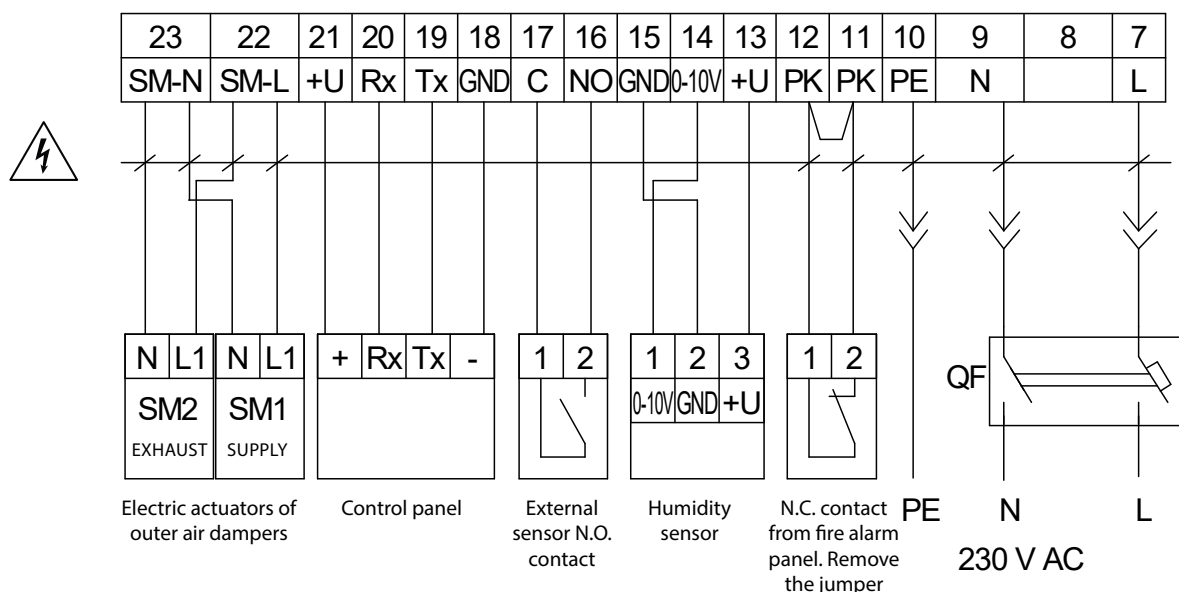

## TECHNICAL MAINTENANCE



**DISCONNECT THE UNIT FROM POWER SUPPLY BEFORE ANY MAINTENANCE OPERATIONS!**

The unit must undergo technical maintenance 3 to 4 times a year. It includes general cleaning of the unit and the following operations:

### 1. Filter maintenance (3-4 times per year).

Dirty filters increase air resistance in the system and reduce supply air volume. The filters require replacing not less than 3-4 times per year.

To replace the filters, open the access door on the service panel and remove the dirty filters, then install new filters and close the access door.

For new filters contact the Seller.

### 2. Heat exchanger maintenance (once a year).

Some dust may accumulate on the heat exchanger block even in case of regular maintenance of the filters.

To maintain the high heat exchange efficiency, regular heat exchanger vacuum cleaning using a crevice nozzle is recommended.

### 3. Fan maintenance (once a year).

Even in case of regular maintenance of the filters, some dust may accumulate inside the fans and reduce the fan performance and supply air flow.

Clean the fans with a soft brush or cloth.

Do not use water, aggressive solvents or sharp objects as they may damage the impeller.

### 4. Technical maintenance of air duct system (every 5 years).

Even regular fulfilling of all the prescribed above maintenance operations may not completely prevent dirt accumulation in the air ducts which reduces the unit capacity.

Duct maintenance means regular cleaning or replacement.

### 5. Control unit maintenance (if necessary).

The control unit is positioned inside the unit casing.

To access the control unit, remove the mounting screws of the service panel of the unit and take it off.

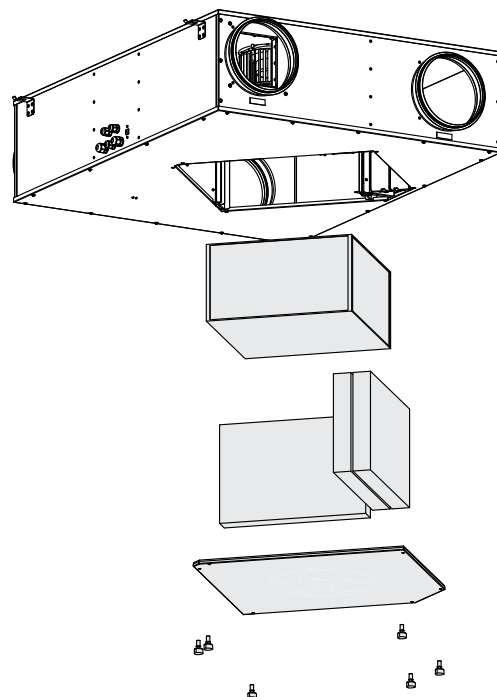

## TROUBLESHOOTING

Problem	Possible reasons	Troubleshooting
The fan(s) do(es) not get started.	The unit is disconnected from network.	Make sure the power supply line is connected correctly, otherwise troubleshoot a connection error.
Low air flow.	Filters, fans or the heat exchanger are soiled.	Clean or replace the filters. Clean the fans and the heat exchanger.
	The ventilation system is clogged or damaged.	Clean the ventilation system components. Replace the damaged components.
Noise, vibration	The fan impeller is soiled.	Clean the impellers.
	The fan or casing screw connection is loose.	Tighten the screw connection of the fans or the casing against stop.

## STORAGE AND TRANSPORTATION REGULATIONS

- Store the unit in the manufacturer's original packaging box in a dry closed ventilated premise with temperature range from +5 °C to + 40 °C and relative humidity up to 70 %.
- Storage environment must not contain aggressive vapors and chemical mixtures provoking corrosion, insulation, and sealing deformation.
- Use suitable hoist machinery for handling and storage operations to prevent possible damage to the unit.
- Follow the handling requirements applicable for the particular type of cargo.
- The unit can be carried in the original packaging by any mode of transport provided proper protection against precipitation and mechanical damage. The unit must be transported only in the working position.
- Avoid sharp blows, scratches, or rough handling during loading and unloading.
- Prior to the initial power-up after transportation at low temperatures, allow the unit to warm up at operating temperature for at least 3-4 hours.

## MANUFACTURER'S WARRANTY

The product is in compliance with EU norms and standards on low voltage guidelines and electromagnetic compatibility. We hereby declare that the product complies with the provisions of Electromagnetic Compatibility (EMC) Directive 2014/30/EU of the European Parliament and of the Council, Low Voltage Directive (LVD) 2014/35/EU of the European Parliament and of the Council and CE-marking Council Directive 93/68/EEC. This certificate is issued following test carried out on samples of the product referred to above.

The manufacturer hereby warrants normal operation of the unit for 24 months after the retail sale date provided the user's observance of the transportation, storage, installation, and operation regulations. Should any malfunctions occur in the course of the unit operation through the Manufacturer's fault during the guaranteed period of operation, the user is entitled to get all the faults eliminated by the manufacturer by means of warranty repair at the factory free of charge. The warranty repair includes work specific to elimination of faults in the unit operation to ensure its intended use by the user within the guaranteed period of operation. The faults are eliminated by means of replacement or repair of the unit components or a specific part of such unit component.

### The warranty repair does not include:

- routine technical maintenance
- unit installation/dismantling
- unit setup

To benefit from warranty repair, the user must provide the unit, the user's manual with the purchase date stamp, and the payment paperwork certifying the purchase. The unit model must comply with the one stated in the user's manual. Contact the Seller for warranty service.

### The manufacturer's warranty does not apply to the following cases:

- User's failure to submit the unit with the entire delivery package as stated in the user's manual including submission with missing component parts previously dismantled by the user.
- Mismatch of the unit model and the brand name with the information stated on the unit packaging and in the user's manual.
- User's failure to ensure timely technical maintenance of the unit.
- External damage to the unit casing (excluding external modifications as required for installation) and internal components caused by the user.
- Redesign or engineering changes to the unit.
- Replacement and use of any assemblies, parts and components not approved by the manufacturer.
- Unit misuse.
- Violation of the unit installation regulations by the user.
- Violation of the unit control regulations by the user.
- Unit connection to power mains with a voltage different from the one stated in the user's manual.
- Unit breakdown due to voltage surges in power mains.
- Discretionary repair of the unit by the user.
- Unit repair by any persons without the manufacturer's authorization.
- Expiration of the unit warranty period.
- Violation of the unit transportation regulations by the user.
- Violation of the unit storage regulations by the user.
- Wrongful actions against the unit committed by third parties.
- Unit breakdown due to circumstances of insuperable force (fire, flood, earthquake, war, hostilities of any kind, blockades).
- Missing seals if provided by the user's manual.
- Failure to submit the user's manual with the unit purchase date stamp.
- Missing payment paperwork certifying the unit purchase.



**FOLLOWING THE REGULATIONS STIPULATED HEREIN WILL ENSURE A LONG AND TROUBLE-FREE OPERATION OF THE UNIT.**



**USER'S WARRANTY CLAIMS SHALL BE SUBJECT TO REVIEW ONLY UPON PRESENTATION OF THE UNIT, THE PAYMENT DOCUMENT AND THE USER'S MANUAL WITH THE PURCHASE DATE STAMP.**

**CERTIFICATE OF ACCEPTANCE**

<b>Unit Type</b>	Heat and energy recovery air handling unit
<b>Model</b>	KOMFORT ERV EC DB _____ S14
<b>Serial Number</b>	
<b>Manufacture Date</b>	
<b>Quality Inspector's Stamp</b>	

**SELLER INFORMATION**

<b>Seller</b>	
<b>Address</b>	
<b>Phone Number</b>	
<b>E-mail</b>	
<b>Purchase Date</b>	
This is to certify acceptance of the complete unit delivery with the user's manual. The warranty terms are acknowledged and accepted.	
<b>Customer's Signature</b>	

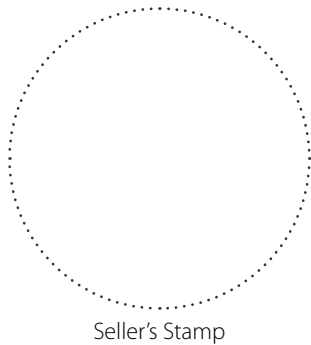

**INSTALLATION CERTIFICATE**

The KOMFORT ERV EC DB _____ S14 unit is installed pursuant to the requirements stated in the present user's manual.	
<b>Company name</b>	
<b>Address</b>	
<b>Phone Number</b>	
<b>Installation Technician's Full Name</b>	
<b>Installation Date:</b>	<b>Signature:</b>
The unit has been installed in accordance with the provisions of all the applicable local and national construction, electrical and technical codes and standards. The unit operates normally as intended by the manufacturer.	
<b>Signature:</b>	

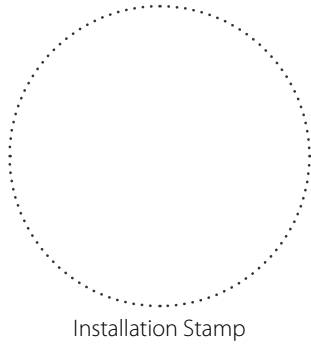

**WARRANTY CARD**

<b>Unit Type</b>	Heat and energy recovery air handling unit
<b>Model</b>	KOMFORT ERV EC DB _____ S14
<b>Serial Number</b>	
<b>Manufacture Date</b>	
<b>Purchase Date</b>	
<b>Warranty Period</b>	
<b>Seller</b>	

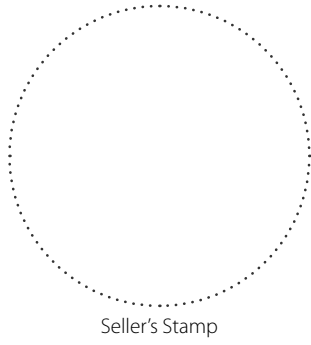



**BLAUBERG**  
*Ventilatoren*

