





AIR HANDLING UNITS

CONTENTS



Compact heat recovery air handling units

	KOMFORT Ultra EC S2 300	6
	KOMFORT Ultra EC L2 300	10
	KOMFORT Ultra S 250	14
	KOMFORT Ultra L 250	18
	KOMFORT Ultra D 105	22

Heat recovery air handling units in EPP casing

	KOMFORT EC S5(B) 270	26
	KOMFORT EC D5(B) 180	32

Heat recovery air handling units

	KOMFORT EC S(B)	38
	KOMFORT EC DB	50

Heat recovery air handling units

	KOMFORT ERV EC DB	56
	KOMFORT ERV D S20	60
	KOMFORT ERV D S3/S4	64
	KOMFORT EC DBE	68
	KOMFORT EC DBW	76
	KOMFORT EC LB(E)	86
	KOMFORT L	96
	KOMFORT LE	100
	KOMFORT LW	108

Air handling units with rotary heat exchanger

	KOMFORT Roto EC S(E)	116
	KOMFORT Roto EC S6(E)K 200	126
	KOMFORT Roto EC L(E)HP	132
	KOMFORT Roto EC LE/LW	144
	KOMFORT Roto EC D S21	154

Supply ventilation units

	BLAUBOX E PRO	162
	BLAUBOX ME PRO	168
	BLAUBOX MW PRO	174
	BLAUBOX DE PRO	182

Supply ventilation units

	BLAUBOX DW PRO	186
--	----------------	-----



Kitchen exhaust hood

	DAH 251-13	192
--	------------	-----



Module for Modbus connection

	PCOS004850	193
---	------------	-----



Heaters

	EVH	194
	ENH	196
	WKH	198

Coolers

	KWK	204
	KFK	212



Silencers

	SD	220
	SDF	222
	SD	224



Air dampers

	VK	226
	VKA	227
	VRV	228
	VRVS	229
	VK	230
	AVK	231



Air dampers

	SL	232
	VRVS	234

Flexible anti-vibration connectors

	EVA	235
	EVAF	236
	EVA	237

Clamps

	KZ	238
	KZH	239

Speed controllers

	SGR-3/1	240
--	---------	-----

Speed controllers



SGS E1 / SGS E2.5 241



CDP-2/5 (3/5) 242



CDT E1.8 243



CDT E/0-10 244



CDTE E1.8 245



CDTE E/0-10 246



CDT1 E 247

Control panels



S22 / S22 Wi-Fi 248



S25 249

Sensors



DPWQ30600 250



DPWC11200 252



DPWQ40200 254



CD-1 / CD-2 256



HR-S 257



FS2 258

Electric actuators



BELIMO CM230 / CM24 260



BELIMO TF230 / TF24 261



BELIMO LF230 / LF24 262

Condensate drainage



CP-2

264



SFK 20x32

265

Water mixing units



WMG

266

KOMFORT ULTRA EC S2 300

Compact heat recovery air handling units

Features

- Air handling units for efficient supply and exhaust ventilation in flats, houses, cottages and other buildings.
- The heat recovery technology is used to minimize ventilation heat losses.
- Control of air exchange for creating comfortable indoor microclimate.
- Compatible with round Ø 125 mm air ducts.



Air flow:
up to 300 m³/h
83 l/s



Heat recovery efficiency:
up to 79 %



Design

- The casing of **KOMFORT Ultra EC S2 300 ... white** is made of double-skinned white painted metal panels, internally filled with 20 mm mineral wool layer for heat- and sound-insulation.
- The spigots are located at the top of the unit and are rubber sealed for airtight connection to the air ducts.
- The hinged panel of the casing ensures easy access to the unit internals for service works including cleaning, filter replacement, etc.

Fans

- The unit is equipped with high-efficient external rotor EC motors and centrifugal impellers with forward curved blades.
- EC motors have the best power consumption to air flow ratio and meet the latest demands concerning energy saving and high-efficient ventilation.
- EC motors are featured with high performance, low noise level and totally controllable speed range.
- The impellers are dynamically balanced.

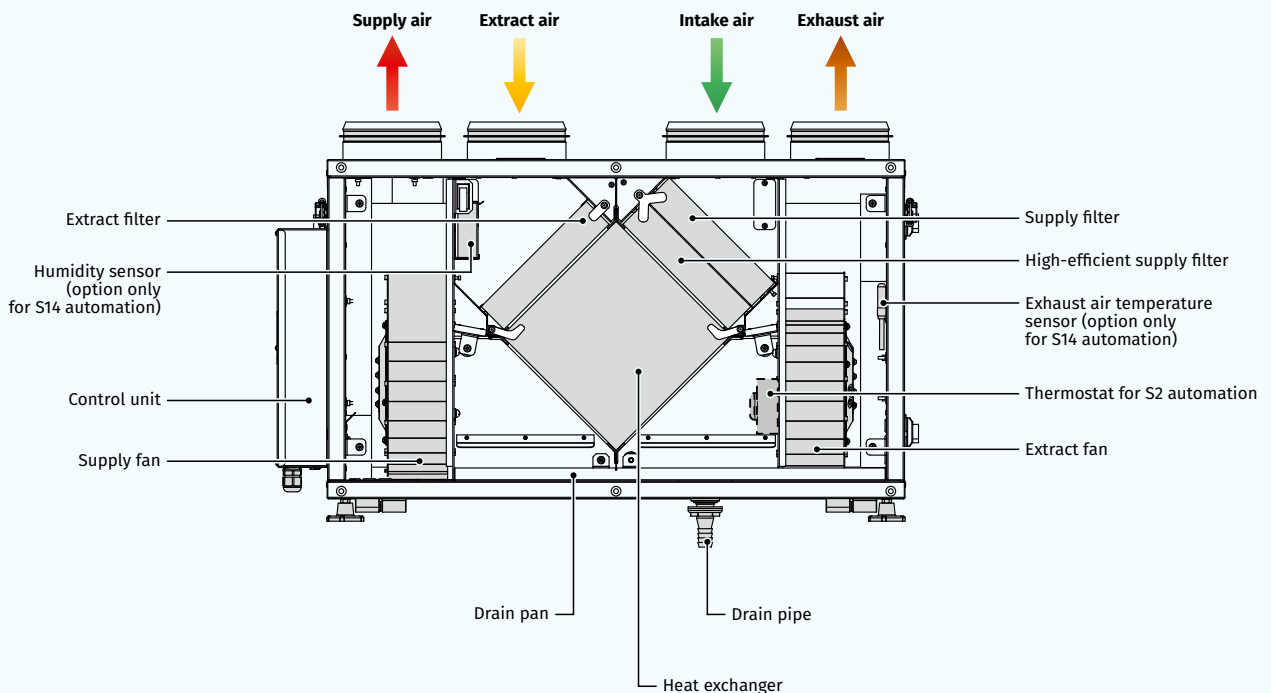

COMPACT HEAT RECOVERY AIR HANDLING UNITS

Heat recovery

o The **KOMFORT Ultra EC S2 300-H ... white** unit is equipped with a plate cross-flow polystyrene heat exchanger for heat recovery. The unit condensate is collected and drained to the drain pan under the heat exchanger.

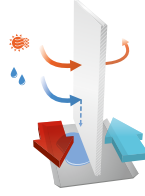

o The **KOMFORT Ultra EC S2 300-E ... white** unit is equipped with an enthalpy plate cross-flow heat exchanger for energy (heat and humidity) recovery. Due to humidity recovery condensate is not generated in the enthalpy heat exchanger.



- o The air flows are completely separated in the heat exchanger. Thus smells and contaminants are not transferred from the extract air to the supply air.
- o Heat recovery is based on heat and/or humidity transfer through the heat exchanger plates. In the cold season supply air is heated in the heat exchanger by transferring the heat energy of warm and humid extract air to the cold fresh air. Heat recovery minimizes ventilation heat losses and heating costs respectively.
- o In the warm season the heat exchanger performs reverse and intake air is cooled in the heat exchanger by the cool extract air. That reduces operation load on air conditioners and saves electricity.
- o When the indoor and outdoor temperature difference is insignificant, heat recovery is not reasonable. In this case the heat exchanger can be temporary replaced with a summer block for the warm season (available as a specially ordered accessory).

FREEZE PROTECTION

- o The integrated automatic freeze protection is used to prevent freezing of the heat exchanger in the cold season. The supply fan turns off according to the temperature sensor to get the heat exchanger warmed up with extract air. After that the supply fan turns on and the unit continues to run in the standard mode.

Air filtration

- o Two built-in G4 and F8 filters provide efficient supply air filtration.
- o The G4 filter is used for extract air filtration.

Control and automation

o The **KOMFORT Ultra EC S2 300-H(E) S2 white** unit is equipped with the CDT E/0-10 speed controller that is included in the delivery.



o The **KOMFORT Ultra EC S2 300-H(E) S14 white** units have an integrated control system with a wall-mounted control panel S14 with a LED indication.



The S14 control panel functions:

- Unit On/Off.
- Speed selection: Low, Medium or High.
- Activation of the summer ventilation mode: The supply fan stops and the extract fan continues its operation with no heat recovery.

- Alarm indication.
- Filter maintenance indication.

The KOMFORT Ultra EC S2 300-H(E) S14 white unit is equipped with a USB connector (Type B) and can be connected to a PC for configuring the advanced settings in a special software:

- Fan speed adjustment from 0 to 100 %. Each speed is individually adjusted for the supply and the extract fans.
- Operation control on feedback from the FS2 duct humidity sensor (to be ordered separately).
- Unit operation setting according to the external relay (to be ordered separately).
- Temperature setting for freeze protection system activation.
- Control and operation adjustment of the filter maintenance timer.
- External control unit and humidity level control.
- Software version upgrading.

Mounting

- o The units can be fixed to the wall or mounted on the floor using the mounting brackets. The **KOMFORT Ultra EC S2 300-E ... white** unit is also suitable for ceiling mounting.
- o The **KOMFORT Ultra EC S2 300-H ... white** unit mounting position must provide condensate collection and drainage.
- o While mounting provide free access to the service panel for filter replacement and servicing.
- o Due to universal casing design both left and right mounting is possible. It requires swapping the service and the back panel.

Designation key

Series	Unit type	Motor type	Spigot modification	Insulation	Rated air flow [m³/h]	Heat exchanger type	Control	Casing
KOMFORT	Ultra: compact unit	EC: electronically commutated motor	S: vertical spigot orientation	2: insulation 20 mm	300	H: heat recovery E: energy recovery	S2: CDT E/0-10 speed controller S14: sensor control panel with LED indication	white: painted steel

Overall dimensions [mm]

Model	D	B	H	H1	L	L1
KOMFORT Ultra EC S2 300-H(E) S2 white	125	300	443	490	713	43
KOMFORT Ultra EC S2 300-H(E) S14 white	125	300	443	490	713	63

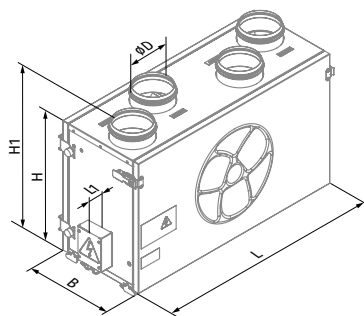

KOMFORT Ultra EC S2 300-H(E) S2 white

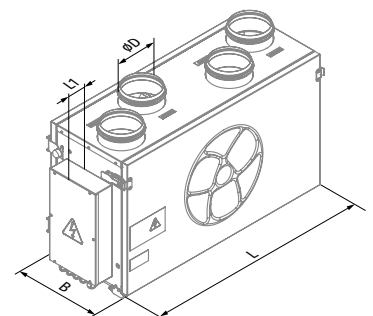

KOMFORT Ultra EC S2 300-H(E) S14 white

Technical data

Parameters	KOMFORT Ultra EC S2 300-H S2 white KOMFORT Ultra EC S2 300-H S14 white	KOMFORT Ultra EC S2 300-E S2 white KOMFORT Ultra EC S2 300-E S14 white
Voltage [V / 50 (60) Hz]	1 ~ 230	1 ~ 230
Power [W]	165	165
Current [A]	1.3	1.3
Maximum air flow [m ³ /h (l/s)]	300 (83)	300 (83)
RPM [min ⁻¹]	2050	2050
Sound pressure level at 3 m [dBA]	33	33
Transported air temperature [°C]	-25...+40	-25...+40
Insulation	20 mm mineral wool	20 mm mineral wool
Extract filter	G4	G4
Supply filter	G4, F8	G4, F8
Connected air duct diameter [mm]	125	125
Weight [kg]	32	28
Heat recovery efficiency [%]*	55-79	51-73
Humidity recovery efficiency [%]	-	26-45
Heat exchanger type	cross-flow	cross-flow
Heat exchanger material	polysterene	enthalpy
SEC class for S2 automation	B	C
SEC class for S14 automation	A	A
ErP	2016, 2018	2016, 2018

*Heat recovery efficiency is specified in compliance with the EN 13141-7.

Sound power level, A-weighted	Total	Octave frequency band [Hz]								LpA 3 m	LpA 1 m
		63	125	250	500	1000	2000	4000	8000		
L _{WA} to supply inlet [dBA]	56	48	43	53	44	44	40	26	24		
L _{WA} to supply outlet [dBA]	71	53	53	68	65	60	59	52	51		
L _{WA} to exhaust inlet [dBA]	57	43	51	52	52	45	37	26	21		
L _{WA} to exhaust outlet [dBA]	72	53	60	66	67	61	62	55	48		
L _{WA} to environment [dBA]	53	33	44	47	50	44	38	29	24	33	43







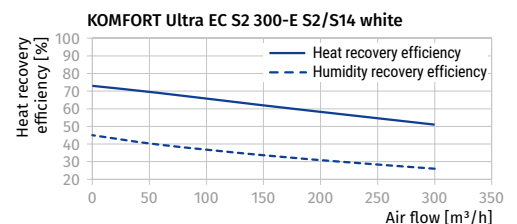
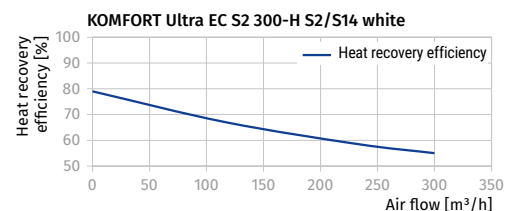
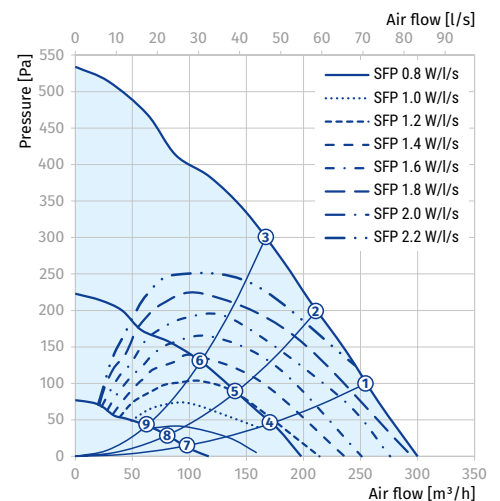



Data provided for point 1 of the air flow diagram

Total power. Total sound pressure level.

Point	Total power of the unit [W]	Sound pressure level at 3 m (1 m) [dBA]
1	150	33 (43)
2	138	33 (43)
3	121	32 (42)
4	52	31 (41)
5	48	28 (38)
6	41	27 (37)
7	17	27 (37)
8	16	23 (33)
9	14	23 (33)



Accessories

		KOMFORT Ultra EC S2 300-H S2 white KOMFORT Ultra EC S2 300-E S2 white	KOMFORT Ultra EC S2 300-H S14 white KOMFORT Ultra EC S2 300-E S14 white
G4 panel filter		FP 240x184x40 G4	FP 240x184x40 G4
F8 panel filter		FP 240x184x40 F8	FP 240x184x40 F8
Humidity sensor		-	FS2
CO ₂ sensor with indication		-	CD-1
CO ₂ sensor		-	CD-2
Humidity sensor		-	HR-S
Silencer		SD 125	SD 125
Backdraft air damper		VRV 125	VRV 125
Air damper		-	VKA 125
Electric actuator		-	LF230
Summer block		SB C4 200/240	SB C4 200/240

KOMFORT ULTRA EC L2 300

Compact heat recovery air handling units

Features

- Air handling units for efficient supply and exhaust ventilation in flats, houses, cottages and other buildings.
- The heat recovery technology is used to minimize ventilation heat losses.
- Control of air exchange for creating comfortable indoor microclimate.
- Compatible with round Ø 125 mm air ducts.



Air flow:
up to 300 m³/h
83 l/s



Heat recovery efficiency:
up to 79 %



Design

- The casing of **KOMFORT Ultra EC L2 300 ... white** is made of double-skinned white painted metal panels, internally filled with 20 mm mineral wool layer for heat- and sound-insulation.
- The spigots are located at the sides of the unit and are equipped with rubber seals for airtight connection to the air ducts.
- The hinged panel of the casing ensures easy access to the unit internals for service works including cleaning, filter replacement, etc.

Fans

- The unit is equipped with high-efficient external rotor EC motors and centrifugal impellers with forward curved blades.
- EC motors have the best power consumption to air flow ratio and meet the latest demands concerning energy saving and high-efficient ventilation.
- EC motors are featured with high performance, low noise level and totally controllable speed range.
- The impellers are dynamically balanced.

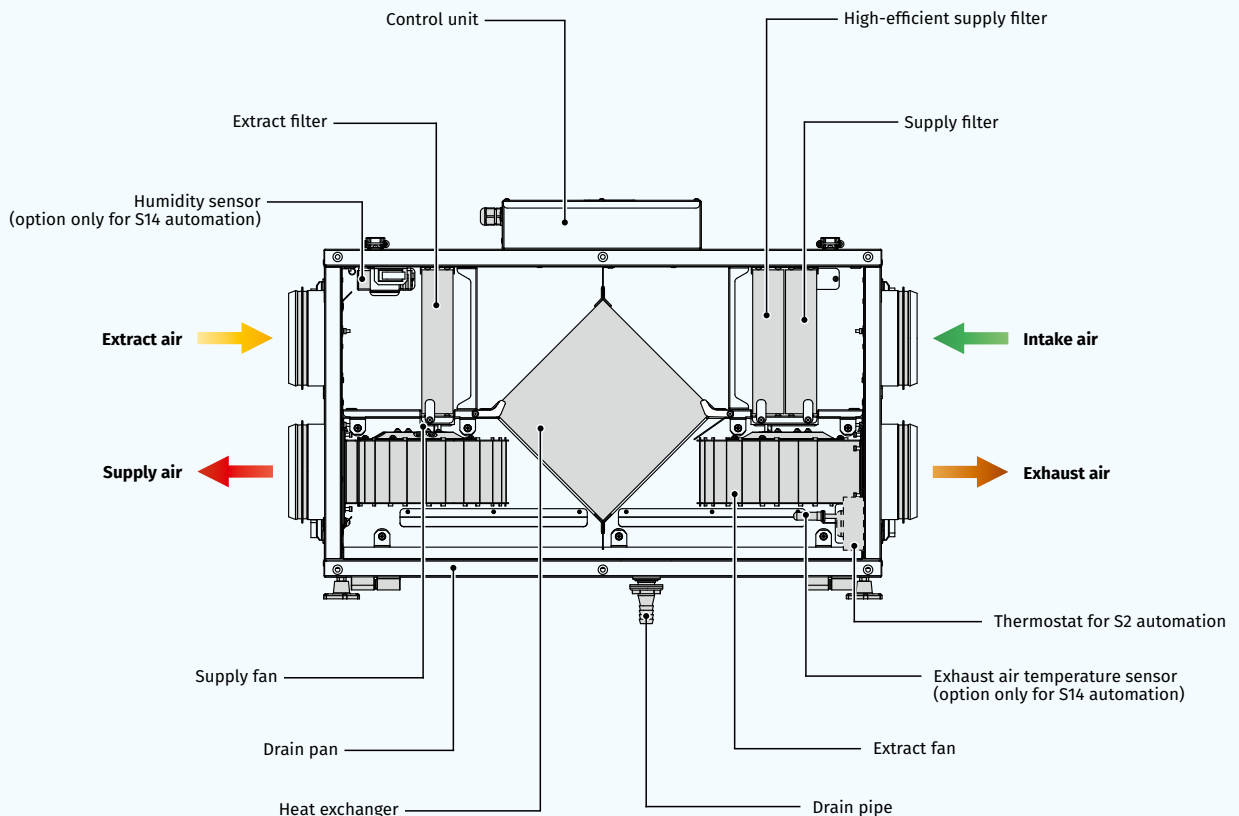

Heat recovery

- The **KOMFORT Ultra EC L2 300-H ... white** unit is equipped with a plate cross-flow polystyrene heat exchanger for heat recovery. The unit condensate is collected and drained to the drain pan under the heat exchanger.
- The **KOMFORT Ultra EC L2 300-E ... white** unit is equipped with an enthalpy plate cross-flow heat exchanger for energy (heat and humidity) recovery. Due to humidity recovery condensate is not generated in the enthalpy heat exchanger.

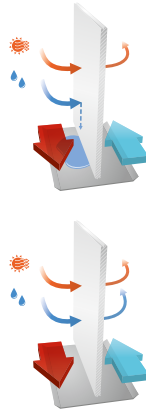

Control and automation

- The **KOMFORT Ultra EC L2 300-H(E) S2 white** unit is equipped with the CDT E/0-10 speed controller that is included in the delivery.
- The **KOMFORT Ultra EC L2 300-H(E) S14 white** units have an integrated control system with a wall-mounted control panel S14 with a LED indication.



The S14 control panel functions:

- Unit On/Off.
- Speed selection: Low, Medium or High.
- Activation of the summer ventilation mode: The supply fan stops and the extract fan continues its operation with no heat recovery.
- Alarm indication.
- Filter maintenance indication.

The KOMFORT Ultra EC L2 300-H(E) S14 white unit is equipped with a USB connector (Type B) and can be connected to a PC for configuring the advanced settings in a special software:

- Fan speed adjustment from 0 to 100 %. Each speed is individually adjusted for the supply and the extract fans
- Operation control on feedback from the FS2 duct humidity sensor (to be ordered separately)
- Unit operation setting according to the external control unit (to be ordered separately)
- Temperature setting for freeze protection system activation
- Control and operation adjustment of the filter maintenance timer
- External relay status and humidity level control
- Software version upgrading

Mounting

- The units can be fixed to the wall or mounted on the floor using the mounting brackets. The **KOMFORT Ultra EC L2 300-E ... white** unit is also suitable for ceiling mounting.
- The **KOMFORT Ultra EC L2 300-H ... white** unit mounting position must provide condensate collection and drainage.
- While mounting provide free access to the service panel for filter replacement and servicing.
- Due to universal casing design both left and right mounting is possible. It requires swapping the service and the back panel.

- The air flows are completely separated in the heat exchanger. Thus smells and contaminants are not transferred from the extract air to the supply air.
- Heat recovery is based on heat and/or humidity transfer through the heat exchanger plates. In the cold season supply air is heated in the heat exchanger by transferring the heat energy of warm and humid extract air to the cold fresh air. Heat recovery minimizes ventilation heat losses and heating costs respectively.
- In the warm season the heat exchanger performs reverse and intake air is cooled in the heat exchanger by the cool extract air. That reduces operation load on air conditioners and saves electricity.
- When the indoor and outdoor temperature difference is insignificant, heat recovery is not reasonable. In this case the heat exchanger can be temporary replaced with a summer block for the warm season (available as a specially ordered accessory).

FREEZE PROTECTION

- The integrated automatic freeze protection is used to prevent freezing of the heat exchanger in the cold season. The supply fan turns off according to the temperature sensor to get the heat exchanger warmed up with extract air. After that the supply fan turns on and the unit continues to run in the standard mode.

Air filtration

- Two built-in G4 and F8 filters provide efficient supply air filtration.
- The G4 filter is used for extract air filtration.

Designation key

Series	Unit type	Motor type	Spigot modification	Insulation	Rated air flow [m³/h]	Heat exchanger type	Control	Casing
KOMFORT	Ultra: compact unit	EC: electronically commutated motor	L: horizontal spigot orientation	2: Insulation 20 mm	300	- H: heat recovery E: energy recovery	S2: CDT E/0-10 speed controller S14: sensor control panel with LED indication	white: painted steel

Overall dimensions [mm]

Model	D	B	H	H1	L	L1
KOMFORT Ultra EC L2 300-H(E) S2 white	125	300	443	43	713	810
KOMFORT Ultra EC L2 300-H(E) S14 white	125	300	443	63	713	810

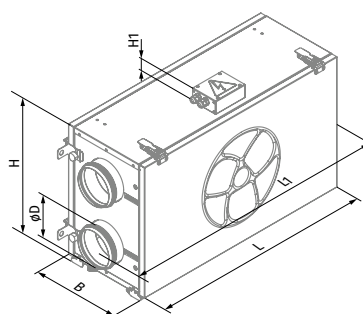

KOMFORT Ultra EC L2 300-H(E) S2 white

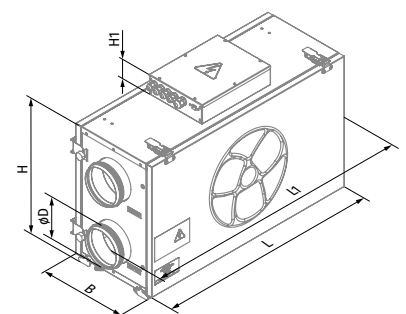

KOMFORT Ultra EC L2 300-H(E) S14 white

Technical data

Parameters	KOMFORT Ultra EC L2 300-H S2 white KOMFORT Ultra EC L2 300-H S14 white	KOMFORT Ultra EC L2 300-E S2 white KOMFORT Ultra EC L2 300-E S14 white
Voltage [V / 50 (60) Hz]	1 ~ 230	1 ~ 230
Power [W]	165	165
Current [A]	1.3	1.3
Maximum air flow [m ³ /h (l/s)]	300 (83)	300 (83)
RPM [min ⁻¹]	2050	2050
Sound pressure level at 3 m [dBA]	33	33
Transported air temperature [°C]	-25...+40	-25...+40
Insulation	20 mm mineral wool	20 mm mineral wool
Extract filter	G4	G4
Supply filter	G4, F8	G4, F8
Connected air duct diameter [mm]	125	125
Weight [kg]	32	28
Heat recovery efficiency [%]*	55-79	51-73
Humidity recovery efficiency [%]	-	26-45
Heat exchanger type	cross-flow	cross-flow
Heat exchanger material	polysterene	enthalpy
SEC class for S2 automation	B	C
SEC class for S14 automation	A	A
ErP	2016, 2018	2016, 2018

*Heat recovery efficiency is specified in compliance with the EN 13141-7.

Sound power level, A-weighted	Total	Octave frequency band [Hz]								LpA 3 m	LpA 1 m
		63	125	250	500	1000	2000	4000	8000		
L _{WA} to supply inlet [dBA]	56	48	43	53	44	44	40	26	24		
L _{WA} to supply outlet [dBA]	71	53	53	68	65	60	59	52	51		
L _{WA} to exhaust inlet [dBA]	57	43	51	52	52	45	37	26	21		
L _{WA} to exhaust outlet [dBA]	72	53	60	66	67	61	62	55	48		
L _{WA} to environment [dBA]	53	33	44	47	50	44	38	29	24	33	43







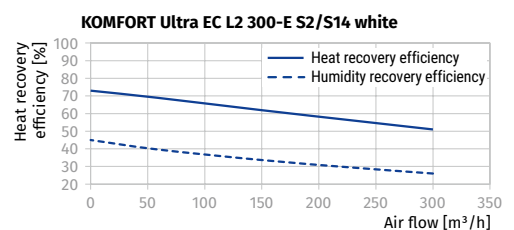
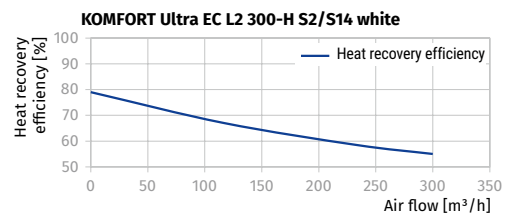
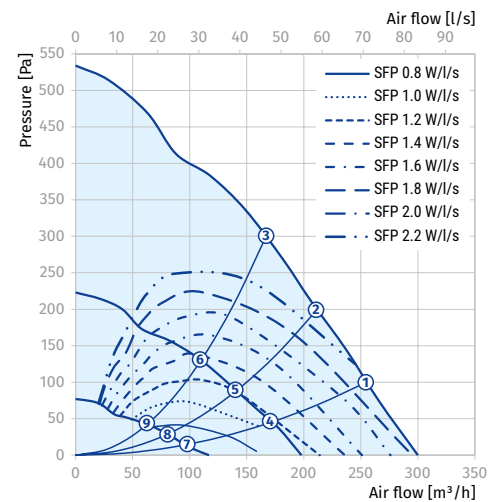



Data provided for point 1 of the air flow diagram

Total power. Total sound pressure level.

Point	Total power of the unit [W]	Sound pressure level at 3 m (1 m) [dBA]
1	150	33 (43)
2	138	33 (43)
3	121	32 (42)
4	52	31 (41)
5	48	28 (38)
6	41	27 (37)
7	17	27 (37)
8	16	23 (33)
9	14	23 (33)



Accessories

		KOMFORT Ultra EC L2 300-H S2 white KOMFORT Ultra EC L2 300-E S2 white	KOMFORT Ultra EC L2 300-H S14 white KOMFORT Ultra EC L2 300-E S14 white
G4 panel filter		FP 240x184x40 G4	FP 240x184x40 G4
F8 panel filter		FP 240x184x40 F8	FP 240x184x40 F8
Humidity sensor		-	FS2
CO ₂ sensor with indication		-	CD-1
CO ₂ sensor		-	CD-2
Humidity sensor		-	HR-S
Silencer		SD 125	SD 125
Backdraft air damper		VRV 125	VRV 125
Air damper		-	VKA 125
Electric actuator		-	LF230
Summer block		SB C4 200/240	SB C4 200/240

KOMFORT ULTRA S 250

Compact heat recovery air handling units

Features

- Air handling units for efficient supply and exhaust ventilation in flats, houses, cottages and other buildings.
- Heat and humidity recovery reduces ventilation heat losses in the cold season and the load on the air conditioners in the hot season.
- Control of air exchange for creating comfortable indoor microclimate.
- Compatible with round Ø 125 mm air ducts.



Air flow:
up to 250 m³/h
69 l/s



Heat recovery efficiency:
up to 78 %



Design

- The casing of **KOMFORT Ultra S 250-H(E) S12** is made of double-skinned aluzinc panels, internally filled with 20 mm mineral wool layer for heat- and sound-insulation.
- The casing of **KOMFORT Ultra S 250-H(E) S12 white** is made of double-skinned white painted metal panels, internally filled with 20 mm mineral wool layer for heat and sound insulation.
- The spigots are located at the top of the unit and are rubber sealed for airtight connection to the air ducts.
- The hinged panel of the casing ensures easy access to the unit internals for service works including cleaning, filter replacement, etc.

Fans

- Asynchronous external rotor motors and centrifugal impellers with backward curved blades are used for air supply and exhaust.
- Integrated motor overheating protection with automatic restart.
- Dynamically balanced impellers.
- Equipped with ball bearings for longer service life.
- Reliable and quiet operation.

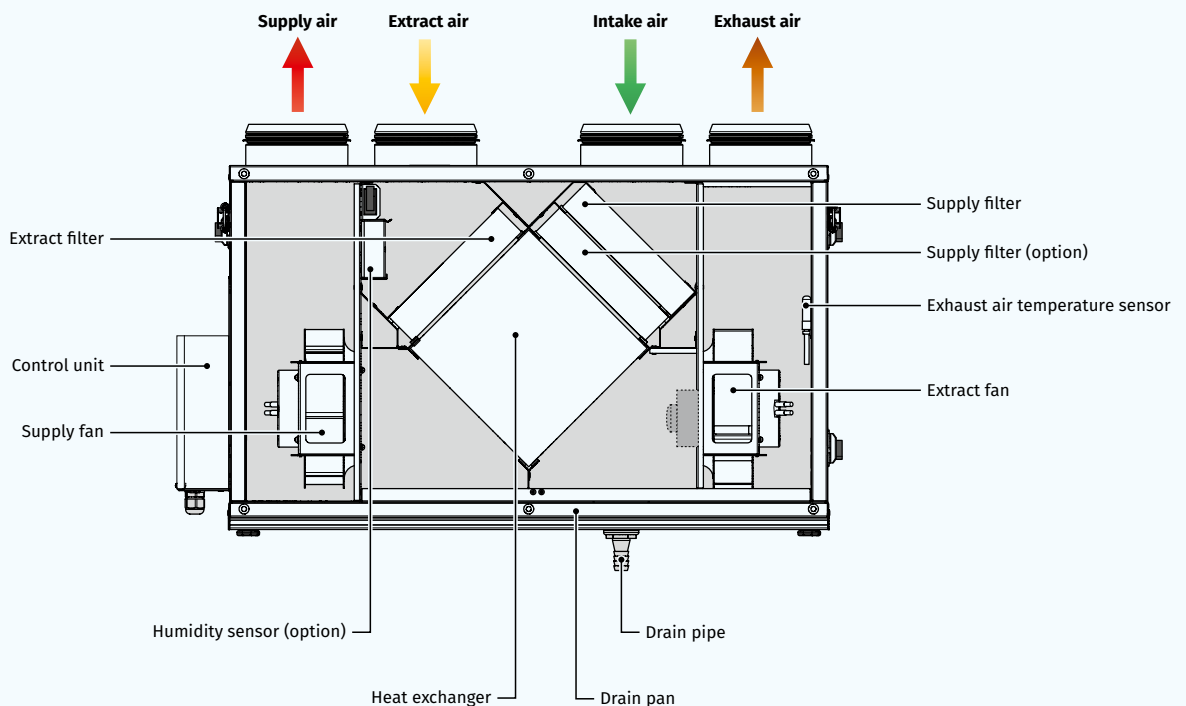

COMPACT HEAT RECOVERY AIR HANDLING UNITS

Heat recovery

The **KOMFORT Ultra S 250-H S12 (white)** unit is equipped with a plate cross-flow polystyrene heat exchanger for heat recovery. The unit condensate is collected and drained to the drain pan under the heat exchanger.

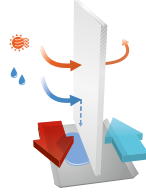

The **KOMFORT Ultra S 250-E S12 (white)** unit is equipped with an enthalpy plate cross-flow heat exchanger for energy (heat and humidity) recovery. Due to humidity recovery condensate is not generated in the enthalpy heat exchanger.



- The air flows are completely separated in the heat exchanger. Thus smells and contaminants are not transferred from the extract air to the supply air.
- Heat recovery is based on heat and/or humidity transfer through the heat exchanger plates. In the cold season supply air is heated in the heat exchanger by transferring the heat energy of warm and humid extract air to the cold fresh air. Heat recovery minimizes ventilation heat losses and heating costs respectively.
- In the warm season the heat exchanger performs reverse and intake air is cooled in the heat exchanger by the cool extract air. That reduces operation load on air conditioners and saves electricity.
- When the indoor and outdoor temperature difference is insignificant, heat recovery is not reasonable. In this case the heat exchanger can be temporary replaced with a summer block for the warm season (available as a specially ordered accessory).

FREEZE PROTECTION

- The integrated automatic freeze protection is used to prevent freezing of the heat exchanger in the cold season. The supply fan turns off according to the temperature sensor to get the heat exchanger warmed up with extract air. After that the supply fan turns on and the unit continues to run in the standard mode.

Designation key

Series	Unit type	Spigot modification	Rated air flow [m³/h]	Heat exchanger type	Control	Casing
KOMFORT	Ultra: compact unit	S: vertical spigot orientation	250	- H: heat recovery E: energy recovery	S12: speed controller SGS E1	-: aluzinc white: white-painted steel

Overall dimensions [mm]

Model	D	B	H	H1	L	L1
KOMFORT Ultra S 250-H(E) S12 (white)	125	300	443	490	713	43

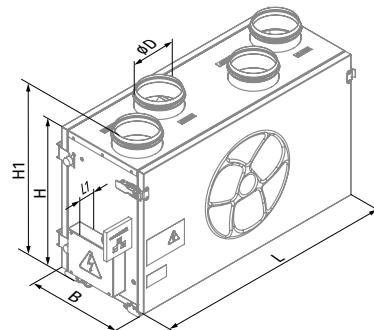

Air filtration

- The built-in G4 supply filter and G4 extract filter provide air filtration.
- The F8 supply filter (specially ordered accessory) may be used for efficient supply air filtration.

Control and automation

- Smooth motor speed control from 0 up to 100 % by means of the thyristor speed controller SGS E1 (included in the delivery).

Mounting

- The units can be fixed to the wall or mounted on the floor using the mounting brackets. The **KOMFORT Ultra S 250-E S12 (white)** unit is also suitable for ceiling mounting.
- While mounting provide free access to the service panel for filter replacement and servicing.
- The **KOMFORT Ultra S 250-H S12 (white)** unit mounting position must provide condensate collection and drainage.
- Due to universal casing design both left and right mounting is possible. It requires swapping the service and the back panel.

Technical data

Parameters	KOMFORT Ultra S 250-H S12 KOMFORT Ultra S 250-H S12 white	KOMFORT Ultra S 250-E S12 KOMFORT Ultra S 250-E S12 white
Voltage [V / 50 (60) Hz]	1 ~ 230	1 ~ 230
Power [W]	148	148
Current [A]	0.78	0.78
Maximum air flow [m ³ /h (l/s)]	250 (69)	250 (69)
RPM [min ⁻¹]	2700	2700
Sound pressure level at 3 m [dBA]	28-47	28-47
Transported air temperature [°C]	-25...+40	-25...+40
Insulation	20 mm mineral wool	20 mm mineral wool
Extract filter	G4	G4
Supply filter	G4 (option: F8 PM2.5 > 81 %)	G4 (option: F8 PM2.5 > 81 %)
Connected air duct diameter [mm]	125	125
Heat recovery efficiency [%]	55-78	52-73
Humidity recovery efficiency [%]	-	27-45
Heat exchanger type	cross-flow	cross-flow
Heat exchanger material	polyesterene	enthalpy
SEC class	E	E
ErP	2016	2016

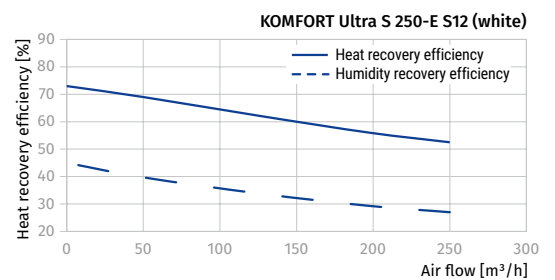
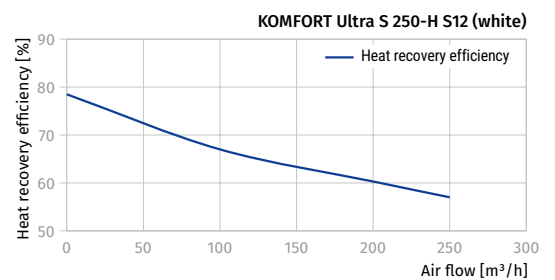
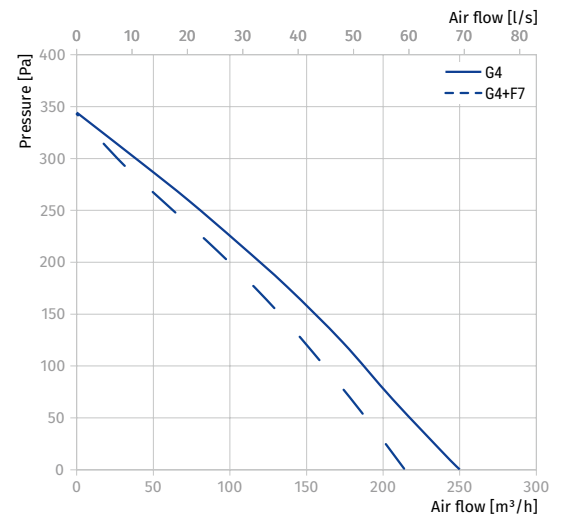

Accessories

		KOMFORT Ultra S 250-H S12 KOMFORT Ultra S 250-H S12 white	KOMFORT Ultra S 250-E S12 KOMFORT Ultra S 250-E S12 white
G4 panel filter		FP 240x184x40 G4	FP 240x184x40 G4
F8 panel filter		FP 240x184x40 F8	FP 240x184x40 F8
Silencer		SD 125	SD 125
Backdraft air damper		VRV 125	VRV 125
Air damper		VK 125	VK 125
Summer block		SB C4 200/240	SB C4 200/240

KOMFORT ULTRA L 250

Compact heat recovery air handling units

Features

- Air handling units for efficient supply and exhaust ventilation in flats, houses, cottages and other buildings.
- Heat and humidity recovery reduces ventilation heat losses in the cold season and the load on the air conditioners in the hot season.
- Heat recovery minimises ventilation heat losses.
- Control of air exchange for creating comfortable indoor microclimate.
- Compatible with round Ø 125 mm air ducts.



Air flow:
up to 250 m³/h
69 l/s



Heat recovery efficiency:
up to 78 %



Design

- The casing of **KOMFORT Ultra L 250 S12-H(E)** is made of double-skinned aluzinc panels, internally filled with 20 mm mineral wool layer for heat and sound insulation.
- The casing of **KOMFORT Ultra L 250-H(E) S12 white** is made of double-skinned white painted metal panels, internally filled with 20 mm mineral wool layer for heat and sound insulation.
- The spigots are located at the side of the unit and are rubber sealed for airtight connection to the air ducts.
- The hinged panel of the casing ensures easy access to the unit internals for service works including cleaning, filter replacement, etc.

Fans

- Asynchronous external rotor motors and centrifugal impellers with backward curved blades are used for air supply and exhaust.
- Integrated motor overheating protection with automatic restart.
- Dynamically balanced impellers.
- Equipped with ball bearings for longer service life.
- Reliable and quiet operation.

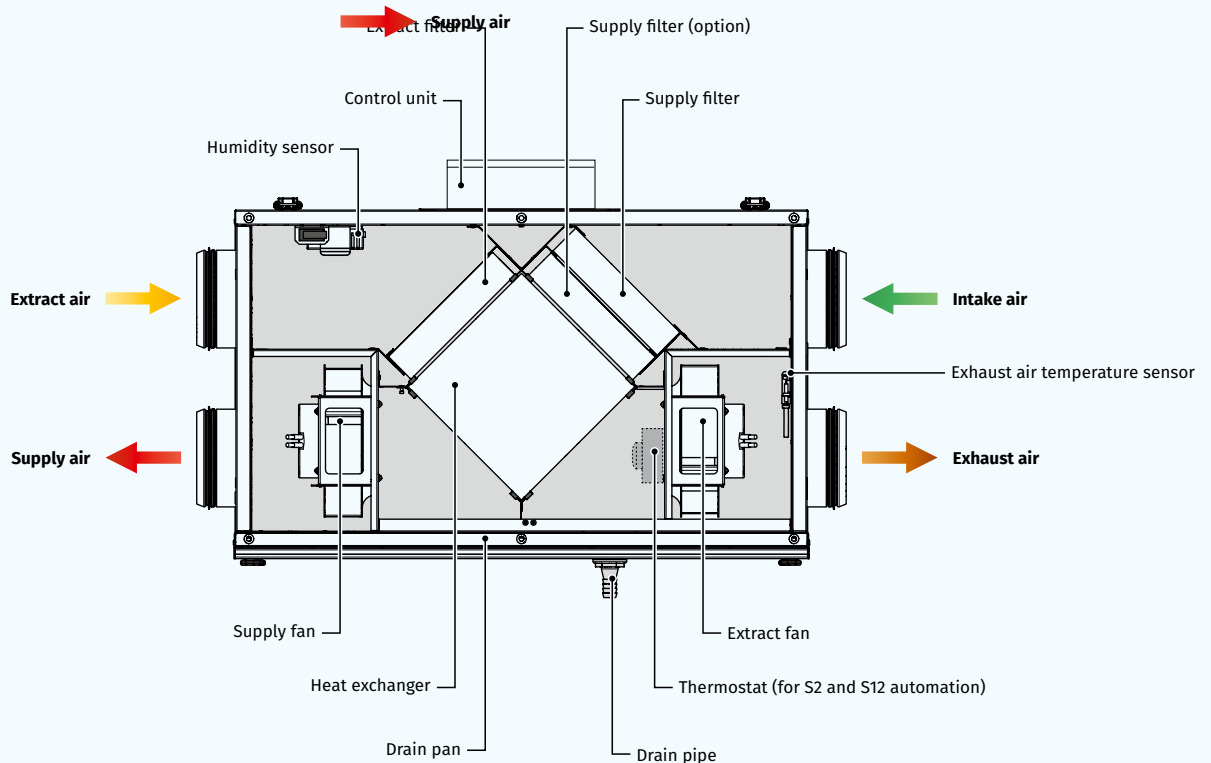

Heat recovery

o The **KOMFORT Ultra L 250-H S12 (white)** unit is equipped with a plate cross-flow polystyrene heat exchanger for heat recovery. The unit condensate is collected and drained to the drain pan under the heat exchanger.

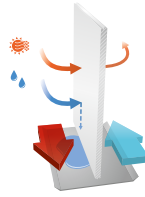

o The **KOMFORT Ultra L 250-E S12 (white)** unit is equipped with an enthalpy plate cross-flow heat exchanger for energy (heat and humidity) recovery. Due to humidity recovery condensate is not generated in the enthalpy heat exchanger.



- o The air flows are completely separated in the heat exchanger. Thus smells and contaminants are not transferred from the extract air to the supply air.
- o Heat recovery is based on heat and/or humidity transfer through the heat exchanger plates. In the cold season supply air is heated in the heat exchanger by transferring the heat energy of warm and humid extract air to the cold fresh air. Heat recovery minimizes ventilation heat losses and heating costs respectively.
- o In the warm season the heat exchanger performs reverse and intake air is cooled in the heat exchanger by the cool extract air. That reduces operation load on air conditioners and saves electricity.
- o When the indoor and outdoor temperature difference is insignificant, heat recovery is not reasonable. In this case the heat exchanger can be temporary replaced with a summer block for the warm season (available as a specially ordered accessory).

FREEZE PROTECTION

- o The integrated automatic freeze protection is used to prevent freezing of the heat exchanger in the cold season. The supply fan turns off according to the temperature sensor to get the heat exchanger warmed up with extract air. After that the supply fan turns on and the unit continues to run in the standard mode.

Designation key

Series	Unit type	Spigot modification	Rated air flow [m³/h]	Heat exchanger type	Control	Casing
KOMFORT	Ultra: compact unit	L: horizontal spigot orientation	250	- H: heat recovery E: energy recovery	S12: speed controller SGS E1	- : aluzinc white: white-painted steel

Overall dimensions [mm]

Model	D	B	H	H1	L	L1
KOMFORT Ultra L 250-H(E) S12 (white)	125	300	443	43	713	810

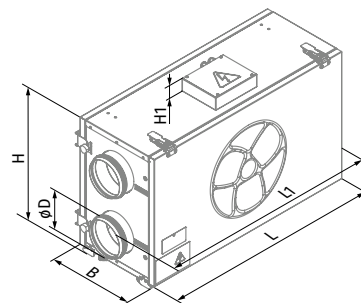

Air filtration

- o The built-in G4 supply filter and G4 extract filter provide air filtration.
- o The F8 supply filter (specially ordered accessory) may be used for efficient supply air filtration.

Control and automation

- o Smooth motor speed control from 0 up to 100 % by means of the thyristor speed controller SGS E1 (included in the delivery).

Mounting

- o The units can be fixed to the wall or mounted on the floor using the mounting brackets. The **KOMFORT Ultra L 250-E S12 (white)** unit is also suitable for ceiling mounting.
- o The **KOMFORT Ultra L 250-H S12 (white)** unit mounting position must provide condensate collection and drainage.
- o While mounting provide free access to the service panel for filter replacement and servicing.
- o Due to universal casing design both left and right mounting is possible. It requires swapping the service and the back panel.

Technical data

Parameters	KOMFORT Ultra L 250-H S12 KOMFORT Ultra L 250-H S12 white	KOMFORT Ultra L 250-E S12 KOMFORT Ultra L 250-E S12 white
Voltage [V / 50 (60) Hz]	1 ~ 230	1 ~ 230
Power [W]	148	148
Current [A]	0.78	0.78
Maximum air flow [m³/h (l/s)]	250 (69)	250 (69)
RPM [min ⁻¹]	2700	2700
Sound pressure level at 3 m [dBA]	28-47	28-47
Transported air temperature [°C]	-25...+40	-25...+40
Insulation	20 mm mineral wool	20 mm mineral wool
Extract filter	G4	G4
Supply filter	G4 (option: F8 PM2.5 > 81 %)	G4 (option: F8 PM2.5 > 81 %)
Connected air duct diameter [mm]	125	125
Heat recovery efficiency [%]	55-78	52-73
Humidity recovery efficiency [%]	-	27-45
Heat exchanger type	cross-flow	cross-flow
Heat exchanger material	polyesterene	enthalpy
SEC class	E	E
ErP	2016	2016

COMPACT HEAT RECOVERY AIR HANDLING UNITS

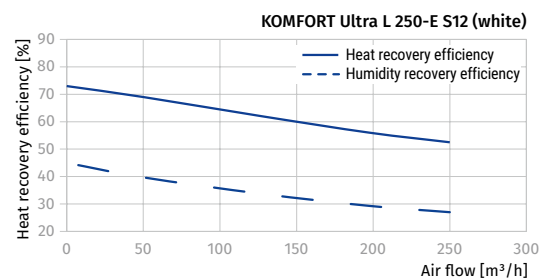
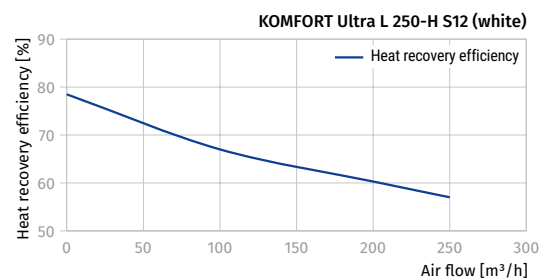
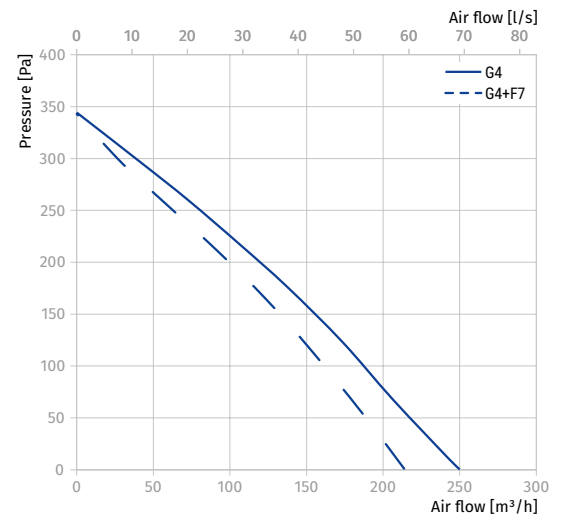

Accessories

		KOMFORT Ultra L 250-H S12 KOMFORT Ultra L 250-H S12 white	KOMFORT Ultra L 250-E S12 KOMFORT Ultra L 250-E S12 white
G4 panel filter		FP 240x184x40 G4	FP 240x184x40 G4
F8 panel filter		FP 240x184x40 F8	FP 240x184x40 F8
Silencer		SD 125	SD 125
Backdraft air damper		VRV 125	VRV 125
Air damper		VK 125	VK 125
Summer block		SB C4 200/240	SB C4 200/240

KOMFORT ULTRA D 105

Single room heat recovery air handling units

Features

- Air handling units for efficient supply and exhaust ventilation in flats, houses, cottages and other buildings.
- Heat recovery minimises ventilation heat losses.
- Controllable air exchange for creating the best suitable indoor microclimate.
- Compatible with round Ø 125 mm air ducts.



Air flow:
up to 106 m³/h
29 l/s



Heat recovery efficiency:
up to 76 %



Design

- The compact casing is made of double-skinned aluzinc panels, internally filled with 15 mm PE foam film layer for heat and sound insulation.
- The casing has mounting angles for easy installation.
- The spigots for connection to the air ducts are located at the side of the unit and are rubber sealed for airtight connection to the air ducts.
- The supply and exhaust spigots are equipped with backdraft dampers.
- The hinged side panel of the casing ensures easy access to the internals for cleaning and other maintenance operations.

Fans

- Asynchronous motors are used for air supply and exhaust.
- Centrifugal impeller with forward curved blades ensures high pressure and low noise level.
- Integrated overheating protection.
- Dynamically balanced impellers.
- Equipped with ball bearings for longer service life.

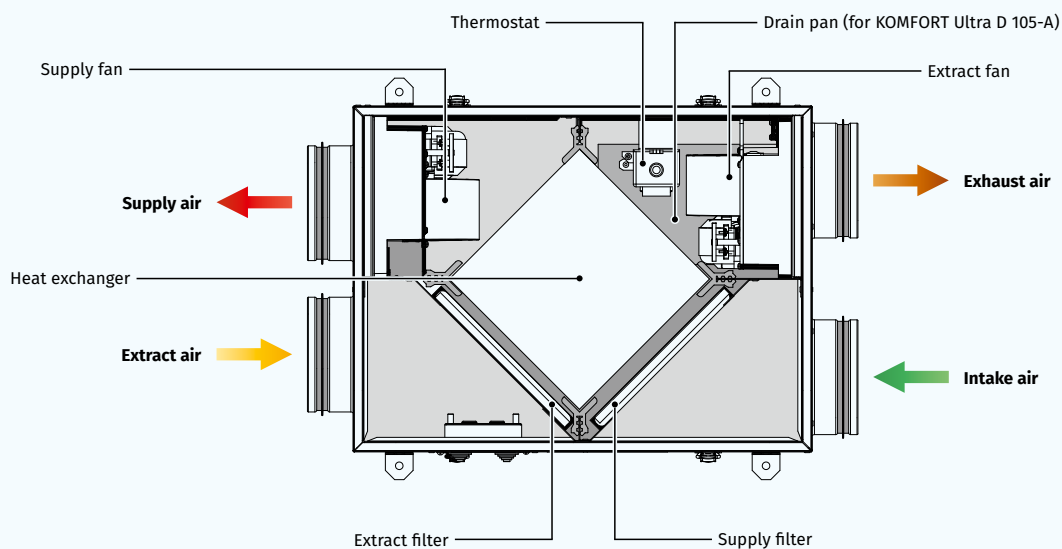

COMPACT HEAT RECOVERY AIR HANDLING UNITS

Heat recovery

- The **KOMFORT Ultra D 105-A** unit is equipped with a plate cross-flow polystyrene heat exchanger for heat recovery. The unit condensate is collected and drained to the drain pan under the heat exchanger.
- The **KOMFORT Ultra D 105** unit is equipped with an enthalpy plate cross-flow heat exchanger for energy (heat and humidity) recovery. Due to humidity recovery condensate is not generated in the enthalpy heat exchanger.
- The air flows are completely separated in the heat exchanger. Thus smells and contaminants are not transferred from the extract air to the supply air.
- Heat recovery is based on heat and/or humidity transfer through the heat exchanger plates. In the cold season supply air is heated in the heat exchanger by transferring the heat energy of warm and humid extract air to the cold fresh air. Heat recovery minimizes ventilation heat losses and heating costs respectively.
- In the warm season the heat exchanger performs reverse and intake air is cooled in the heat exchanger by the cool extract air. That reduces operation load on air conditioners and saves electricity.
- When the indoor and outdoor temperature difference is insignificant, heat recovery is not reasonable. In this case the heat exchanger can be temporary replaced with a summer block for the warm season (available as a specially ordered accessory).



Air filtration

- The built-in G4 supply filter and G4 extract filter provide air filtration.

Control and automation

- The unit has three speeds. Air flow control by the external speed switch CDP-3/5.



Mounting

- Indoor installation in horizontal position.
- Mounting in a false ceiling is possible due to compact casing size.
- A small air distribution network for central ventilation may be arranged based on the unit.
- The correct mounted unit must provide free access to the hinged side panel for servicing and filter replacement.

FROST PROTECTION

- The integrated electronic frost protection system in **KOMFORT Ultra D 105-A** is used to prevent the heat exchanger freezing in cold seasons. In case of heat exchanger freezing danger communicated by the temperature sensor the supply fan is stopped to let warm extract air warm up the heat exchanger. After that the the supply fan is turned on and the unit reverts to the normal operation mode.

Designation key

Series	Unit type	Mounting type	Rated air flow [m³/h]	Heat exchanger material
KOMFORT	Ultra: compact unit	D: suspended mounting, horizontally directed spigots	105	-: enthalpy -A: polystyrene

Overall dimensions [mm]

Model	D	B	B1	B2	H	L	L1	L2
KOMFORT Ultra D 105	125	374	404	-	125	497	397	595
KOMFORT Ultra D 105-A	125	374	404	112.6	224	497	397	595

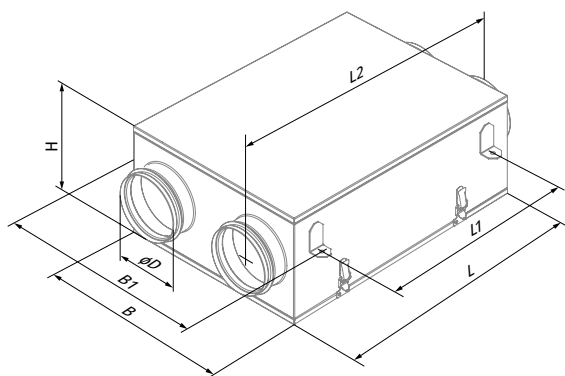

KOMFORT Ultra D 105

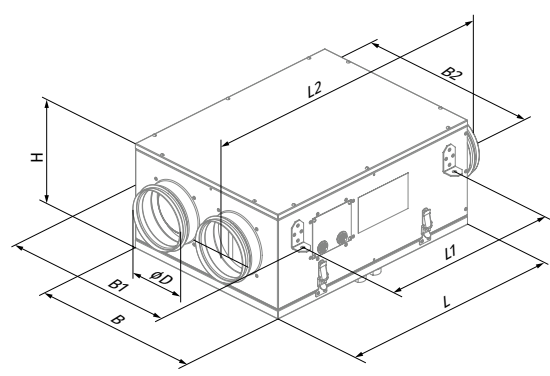



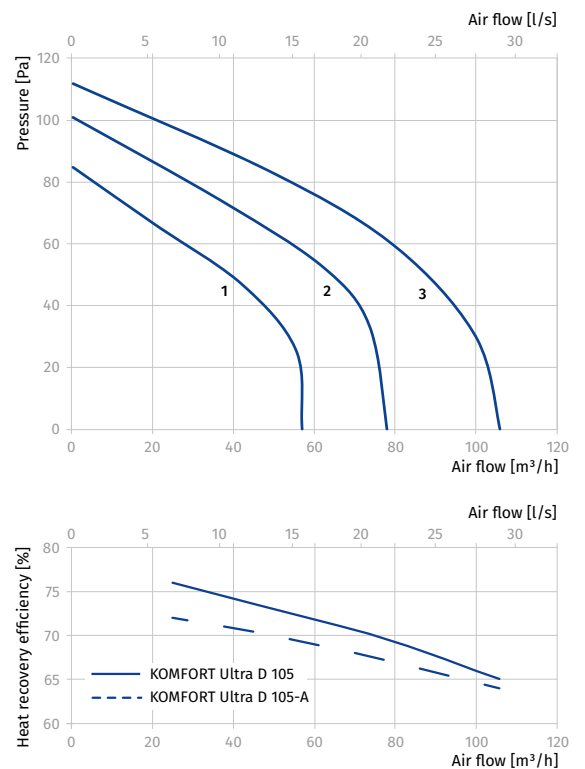

KOMFORT Ultra D 105-A

Technical data

Parameters	KOMFORT Ultra D 105			KOMFORT Ultra D 105-A			
	I	II	III	I	II	III	
Speed							
Voltage [V / 50 Hz]		1 ~ 230			1 ~ 230		
Power [W]	30	38	56	30	38	56	
Current [A]	0.18	0.23	0.34	0.18	0.23	0.34	
Maximum air flow [m ³ /h (l/s)]	57 (16)	78 (22)	106 (29)	57 (16)	78 (22)	106 (29)	
RPM [min ⁻¹]	1300	1950	2500	1300	1950	2500	
Sound pressure level at 3 m [dBA]	24	32	41	24	32	41	
Transported air temperature [°C]		-25...+40			-25...+40		
Casing material		aluzinc			aluzinc		
Insulation		15 mm polyethylene foam			15 mm polyethylene foam		
Extract / supply filter		G4			G4		
Connected air duct diameter [mm]		125			125		
Weight [kg]		10			13		
Heat recovery efficiency [%]		65–76			64–72		
Humidity recovery efficiency [%]		up to 45			-		
Heat exchanger type		cross-flow			cross-flow		
Heat exchanger material		enthalpy			polystyrene		
SEC class		D			D		
ErP		2016, 2018			2016, 2018		



Accessories

		KOMFORT Ultra D 105	KOMFORT Ultra D 105-A
G4 panel filter		FP 240x202x8 G4	FP 205x198x8 G4
Silencer		SD 125	SD 125
Backdraft air damper		VRV 125	VRV 125
Air damper		VK 125	VK 125
Summer block		SB C4 200/190	SB C4 200/190

KOMFORT EC S5(B) 270

Heat and energy recovery air handling units

Features

- Air handling units for efficient supply and exhaust ventilation in flats, houses, cottages and other buildings.
- Heat recovery minimizes ventilation heat losses during cold season and reduces air conditioner load during hot season.
- Controllable air exchange provides the best indoor microclimate.
- Compatible with round Ø 125 mm air ducts.



Air flow:
up to 300 m³/h
83 l/s



Heat recovery efficiency:
up to 98 %



Design

- The casing is made of expanded polypropylene (EPP) plates, 15–26 mm thick, possessing high heat- and sound-insulating properties.
- The unit is equipped with service panels for convenient maintenance of filters and heat exchanger.
- The spigots are located at the top of the unit and are rubber sealed for airtight connection to the air ducts.

Fans

- High-efficient external rotor EC motors and centrifugal impellers with backward curved blades are used for air supply and exhaust.
- EC motors have the best power consumption to air flow ratio and meet the latest demands concerning energy saving and high-efficient ventilation.
- EC motors are featured with high performance, low noise level and totally controllable speed range.
- Dynamically balanced impellers.

Air filtration

- The built-in G4 supply filter and G4 extract filter provide air filtration.
- The F8 supply filter (specially ordered accessory) may be used for efficient supply air filtration.

Bypass

- The **KOMFORT EC S5B 270(-E)** models are equipped with a bypass which can be opened to cool down the ventilated area with cool intake air, if required.

EPP HEAT AND ENERGY RECOVERY AIR HANDLING UNITS

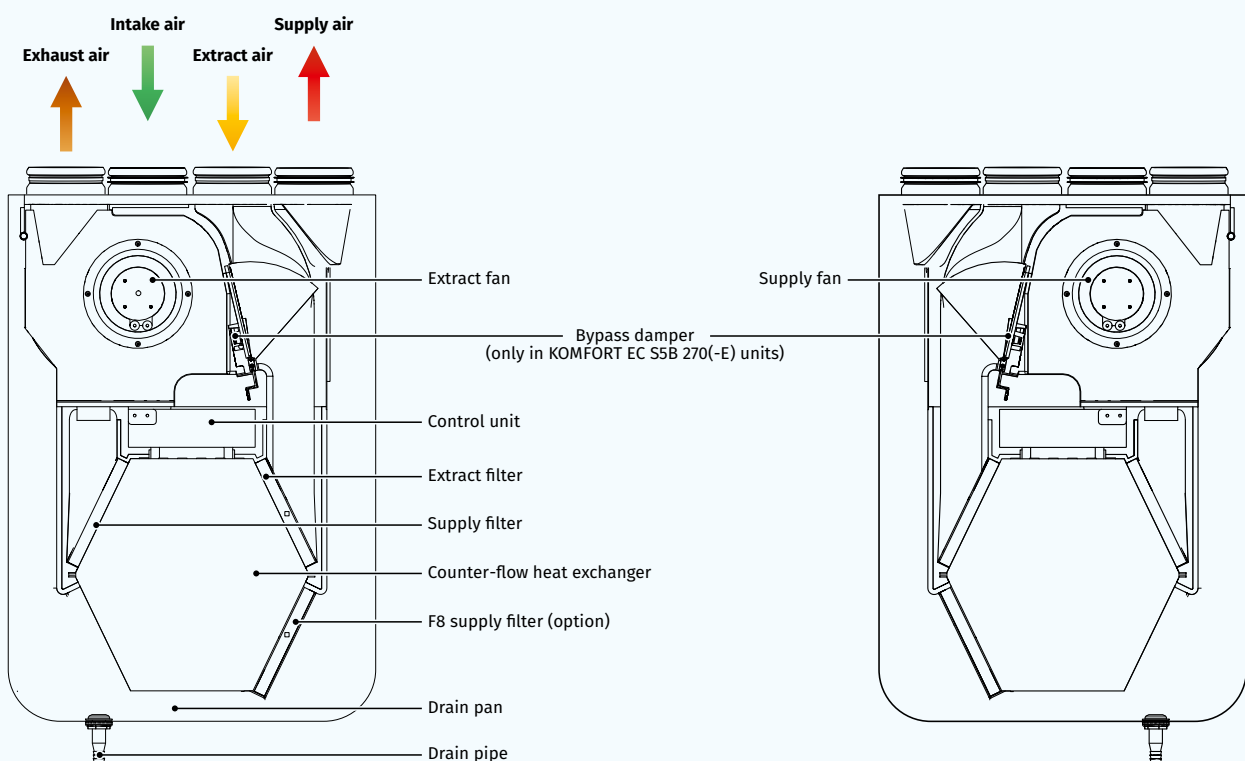

Heat recovery

The **KOMFORT EC S5(B) 270** unit is equipped with a plate counter-flow polystyrene heat exchanger for heat recovery. The unit condensate is collected and drained to the drain pan under the heat exchanger.



The **KOMFORT EC S5(B) 270-E** unit is equipped with an enthalpy plate counter-flow heat exchanger for energy (heat and humidity) recovery. Due to humidity recovery condensate is not generated in the enthalpy heat exchanger.



- The air flows are completely separated in the heat exchanger. Thus smells and contaminants are not transferred from the extract air to the supply air.
- Heat recovery is based on heat and/or humidity transfer through the heat exchanger plates. In the cold season supply air is heated in the heat exchanger by transferring the heat energy of warm and humid extract air to the cold fresh air. Heat recovery minimizes ventilation heat losses and heating costs respectively.
- In the warm season the heat exchanger performs reverse and intake air is cooled in the heat exchanger by the cool extract air. That reduces operation load on air conditioners and saves electricity.

Mounting

- The ventilation units are designed for wall and floor mounting.
- Due to universal casing design both left and right mounting is possible.

Control and automation

- The **KOMFORT EC S5B 270(-E) S21** units are equipped with an integrated automation system. The remote control panel is not included in the delivery set (sold separately).
- The S21 controller allows integrating the unit into the **Smart Home** system or **BMS (Building Management System)**.
- Unit control via Wi-Fi using the mobile application **Blauberg AHU**.



Download the **Blauberg AHU** app for Android

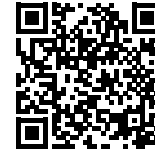





Download the **Blauberg AHU** app for iOS



- The **KOMFORT EC S5B 270 (-E) S14** units are equipped with an integrated automation system and the S14 wall mounted sensor control panel with LED-indication.
- The **KOMFORT EC S5 270 (-E) S2** units are equipped with the CDT E/0-10 speed controller.

Automation functions

Functions	KOMFORT EC S5B 270(-E) S21	KOMFORT EC S5B 270(-E) S14	KOMFORT EC S5 270(-E) S2
Unit control via Wi-Fi using a mobile application	+	-	-
Unit control via a remote wired control panel	S22 control panel (option) 	S14 control panel 	CDT E/0-10 speed controller 
Unit control via a remote wireless control panel	S22 Wi-Fi control panel (option) 	-	-
Unit control via a remote wired LCD control panel	S25 control panel (option) 	-	-
BMS (Building Management System)	RS-485	-	-
	Wi-Fi	-	-
	Ethernet	-	-
	MODBUS (RTU, TCP)	-	-
Blauberg Cloud Server service	+	-	-
Speed switch	+	+	+
Filter replacement indication	by filter timer	by filter timer	-
Alarm indication	full alarm description in the mobile application	LED indication about alarms	-
Week scheduled operation	+	-	-
Bypass	automatic	-	-
	manual	manual	-
Timer	+	-	-
Boost mode	+	-	-
Fireplace mode	+	-	-
Freeze protection	using cyclical stops of the supply fan	using cyclical stops of the supply fan	using cyclical stops of the supply fan
	using preheating (option)	-	-
Reheater connection	option	-	-
Cooler connection	option	-	-
Minimum supply air temperature control	+	-	-
Humidity control	option	option	-
CO ₂ control	option	option	-
VOC control	option	-	-
PM2.5 control	option	-	-
Fire alarm sensor connection	option	option	-

Option: the functionality is available when purchasing the appropriate accessory (see the "Accessories" section)

Designation key

Series	Motor type	Spigot orientation	Casing modification	Bypass	Rated air flow [m³/h]	Heat exchanger type	Control
KOMFORT	EC: electronically commutated motor	S: vertical spigot orientation	5: EPP	_ : without a bypass B: integrated bypass	270	_: heat recovery -E: energy recovery	S21 S14 S2

Overall dimensions [mm]

Model	Ø D	B	H	H1	L
KOMFORT EC S5(B) 270(-E) S21/S14/S2	125	590	852	893	316

	L1	L2	L3	H1	H2	H3
External automation unit (only units with S21 automation)	324	313	93	180	330	196

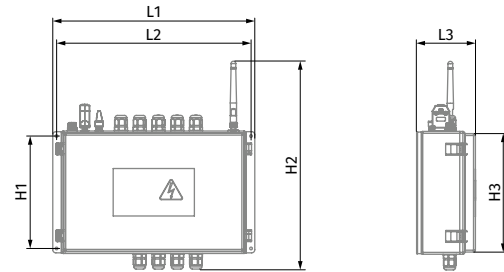
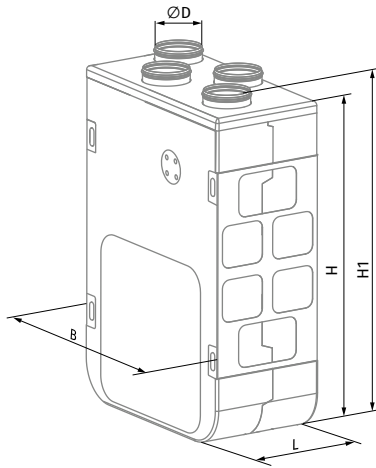

Technical data

Parameters	KOMFORT EC S5B 270 S21 KOMFORT EC S5B 270 S14 KOMFORT EC S5 270 S2	KOMFORT EC S5B 270-E S21 KOMFORT EC S5B 270-E S14 KOMFORT EC S5 270-E S2
Voltage [V / 50 (60) Hz]	1 ~ 230	1 ~ 230
Power [W]	162	162
Current [A]	1.2	1.2
Maximum air flow [m³/h (l/s)]	300 (83)	300 (83)
RPM [min⁻¹]	3200	3200
Sound pressure level at 3 m [dBA]	34	34
Transported air temperature [°C]	-25...+40	-25...+40
Casing material	EPP	EPP
Insulation	15-26 mm EPP	15-26 mm EPP
Extract filter	G4	G4
Supply filter	G4 (option: F8)	G4 (option: F8)
Connected air duct diameter [mm]	125	125
Weight [kg]	13	13.5
Heat recovery efficiency [%]	87-98	72-94
Heat exchanger type	counter-flow	counter-flow
Heat exchanger material	polystyrene	enthalpy
SEC class for S21 and S14 automation	A+	A
SEC class for S2 automation	B	B
ErP	2016, 2018	2016, 2018

Sound power level, A-weighted	Total	Octave frequency band [Hz]								LpA 3 m	LpA 1 m
		63	125	250	500	1000	2000	4000	8000		
LWA to supply inlet [dBA]	82	65	63	65	80	74	74	68	64		
LWA to supply outlet [dBA]	66	60	56	55	63	58	49	40	33		
LWA to exhaust inlet [dBA]	85	64	67	71	81	77	79	75	67		
LWA to exhaust outlet [dBA]	71	51	64	62	68	60	60	50	42		
LWA to environment [dBA]	55	37	45	44	53	43	43	40	38	34	44

Data provided for point 1 of the air flow diagram

Point	Unit power [W]	Sound pressure level at 3 m (1 m) [dBA]
1	153	34 (44)
2	150	34 (44)
3	142	33 (43)
4	62	30 (40)
5	60	29 (39)
6	59	28 (38)
7	17	27 (37)
8	17	23 (33)
9	16	23 (33)

BRE

Exhaust spigot configuration	Air flow rate [l/s]	Specific fan power [W/l/s]	Heat exchange efficiency [%]
Kitchen + 1 additional wet room	21	0.73	85
Kitchen + 2 additional wet rooms	29	0.86	84
Kitchen + 3 additional wet rooms	37	1.08	82
Kitchen + 4 additional wet rooms	45	1.39	81

Calculation of air temperature downstream of the heat exchanger:

$$t = t_{\text{outd}} + k_{\text{hr}} \times (t_{\text{extr}} - t_{\text{outd}}) / 100,$$

where

- t_{outd} – outdoor air temperature [°C]
- t_{extr} – extract air temperature [°C]
- k_{hr} – heat exchanger efficiency (according to the diagram) [%]

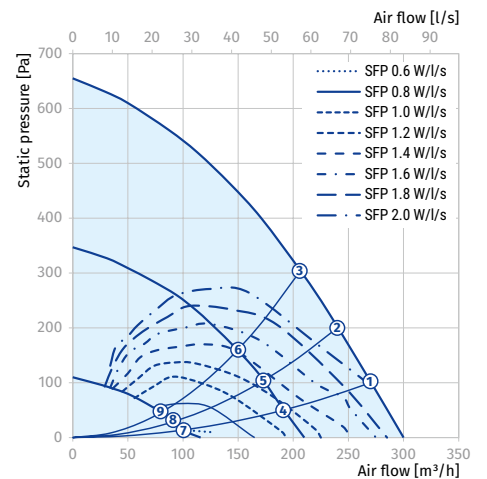



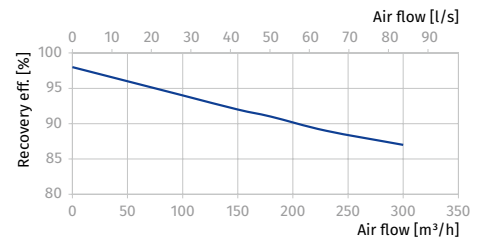



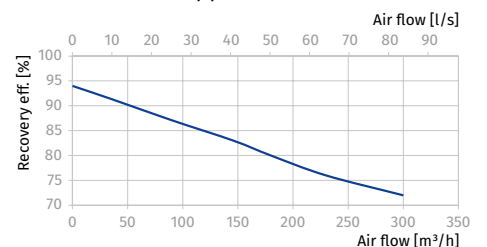









KOMFORT EC S5(B) 270





KOMFORT EC S5(B) 270-E



Accessories

		KOMFORT EC S5B 270(-E) S21	KOMFORT EC S5B 270(-E) S14
G4 panel filter		FP 264x182x18 G4	FP 264x182x18 G4
F8 panel filter		FP 264x182x18 F8	FP 264x182x18 F8
Control panel		S22	-
Wireless control panel		S22 Wi-Fi	-
LCD control panel		S25	-
Humidity sensor		FS2	FS2
Humidity sensor		HR-S	HR-S
CO ₂ sensor		CD-2	CD-2
CO ₂ sensor with indication		CD-1	CD-1
VOC sensor		DPWQ30600	-
CO ₂ sensor		DPWQ40200	-
Humidity sensor		DPWC11200	-
Electric preheater		EVH 125	-
Electric reheater		ENH 125	-
Syphon kit (for the units without an enthalpy heat exchanger)		SFK 20x32	SFK 20x32
Air damper		VKA 125	VKA 125
Electric actuator		LF230	LF230

KOMFORT EC S5 270(-E) S2		
G4 panel filter		FP 264x182x18 G4
F8 panel filter		FP 264x182x18 F8
Syphon kit (for the units without an enthalpy heat exchanger)		SFK 20x32

KOMFORT EC D5(B) 180

Heat and energy recovery air handling units

Features

- Air handling units for efficient supply and exhaust ventilation in flats, houses, cottages and other buildings.
- Heat recovery minimizes ventilation heat losses during cold season and reduce air conditioner load during hot season.
- Controllable air exchange for creating the best suitable indoor microclimate.
- Compatible with round Ø 150 mm air ducts.



Air flow:
up to 220 m³/h
61 l/s



Heat recovery efficiency:
up to 98 %



Design

- The casing is made of expanded polypropylene (EPP) 15–30 mm thick with high heat- and sound-insulating properties.
- The spigots are located at the side of the unit and are rubber sealed for airtight connection to the air ducts.

Fans

- High-efficient external rotor EC motors and centrifugal impellers with forward curved blades are used for air supply and exhaust.

- EC motors have the best power consumption to air flow ratio and meet the latest demands concerning energy saving and high-efficient ventilation.
- EC motors are featured with high performance, low noise level and totally controllable speed range.
- Dynamically balanced impellers.

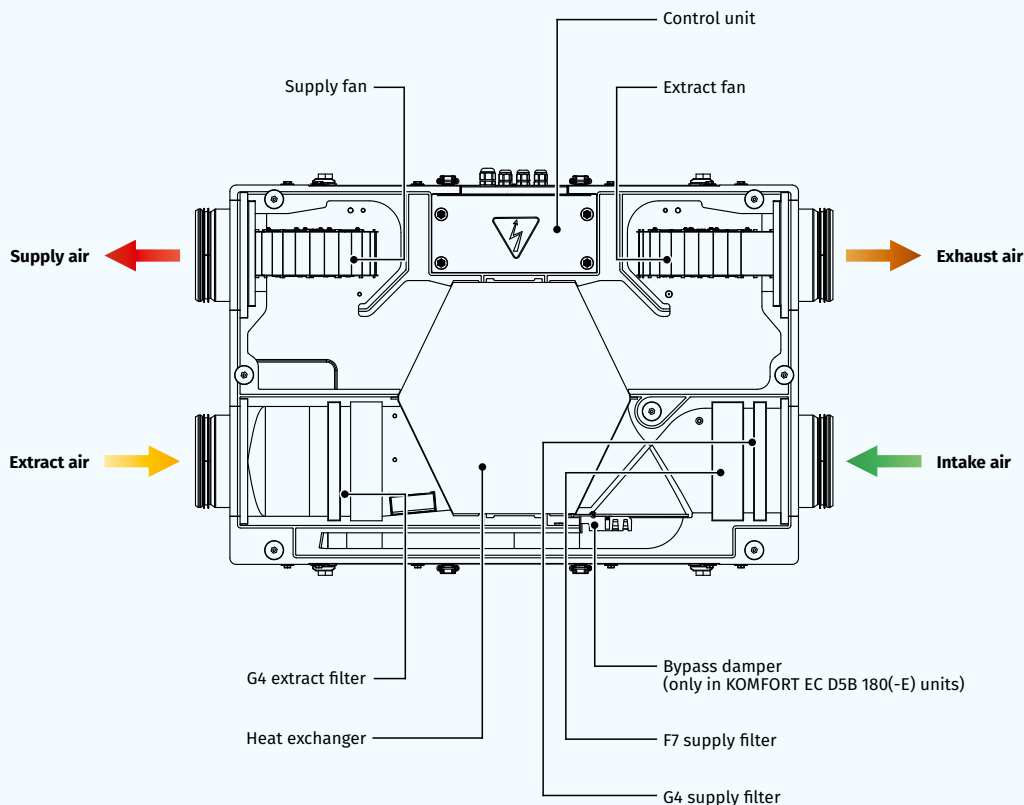

Air filtration

- Two built-in G4 and F7 filters provide efficient supply air filtration.
- The G4 filter is used for extract air filtration.

Heat recovery

- The **KOMFORT EC D5(B) 180** unit is equipped with a plate counter-flow polystyrene heat exchanger for heat recovery. The unit condensate is collected and drained to the drain pan under the heat exchanger.



- The **KOMFORT EC D5(B) 180-E** unit is equipped with an enthalpy plate counter-flow heat exchanger for energy (heat and humidity) recovery. Due to humidity recovery condensate is not generated in the enthalpy heat exchanger.



- The air flows are completely separated in the heat exchanger. Thus smells and contaminants are not transferred from the extract air to the supply air.
- Heat recovery is based on heat and/or humidity transfer through the heat exchanger plates. In the cold season supply air is heated in the heat exchanger by transferring the heat energy of warm and humid extract air to the cold fresh air. Heat recovery minimizes ventilation heat losses and heating costs respectively.
- In the warm season the heat exchanger performs reverse and intake air is cooled in the heat exchanger by the cool extract air. That reduces operation load on air conditioners and saves electricity.

Bypass

- The **KOMFORT EC D5B 180(-E)** models are equipped with a bypass which can be opened if there is a need to cool down the ventilated area with cool intake air.

Mounting

- The units are designed for suspended ceiling mounting, vertical or horizontal wall mounting.
- Sufficient service access for maintenance and filter replacement must be provided.

Control and automation

- The **KOMFORT EC D5B 180(-E) S21** units are equipped with an integrated automation system. The remote control panel is not included in the delivery set (sold separately).
- The S21 controller allows integrating the unit into the **Smart Home** system or **BMS (Building Management System)**.
- Unit control via Wi-Fi using the mobile application **Blauberg AHU**.



Download the **Blauberg AHU** app for Android





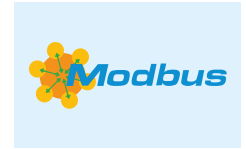

Download the **Blauberg AHU** app for iOS



- The **KOMFORT EC D5B 180(-E) S14** units are equipped with an integrated automation system and an S14 wall mounted sensor control panel with LED-indication.
- The **KOMFORT EC D5 180(-E) S2** units are equipped with a CDT E/0-10 speed regulator.

Automation functions

Functions	KOMFORT EC D5B 180(-E) S21	KOMFORT EC D5B 180(-E) S14	KOMFORT EC D5 180(-E) S2
Unit control via Wi-Fi using a mobile application	+	-	-
Unit control via a remote wired control panel	S22 control panel (option) 	S14 control panel 	CDT E/0-10 speed controller 
Unit control via a remote wireless control panel	S22 Wi-Fi control panel (option) 	-	-
Unit control via a remote wired LCD control panel	S25 control panel (option) 	-	-
BMS (Building Management System)	RS-485	-	-
	Wi-Fi	-	-
	Ethernet	-	-
	MODBUS (RTU, TCP)	-	-
Blauberg Cloud Server service	+	-	-
Speed switch	+	+	+
Filter replacement indication	by filter timer	by filter timer	-
Alarm indication	full alarm description in the mobile application	LED indication about alarms	-
Week scheduled operation	+	-	-
Bypass	automatic	-	-
	manual	manual	-
Timer	+	-	-
Boost mode	+	-	-
Fireplace mode	+	-	-
Freeze protection	using cyclical stops of the supply fan	using cyclical stops of the supply fan	using cyclical stops of the supply fan
	using preheating (option)	-	-
Reheater connection	option	-	-
Cooler connection	option	-	-
Minimum supply air temperature control	+	-	-
Humidity control	option	option	-
CO ₂ control	option	option	-
VOC control	option	-	-
PM2.5 control	option	-	-
Fire alarm sensor connection	option	option	-

Option: the functionality is available when purchasing the appropriate accessory (see the "Accessories" section)

Designation key

Series	Motor type	Spigot orientation	Casing modification	Bypass	Rated air flow [m ³ /h]	Heat exchanger type	Control
KOMFORT	EC: electronically commutated motor	D: suspended mounting, horizontally directed spigots	5: EPP	_ : without a bypass B: integrated bypass	180	_: heat recovery -E: energy recovery	S21 S14 S2

Overall dimensions [mm]

Model	∅ D	∅ D1	B	B1	B2	B3	L	L1	L2	H	H1	H2
KOMFORT EC D5(B) 180 S21/S14/S2	150	19	650	600	326	163	900	1009	302	264	110	38
KOMFORT EC D5(B) 180-E S21/S14/S2	150	-	650	600	326	163	900	1009	302	264	110	-

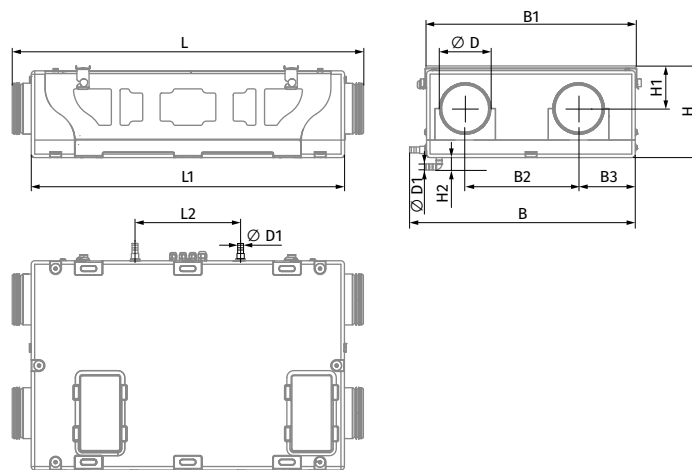

Technical data

Parameters	KOMFORT EC D5B 180 S21 KOMFORT EC D5B 180 S14 KOMFORT EC D5 180 S2	KOMFORT EC D5B 180-E S21 KOMFORT EC D5B 180-E S14 KOMFORT EC D5 180 S2
Voltage [V / 50 (60) Hz]	1 ~ 230	1 ~ 230
Power [W]	87	87
Current [A]	0.71	0.71
Maximum air flow [m³/h (l/s)]	220 (61)	220 (61)
RPM [min⁻¹]	2200	2200
Sound pressure level at 3 m [dBA]	33	33
Transported air temperature [°C]	-25...+40	-25...+40
Casing material	EPP	EPP
Insulation	15-30 mm EPP	15-30 mm EPP
Extract filter	G4	G4
Supply filter	G4+ F7	G4+F7
Connected air duct diameter [mm]	150	150
Weight [kg]	14	14
Heat recovery efficiency [%]	86-98	79-94
Heat exchanger type	counter-flow	counter-flow
Heat exchanger material	polystyrene	enthalpy
SEC class for S21 and S14 automation	A+	A+
SEC class for S2 automation	A	A
ErP	2016, 2018	2016, 2018

Sound power level, A-weighted	Total	Octave frequency band [Hz]								LpA 3 m	LpA 1 m
		63	125	250	500	1000	2000	4000	8000		
LWA to supply inlet [dBA]	59	27	46	54	55	53	48	44	35		
LWA to supply outlet [dBA]	60	27	46	54	55	53	49	44	35		
LWA to exhaust inlet [dBA]	55	25	41	50	51	44	42	39	30		
LWA to exhaust outlet [dBA]	55	26	41	51	51	44	42	39	31		
LWA to environment [dBA]	54	18	36	47	49	48	43	37	33	33	43

Data provided for point 1 of the air flow diagram

Point	Unit power [W]	Sound pressure level at 3 m (1 m) [dBA]
1	77	33 (43)
2	64	33 (43)
3	53	32 (42)
4	31	29 (39)
5	30	28 (38)
6	26	27 (37)
7	14	23 (33)
8	13	21 (31)
9	12	19 (29)

BRE

Exhaust spigot configuration	Air flow rate [l/s]	Specific fan power [W/l/s]	Heat exchange efficiency [%]
Kitchen + 1 additional wet room	21	0.90	0.88
Kitchen + 2 additional wet rooms	29	1.00	0.86
Kitchen + 3 additional wet rooms	37	1.20	0.85

Calculation of air temperature downstream of the heat exchanger:

$$t = t_{\text{outd}} + k_{\text{hr}} \times (t_{\text{extr}} - t_{\text{outd}}) / 100,$$

where







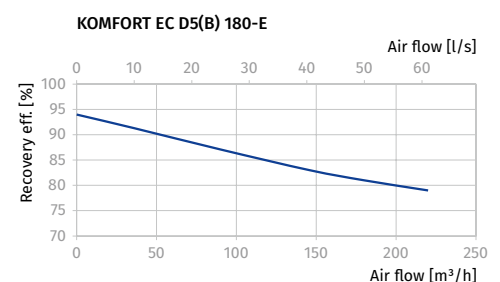
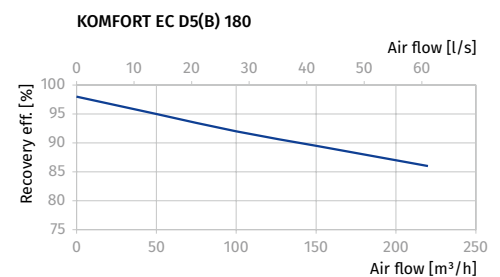
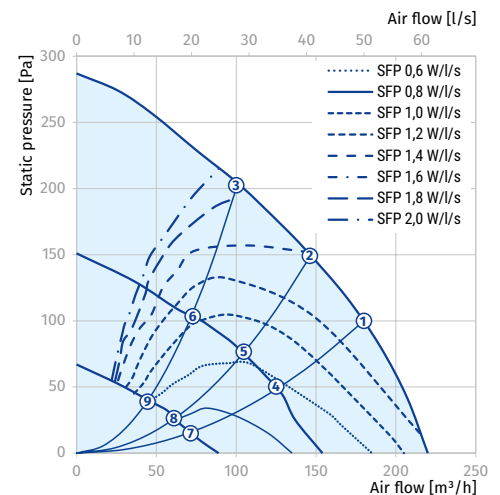











t_{outd} – outdoor air temperature [°C]





t_{extr} – extract air temperature [°C]

k_{hr} – heat exchanger efficiency (according to the diagram) [%]



Accessories

		KOMFORT EC D5(B) 180(-E) S21	KOMFORT EC D5(B) 180(-E) S14
G4 panel filter		FP 214x186x18 G4	FP 214x186x18 G4
F7 panel filter		FP 214x186x48 F7	FP 214x186x48 F7
Control panel		S22	-
Wireless control panel		S22 Wi-Fi	-
LCD control panel		S25	-
Humidity sensor		FS2	FS2
Humidity sensor		HR-S	HR-S
CO ₂ sensor		CD-2	CD-2
CO ₂ sensor with indication		CD-1	CD-1
VOC sensor		DPWQ30600	-
CO ₂ sensor		DPWQ40200	-
Humidity sensor		DPWC11200	-
Electrical preheater		EVH 150	-
Electrical reheater		ENH 150	-
Syphon kit (for the units without an enthalpy heat exchanger)		SFK 20x32	SFK 20x32
Silencer		SD 150	SD 150
Air damper		VKA 150	VKA 150
Electric actuator		LF230	LF230

KOMFORT EC D5 180(-E) S2		
G4 panel filter		FP 214x186x18 G4
F8 panel filter		FP 214x186x48 F7
Silencer		SD 150
Syphon kit (for the units without an enthalpy heat exchanger)		SFK 20x32

KOMFORT EC S(B)

Heat and humidity recovery air handling units

Features

- Air handling units for efficient energy saving supply and exhaust ventilation in flats, houses, cottages and other premises.
- Heat and humidity recovery minimizes ventilation heat losses during cold season and reduces air conditioner load during hot season.
- Controllable air exchange for creating the best suitable indoor microclimate.
- Compatible with round Ø 125, 160 or 200 mm air ducts.



Air flow:
up to 690 m³/h
192 l/s



Heat recovery efficiency:
up to 98 %



Design

- The casing is made of double-skinned polymer-coated steel panels, internally filled with 20, 25, 30, 40 mm (depending on the unit model) mineral wool layer for heat- and sound-insulation.
- The unit is equipped with a hinged service panel to enable convenient access for maintenance or repair operations.
- The spigots are located at the top of the unit and are equipped with rubber seals for airtight connection to the air ducts.

Fans

- The units are equipped with high-efficient EC motors with an external rotor and a centrifugal impeller with backward curved blades.
- EC motors have the best power consumption to air capacity ratio and meet the latest demands concerning energy saving and high-efficient ventilation.
- EC motors are featured with high performance, low noise level and optimum control across the entire speed range.
- The impellers are dynamically balanced.

Air filtration

- The built-in F7 filter provides efficient supply air filtration. The G4 filter is used for extract air cleaning.
- The G3 filters are used for supply and exhaust air filtration in the **KOMFORT EC S(B) 200** units.
- Supply air in the **KOMFORT EC S(B) 250** units is purified by the G4 and F7 filters. The G4 filter is used for extract air cleaning.

Bypass

- The **KOMFORT EC SB(-E)** units are equipped with a bypass for ventilation (air cooling by the cool air from outside).

HEAT RECOVERY AIR HANDLING UNITS

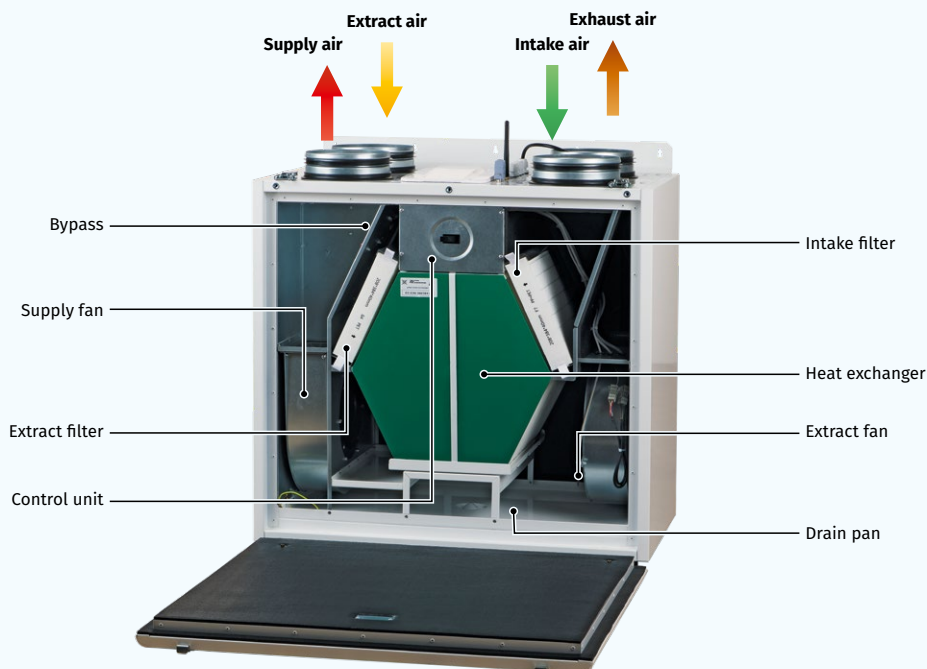

Heat recovery

- The **KOMFORT EC S(B)** unit is equipped with a plate counter-flow polystyrene heat exchanger for heat recovery. The unit condensate is collected and drained to the drain pan under the heat exchanger.
- The **KOMFORT EC S(B)-E** unit is equipped with an enthalpy plate counter-flow heat exchanger for energy (heat and humidity) recovery. Due to humidity recovery condensate is not generated in the enthalpy heat exchanger.
- The air flows are completely separated in the heat exchanger. Thus smells and contaminants are not transferred from the extract air to the supply air.
- Heat recovery is based on heat and/or humidity transfer through the heat exchanger plates. In the cold season supply air is heated in the heat exchanger by transferring the heat energy of warm and humid extract air to the cold fresh air. Heat recovery minimizes ventilation heat losses and heating costs respectively.
- In the warm season the heat exchanger performs reverse and intake air is cooled in the heat exchanger by the cool extract air. That reduces operation load on air conditioners and saves electricity.
- When the indoor and outdoor temperature difference is insignificant, heat recovery is not reasonable. In this case the heat exchanger can be temporary replaced with a summer block for the warm season (available as a specially ordered accessory).



Mounting

- The units are designed for wall or floor mounting.
- Universal casing design provides either left-handed or right-handed unit installation.

Control and automation

- The **KOMFORT EC S(B)-E S21** units are equipped with an integrated automation system. The remote control panel is not included in the delivery set (available separately).
- The S21 controller allows integrating the unit into the **Smart Home** system or **BMS (Building Management System)**.
- The unit can be controlled by the **Blauberg AHU** mobile application via Wi-Fi.



Download the **Blauberg AHU** app for Android





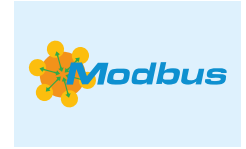

Download the **Blauberg AHU** app for iOS



- The **KOMFORT EC S(B)-E S14** units have an integrated automation system with a wall-mounted control panel S14 with a LED indication.
- The **KOMFORT EC S(B) 200** are available only with an S14 automation.

Automation functions

Functions	KOMFORT EC S(B)-E S21	KOMFORT EC S(B)-E S14
Unit control via Wi-Fi using a mobile application	+	-
Unit control via a wired remote control panel	S22 control panel (option) 	S14 control panel 
Unit control via a wireless remote control panel	S22 Wi-Fi control panel (option) 	-
Unit control via a remote wired LCD control panel	S25 control panel (option) 	-
BMS (Building Management System)	RS-485	-
	Wi-Fi	-
	Ethernet	-
	MODBUS (RTU, TCP)	-
Blauberg Cloud Server service	+	-
Speed selection	+	+
Filter replacement indication	by filter timer	by filter timer
	by filter clogging differential pressure switch (KOMFORT EC SB 550)	-
Alarm indication	full alarm description in the mobile application	LED alarm indication
Week-scheduled operation	+	-
Bypass	automatic	-
	manual	manual
Timer	+	-
Boost mode	+	-
Fireplace mode	+	-
Freeze protection	through cyclic stops of the supply fan	through cyclic stops of the supply fan
	through preheating (option)	-
Reheater connection	option	-
Cooler connection	option	-
Minimum supply air temperature control	+	-
Humidity control	option	option
CO ₂ control	option	option
VOC control	option	-
PM2.5 control	option	-
Fire alarm sensor connection	option	option

Option: function is available when purchasing the appropriate accessory (see the "Accessories" section).

Designation key

Series	Motor type	Spigot modification	Bypass	Rated air flow, [m³/h]	Heat exchanger type	Control
KOMFORT	EC: electronically commutated motor	S: vertical spigot orientation	_: no bypass B: with a bypass	160; 200; 250; 350; 550	_: heat recovery -E: energy recovery	S21 S14

Overall dimensions [mm]

Model	Ø D	B	B1	H	H1	L
KOMFORT EC S 160(-E) S21/S14	125	330	340	550	665	600
KOMFORT EC SB 160(-E) S21/S14	125	330	340	580	665	600
KOMFORT EC S 200(-E) S14	124	290	326	773	842	564
KOMFORT EC SB 200(-E) S14	124	290	326	773	842	564
KOMFORT EC S 250(-E) S14	160	450	489	790	853	567
KOMFORT EC SB 250(-E) S21/S14	160	450	489	790	853	567
KOMFORT EC SB 350(-E) S21/S14	160	583	600	675	760	730
KOMFORT EC SB 550(-E) S21/S14	200	720	730	675	760	823

HEAT RECOVERY AIR HANDLING UNITS

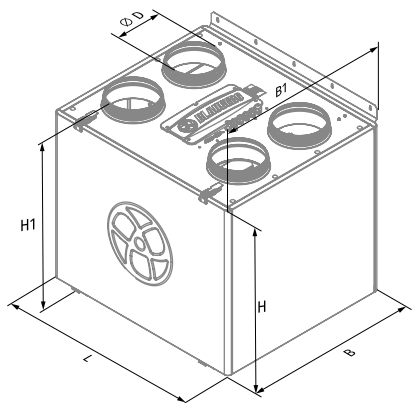

KOMFORT EC S 160(-E) S21/S14
KOMFORT EC SB 160(-E) S21/S14
KOMFORT EC SB 350(-E) S21/S14
KOMFORT EC SB 550(-E) S21/S14

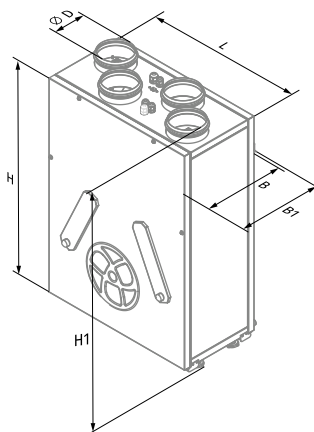

KOMFORT EC S 200(-E) S14
KOMFORT EC SB 200(-E) S14

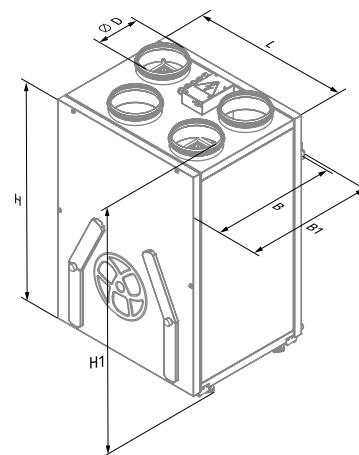

KOMFORT EC S 250(-E) S14
KOMFORT EC SB 250(-E) S21/S14

Technical data

Parameters	KOMFORT EC S 160 S21 KOMFORT EC S 160 S14	KOMFORT EC S 160-E S21 KOMFORT EC S 160-E S14	KOMFORT EC SB 160 S21 KOMFORT EC SB 160 S14	KOMFORT EC SB 160-E S21 KOMFORT EC SB 160-E S14
Supply voltage [V / 50 (60) Hz]	1~ 230	1~ 230	1~ 230	1~ 230
Power [W]	57	57	57	57
Current [A]	0.5	0.5	0.5	0.5
Maximum air flow [m³/h (l/s)]	200 (56)	200 (56)	200 (56)	200 (56)
RPM [min⁻¹]	3770	3770	3770	3770
Sound pressure level at a distance of 3 m [dBA]	24	24	24	24
Transported air temperature [°C]	-25...+40	-25...+40	-25...+40	-25...+40
Casing material	polymer-coated steel	polymer-coated steel	polymer-coated steel	polymer-coated steel
Insulation	20 mm mineral wool	20 mm mineral wool	20 mm mineral wool	20 mm mineral wool
Extract filter	G4	G4	G4	G4
Supply filter	F7 (option: G4)	F7 (option: G4)	F7 (option: G4)	F7 (option: G4)
Connected air duct diameter [mm]	125	125	125	125
Weight [kg]	34	34	36	36
Heat recovery efficiency [%]	85–93	76–92	85–93	76–92
Heat exchanger type	counter-flow	counter-flow	counter-flow	counter-flow
Heat exchanger material	polystyrene	enthalpy	polystyrene	enthalpy
SEC class	A+	A	A+	A
ErP	2016, 2018	2016, 2018	2016, 2018	2016, 2018

KOMFORT EC S(B) 160(-E)

Sound power level, A-weighted	Total	Octave frequency band [Hz]								LpA 3 m	LpA 1 m
		63	125	250	500	1000	2000	4000	8000		
LWA to supply inlet [dBA]	52	28	46	49	41	35	33	36	29		
LWA to supply outlet [dBA]	60	32	52	58	47	37	36	41	35		
LWA to exhaust inlet [dBA]	51	27	45	49	41	36	32	35	29		
LWA to exhaust outlet [dBA]	60	31	50	59	48	36	36	41	32		
LWA to environment [dBA]	45	25	41	42	34	31	28	27	22	24	34

Data provided for point 1 of the air flow diagram

Point	Total power of the unit [W]	Sound pressure level at 3 m (1 m) [dBA]
1	57	24 (34)
2	56	23 (33)
3	54	23 (33)
4	28	20 (30)
5	27	20 (30)
6	26	20 (30)
7	14	13 (23)
8	13	13 (23)
9	13	13 (23)

Calculation of air temperature downstream of the heat exchanger:

$$t = t_{\text{outd}} + k_{\text{hr}} \times (t_{\text{extr}} - t_{\text{outd}}) / 100,$$

where

t_{outd} – outdoor air temperature [°C]

t_{extr} – extract air temperature [°C]

k_{hr} – heat exchanger efficiency (according to the diagram) [%]

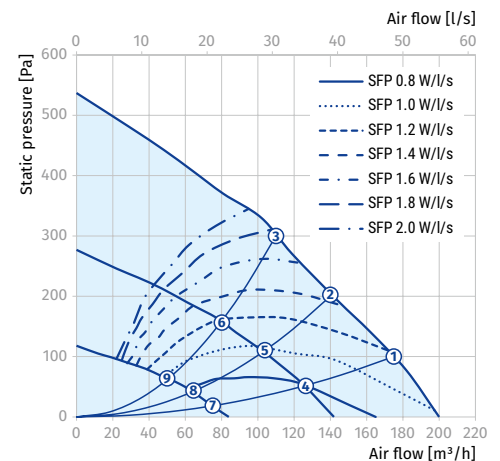

KOMFORT EC S(B) 160

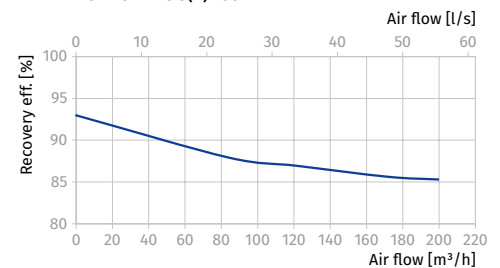

KOMFORT EC S(B) 160-E

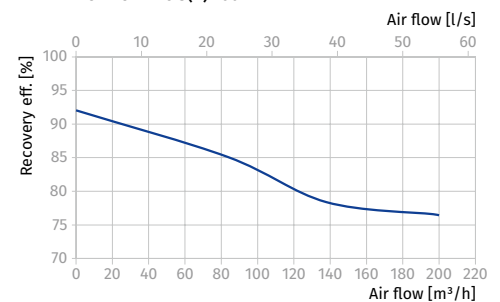

Parameters	KOMFORT EC S 200 S14	KOMFORT EC S 200-E S14	KOMFORT EC SB 200 S14	KOMFORT EC SB 200-E S14
Supply voltage [V / 50 (60) Hz]	1~ 230	1~ 230	1~ 230	1~ 230
Power [W]	112	112	112	112
Current [A]	0.9	0.9	0.9	0.9
Maximum air flow [m³/h (l/s)]	250 (69)	250 (69)	250 (69)	250 (69)
RPM [min ⁻¹]	2050	2050	2050	2050
Sound pressure level at a distance of 3 m [dBA]	24	24	24	24
Transported air temperature [°C]	-25...+40	-25...+40	-25...+40	-25...+40
Casing material	polymer-coated steel	polymer-coated steel	polymer-coated steel	polymer-coated steel
Insulation	25 mm mineral wool	25 mm mineral wool	25 mm mineral wool	25 mm mineral wool
Extract filter	G3	G3	G3	G3
Supply filter	G3	G3	G3	G3
Connected air duct diameter [mm]	125	125	125	125
Weight [kg]	45	45	45	45
Heat recovery efficiency [%]	83–98	74–94	83–98	74–94
Heat exchanger type	counter-flow	counter-flow	counter-flow	counter-flow
Heat exchanger material	polystyrene	enthalpy	polystyrene	enthalpy
SEC class	A+	A	A+	A
ErP	2016, 2018	2016, 2018	2016, 2018	2016, 2018

KOMFORT EC S(B) 200 (-E)

Sound power level, A-weighted	Total	Octave frequency band [Hz]								LpA 3 m	LpA 1 m
		63	125	250	500	1000	2000	4000	8000		
L _{WA} to supply inlet [dBA]	51	28	46	49	41	35	33	36	29		
L _{WA} to supply outlet [dBA]	60	32	52	58	47	37	36	41	35		
L _{WA} to exhaust inlet [dBA]	51	27	44	49	41	35	32	34	29		
L _{WA} to exhaust outlet [dBA]	60	31	50	59	48	36	36	41	32		
L _{WA} to environment [dBA]	44	24	40	41	34	31	27	26	22	24	34

Data provided for point 1 of the air flow diagram

Point	Total power of the unit [W]	Sound pressure level at 3 m (1 m) [dBA]
1	103	24 (34)
2	95	23 (33)
3	88	23 (33)
4	42	19 (29)
5	38	18 (28)
6	36	18 (28)
7	16	12 (22)
8	15	12 (22)
9	15	11 (21)

BRE

Exhaust spigot configuration	Air flow [l/s]	Specific fan power input [W/l/s]	Heat exchange efficiency [%]
Kitchen + 1 additional room with high level of humidity	21	0.67	87
Kitchen + 2 additional rooms with high levels of humidity	29	0.69	85
Kitchen + 3 additional rooms with high levels of humidity	37	0.88	84
Kitchen + 4 additional rooms with high levels of humidity	45	1.13	83
Kitchen + 5 additional rooms with high levels of humidity	53	1.37	83

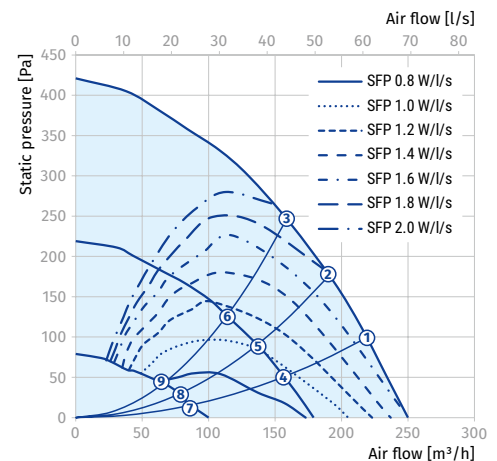

KOMFORT EC S(B) 200

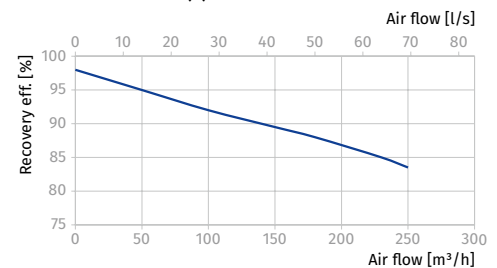

KOMFORT EC S(B) 200-E

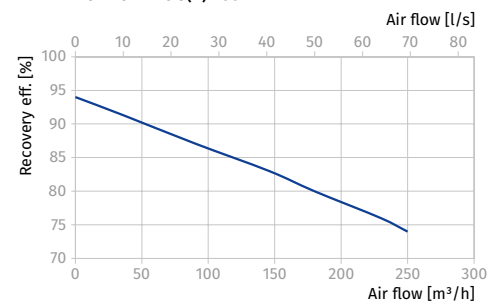

Parameters	KOMFORT EC S 250 S14	KOMFORT EC S 250-E S14	KOMFORT EC SB 250 S21 KOMFORT EC SB 250 S14	KOMFORT EC SB 250-E S21 KOMFORT EC SB 250-E S14
Supply voltage [V / 50 (60) Hz]	1~ 230	1~ 230	1~ 230	1~ 230
Power [W]	115	115	115	115
Current [A]	0.9	0.9	0.9	0.9
Maximum air flow [m³/h (l/s)]	290 (81)	290 (81)	290 (81)	290 (81)
RPM [min⁻¹]	2050	2050	2050	2050
Sound pressure level at a distance of 3 m [dBA]	25	25	25	25
Transported air temperature [°C]	-25...+40	-25...+40	-25...+40	-25...+40
Casing material	polymer-coated steel	polymer-coated steel	polymer-coated steel	polymer-coated steel
Insulation	30 mm mineral wool	30 mm mineral wool	30 mm mineral wool	30 mm mineral wool
Extract filter	G4	G4	G4	G4
Supply filter	G4+F7	G4+F7	G4+F7	G4+F7
Connected air duct diameter [mm]	160	160	160	160
Weight [kg]	51	51	51	51
Heat recovery efficiency [%]	85–94	78–90	85–94	78–90
Heat exchanger type	counter-flow	counter-flow	counter-flow	counter-flow
Heat exchanger material	polystyrene	enthalpy	polystyrene	enthalpy
SEC class	A+	A	A+	A
ErP	2016, 2018	2016, 2018	2016, 2018	2016, 2018

KOMFORT EC S(B) 250 (-E)

Sound power level, A-weighted	Total	Octave frequency band [Hz]								LpA 3 m	LpA 1 m
		63	125	250	500	1000	2000	4000	8000		
LWA to supply inlet [dBA]	52	28	46	50	41	36	33	36	29		
LWA to supply outlet [dBA]	61	33	53	60	48	38	37	43	36		
LWA to exhaust inlet [dBA]	52	28	46	50	42	36	33	35	30		
LWA to exhaust outlet [dBA]	62	32	51	61	49	37	37	42	33		
LWA to environment [dBA]	45	25	41	42	35	32	28	27	22	25	35

Data provided for point 1 of the air flow diagram

Point	Total power of the unit [W]	Sound pressure level at 3 m (1 m) [dBA]
1	106	25 (35)
2	95	24 (34)
3	82	24 (34)
4	44	20 (30)
5	40	19 (29)
6	36	19 (29)
7	16	13 (23)
8	15	12 (22)
9	15	12 (22)

BRE

Exhaust spigot configuration	Air flow [l/s]	Specific fan power input [W/l/s]	Heat exchange efficiency [%]
Kitchen + 1 additional room with high level of humidity	21	0.65	92
Kitchen + 2 additional rooms with high levels of humidity	29	0.68	91
Kitchen + 3 additional rooms with high levels of humidity	37	0.77	90
Kitchen + 4 additional rooms with high levels of humidity	45	0.94	89
Kitchen + 5 additional rooms with high levels of humidity	53	1.12	88
Kitchen + 6 additional rooms with high levels of humidity	61	1.35	87
Kitchen + 7 additional rooms with high levels of humidity	69	1.70	86

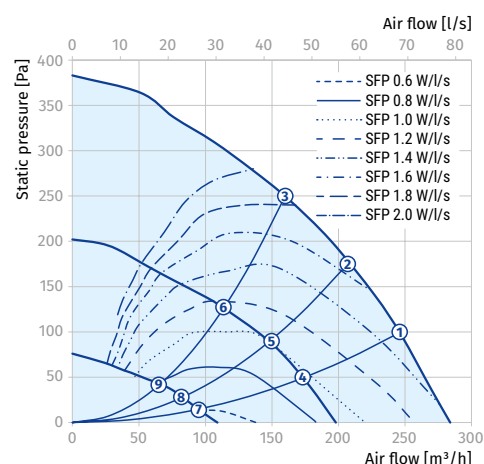

KOMFORT EC S(B) 200-E

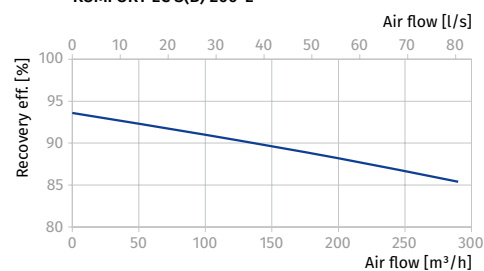

KOMFORT EC S(B) 250-E

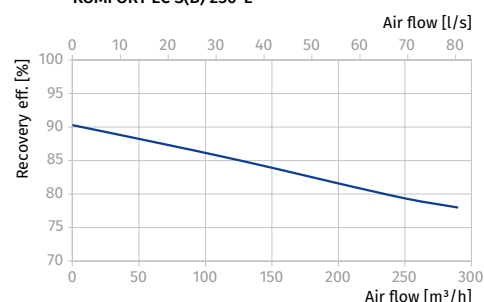

Parameters	KOMFORT EC SB 350 S21 KOMFORT EC SB 350 S14	KOMFORT EC SB 350-E S21 KOMFORT EC SB 350-E S14
Supply voltage [V / 50 (60) Hz]	1~ 230	1~ 230
Power [W]	178	178
Current [A]	1.4	1.4
Maximum air flow [m³/h (l/s)]	450 (125)	450 (125)
RPM [min ⁻¹]	3200	3200
Sound pressure level at a distance of 3 m [dBA]	28	28
Transported air temperature [°C]	-25...+40	-25...+40
Casing material	polymer-coated steel	polymer-coated steel
Insulation	40 mm mineral wool	40 mm mineral wool
Extract filter	G4	G4
Supply filter	F7 (option: G4)	F7 (option: G4)
Connected air duct diameter [mm]	160	160
Weight [kg]	64	64
Heat recovery efficiency [%]	85-92	73-91
Heat exchanger type	counter-flow	counter-flow
Heat exchanger material	polystyrene	enthalpy
SEC class	A+	A
ErP	2016, 2018	2016, 2018

KOMFORT EC SB 350(-E)

Sound power level, A-weighted	Total	Octave frequency band [Hz]								LpA 3 m	LpA 1 m
		63	125	250	500	1000	2000	4000	8000		
L _{WA} to supply inlet [dBA]	56	50	46	53	45	39	34	36	32		
L _{WA} to supply outlet [dBA]	64	56	52	63	52	39	38	43	35		
L _{WA} to exhaust inlet [dBA]	56	52	46	53	45	38	34	36	31		
L _{WA} to exhaust outlet [dBA]	64	58	53	62	51	40	38	42	33		
L _{WA} to environment [dBA]	49	45	40	44	38	33	29	27	22	28	38

Data provided for point 1 of the air flow diagram

Point	Total power of the unit [W]	Sound pressure level at 3 m (1 m) [dBA]
1	177	28 (38)
2	175	27 (37)
3	170	27 (37)
4	71	23 (33)
5	71	22 (32)
6	69	22 (32)
7	21	15 (25)
8	21	14 (24)
9	21	14 (24)

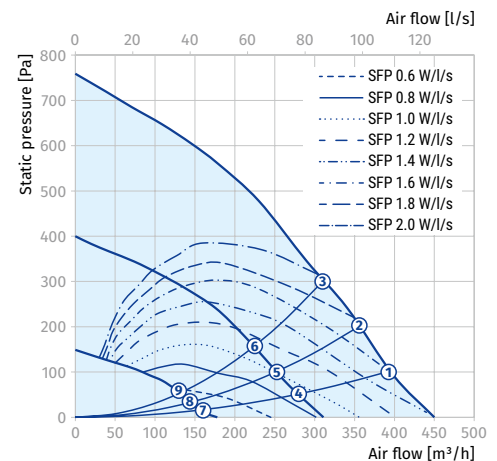

KOMFORT EC SB 350

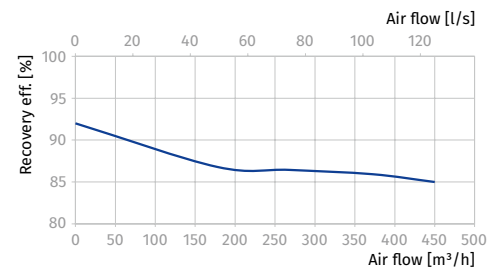

KOMFORT EC SB 350-E

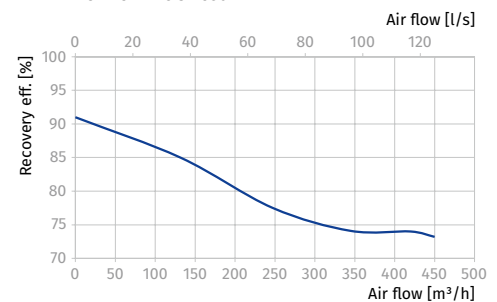

KOMFORT EC SB 350

Parameters	KOMFORT EC SB 550 S21 KOMFORT EC SB 550 S14	KOMFORT EC SB 550-E S21 KOMFORT EC SB 550-E S14
Supply voltage [V / 50 (60) Hz]	1~ 230	1~ 230
Power [W]	337	337
Current [A]	2.4	2.4
Maximum air flow [m³/h (l/s)]	690 (192)	690 (192)
RPM [min⁻¹]	2860	2860
Sound pressure level at a distance of 3 m [dBA]	26	26
Transported air temperature [°C]	-25...+40	-25...+40
Casing material	polymer-coated steel	polymer-coated steel
Insulation	40 mm mineral wool	40 mm mineral wool
Extract filter	G4	G4
Supply filter	F7 (option: G4)	F7 (option: G4)
Connected air duct diameter [mm]	200	200
Weight [kg]	82	82
Heat recovery efficiency [%]	84–92	73–91
Heat exchanger type	counter-flow	counter-flow
Heat exchanger material	polystyrene	enthalpy
SEC class	A+	A
ErP	2016, 2018	2016, 2018

KOMFORT EC SB 550(-E)

Sound power level, A-weighted	Total	Octave frequency band [Hz]								LpA 3 m	LpA 1 m
		63	125	250	500	1000	2000	4000	8000		
LWA to supply inlet [dBA]	54	47	42	50	44	41	39	39	31		
LWA to supply outlet [dBA]	69	63	56	65	59	55	50	52	46		
LWA to exhaust inlet [dBA]	54	47	41	51	43	33	31	34	30		
LWA to exhaust outlet [dBA]	65	61	50	61	55	46	43	46	40		
LWA to environment [dBA]	47	42	37	43	36	31	28	26	21	26	36

Data provided for point 1 of the air flow diagram

Point	Total power of the unit [W]	Sound pressure level at 3 m (1 m) [dBA]
1	337	26 (36)
2	337	26 (36)
3	337	25 (35)
4	118	24 (34)
5	113	24 (34)
6	107	22 (32)
7	34	15 (25)
8	66	14 (24)
9	32	13 (23)

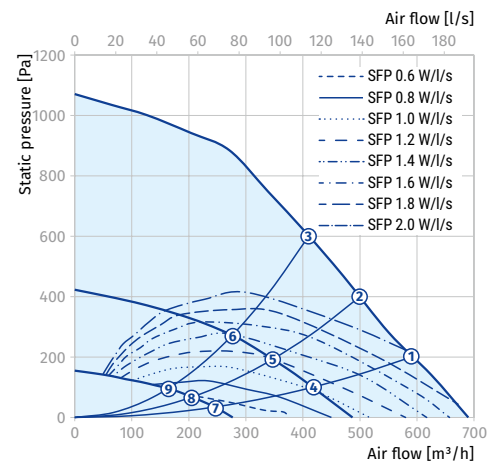



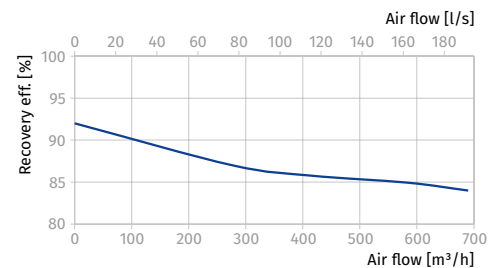



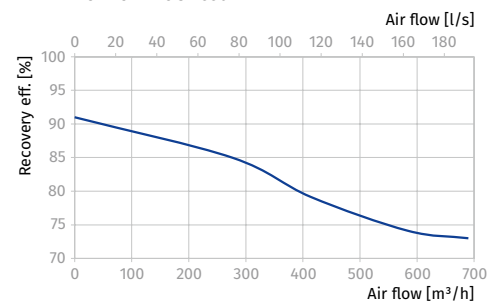













KOMFORT EC SB 550























KOMFORT EC SB 550-E























Accessories

		KOMFORT EC S 160(-E) S21	KOMFORT EC S 160(-E) S14	KOMFORT EC SB 160(-E) S21
G3 panel filter		–	–	–
G4 panel filter		FP 285x195x10 G4	FP 285x195x10 G4	FP 285x195x10 G4
F7 panel filter		FP 285x195x10 F7	FP 285x195x10 F7	FP 285x195x10 F7
Control panel		S22	–	S22
Wireless control panel		S22 Wi-Fi	–	S22 Wi-Fi
LCD control panel		S25	–	S25
Humidity sensor		FS2	FS2	FS2
CO ₂ sensor with indication		CD-1	CD-1	CD-1
CO ₂ sensor		CD-2	CD-2	CD-2
Humidity sensor		HR-S	HR-S	HR-S
VOC sensor		DPWQ30600	–	DPWQ30600
CO ₂ sensor		DPWQ40200	–	DPWQ40200
Humidity sensor		DPWC11200	–	DPWC11200
Kitchen exhaust hood		DAH 251-13	DAH 251-13	DAH 251-13
Electric preheater		EVH 125	–	EVH 125
Electric reheater		ENH 125	–	ENH 125
Syphon kit (for the units without an enthalpy heat exchanger)		SFK 20x32	SFK 20x32	SFK 20x32
Air damper		VKA 125	VKA 125	VKA 125
Electric actuator		LF230	LF230	LF230
Summer block		SB C6 366/285	SB C6 366/285	–

		KOMFORT EC SB 160(-E) S14	KOMFORT EC S 200(-E) S14	KOMFORT EC SB 200(-E) S14
G3 panel filter		–	FP 264x195x18 G3	FP 264x195x18 G3
G4 panel filter		FP 285x195x10 G4	–	–
F7 panel filter		FP 285x195x10 F7	–	–
Control panel		–	–	–
Wireless control panel		–	–	–
LCD control panel		–	–	–
Humidity sensor		FS2	FS2	FS2
CO ₂ sensor with indication		CD-1	CD-1	CD-1
CO ₂ sensor		CD-2	CD-2	CD-2
Humidity sensor		HR-S	HR-S	HR-S
VOC sensor		–	–	–
CO ₂ sensor		–	–	–
Humidity sensor		–	–	–
Kitchen exhaust hood		DAH 251-13	DAH 251-13	DAH 251-13
Electric preheater		–	–	–
Electric reheater		–	–	–
Syphon kit (for the units without an enthalpy heat exchanger)		SFK 20x32	SFK 20x32	SFK 20x32
Air damper		VKA 125	VKA 125	VKA 125
Electric actuator		LF230	LF230	LF230
Summer block		–	SB C6 366/240	–

		KOMFORT EC S 250(-E) S14	KOMFORT EC SB 250(-E) S21	KOMFORT EC SB 250(-E) S14
G3 panel filter		–	–	–
G4 panel filter		FP 417x200x18 G4	FP 417x200x18 G4	FP 417x200x18 G4
F7 panel filter		FP 417x184x18 F7	FP 417x184x18 F7	FP 417x184x18 F7
Control panel		–	S22	–
Wireless control panel		–	S22 Wi-Fi	–
LCD control panel		–	S25	–
Humidity sensor		FS2	FS2	FS2
CO ₂ sensor with indication		CD-1	CD-1	CD-1
CO ₂ sensor		CD-2	CD-2	CD-2
Humidity sensor		HR-S	HR-S	HR-S
VOC sensor		–	DPWQ30600	–
CO ₂ sensor		–	DPWQ40200	–
Humidity sensor		–	DPWC11200	–
Kitchen exhaust hood		DAH 251-13	DAH 251-13	DAH 251-13
Electric preheater		–	EVH 160	–
Electric reheater		–	ENH 160	–
Syphon kit (for the units without an enthalpy heat exchanger)		SFK 20x32	SFK 20x32	SFK 20x32
Air damper		VKA 160	VKA 160	VKA 160
Electric actuator		LF230	LF230	LF230
Summer block		SB C6 366/384	–	–

		KOMFORT EC SB 350(-E) S21	KOMFORT EC SB 350(-E) S14	KOMFORT EC SB 550(-E) S21	KOMFORT EC SB 550(-E) S14
G3 panel filter		–	–	–	–
G4 panel filter		FP 500x196x40 G4	FP 500x196x40 G4	FP 630x198x40 G4	FP 630x198x40 G4
F7 panel filter		FP 500x196x40 F7	FP 500x196x40 F7	FP 630x198x40 F7	FP 630x198x40 F7
Control panel		S22	–	S22	–
Wireless control panel		S22 Wi-Fi	–	S22 Wi-Fi	–
LCD control panel		S25	–	S25	–
Humidity sensor		FS2	FS2	FS2	FS2
CO ₂ sensor with indication		CD-1	CD-1	CD-1	CD-1
CO ₂ sensor		CD-2	CD-2	CD-2	CD-2
Humidity sensor		HR-S	HR-S	HR-S	HR-S
VOC sensor		DPWQ30600	–	DPWQ30600	–
CO ₂ sensor		DPWQ40200	–	DPWQ40200	–
Humidity sensor		DPWC11200	–	DPWC11200	–
Kitchen exhaust hood		DAH 251-13	DAH 251-13	DAH 251-13	DAH 251-13
Electric preheater		EVH 160	–	EVH 200	–
Electric reheater		ENH 160	–	ENH 200	–
Syphon kit (for the units without an enthalpy heat exchanger)		SFK 20x32	SFK 20x32	SFK 20x32	SFK 20x32
Air damper		VKA 160	VKA 160	VKA 200	VKA 200
Electric actuator		LF230	LF230	LF230	LF230
Summer block		–	–	–	–

KOMFORT EC DB

Suspended heat recovery air handling units

Features

- Air handling units for efficient supply and exhaust ventilation in flats, houses, cottages and other buildings.
- Heat recovery minimises ventilation heat losses.
- Controllable air exchange for creating the best suitable indoor microclimate.
- Compatible with round Ø 125 and 160 mm air ducts.



Air flow:
up to 410 m³/h
114 l/s



Heat recovery efficiency:
up to 98 %



Design

- The casing is made of double-skinned aluzinc panels, internally filled with 40 mm mineral wool layer for heat and sound insulation.
- The panel of the casing ensures easy access to the internals for cleaning and other maintenance operations.
- The spigots for connection to the air ducts are located at the sides of the unit and are rubber sealed for airtight connection to the air ducts.

Fans

- High-efficient external rotor EC motors and centrifugal impellers with backward curved blades are used for air supply and exhaust.
- EC motors have the best power consumption to air flow ratio and meet the latest demands concerning energy saving and high-efficient ventilation.

- EC motors are featured with high performance, low noise level and totally controllable speed range.
- Dynamically balanced impellers.

Bypass

- The units are equipped with the 100 % bypass for summer ventilation (room cooling by the cool intake air).

Air filtration

- The built-in F7 filter provides efficient supply air filtration.
- The G4 filter is used for extract air filtration.

HEAT RECOVERY AIR HANDLING UNITS

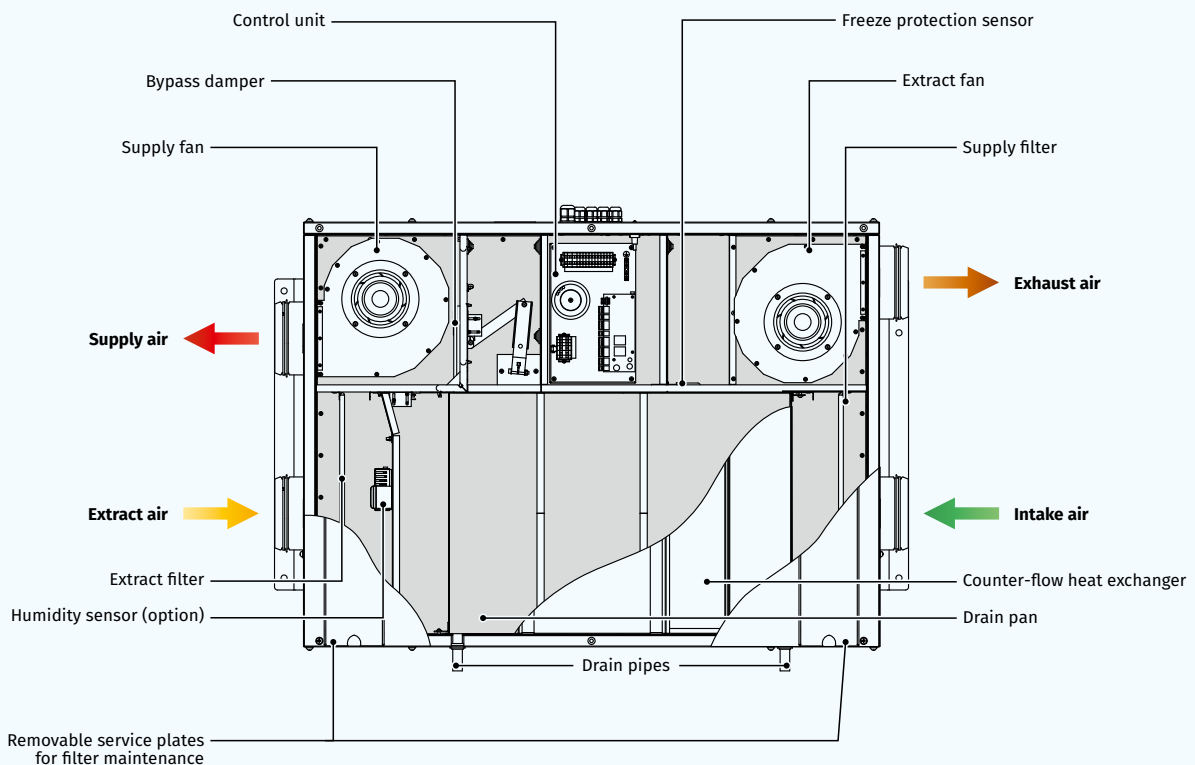

Heat recovery

- The unit is equipped with a plate counter-flow aluminium heat exchanger for heat recovery. The unit condensate is collected and drained to the drain pan under the heat exchanger.
- The air flows are completely separated in the heat exchanger. Thus smells and contaminants are not transferred from the extract air to the supply air.
- Heat recovery is based on heat and/or humidity transfer through the heat exchanger plates. In the cold season supply air is heated in the heat exchanger by transferring the heat energy of warm and humid extract air to the cold fresh air. Heat recovery minimizes ventilation heat losses and heating costs respectively.
- In the warm season the heat exchanger performs reverse and intake air is cooled in the heat exchanger by the cool extract air. That reduces operation load on air conditioners and saves electricity.



Control and automation

- The **KOMFORT EC DB S21** units are equipped with an integrated automation system. The remote control panel is not included in the delivery set (available separately).
- The S21 controller allows integrating the unit into the **Smart Home** system or **BMS (Building Management System)**.
- The unit can be controlled by the **Blauberg AHU** mobile application via Wi-Fi.



Download the **Blauberg AHU** app for Android



Download the **Blauberg AHU** app for iOS

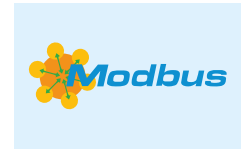





- The **KOMFORT EC DB S14** units have an integrated automation system with a wall-mounted control panel S14 with a LED indication.

Mounting

- The units are designed for ceiling or wall mounting.
- The mounting place must provide enough space for connection to drain system and condensate drainage using the SFK 20x32 kit (available separately).

Automation functions

Functions	KOMFORT EC DB S21	KOMFORT EC DB S14
Unit control via Wi-Fi using a mobile application	+	-
Unit control via a wired remote control panel	S22 control panel (option) 	S14 control panel 
Unit control via a wireless remote control panel	S22 Wi-Fi control panel (option) 	-
Unit control via a remote wired LCD control panel	S25 control panel (option) 	-
BMS (Building Management System)	RS-485	-
	Wi-Fi	-
	Ethernet	-
	MODBUS (RTU, TCP)	-
Blauberg Cloud Server service	+	-
Speed selection	+	+
Filter replacement indication	by filter timer	by filter timer
	by filter clogging differential pressure switch	-
Alarm indication	full alarm description in the mobile application	LED alarm indication
Week-scheduled operation	+	-
Bypass	automatic	-
	manual	manual
Timer	+	-
Boost mode	+	-
Fireplace mode	+	-
Freeze protection	through cyclic stops of the supply fan	through cyclic stops of the supply fan
	through preheating (option)	-
Reheater connection	option	-
Cooler connection	option	-
Minimum supply air temperature control	+	-
Humidity control	option	option
CO ₂ control	option	option
VOC control	option	-
PM2.5 control	option	-
Fire alarm sensor connection	option	option

Option: function is available when purchasing the appropriate accessory (see the "Accessories" section).

Designation key

Series	Motor type	Mounting type	Bypass	Rated air flow [m³/h]	Service side	Control
KOMFORT	EC: electronically commutated motor	D: suspended mounting, horizontally directed spigots	B: integrated bypass	160; 250; 350	R: right L: left	S21 S14

Overall dimensions [mm]

Model	D	B	H	H1	L
KOMFORT EC DB 160 S21/S14	125	754	320	361	1008
KOMFORT EC DB 250 S21/S14	125	754	320	361	1008
KOMFORT EC DB 350 S21/S14	160	1044	320	363	1138

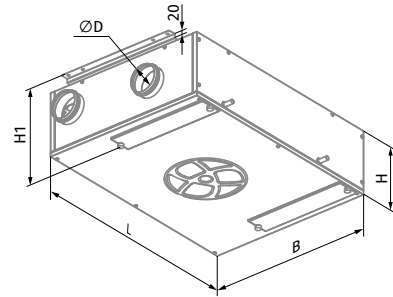

Technical data

Parameters	KOMFORT EC DB 160 S21 KOMFORT EC DB 160 S14	KOMFORT EC DB 250 S21 KOMFORT EC DB 250 S14	KOMFORT EC DB 350 S21 KOMFORT EC DB 350 S14
Voltage [V / 50 (60) Hz]	1 ~ 230	1 ~ 230	1 ~ 230
Power [W]	50	101	170
Current [A]	0.4	0.8	1.3
Maximum air flow [m³/h (l/s)]	190 (53)	270 (75)	410 (114)
RPM [min⁻¹]	3770	4480	3200
Sound pressure level at 3 m [dBA]	26	28	34
Transported air temperature [°C]	-25...+40	-25...+40	-25...+40
Casing material	galvanized steel	galvanized steel	galvanized steel
Insulation	40 mm mineral wool	40 mm mineral wool	40 mm mineral wool
Extract filter	G4	G4	G4
Supply filter	F7	F7	F7
Connected air duct diameter [mm]	125	125	160
Weight [kg]	48	48	70
Heat recovery efficiency [%]	82-94	80-98	80-91
Heat exchanger type	counter-flow	counter-flow	counter-flow
Heat exchanger material	polystyrene	polystyrene	polystyrene
SEC class	A+	A	A
ErP	2016, 2018	2016, 2018	2016, 2018

KOMFORT EC DB 160

Sound power level, A-weighted	Total	Octave frequency band [Hz]								LpA 3 m	LpA 1 m
		63	125	250	500	1000	2000	4000	8000		
LWA to supply inlet [dBA]	53	32	45	50	45	38	34	36	29		
LWA to supply outlet [dBA]	61	36	51	60	52	38	39	41	33		
LWA to exhaust inlet [dBA]	53	33	45	50	45	38	34	35	31		
LWA to exhaust outlet [dBA]	61	37	51	59	54	41	40	41	33		
LWA to environment [dBA]	47	29	41	44	37	34	28	27	23	26	36

Data provided for point 1 of the air flow diagram

Point	Total power of the unit [W]	Sound pressure level at 3 m (1 m) [dBA]
1	49	26 (36)
2	49	26 (36)
3	48	25 (35)
4	21	22 (32)
5	21	22 (32)
6	20	21 (31)
7	8	19 (29)
8	8	18 (28)
9	8	18 (28)

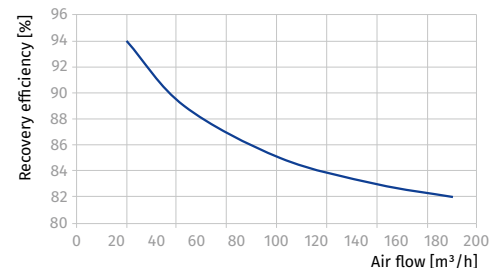
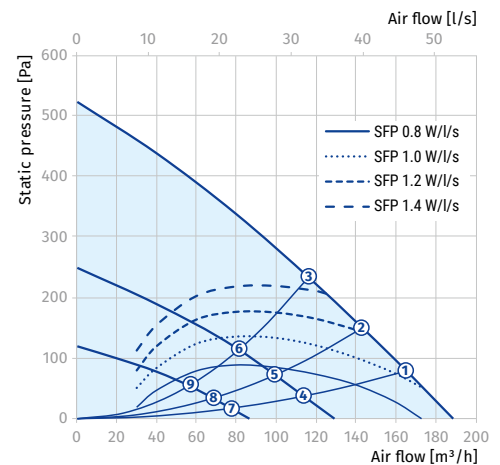

KOMFORT EC DB 250

Sound power level, A-weighted	Total	Octave frequency band [Hz]								LpA 3 m	LpA 1 m
		63	125	250	500	1000	2000	4000	8000		
L _{WA} to supply inlet [dBA]	55	51	45	51	44	37	33	35	30		
L _{WA} to supply outlet [dBA]	65	59	54	63	52	41	39	43	34		
L _{WA} to exhaust inlet [dBA]	55	50	45	51	44	37	33	35	31		
L _{WA} to exhaust outlet [dBA]	66	57	53	64	53	39	38	43	35		
L _{WA} to environment [dBA]	49	45	40	44	38	33	29	27	22	28	38

Data provided for point 1 of the air flow diagram

Point	Total power of the unit [W]	Sound pressure level at 3 m (1 m) [dBA]
1	100	28 (38)
2	99	27 (37)
3	98	27 (37)
4	55	23 (33)
5	54	22 (32)
6	54	22 (32)
7	17	15 (25)
8	17	14 (24)
9	16	14 (24)

KOMFORT EC DB 350







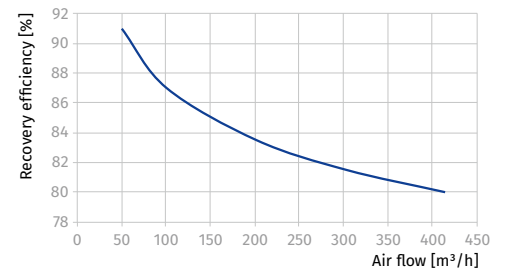
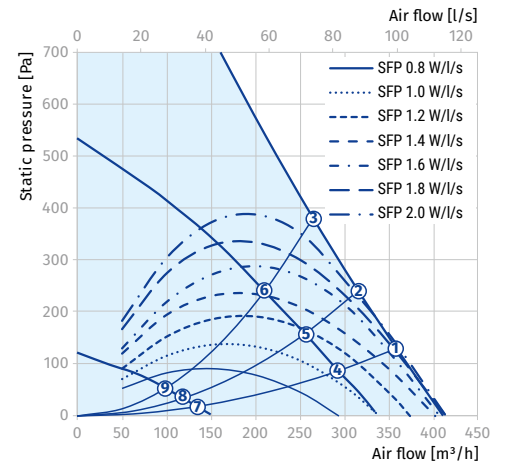
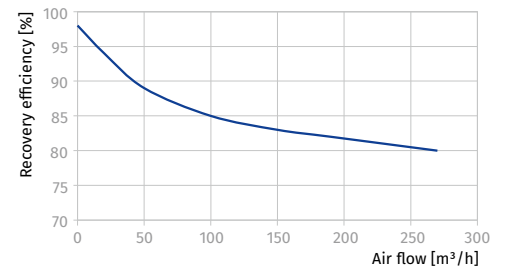
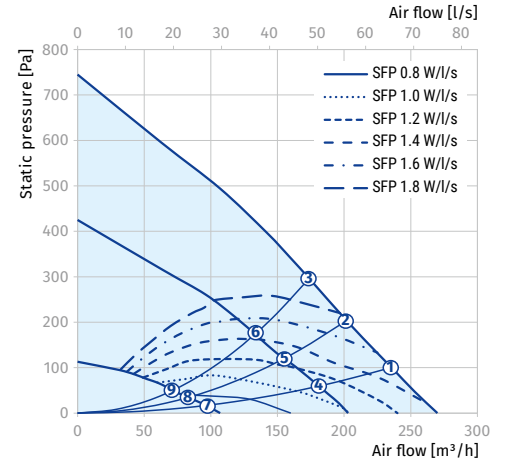











Sound power level, A-weighted	Total	Octave frequency band [Hz]								LpA 3 m	LpA 1 m
		63	125	250	500	1000	2000	4000	8000		
L _{WA} to supply inlet [dBA]	60	46	54	58	50	46	40	40	31		
L _{WA} to supply outlet [dBA]	63	52	58	60	54	46	40	41	35		
L _{WA} to exhaust inlet [dBA]	61	47	54	58	50	47	41	41	32		
L _{WA} to exhaust outlet [dBA]	63	51	58	59	56	46	40	41	35		
L _{WA} to environment [dBA]	55	44	51	51	43	38	32	28	24	34	44



















Data provided for point 1 of the air flow diagram

Point	Total power of the unit [W]	Sound pressure level at 3 m (1 m) [dBA]
1	169	34 (44)
2	169	34 (44)
3	169	33 (43)
4	87	28 (38)
5	86	28 (38)
6	84	27 (37)
7	20	22 (32)
8	19	22 (32)
9	19	21 (31)



Accessories

		KOMFORT EC DB 160 S21	KOMFORT EC DB 160 S14	KOMFORT EC DB 250 S21	KOMFORT EC DB 250 S14
G4 panel filter		FP 403x253x48 G4	FP 403x253x48 G4	FP 403x253x48 G4	FP 403x253x48 G4
F7 panel filter		FP 403x253x48 F7	FP 403x253x48 F7	FP 403x253x48 F7	FP 403x253x48 F7
Control panel		S22	-	S22	-
Wireless control panel		S22 Wi-Fi	-	S22 Wi-Fi	-
LCD control panel		S25	-	S25	-
Humidity sensor		FS2	FS2	FS2	FS2
Humidity sensor		HR-S	HR-S	HR-S	HR-S
Humidity sensor		DPWC11200	-	DPWC11200	-
CO ₂ sensor with indication		CD-1	CD-1	CD-1	CD-1
CO ₂ sensor		CD-2	CD-2	CD-2	CD-2
CO ₂ sensor		DPWQ40200	-	DPWQ40200	-
VOC sensor		DPWQ30600	-	DPWQ30600	-
Electric preheater		EVH 125	-	EVH 125	-
Electric reheater		ENH 125	-	ENH 125	-
Syphon kit		SFK 20x32	SFK 20x32	SFK 20x32	SFK 20x32
Silencer		SD 125	SD 125	SD 125	SD 125
Air damper		VKA 125	VKA 125	VKA 125	VKA 125
Electric actuator		LF230	LF230	LF230	LF230

		KOMFORT EC DB 350 S21	KOMFORT EC DB 350 S14
G4 panel filter		FP 603x253x48 G4	FP 603x253x48 G4
F7 panel filter		FP 603x253x48 F7	FP 603x253x48 F7
Control panel		S22	-
Wireless control panel		S22 Wi-Fi	-
LCD control panel		S25	-
Humidity sensor		FS2	FS2
Humidity sensor		HR-S	HR-S
Humidity sensor		DPWC11200	-
CO ₂ sensor with indication		CD-1	CD-1
CO ₂ sensor		CD-2	CD-2
CO ₂ sensor		DPWQ40200	-
VOC sensor		DPWQ30600	-
Electric preheater		EVH 160	-
Electric reheater		ENH 160	-
Syphon kit		SFK 20x32	SFK 20x32
Silencer		SD 160	SD 160
Air damper		VKA 160	VKA 160
Electric actuator		LF230	LF230

KOMFORT ERV EC DB

Suspended heat and energy recovery air handling units

Features

- Air handling units for efficient supply and exhaust ventilation in flats, houses, cottages and other buildings.
- Reduction of load on air conditioning systems in a hot climate and heat loss in a cold climate due to heat and moisture recovery.
- Control of air exchange for creating comfortable indoor microclimate.
- Compatible with round Ø 100 or 150 mm air ducts.



Air flow:
up to 430 m³/h
119 l/s



Heat recovery efficiency:
up to 85 %



Design

- The casing is made of polymer-coated steel panels, internally filled with foamed polyurethane layer 5–10 mm (depend on modification) for heat- and sound-insulation.
- The unit is equipped with a removable bottom panel for ease of maintenance. This service panel is used to access the filters and the heat exchanger for maintenance operations.
- The spigots are located at the sides of the unit and are equipped with rubber seals for airtight connection to the air ducts.
- The casing is equipped with fixing brackets to suspend the unit to the ceiling.

Fans

- The unit is equipped with high-efficient external rotor EC motors used for air supply and exhaust.
- The **KOMFORT ERV EC DB 100 S14**, **KOMFORT ERV EC DB 150 S14** and **KOMFORT ERV EC DB 250 S14** units are equipped with a centrifugal impeller with forward curved blades and the **KOMFORT ERV EC DB 350 S14** units – with backward curved blades.
- EC motors have the best power consumption to air flow ratio and meet the latest demands concerning energy saving and high-efficient ventilation.
- EC motors are featured with high performance, low noise level and totally controllable speed range.
- The impellers are dynamically balanced.

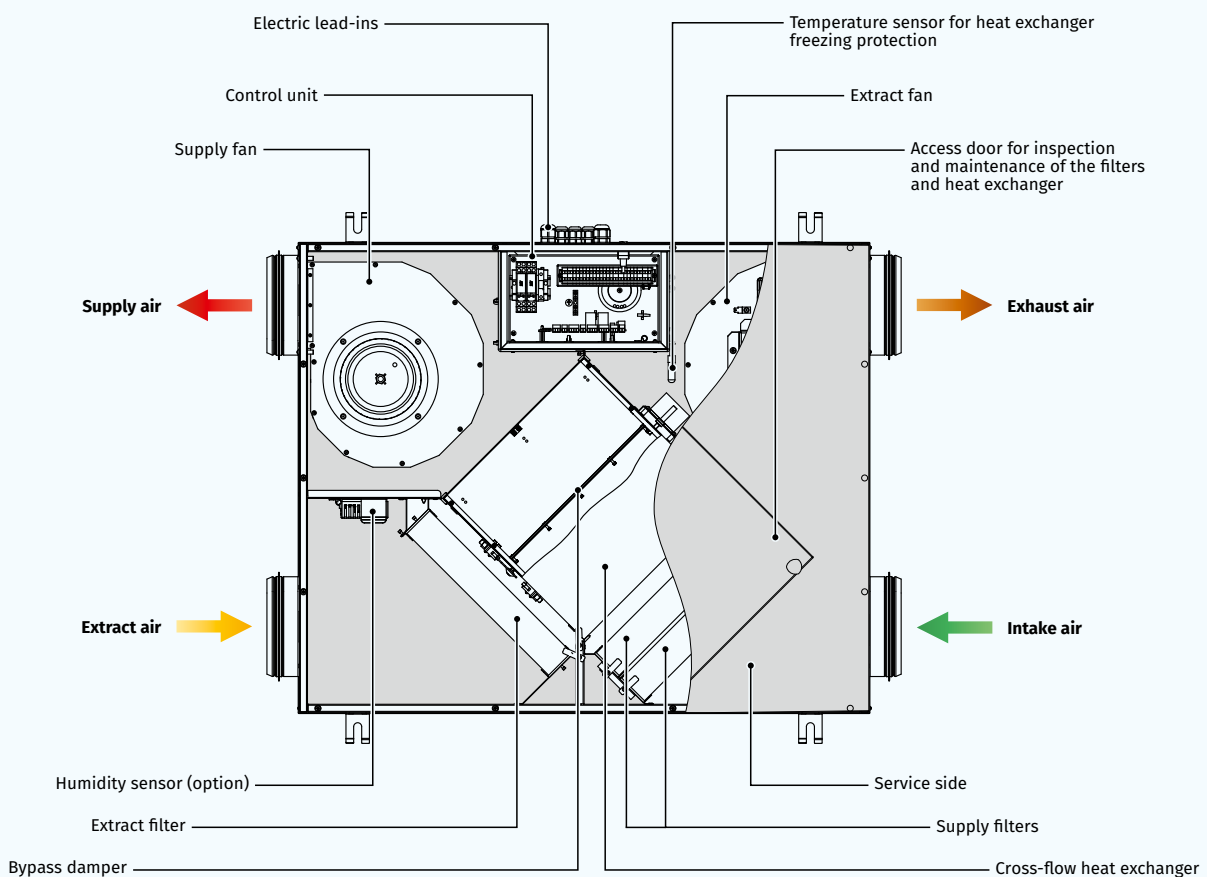

Heat recovery

- The unit is equipped with an enthalpy plate cross-flow heat exchanger for energy (heat and humidity) recovery. Due to humidity recovery condensate is not generated in the enthalpy heat exchanger.



- The air flows are completely separated in the heat exchanger. Thus smells and contaminants are not transferred from the extract air to the supply air.
- Heat recovery is based on heat and/or humidity transfer through the heat exchanger plates. In the cold season supply air is heated in the heat exchanger by transferring the heat energy of warm and humid extract air to the cold fresh air. Heat recovery minimizes ventilation heat losses and heating costs respectively.
- In the warm season the heat exchanger performs reverse and intake air is cooled in the heat exchanger by the cool extract air. That reduces operation load on air conditioners and saves electricity.

FROST PROTECTION

- The integrated automatic freeze protection is used to prevent freezing of the heat exchanger in the cold season. The supply fan turns off according to the temperature sensor to get the heat exchanger warmed up with extract air. After that the supply fan turns on and the unit continues to run in the standard mode.

Air filtration

- Two built-in G4 and F8 filters provide efficient supply air filtration.
- The G4 filter is used for extract air filtration.

Bypass

- The units are equipped with a bypass for summer ventilation (air cooling by the cool air from outside).

Designation key

Series	Unit type	Motor type	Mounting type	Bypass	Rated air flow [m³/h]	Service side	Control
KOMFORT	ERV: energy recovery ventilation	EC: electronically commutated motor	D: suspended mounting, horizontally directed spigots	B: integrated bypass	100; 150; 250; 350	R: right L: left	S14: sensor control panel with LED indication

Overall dimensions [mm]

Model	D	B	H	L	L1
KOMFORT ERV EC DB 100 S14	100	481	204	600	734
KOMFORT ERV EC DB 150 S14	100	704	222	854	987
KOMFORT ERV EC DB 250 S14	150	704	227	854	987
KOMFORT ERV EC DB 350 S14	150	754	277	1024	1157

Control and automation

- The **KOMFORT ERV EC DB S14** units have an with a wall-mounted control panel S14 with a LED indication. The units are equipped with a USB connector (Type B) and can be connected to a PC for configuring the advanced settings in a special software.
- The standard delivery set includes a 10 m cable for connection of the unit to the control panel.
- S14 automation functions:**
 - Unit On/Off.
 - Unit performance control (selection of Low, Medium or High speed).
 - Bypass damper opening and closing for summer ventilation.
 - Alarm indication.
 - Filter maintenance indication.
- Additional functions of the S14 automation with installed software:**
 - Fan speed adjustment from 0 to 100 %. Each speed is individually adjusted for the supply and the extract fans.
 - Operation control on feedback from the FS2 duct humidity sensor (to be ordered separately).
 - Unit operation setting according to the external control unit (to be ordered separately).
 - Temperature setting for freeze protection system activation.
 - Control and operation adjustment of the filter maintenance timer
 - External relay control unit and humidity level control.
 - Software version upgrading.



Mounting

- Due to a low casing height the air handling units are a perfect solution for space-restricted installation above suspended ceilings.
- The unit mounting position must provide access for service maintenance.

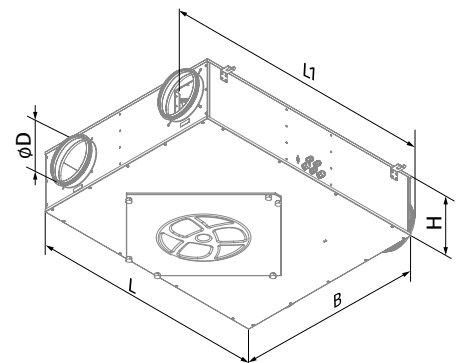

Technical data

Parameters	KOMFORT ERV EC DB 100 S14	KOMFORT ERV EC DB 150 S14	KOMFORT ERV EC DB 250 S14	KOMFORT ERV EC DB 350 S14
Voltage [V / 50 (60) Hz]	1~230	1 ~ 230	1 ~ 230	1 ~ 230
Power [W]	66	83	84	171
Current [A]	0.5	0.7	0.7	1.3
Maximum air flow [m ³ /h (l/s)]	170 (47)	215 (60)	300 (83)	430 (119)
RPM [min ⁻¹]	2800	2000	2000	3200
Sound pressure level at 3 m [dBA]	30	32	36	46
Transported air temperature [°C]	-25...+40	-25...+40	-25...+40	-25...+40
Extract filter	G4	G4	G4	G4
Supply filter	G4 + F8 (PM2.5 > 93 %)	G4 + F8 (PM2.5 > 93 %)	G4 + F8 (PM2.5 > 83 %)	G4 + F8 (PM2.5 > 87 %)
Connected air duct diameter [mm]	100	100	150	150
Weight [kg]	17	26	29	42
Heat recovery efficiency [%]*	70–82	68–82	63–73	68–85
Humidity recovery efficiency [%]	24–41	22–41	16–27	19–34
Heat exchanger type	cross-flow	cross-flow	cross-flow	cross-flow
Heat exchanger material	enthalpy	enthalpy	enthalpy	enthalpy
SEC class	A	A	A	A
ErP	2016, 2018	2016, 2018	2016, 2018	2016, 2018

*Heat recovery efficiency is specified in compliance with EN 13141-7.

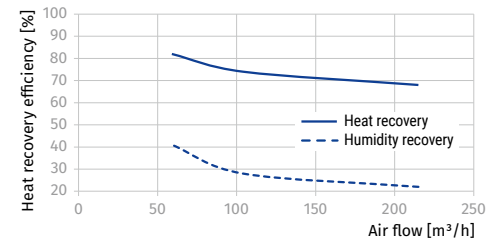
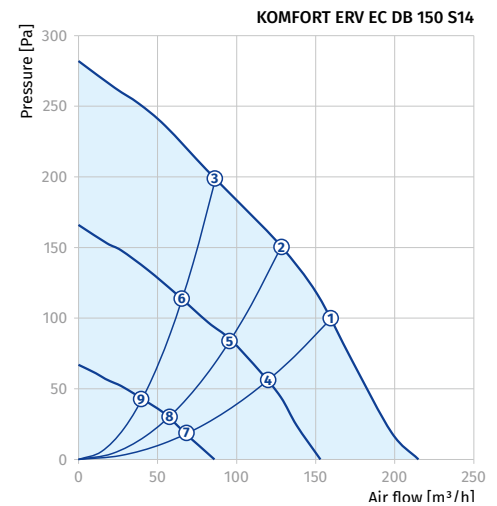
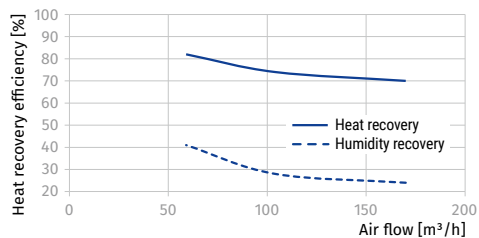
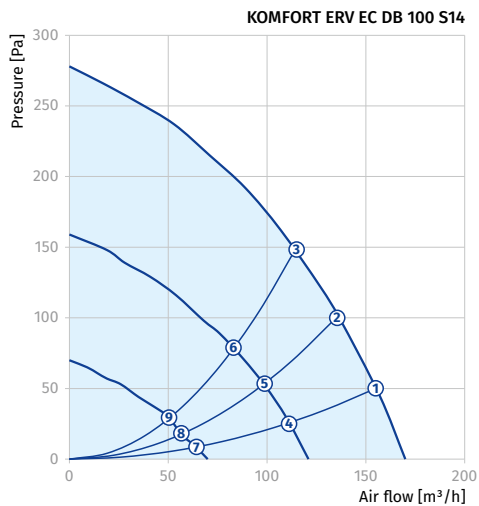
Total power of the unit [W]

Point	KOMFORT ERV EC DB 100 S14	KOMFORT ERV EC DB 150 S14	KOMFORT ERV EC DB 250 S14	KOMFORT ERV EC DB 350 S14
1	62	64	80	147
2	55	61	67	145
3	48	55	59	144
4	30	26	43	75
5	27	24	34	73
6	25	23	28	70
7	13	13	23	21
8	13	13	22	21
9	12	13	19	20

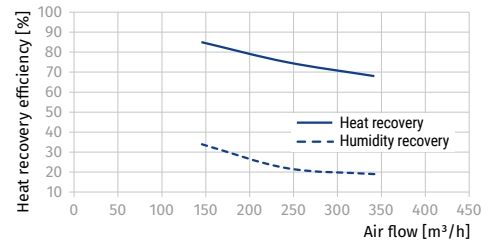
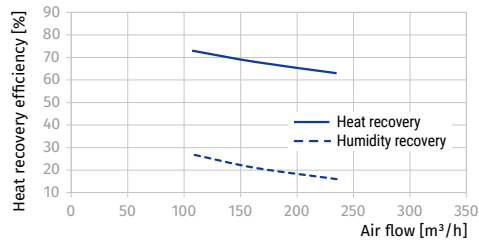
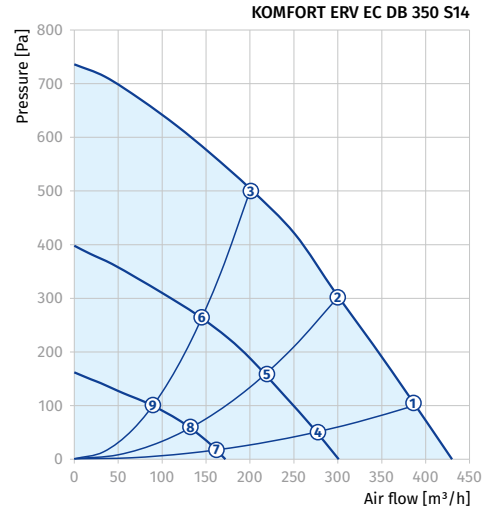
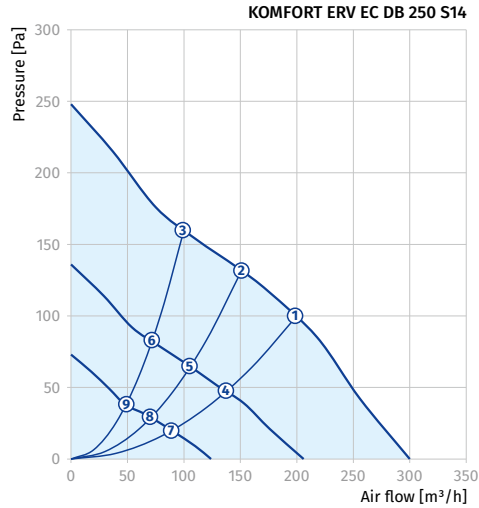

Accessories

		KOMFORT ERV EC DB 100 S14	KOMFORT ERV EC DB 150 S14	KOMFORT ERV EC DB 250 S14	KOMFORT ERV EC DB 350 S14
G4 panel filter		FP 200x191x20 G4	FP 300x220x48 G4	FP 300x220x48 G4	FP 300x270x48 G4
F8 panel filter		FP 200x191x40 F8	FP 300x220x48 F8	FP 300x220x48 F8	FP 300x270x48 F8
Humidity sensor		FS2	FS2	FS2	FS2
CO ₂ sensor with indication		CD-1	CD-1	CD-1	CD-1
CO ₂ sensor		CD-2	CD-2	CD-2	CD-2
Humidity sensor		HR-S	HR-S	HR-S	HR-S
Air damper		VKA 100	VKA 100	VKA 150	VKA 150
Electric actuator		LF230	LF230	LF230	LF230

KOMFORT ERV D S20

Suspended heat and energy recovery air handling units

Features

- Air handling unit for efficient supply and exhaust ventilation in flats, houses, cottages and other buildings.
- Heat and humidity recovery minimizes ventilation heat losses during cold season and reduce air conditioner load during hot season.
- Controllable air exchange ensures the best suitable indoor microclimate.
- Compatible with round Ø 100 or 150 mm air ducts.



Air flow:
up to 400 m³/h
111 l/s



Heat recovery efficiency:
up to 87 %



Design

- The casing is made of polymer coated steel panels, internally heat- and sound-insulated with 5–10 mm (depend on modification) polyurethane foam.
- The bottom service panel provides easy access for maintenance of the filters and the heat exchanger.
- The spigots for connection to the air ducts are located at the sides of the unit and are rubbed sealed for airtight connection to the air ducts.
- The mounting brackets on the casing ensure easy installation under the ceiling.

Fans

- Asynchronous motors are used for air supply and exhaust.
- The units are equipped with a centrifugal impeller with forward curved blades.
- Integrated overheating protection with automatic restart.
- Ball bearings for longer service life.
- Dynamically balanced impellers.
- Featured with reliable and low-noise operation.

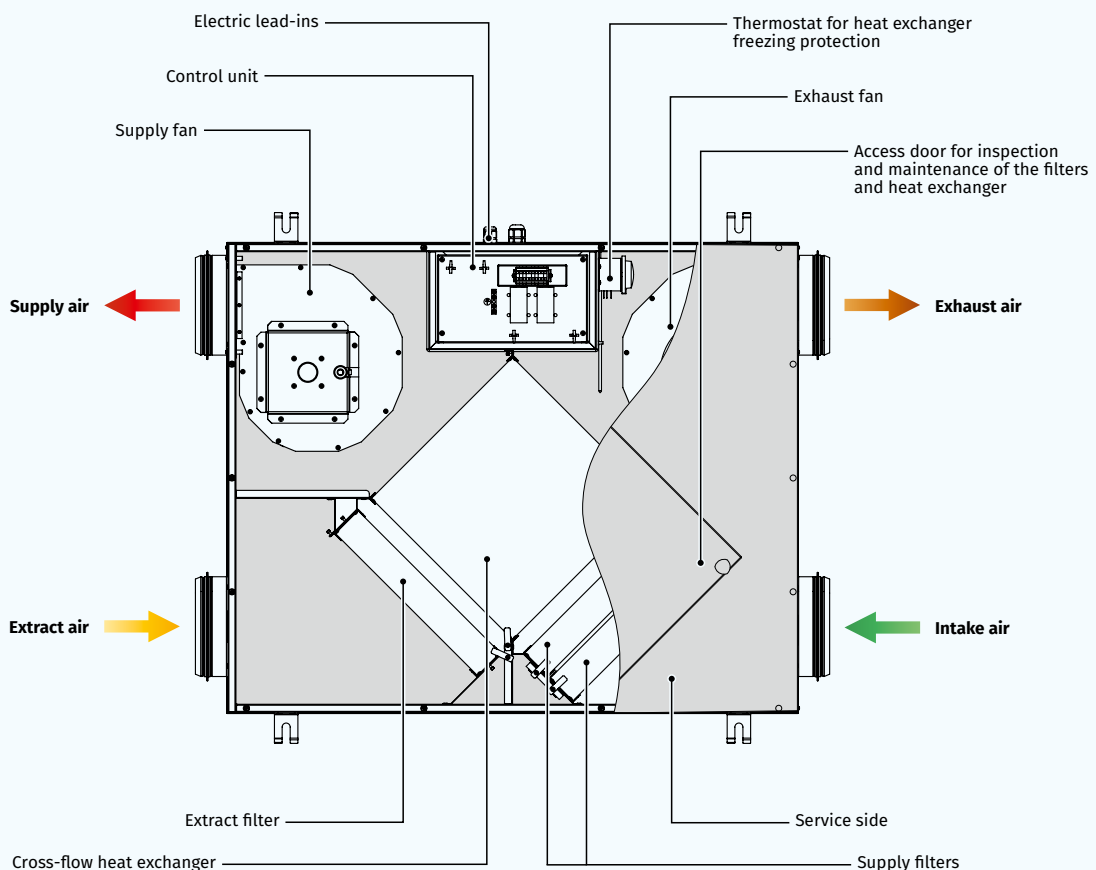

Heat recovery

- The unit is equipped with an enthalpy plate cross-flow heat exchanger for energy (heat and humidity) recovery. Due to humidity recovery condensate is not generated in the enthalpy heat exchanger.



- The air flows are completely separated in the heat exchanger. Thus smells and contaminants are not transferred from the extract air to the supply air.
- Heat recovery is based on heat and/or humidity transfer through the heat exchanger plates. In the cold season supply air is heated in the heat exchanger by transferring the heat energy of warm and humid extract air to the cold fresh air. Heat recovery minimizes ventilation heat losses and heating costs respectively.
- In the warm season the heat exchanger performs reverse and intake air is cooled in the heat exchanger by the cool extract air. That reduces operation load on air conditioners and saves electricity.

Control and automation

- Integrated control system based on triac speed controller CDT1 E.



Air filtration

- Two built-in G4 and F8 filters provide efficient supply air filtration.
- The G4 filter is used for extract air filtration.

Mounting

- Due to the low casing height the unit is the ideal solution for mounting in the limited space behind the suspended ceiling.
- The installation place must be easily accessible for servicing.

FROST PROTECTION

- The integrated automatic freeze protection is used to prevent freezing of the heat exchanger in the cold season. The supply fan turns off according to the temperature sensor to get the heat exchanger warmed up with extract air. After that the supply fan turns on and the unit continues to run in the standard mode.

Designation key

Series	Unit type	Mounting type	Rated air flow [m³/h]	Service side	Control
KOMFORT	ERV: energy recovery ventilation	D: suspended mounting, horizontally directed spigots	150; 250; 350	R: right L: left	S20: speed controller CDT1 E

Overall dimensions [mm]

Model	∅ D	B	H	L	L1
KOMFORT ERV D 150 S20	99	704	227	947	854
KOMFORT ERV D 250 S20	149	704	227	947	854
KOMFORT ERV D 350 S20	149	754	277	1117	1024

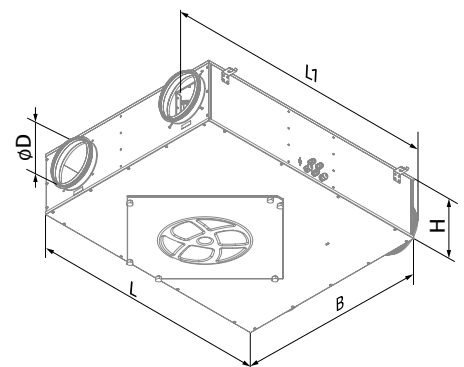

Technical data



Parameters	KOMFORT ERV D 150 S20	KOMFORT ERV D 250 S20	KOMFORT ERV D 350 S20
Voltage [V / 50 (60) Hz]	1 ~ 230	1 ~ 230	1 ~ 230
Power [W]	125	250	310
Current [A]	0.6	1.1	1.4
Maximum air flow [m ³ /h (l/s)]	230 (64)	370 (103)	400 (111)
RPM [min ⁻¹]	2235	2400	2150
Sound pressure level at 3 m [dBA]	49	52	57
Transported air temperature [°C]	-25...+40	-25...+40	-25...+40
Insulation [mm]	5 - 10	5 - 10	5 - 10
Extract filter	G4	G4	G4
Supply filter	G4 and F8 (PM2.5 93 %)	G4 and F8 (PM2.5 93 %)	G4 and F8 (PM2.5 93 %)
Connected air duct diameter [mm]	100	150	150
Weight [kg]	26	29	42
Heat recovery efficiency [%]*	72-87	66-76	71-87
Humidity recovery efficiency [%]	27-47	22-32	23-40
Heat exchanger type	cross-flow	cross-flow	cross-flow
Heat exchanger material	enthalpy	enthalpy	enthalpy
SEC class	D	E	E
ErP	2016	2016	2016

*Heat recovery efficiency is specified in compliance with EN 13141-7.

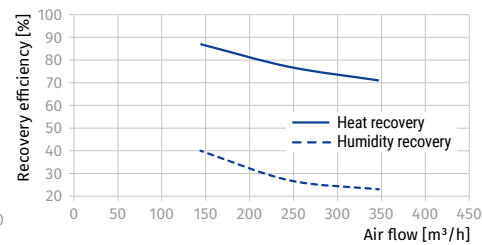
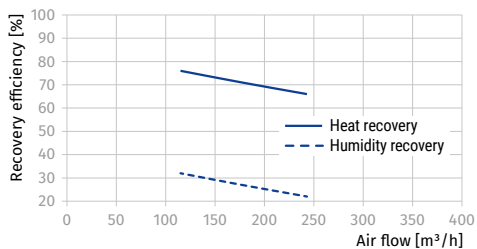
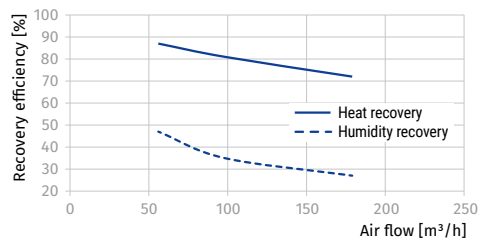
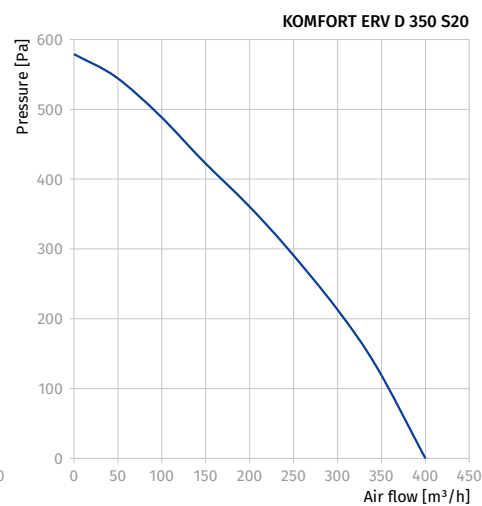
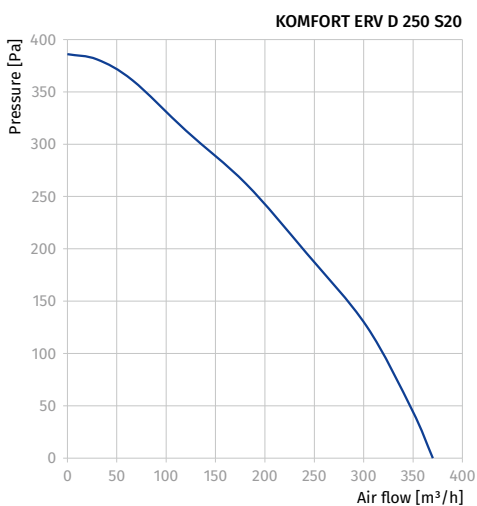
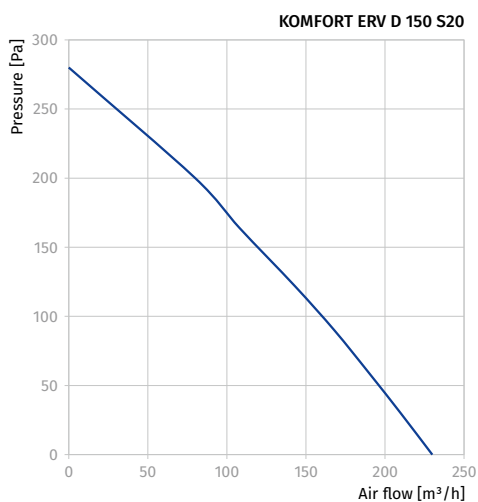
HEAT RECOVERY AIR HANDLING UNITS



Accessories

		KOMFORT ERV D 150 S20	KOMFORT ERV D 250 S20	KOMFORT ERV D 350 S20
G4 panel filter		FP 300x220x48 G4	FP 300x220x48 G4	FP 300x270x48 G4
F8 panel filter		FP 300x220x48 F8	FP 300x220x48 F8	FP 300x270x48 F8

KOMFORT ERV D S3/S4

Suspended energy recovery air handling units

Features

- Air handling units for efficient supply and exhaust ventilation in flats, houses, cottages and other buildings.
- Reduction of load for air conditioning systems in hot climate and heat losses in cold climate conditions due to heat and humidity recovery.
- Quality air exchange control for arrangement of comfortable indoor climate.
- Compatible with round Ø 100 or 150 mm air ducts.



Air flow:
up to 500 m³/h
139 l/s



Heat recovery efficiency:
up to 87 %



Design

- The casing is made of polymer-coated steel panels, internally filled with 5–10 mm thick expanded polyurethane layer.
- The bottom service panel is used to access the filters and the heat exchanger for maintenance operations.
- The spigots are located at the sides of the unit and are equipped with rubber seals for airtight connection to the air ducts.
- The casing is equipped with fixing brackets to suspend the unit to the ceiling.

Fans

- Asynchronous external rotor motors are used for air supply and exhaust.
- The units are equipped with single-phase three-speed external rotor motors with centrifugal impellers and forward curved blades.
- Integrated motor overheating protection with automatic restart.
- Ball bearings ensure long service life.
- The impellers are dynamically balanced.
- Featured with reliable and low-noise operation.

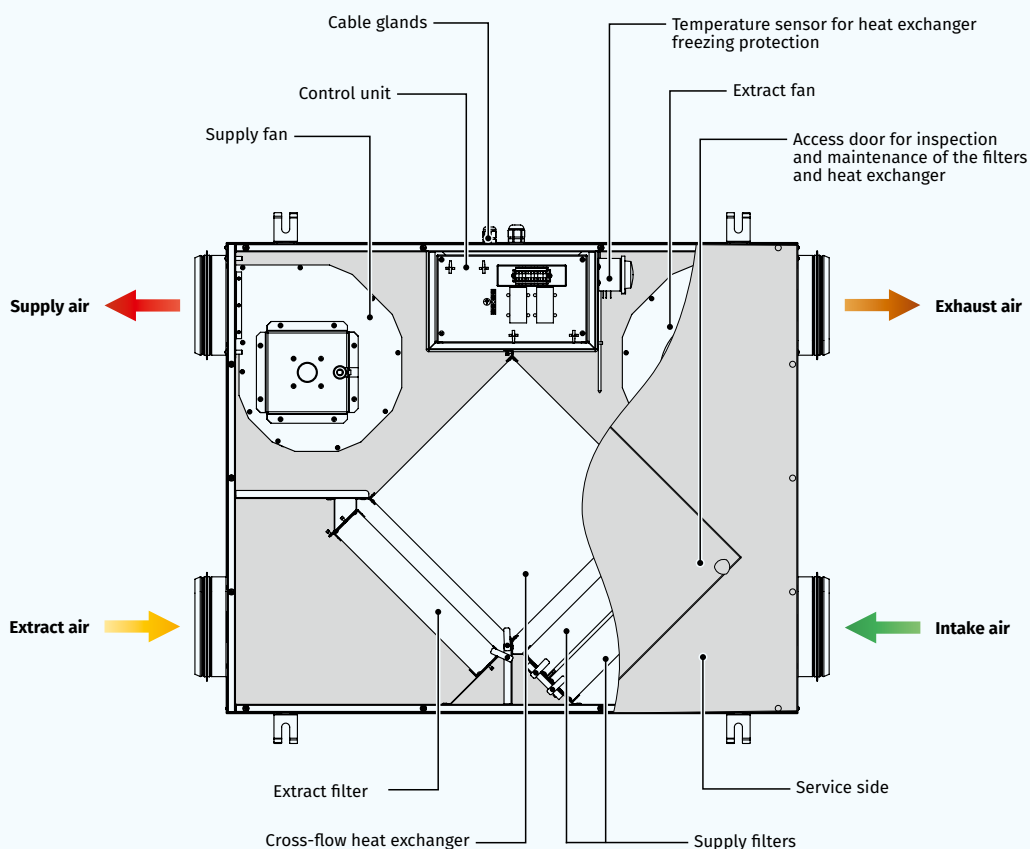

Air filtration

- Two built-in G4 and F8 filters provide efficient supply air filtration.
- The G4 filter is used for extract air filtration.

Heat recovery

- The unit is equipped with an enthalpy plate cross-flow heat exchanger for energy (heat and humidity) recovery. Due to humidity recovery condensate is not generated in the enthalpy heat exchanger.
- The air flows are completely separated in the heat exchanger. Thus smells and contaminants are not transferred from the extract air to the supply air.
- Heat recovery is based on heat and/or humidity transfer through the heat exchanger plates. In the cold season supply air is heated in the heat exchanger by transferring the heat energy of warm and humid extract air to the cold fresh air. Heat recovery minimizes ventilation heat losses and heating costs respectively.
- In the warm season the heat exchanger performs reverse and intake air is cooled in the heat exchanger by the cool extract air. That reduces operation load on air conditioners and saves electricity.
- When the indoor and outdoor temperature difference is insignificant, heat recovery is not reasonable. In this case the heat exchanger can be temporary replaced with a summer block for the warm season (available as a specially ordered accessory).



Control and automation

- The units have integrated control system based on the mechanical three-speed speed switch CDP-3/5 (**KOMFORT ERV D... S3**) or sensor three-speed speed switch SGR-3/1 (**KOMFORT ERV D... S4**), and power cable with mains plug.
- The control unit is integrated in the unit casing.
- The power and ground cables are connected to the control unit via the cable glands on the side of the unit.



Mounting

- Due to a low casing height the air handling units are a perfect solution for space-restricted installations above suspended ceilings.
- The unit mounting position must provide access for service maintenance.

FROST PROTECTION

- The integrated automatic freeze protection is used to prevent freezing of the heat exchanger in the cold season. The supply fan turns off according to the temperature sensor to get the heat exchanger warmed up with extract air. After that the supply fan turns on and the unit continues to run in the standard mode.

Designation key

Series	Unit type	Mounting type
KOMFORT	ERV: energy recovery unit	D: suspended mounting, horizontally directed spigots

Rated air flow [m³/h]	Service side	Control
100; 200; 300; 450	R: right L: left	S3: mechanical speed switch CDP-3/5 S4: sensor speed switch SGR-3/1

Overall dimensions [mm]

Model	∅ D	B	H	L
KOMFORT ERV D 100 S3/S4	100	481	203	600
KOMFORT ERV D 200 S3/S4	100	704	227	854
KOMFORT ERV D 300 S3/S4	150	704	227	854
KOMFORT ERV D 450 S3	150	704	227	1020

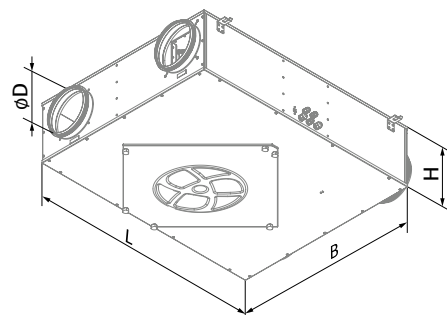

Technical data

Parameters	KOMFORT ERV D 100 S3 KOMFORT ERV D 100 S4	KOMFORT ERV D 200 S3 KOMFORT ERV D 200 S4
Voltage [V / 50 Hz]	1~230	1~230
Power [W]	76	141
Current [A]	0.33	0.63
Maximum air flow [m ³ /h (l/s)]	160 (44)	280 (78)
RPM [min ⁻¹]	2750	2840
Sound pressure level at 3 m [dBA]	47	49
Transported air temperature [°C]	-25...+40	-25...+40
Insulation	5–10 mm expanded polyurethane	5–10 mm expanded polyurethane
Extract filter	G4	G4
Supply filter	G4 and F8 (PM2.5 > 93 %)	G4 and F8 (PM2.5 > 93 %)
Connected air duct diameter [mm]	100	100
Weight [kg]	17	24
Heat recovery efficiency [%]*	75–87	72–87
Humidity recovery efficiency [%]	32–47	27–47
Heat exchanger type	cross-flow	cross-flow
Heat exchanger material	enthalpy	enthalpy
SEC class	D	D
ErP	2016	2016

*Heat recovery efficiency is specified in compliance with EN 13141-7.

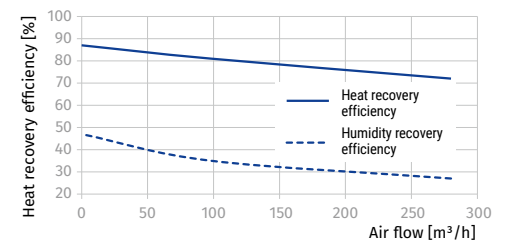
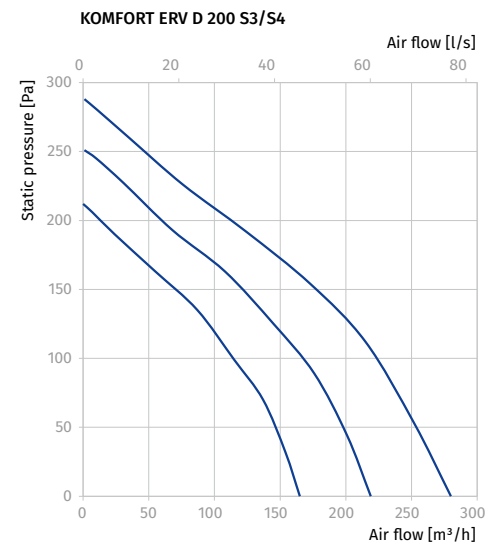
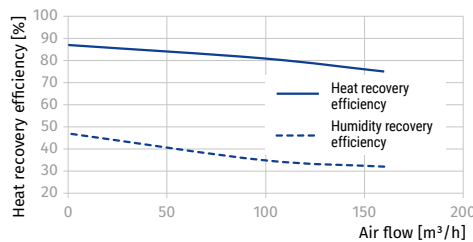
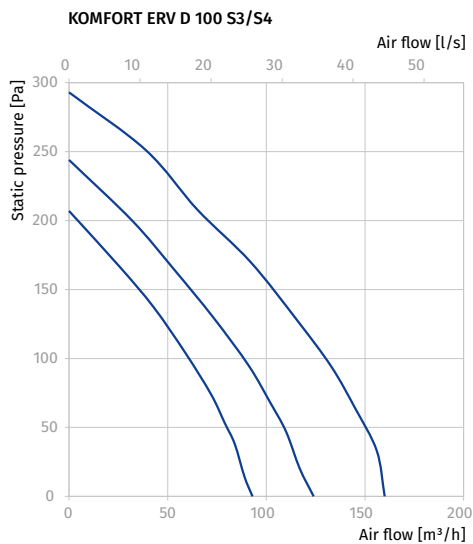

Parameters	KOMFORT ERV D 300 S3 KOMFORT ERV D 300 S4	KOMFORT ERV D 450 S3
Voltage [V / 50 Hz]	1~230	1~230
Power [W]	193	354
Current [A]	0.84	1.54
Maximum air flow [m³/h (l/s)]	340 (94)	500 (139)
RPM [min⁻¹]	2720	2870
Sound pressure level at 3 m [dBA]	52	57
Transported air temperature [°C]	-25...+40	-25...+40
Insulation	5–10 mm expanded polyurethane	5–10 mm expanded polyurethane
Extract filter	G4	G4
Supply filter	G4 and F8 (PM2.5 > 93 %)	G4 and F8 (PM2.5 > 93 %)
Connected air duct diameter [mm]	150	150
Weight [kg]	27	39
Heat recovery efficiency [%]*	66–87	71–87
Humidity recovery efficiency [%]	22–47	23–40
Heat exchanger type	cross-flow	cross-flow
Heat exchanger material	enthalpy	enthalpy
SEC class	E	E
ErP	2016	

*Heat recovery efficiency is specified in compliance with EN 13141-7.

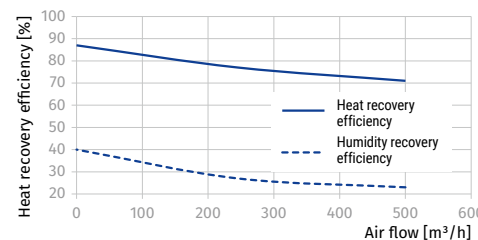
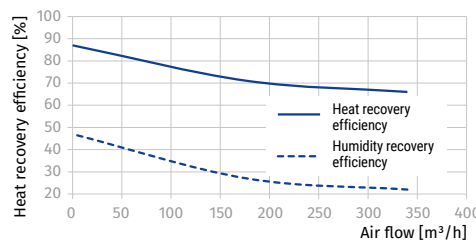
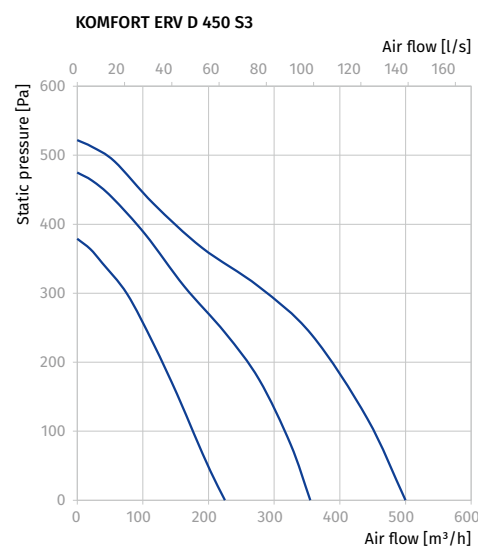
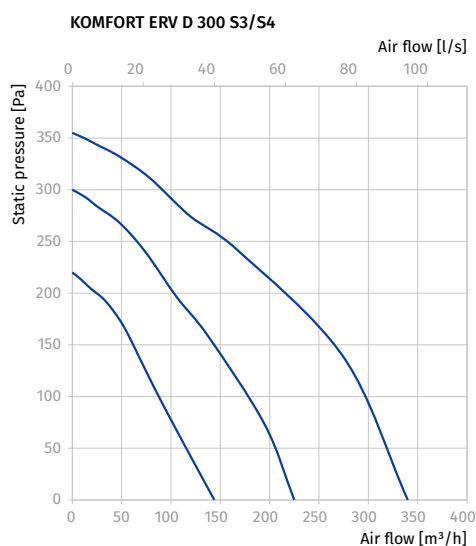

HEAT RECOVERY AIR HANDLING UNITS

Accessories

		KOMFORT ERV D 100 S3 KOMFORT ERV D 100 S4	KOMFORT ERV D 200 S3 KOMFORT ERV D 200 S4	KOMFORT ERV D 300 S3 KOMFORT ERV D 300 S4	KOMFORT ERV D 450 S3
G4 panel filter		FP 200x191x20 G4	FP 300x220x48 G4	FP 300x220x48 G4	FP 300x270x48 G4
F8 panel filter		FP 200x191x20 F8	FP 300x220x48 F8	FP 300x220x48 F8	FP 300x270x48 F8
Summer block		SB C4 300/220	SB C4 300/220	SB C4 300/270	SB C4 300/270

KOMFORT EC DBE

Suspended heat recovery air handling units

Features

- Air handling units for efficient supply and exhaust ventilation in flats, houses, cottages and other buildings.
- For controllable mechanical energy saving ventilation systems.
- Heat recovery minimises ventilation heat losses.
- Control of air exchange for creating comfortable indoor microclimate.
- Compatible with round Ø 160, 200, 250, 315, 400 mm air ducts.



Air flow:
up to 4300 m³/h
1195 l/s



Heat recovery efficiency:
up to 90 %



Design

- The casing is made of double-skinned aluzinc panels, internally filled with 20 mm mineral wool layer for heat and sound insulation.
- The casing has fixing brackets with vibration absorbing connectors for easy installation.
- The spigots for connection to the air ducts are located at the side of the unit and are rubber sealed for airtight connection to the air ducts.
- The service panel ensures easy access to the internals for cleaning, filter replacement and other maintenance operations.

KOMFORT EC DBE... 300/550/900

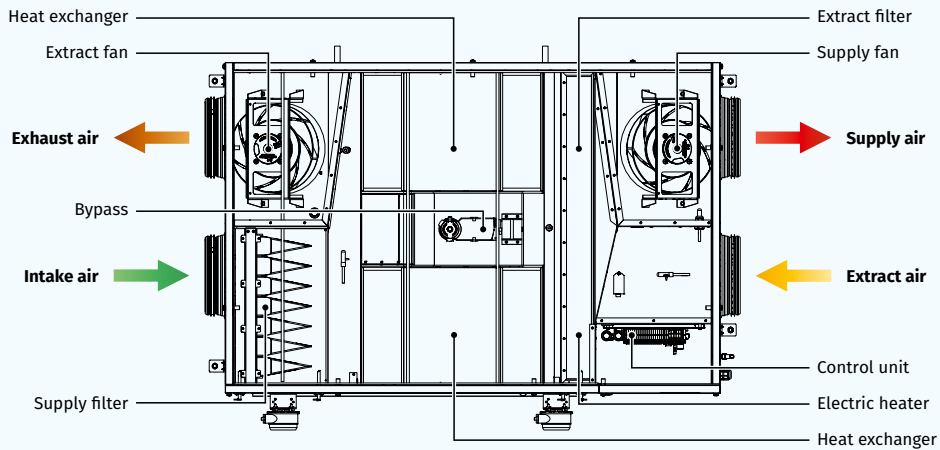

KOMFORT EC DBE... 2000/3000

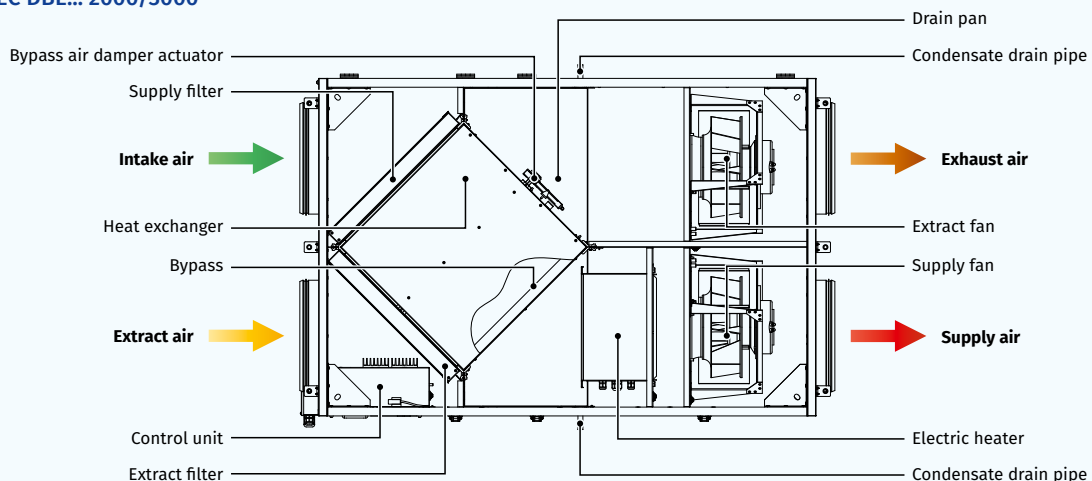

Fans

- High-efficient external rotor EC motors and centrifugal impellers with backward curved blades are used for air supply and exhaust.
- EC motors have the best power consumption to air flow ratio and meet the latest demands concerning energy saving and high-efficient ventilation.
- EC motors are featured with high performance, low noise level and totally controllable speed range.
- Dynamically balanced impellers.

Heat recovery

- The **KOMFORT EC DBE 300/550/900** unit is equipped with a plate counter-flow polystyrene heat exchanger for heat recovery. The drain pan located under the heat exchanger is designed for condensate collection and drainage.
- The **KOMFORT EC DBE 2000/3000** unit is equipped with a plate cross-flow aluminum heat exchanger for heat recovery. The drain pan located under the heat exchanger is designed for condensate collection and drainage.
- The **KOMFORT EC DBE...-E 300/550/900** unit is equipped with an enthalpy plate counter-flow heat exchanger for energy (heat and humidity) recovery. Due to humidity recovery condensate is not generated in the enthalpy heat exchanger.

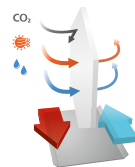

- The air flows are completely separated in the heat exchanger. Thus smells and contaminants are not transferred from the extract air to the supply air.
- Heat recovery is based on heat and/or humidity transfer through the heat exchanger plates. In the cold season supply air is heated in the heat exchanger by transferring the heat energy of warm and humid extract air to the cold fresh air. Heat recovery minimizes ventilation heat losses and heating costs respectively.
- In the warm season the heat exchanger performs reverse and intake air is cooled in the heat exchanger by the cool extract air. That reduces operation load on air conditioners and saves electricity.

Air heater

- The unit is equipped with an electric heater for operation during cold seasons at low outside temperature.
- The integrated electric heater is activated to warm up supply air flow if set indoor air temperature may not be reached by means of heat recovery only.
- Smooth heat output control ensures automatic supply air temperature maintaining.
- Two integrated overheat protection thermostats, one actuated at +60 °C with automatic restart and the other one actuated at +90 °C with manual restart.

Bypass

- The units are equipped with a bypass for summer ventilation (room cooling by cool air from outside) and heat exchanger freeze protection.

Air filtration

- The built-in G4 supply filter and G4 extract filter provide air filtration.
- The F7 supply filter (specially ordered accessory) may be used for efficient supply air filtration.

Mounting

- Ceiling mounting with fixing brackets.
- The correct mounted unit must provide free condensate collection and drainage as well as good access for servicing and filter replacement.
- Access for servicing and cleaning the filter: from the right or left side panel, depending on the unit modification.

Control and automation

- The units are equipped with an S21 integrated automation system. The remote control panel is not included in the delivery set (available separately).
- The S21 controller allows integrating the unit into the **Smart Home** system or **BMS (Building Management System)**.
- The unit can be controlled by the **Blauberg AHU** mobile application via Wi-Fi.





Download the **Blauberg AHU** app for Android

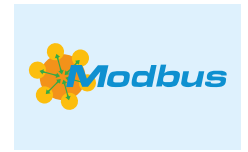

Download the **Blauberg AHU** app for iOS



Automation functions

Functions	Description
Unit control via Wi-Fi using a mobile application	+
Unit control via a wired remote control panel	S22 control panel (option) 
Unit control via a wireless remote control panel	S22 Wi-Fi control panel (option) 
Unit control via a wired remote LCD control panel	S25 control panel (option) 
BMS (Building Management System)	RS-485 Wi-Fi Ethernet MODBUS (RTU, TCP)
Blauberg Cloud Server service	+
Speed selection	+
Filter replacement indication	by filter timer by filter clogging differential pressure switch (only units with DTV)
Alarm indication	full alarm description in the mobile application
Week-scheduled operation	+
Bypass	automatic manual
Timer	+
Boost mode	+
Fireplace mode	+
Freeze protection	through cyclic stops of the supply fan through preheating (option)
Cooler connection	option
Minimum supply air temperature control	+
Humidity control	option
CO ₂ control	option
VOC control	option
PM2.5 control	option
Fire alarm sensor connection	option

Option: function is available when purchasing the appropriate accessory (see the "Accessories" section).

Designation key

Series	Motor type	Mounting type	Bypass	Heater type	Rated air flow [m³/h]	Heat exchanger type	Service side	Control	Additional elements
KOMFORT	EC: electronically commutated motor	D: suspended mounting, horizontally directed spigots	B: with a bypass	E: electric heater	300; 550; 900; 2000; 3000	- : heat recovery E: energy recovery	L: left R: right	S21	-: no additional elements DTV: equipped with a differential pressure switch to control filter contamination

Overall dimensions [mm]

Model	Ø D	B	B1	H	L	L1
KOMFORT EC DBE 300(-E) S21	160	485	577	290	1238	1291
KOMFORT EC DBE 550(-E) S21	200	827	960	280	1238	1291
KOMFORT EC DBE 900(-E) S21	250	1351	1485	318	1349	1402
KOMFORT EC DBE 2000 S21	315	950	-	762	1400	1452
KOMFORT EC DBE 3000 S21	400	1265	-	854	1835	1888

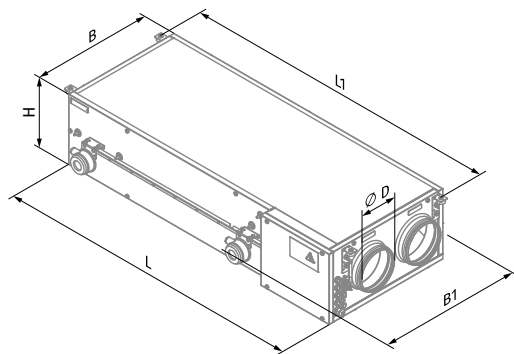

KOMFORT EC DBE 300

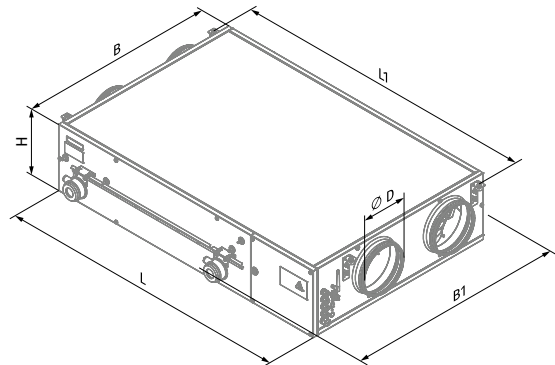

KOMFORT EC DBE 550

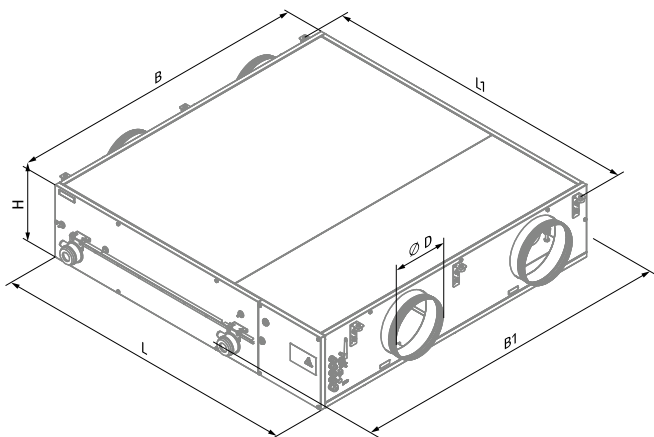

KOMFORT EC DBE 900

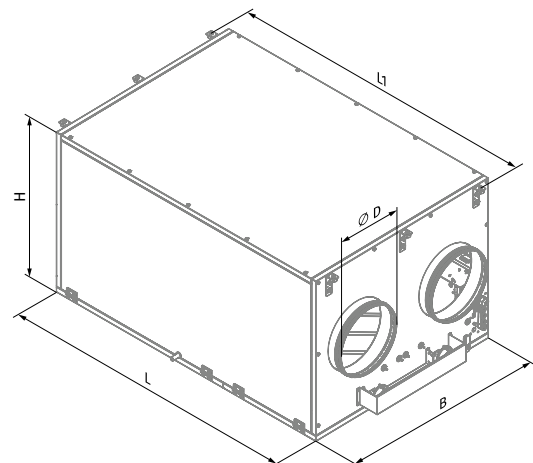

KOMFORT EC DBE 2000 / KOMFORT EC DBE 3000

HEAT RECOVERY AIR HANDLING UNITS

Technical data

Parameters	KOMFORT EC DBE 300 S21	KOMFORT EC DBE 300-E S21	KOMFORT EC DBE 550 S21	KOMFORT EC DBE 550-E S21	KOMFORT EC DBE 900 S21	KOMFORT EC DBE 900-E S21	KOMFORT EC DBE 2000 S21	KOMFORT EC DBE 3000 S21
Voltage [V / 50 (60) Hz]	1~230	1~230	1~230	1~230	1~230	1~230	3~400	3~400
Max. unit power without electric heater [W]	180	180	297	297	442	442	876	2226
Max. unit current without electric heater [A]	1.4	1.4	2.4	2.4	3.1	3.1	5.3	3.5
Electric heater power [W]	1500	1500	2000	2000	3300	3300	15000	21000
Electric heater current [A]	6.5	6.5	8.7	8.7	14.3	14.3	21.7	30.0
Max. power with electric heater [W]	1680	1680	2297	2297	3742	3742	15876	23226
Max. current with electric heater [A]	7.9	7.9	11.1	11.1	17.4	17.4	27.0	33.5
Maximum air flow [m³/h (l/s)]	340 (94)	340 (94)	620 (172)	620 (172)	1030 (286)	1030 (286)	2100 (583)	4300 (1195)
RPM [min⁻¹]	3270	3270	3100	3100	2720	2720	2920	3400
Sound pressure level at 3 m [dBA]	27	27	30	30	33	33	36	46
Transported air temperature [°C]	-25...+40	-25...+40	-25...+40	-25...+40	-25...+40	-25...+40	-25...+40	-25...+40
Casing material	aluzinc	aluzinc	aluzinc	aluzinc	aluzinc	aluzinc	aluzinc	aluzinc
Insulation	20 mm, mineral wool	20 mm, mineral wool	20 mm, mineral wool	20 mm, mineral wool	20 mm, mineral wool	20 mm, mineral wool	25 mm, mineral wool	25 mm, mineral wool
Extract filter	G4	G4	G4	G4	G4	G4	G4	G4
Supply filter	G4 (F7 option)	G4 (F7 option)	G4 (F7 option)	G4 (F7 option)	G4 (F7 option)	G4 (F7 option)	G4	G4
Connected air duct diameter [mm]	160	160	200	200	250	250	315	400
Weight [kg]	44	44	67	67	111	111	140	281
Heat recovery efficiency [%]	72-90	69-87	78-90	69-87	75-88	69-85	50-67	59-72
Heat exchanger type	counter-flow	counter-flow	counter-flow	counter-flow	counter-flow	counter-flow	cross-flow	cross-flow
Heat exchanger material	polystyrene	enthalpy	polystyrene	enthalpy	polystyrene	enthalpy	aluminum	aluminum
SEC class	A	A	A	A	A	A	NRVU	NRVU

KOMFORT EC DBE 300

Sound power level, A-weighted	Total	Octave frequency band [Hz]								LpA 3 m	LpA 1 m
		63	125	250	500	1000	2000	4000	8000		
L _{WA} to supply inlet [dBA]	66	13	51	65	54	51	47	37	28		
L _{WA} to supply outlet [dBA]	75	14	53	68	65	67	69	64	64		
L _{WA} to exhaust inlet [dBA]	62	11	45	61	52	51	48	38	34		
L _{WA} to exhaust outlet [dBA]	71	12	47	62	66	61	64	55	61		
L _{WA} to environment [dBA]	48	17	30	43	45	36	35	31	35	27	37

Point	Unit power [W]
1	174
2	168
3	152
4	77
5	74
6	68
7	19
8	19
9	18

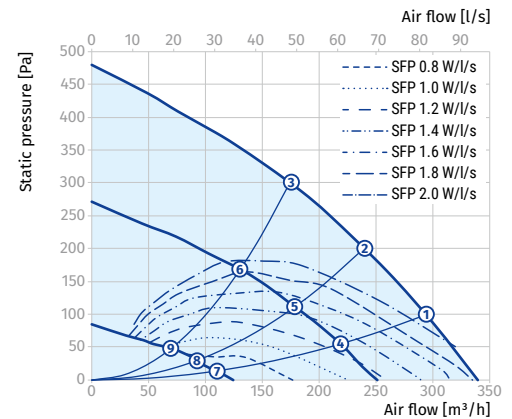

KOMFORT EC DBE 300 S21

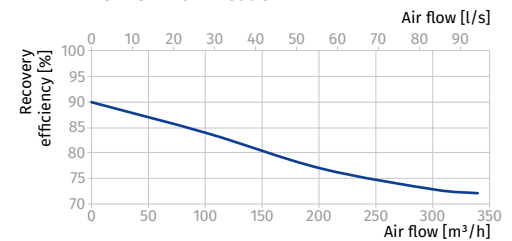

KOMFORT EC DBE 300-E S21

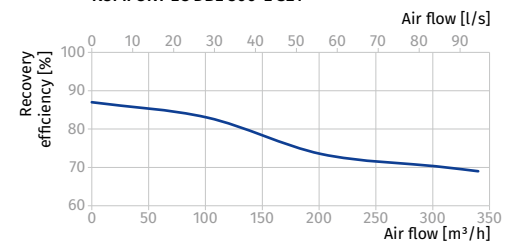

KOMFORT EC DBE 550

Sound power level, A-weighted	Total	Octave frequency band [Hz]								LpA 3 m	LpA 1 m
		63	125	250	500	1000	2000	4000	8000		
LWA to supply inlet [dBA]	69	26	60	68	54	53	48	40	29		
LWA to supply outlet [dBA]	76	27	62	71	66	68	68	66	64		
LWA to exhaust inlet [dBA]	69	26	60	68	54	53	48	40	29		
LWA to exhaust outlet [dBA]	66	24	55	65	53	53	49	41	35		
LWA to environment [dBA]	50	29	40	46	46	38	36	34	36	30	40

Data provided for point 1 of the air flow diagram

Point	Unit power [W]
1	294
2	285
3	271
4	109
5	106
6	101
7	34
8	34
9	32

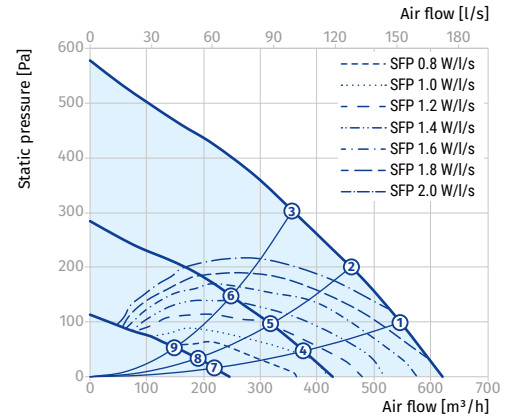

KOMFORT EC DBE 550 S21

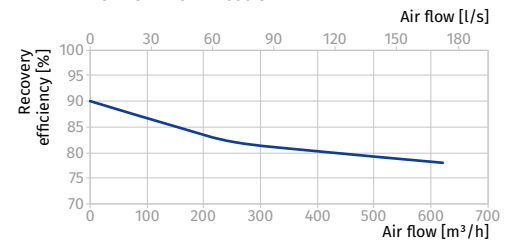

KOMFORT EC DBE 550-E S21

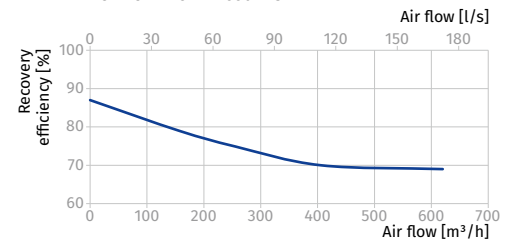

KOMFORT EC DBE 900

Sound power level, A-weighted	Total	Octave frequency band [Hz]								LpA 3 m	LpA 1 m
		63	125	250	500	1000	2000	4000	8000		
LWA to supply inlet [dBA]	80	30	64	72	69	74	73	71	71		
LWA to supply outlet [dBA]	70	29	62	69	58	59	53	45	36		
LWA to exhaust inlet [dBA]	78	29	60	69	72	70	71	64	70		
LWA to exhaust outlet [dBA]	69	28	58	68	59	61	56	48	44		
LWA to environment [dBA]	53	33	42	47	49	44	41	39	43	33	43

Point	Unit power [W]
1	442
2	442
3	442
4	160
5	149
6	147
7	46
8	43
9	40

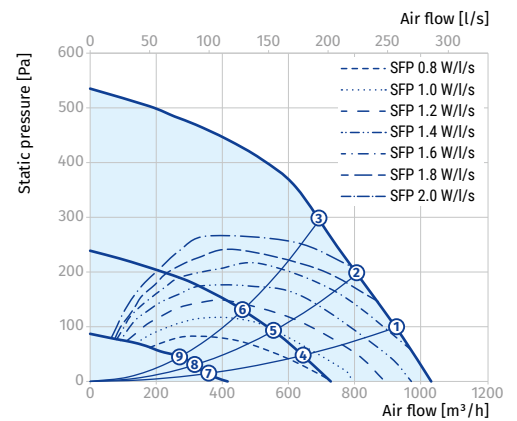

KOMFORT EC DBE 900 S21

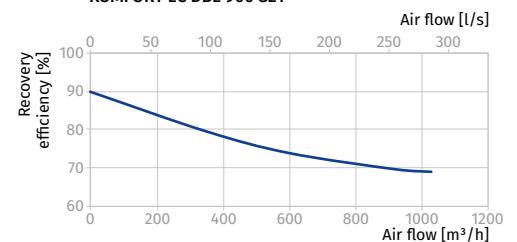

KOMFORT EC DBE 900-E S21

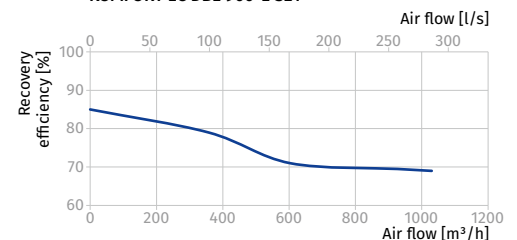

HEAT RECOVERY AIR HANDLING UNITS

KOMFORT EC DBE 2000

Sound power level, A-weighted	Total	Octave frequency band [Hz]								LpA 3 m	LpA 1 m
		63	125	250	500	1000	2000	4000	8000		
L _{WA} to supply inlet [dBA]	75	37	68	74	61	58	51	43	31		
L _{WA} to supply outlet [dBA]	82	38	70	77	73	75	73	70	68		
L _{WA} to exhaust inlet [dBA]	72	33	61	71	60	58	53	45	40		
L _{WA} to exhaust outlet [dBA]	78	34	63	72	74	68	69	62	67		
L _{WA} to environment [dBA]	56	40	47	52	52	43	40	37	40	36	46

Point	Unit power [W]
1	875
2	866
3	836
4	320
5	318
6	301
7	84
8	84
9	74

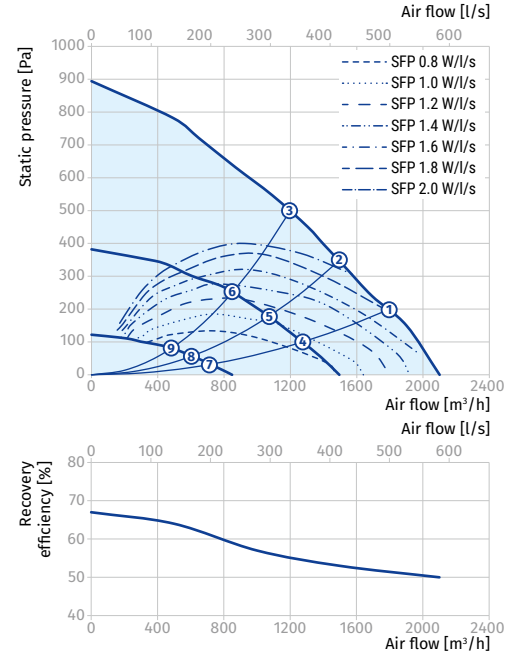







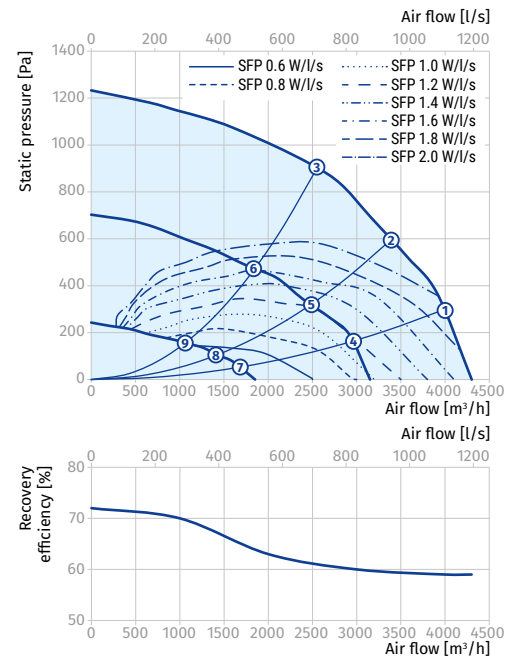













KOMFORT EC DBE 3000

Sound power level, A-weighted	Total	Octave frequency band [Hz]								LpA 3 m	LpA 1 m
		63	125	250	500	1000	2000	4000	8000		
L _{WA} to supply inlet [dBA]	90	48	83	89	72	69	60	50	37		
L _{WA} to supply outlet [dBA]	96	49	85	93	87	88	86	83	81		
L _{WA} to exhaust inlet [dBA]	86	44	75	85	71	69	62	53	47		
L _{WA} to exhaust outlet [dBA]	92	45	78	86	88	81	82	73	80		
L _{WA} to environment [dBA]	67	52	58	63	62	51	47	44	47	46	56

Point	Unit power [W]
1	2200
2	2220
3	2143
4	858
5	868
6	840
7	198
8	200
9	162



Accessories

		KOMFORT EC DBE 300 S21 KOMFORT EC DBE 300-E S21	KOMFORT EC DBE 550 S21 KOMFORT EC DBE 550-E S21	KOMFORT EC DBE 900 S21 KOMFORT EC DBE 900-E S21
G4 panel filter		FP 440x128x20 G4	FP 782x128x20 G4	FP 647x274x20 G4
G4 pocket filter		FPT 208x236x27 G4	FPT 392x236x27 G4	FPT 647x274x27 G4
F7 pocket filter		FPT 208x236x27 F7	FPT 392x236x27 F7	FPT 647x274x27 F7
Control panel		S22	S22	S22
Wireless control panel		S22 Wi-Fi	S22 Wi-Fi	S22 Wi-Fi
LCD control panel		S25	S25	S25
Humidity sensor		FS2	FS2	FS2
CO ₂ sensor with indication		CD-1	CD-1	CD-1
CO ₂ sensor		CD-2	CD-2	CD-2
Humidity sensor		HR-S	HR-S	HR-S
VOC sensor		DPWQ30600	DPWQ30600	DPWQ30600
CO ₂ sensor		DPWQ40200	DPWQ40200	DPWQ40200
Humidity sensor		DPWC11200	DPWC11200	DPWC11200
Kitchen hood		DAH 251-13	DAH 251-13	DAH 251-13
Electric preheater		EVH 160	EVH 200	EVH 250
Syphon kit (for the units without an enthalpy heat exchanger)		SFK 20x32	SFK 20x32	SFK 20x32
Silencer		SD 160	SD 200	SD 250
Backdraft air damper		VRV 160	VRV 200	VRV 250
Air damper		VKA 160	VKA 200	VKA 250
Electric actuator		LF230	LF230	LF230
Electric actuator		TF230	TF230	TF230

		KOMFORT EC DBE 2000 S21	KOMFORT EC DBE 3000 S21
G4 panel filter		FP 708x480x48 G4	FP 827x741x48 G4
Control panel		S22	S22
Wireless control panel		S22 Wi-Fi	S22 Wi-Fi
LCD control panel		S25	S25
Humidity sensor		FS2	FS2
CO ₂ sensor with indication		CD-1	CD-1
CO ₂ sensor		CD-2	CD-2
Humidity sensor		HR-S	HR-S
VOC sensor		DPWQ30600	DPWQ30600
CO ₂ sensor		DPWQ40200	DPWQ40200
Humidity sensor		DPWC11200	DPWC11200
Kitchen hood		DAH 251-13	DAH 251-13
Syphon kit (for the units without an enthalpy heat exchanger)		SFK 20x32	SFK 20x32
Silencer		SD 315	SD 400
Backdraft air damper		VRV 315	VRV 400
Air damper		VKA 315	VKA 400
Electric actuator		LF230	LF230
Electric actuator		TF230	TF230

KOMFORT EC DBW

Suspended heat recovery air handling units

Features

- Air handling units for efficient supply and exhaust ventilation in flats, houses, cottages and other buildings.
- Heat recovery minimises ventilation heat losses.
- Provide controllable air exchange to create the best suitable indoor microclimate.
- Compatible with round Ø 200, 250, 315, 400 mm round air ducts.



Air flow:
up to 4300 m³/h
1195 l/s



Heat recovery efficiency:
up to 90 %



Design

- The casing is made of double-skinned aluzinc panels, internally filled with 20 mm mineral wool layer for heat and sound insulation.
- The casing has fixing brackets with vibration absorbing connectors for easy installation.
- The spigots for connection to the air ducts are located at the side of the unit and are rubber sealed for airtight connection to the air ducts.
- The service panel ensures easy access to the internals for cleaning, filter replacement and other maintenance operations.

KOMFORT EC DBW... 300/550/900

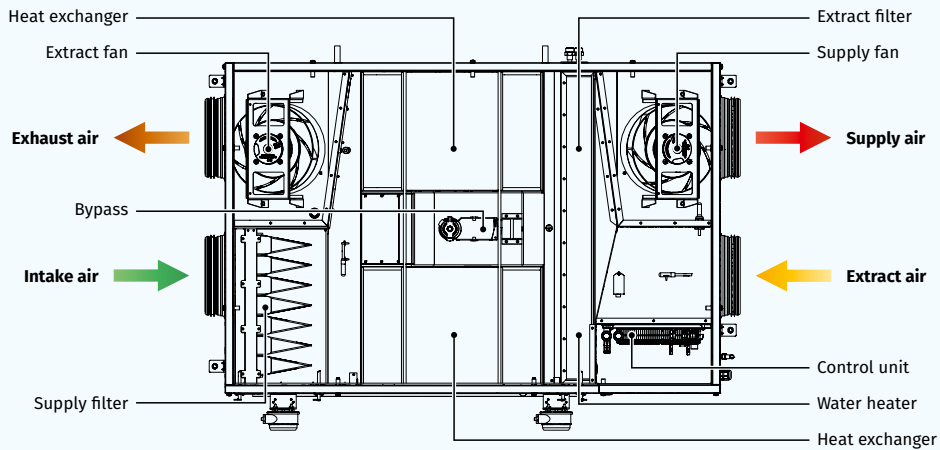

KOMFORT EC DBW... 2000/3000

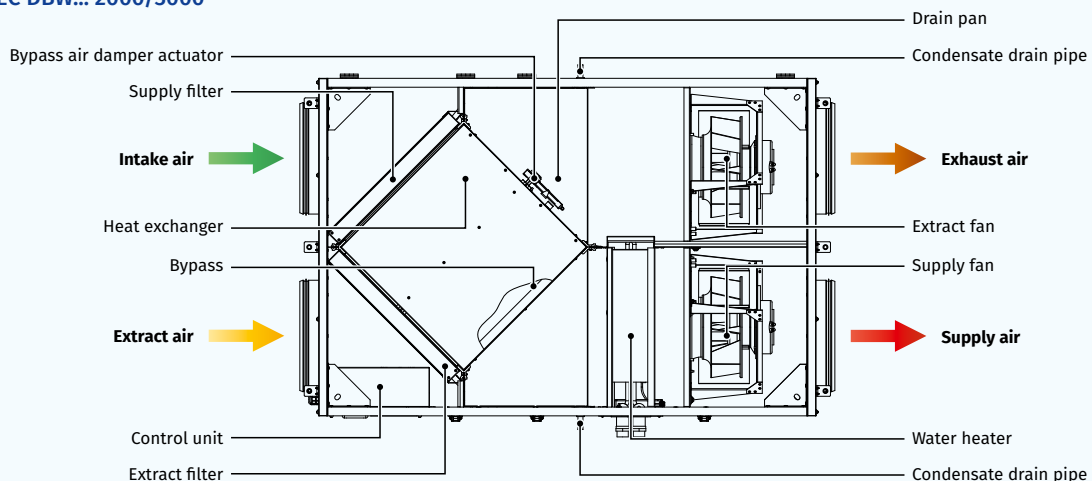

Fans

- High-efficient external rotor EC motors and centrifugal impellers with backward curved blades are used for air supply and exhaust.
- EC motors have the best power consumption to air flow ratio and meet the latest demands concerning energy saving and high-efficient ventilation.
- EC motors are featured with high performance, low noise level and totally controllable speed range.
- Dynamically balanced impellers.

Heat recovery

- The **KOMFORT EC DBW 550/900** unit is equipped with a plate counter-flow polystyrene heat exchanger for heat recovery. The drain pan located under the heat exchanger is designed for condensate collection and drainage.
- The **KOMFORT EC DBW 2000/3000** unit is equipped with a plate cross-flow aluminum heat exchanger for heat recovery. The drain pan located under the heat exchanger is designed for condensate collection and drainage.
- The **KOMFORT EC DBW...-E 550/900** unit is equipped with an enthalpy plate counter-flow heat exchanger for energy (heat and humidity) recovery. Due to humidity recovery condensate is not generated in the enthalpy heat exchanger.

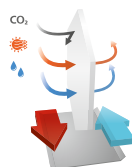

- The air flows are completely separated in the heat exchanger. Thus smells and contaminants are not transferred from the extract air to the supply air.
- Heat recovery is based on heat and/or humidity transfer through the heat exchanger plates. In the cold season supply air is heated in the heat exchanger by transferring the heat energy of warm and humid extract air to the cold fresh air. Heat recovery minimizes ventilation heat losses and heating costs respectively.
- In the warm season the heat exchanger performs reverse and intake air is cooled in the heat exchanger by the cool extract air. That reduces operation load on air conditioners and saves electricity.

Air heater

- The unit is equipped with a water (glycol) heater for operation at low outside air temperature.
- The integrated water heater is activated to warm up supply air flow if set indoor air temperature may not be reached by means of heat recovery only.
- Heat medium temperature control ensures supply air temperature maintaining.
- The air temperature sensor downstream of the waterheating coils and the return water temperature sensor are used for freezing protection of the water heater.

Bypass

- The units are equipped with a bypass for summer ventilation (room cooling by cool air from outside) and heat exchanger freeze protection.

Air filtration

- The built-in G4 supply filter and G4 extract filter provide air filtration.
- The F7 supply filter (specially ordered accessory) may be used for efficient supply air filtration.

Mounting

- Mounting to the ceiling with fixing brackets.
- The correct mounted unit must provide free condensate collection and drainage as well as good access for servicing and filter replacement.
- Access for servicing and cleaning the filter: from the right or left side panel, depending on the unit modification.

Control and automation

- The units are equipped with an S21 integrated automation system. The remote control panel is not included in the delivery set (available separately).
- The S21 controller allows integrating the unit into the **Smart Home** system or **BMS (Building Management System)**.
- The unit can be controlled by the **Blauberg AHU** mobile application via Wi-Fi.





Download the **Blauberg AHU** app for Android



Download the **Blauberg AHU** app for iOS



Automation functions

Functions	Description
Unit control via Wi-Fi using a mobile application	+
Unit control via a wired remote control panel	S22 control panel (option) 
Unit control via a wireless remote control panel	S22 Wi-Fi control panel (option) 
Unit control via a wired remote LCD control panel	S25 control panel (option) 
BMS (Building Management System)	RS-485 Wi-Fi Ethernet MODBUS (RTU, TCP)
Blauberg Cloud Server service	+
Speed selection	+
Filter replacement indication	by filter timer by filter clogging differential pressure switch (only units with DTV)
Alarm indication	full alarm description in the mobile application
Week-scheduled operation	+
Bypass	automatic manual
Timer	+
Boost mode	+
Fireplace mode	+
Freeze protection	through cyclic stops of the supply fan through preheating (option)
Cooler connection	option
Minimum supply air temperature control	+
Humidity control	option
CO ₂ control	option
VOC control	option
PM2.5 control	option
Fire alarm sensor connection	option

Option: function is available when purchasing the appropriate accessory (see the "Accessories" section).

Designation key

Series	Motor type	Mounting type	Bypass	Heater type	Rated air flow [m³/h]	Heat exchanger type	Service side	Control	Additional elements
KOMFORT	EC: electronically commutated motor	D: suspended mounting, horizontally directed spigots	B: with a bypass	W: water heater	550; 900; 2000; 3000	- _: heat recovery E: energy recovery	L: left R: right	S21	_: no additional elements DTV: equipped with a differential pressure switch to control filter contamination

Overall dimensions [mm]

Model	∅ D	B	B1	H	L	L1
KOMFORT EC DBW 550(-E) S21	199	827	960	283	1238	1286
KOMFORT EC DBW 900(-E) S21	249	1350	1485	317	1346	1395
KOMFORT EC DBW 2000 S21	315	950	-	761	1400	1453
KOMFORT EC DBW 3000 S21	400	1265	-	830	1835	1888

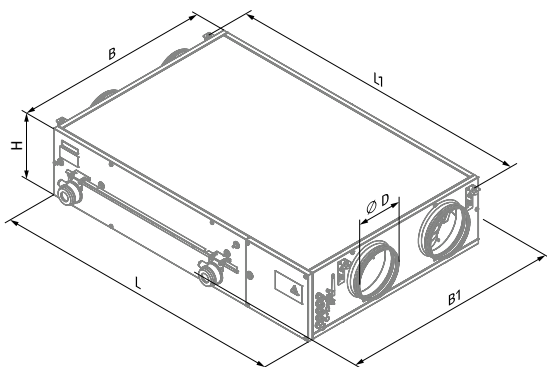

KOMFORT EC DBW 550

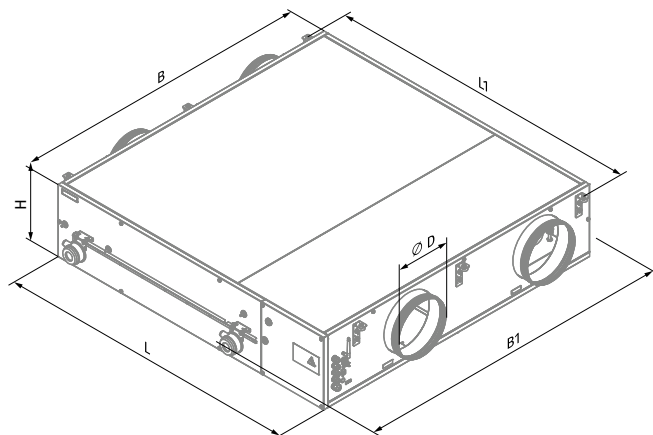

KOMFORT EC DBW 900

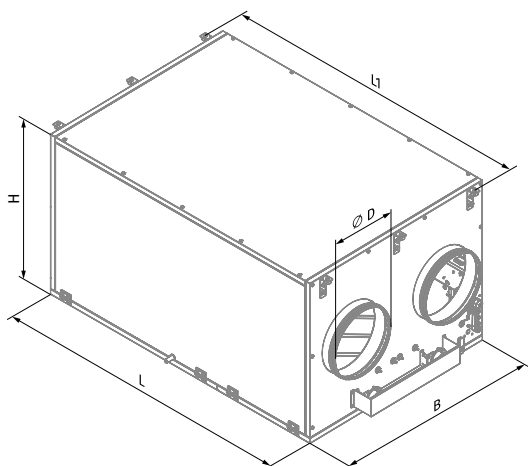

KOMFORT EC DBW 2000 / KOMFORT EC DBW 3000

Technical data

Parameters	KOMFORT EC DBW 550 S21	KOMFORT EC DBW 550-E S21	KOMFORT EC DBW 900 S21	KOMFORT EC DBW 900-E S21	KOMFORT EC DBW 2000 S21	KOMFORT EC DBW 3000 S21
Voltage [V / 50 (60) Hz]	1~230	1~230	1~230	1~230	3~400	3~400
Max. unit power [W]	297	297	442	442	876	2226
Max. unit current [A]	2.4	2.4	3	3	5.3	3.5
Number of water (glycol) coil rows	2	2	2	2	2	2
Maximum air flow [m³/h (l/s)]	620 (172)	620 (172)	1030 (286)	1030 (286)	2100 (583)	4300 (1195)
RPM [min⁻¹]	3100	3100	2720	2720	2920	3400
Sound pressure level at 3 m [dBA]	30	30	33	33	36	46
Transported air temperature [°C]	-25...+40	-25...+40	-25...+40	-25...+40	-25...+40	-25...+40
Casing material	aluzinc	aluzinc	aluzinc	aluzinc	aluzinc	aluzinc
Insulation	20 mm, mineral wool	20 mm, mineral wool	20 mm, mineral wool	20 mm, mineral wool	25 mm, mineral wool	25 mm, mineral wool
Extract filter	G4	G4	G4	G4	G4	G4
Supply filter	G4 (F7 option)	G4 (F7 option)	G4 (F7 option)	G4 (F7 option)	G4	G4
Connected air duct diameter [mm]	200	200	250	250	315	400
Weight [kg]	68	68	112	112	140	268
Heat recovery efficiency [%]	78-90	69-87	75-88	69-85	50-67	59-72
Heat exchanger type	counter-flow	counter-flow	counter-flow	counter-flow	cross-flow	cross-flow
Heat exchanger material	polystyrene	enthalpy	polystyrene	enthalpy	aluminum	aluminum
SEC class	A	A	A	A	NRVU	NRVU

KOMFORT EC DBW 550

Sound power level, A-weighted	Total	Octave frequency band [Hz]								LpA 3 m	LpA 1 m
		63	125	250	500	1000	2000	4000	8000		
L _{WA} to supply inlet [dBA]	69	26	60	68	54	53	48	40	29		
L _{WA} to supply outlet [dBA]	76	27	62	71	66	68	68	66	64		
L _{WA} to exhaust inlet [dBA]	69	26	60	68	54	53	48	40	29		
L _{WA} to exhaust outlet [dBA]	66	24	55	65	53	53	49	41	35		
L _{WA} to environment [dBA]	50	29	40	46	46	38	36	34	36	30	40

Point	Unit power [W]
1	294
2	285
3	271
4	109
5	106
6	101
7	34
8	34
9	32

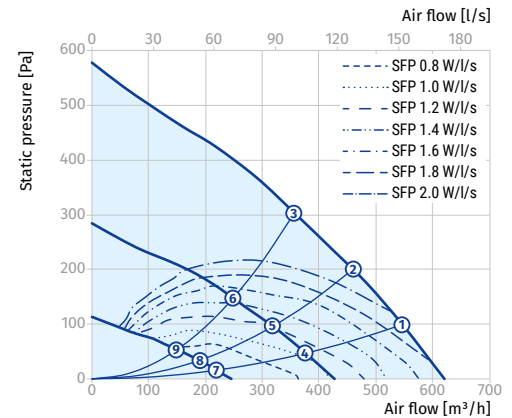

KOMFORT EC DBW 550 S21

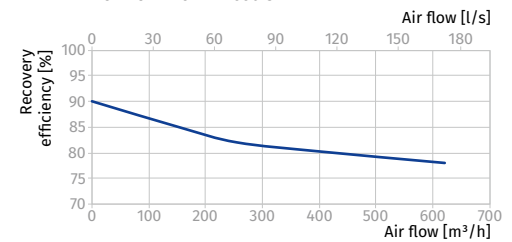

KOMFORT EC DBW 550-E S21

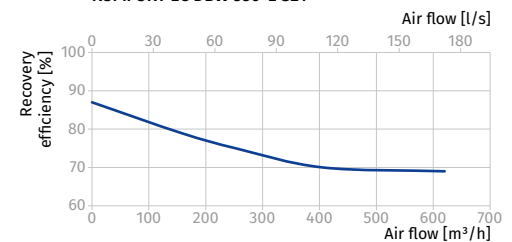

KOMFORT EC DBW 900

Sound power level, A-weighted	Total	Octave frequency band [Hz]								LpA 3 m	LpA 1 m
		63	125	250	500	1000	2000	4000	8000		
LWA to supply inlet [dBA]	80	30	64	72	69	74	73	71	71		
LWA to supply outlet [dBA]	70	29	62	69	58	59	53	45	36		
LWA to exhaust inlet [dBA]	78	29	60	69	72	70	71	64	70		
LWA to exhaust outlet [dBA]	69	28	58	68	59	61	56	48	44		
LWA to environment [dBA]	53	33	42	47	49	44	41	39	43	33	43

Point	Unit power [W]
1	442
2	442
3	442
4	160
5	149
6	147
7	46
8	43
9	40

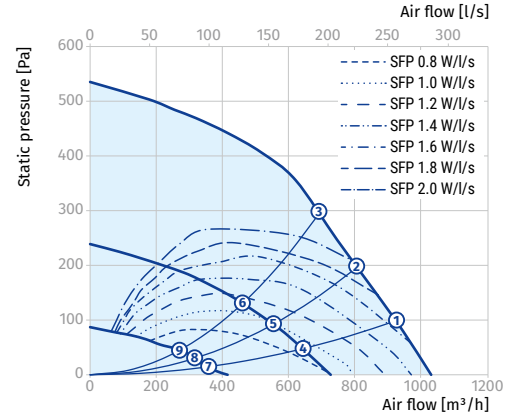

KOMFORT EC DBW 900 S21

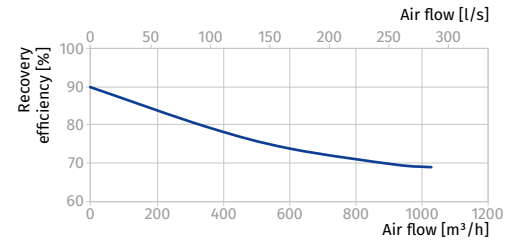

KOMFORT EC DBW 900-E S21

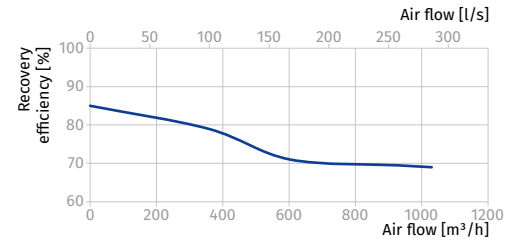

KOMFORT EC DBW 2000

Sound power level, A-weighted	Total	Octave frequency band [Hz]								LpA 3 m	LpA 1 m
		63	125	250	500	1000	2000	4000	8000		
LWA to supply inlet [dBA]	75	37	68	74	61	58	51	43	31		
LWA to supply outlet [dBA]	82	38	70	77	73	75	73	70	68		
LWA to exhaust inlet [dBA]	72	33	61	71	60	58	53	45	40		
LWA to exhaust outlet [dBA]	78	34	63	72	74	68	69	62	67		
LWA to environment [dBA]	56	40	47	52	52	43	40	37	40	36	46

Point	Unit power [W]
1	875
2	866
3	836
4	320
5	318
6	301
7	84
8	84
9	74

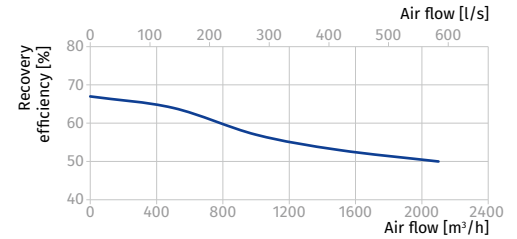
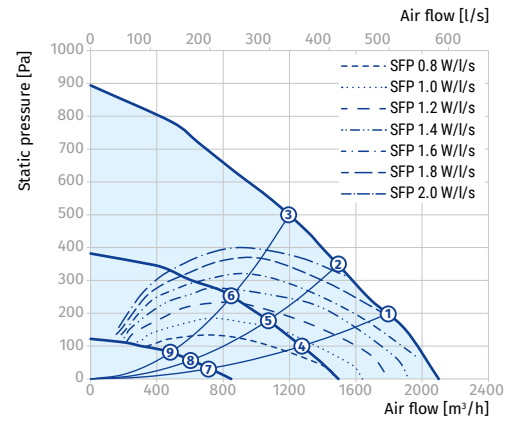

KOMFORT EC DBW 3000

Sound power level, A-weighted	Total	Octave frequency band [Hz]								LpA 3 m	LpA 1 m
		63	125	250	500	1000	2000	4000	8000		
L _{WA} to supply inlet [dBA]	90	48	83	89	72	69	60	50	37		
L _{WA} to supply outlet [dBA]	96	49	85	93	87	88	86	83	81		
L _{WA} to exhaust inlet [dBA]	86	44	75	85	71	69	62	53	47		
L _{WA} to exhaust outlet [dBA]	92	45	78	86	88	81	82	73	80		
L _{WA} to environment [dBA]	67	52	58	63	62	51	47	44	47	46	56

Point	Unit power [W]
1	2200
2	2220
3	2143
4	858
5	868
6	840
7	198
8	200
9	162

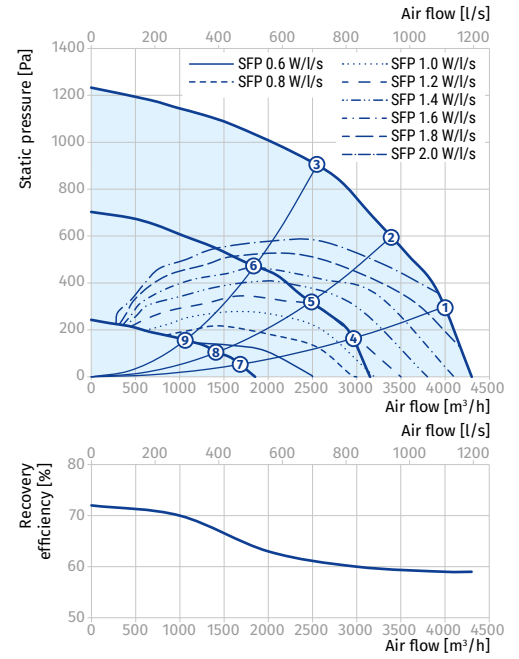

Hot water coil calculation diagram

KOMFORT EC DBW 550

Air temperature downstream of the water heating coils [°C]

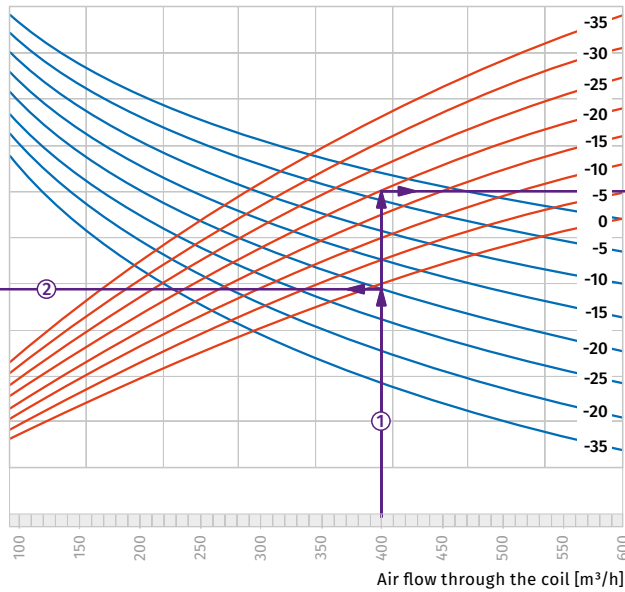
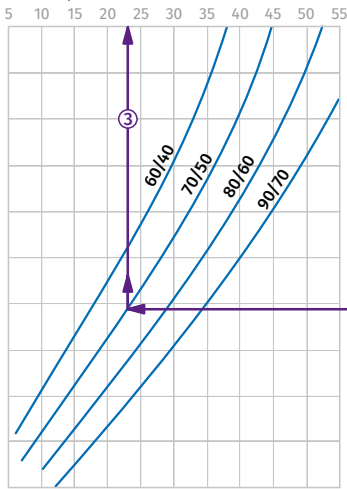

Coil heating capacity [kW]

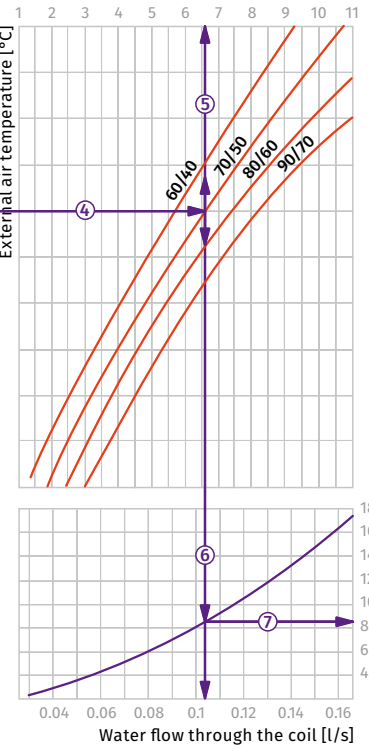

How to use water heater diagrams.

Sample parameters: Air flow = 400 m³/h.
Outside air temperature = -20 °C.
Water temperature (in/out) = +70/+50 °C.

- To calculate the maximum air temperature, find the intersection point of the air flow line (e.g., 400 m³/h) ① with the rated outer temperature shown in blue line (e.g., -20 °C) and draw the line ② to the left until it crosses the water in/out temperature curve (e.g., +70/+50). From this point draw a vertical line to the supply air temperature downstream of the heater (+23 °C) ③.

- To calculate the heater power, find the intersection point of the air flow ① with the rated winter temperature shown in red line (e.g., -20 °C) and draw the line ④ to the right until it crosses the water in/out temperature curve (e.g., +70/+50). From this point draw a vertical line to the heater power axis (6.6 kW) ⑤.
- To calculate the required water flow in the heater, prolong this line ⑤ downwards to the water flow axis (0.105 l/s).
- To calculate the water pressure drop in the heater, find the intersection point of the line ⑥ with the pressure loss curve and prolong the line ⑦ to the right on the water pressure drop axis (8.5 kPa).

KOMFORT EC DBW 900

Air temperature downstream of the water heating coils [°C]

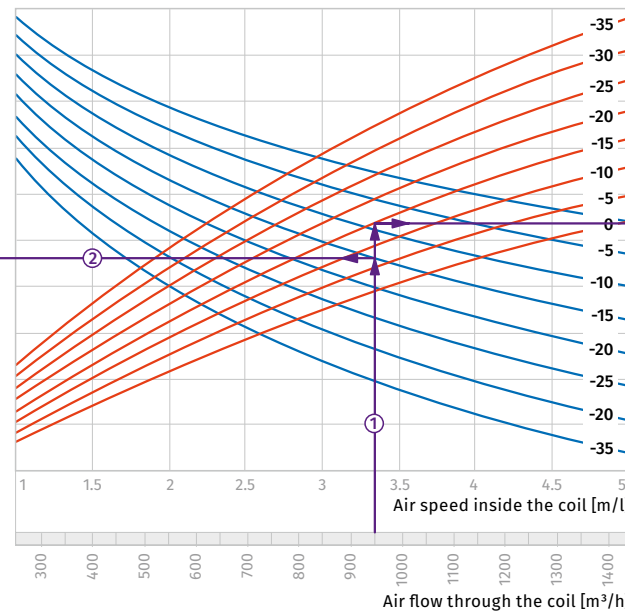
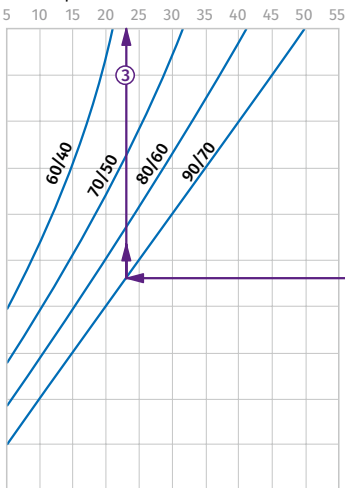

Coil heating capacity [kW]

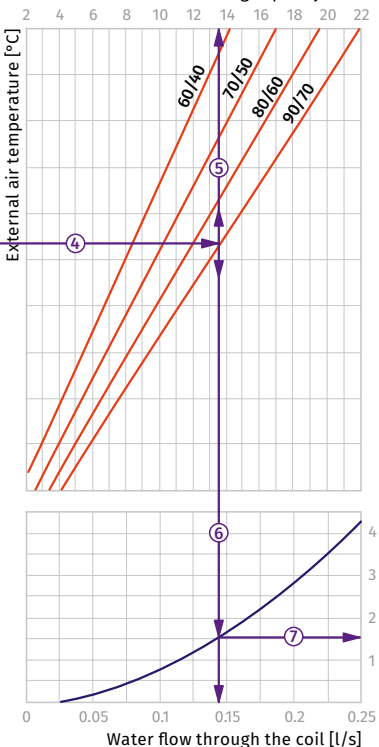

How to use water heater diagrams.

Sample parameters: Air flow = 950 m³/h.
Outside air temperature = -15 °C.
Water temperature (in/out) = +90/+70 °C.
The air flow is 950 m³/h and the air speed in the heater is 3.35 m/s ①.

- To calculate the maximum air temperature, find the intersection point of the air flow line ① with the rated outer temperature shown in blue line (e.g., -15 °C) and draw the line ② to the left until it crosses the water in/out temperature curve (e.g., +90/+70). From this point draw a vertical line to the supply air temperature downstream of the heater (+23 °C) ③.

- To calculate the heater power, find the intersection point of the air flow ① with the rated winter temperature shown in red line (e.g., -15 °C) and draw the line ④ to the right until it crosses the water in/out temperature curve (e.g., +90/+70). From this point draw a vertical line to the heater power axis (13.5 kW) ⑤.
- To calculate the required water flow in the heater, prolong this line ⑤ downwards to the water flow axis (0.14 l/s).
- To calculate the water pressure drop in the heater, find the intersection point of the line ⑥ with the pressure loss curve and prolong the line ⑦ to the right on the water pressure drop axis (1.5 kPa).

KOMFORT EC DBW 2000

Air temperature downstream of the water heating coils [°C]

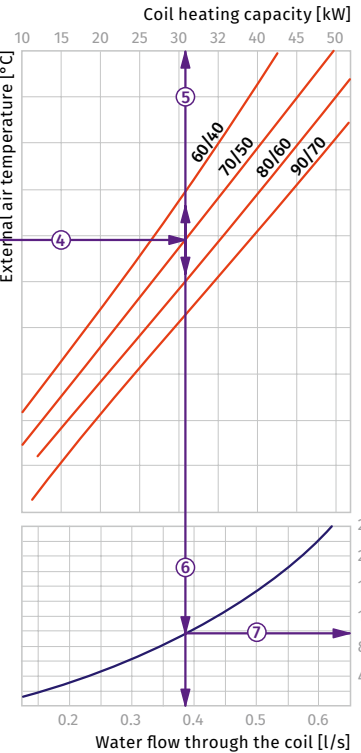
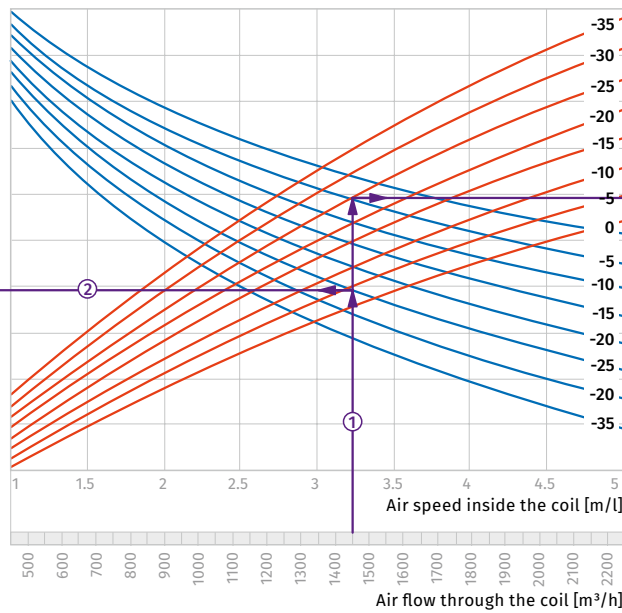
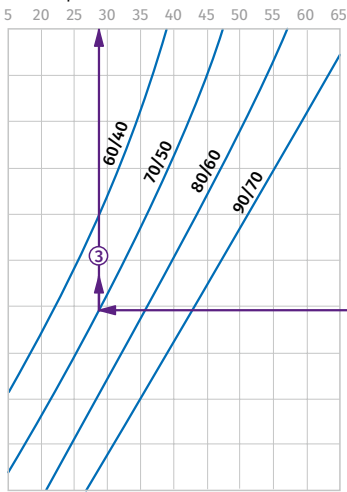

How to use water heater diagrams.

Sample parameters: Air flow = 1450 m³/h.
 Outside air temperature = -25 °C.
 Water temperature (in/out) = +70/+50 °C.
 The air flow is 1450 m³/h and the air speed in the heater is 3.2 m/s ①.

- To calculate the maximum air temperature find the intersection point of the air flow line ① with the rated outer temperature shown in blue line (e.g., -25 °C) and draw the line ② to the left until it crosses the water in/out temperature curve (e.g., +70/+50). From this point draw a vertical line to the supply air temperature downstream of the heater (+28 °C) ③.

- To calculate the heater power find the intersection point of the air flow ① with the rated winter temperature shown in red line (e.g., -25 °C) and draw the line ④ to the right until it crosses the water in/out temperature curve (e.g., +70/+50). From this point draw a vertical line to the heater power axis (31.0 kW) ⑤.
- To calculate the required water flow in the heater prolong this line ⑥ downwards to the water flow axis (0.38 l/s).
- To calculate the water pressure drop in the heater find the intersection point of the line ⑥ with the pressure loss curve and prolong the line ⑦ to the right on the water pressure drop axis (9.8 kPa).

KOMFORT EC DBW 3000

Air temperature downstream of the water heating coils [°C]

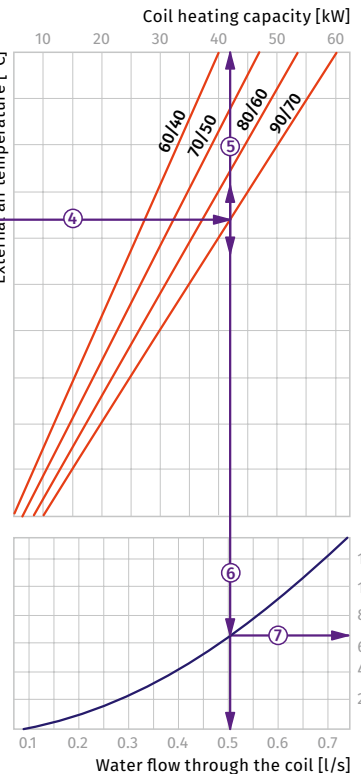
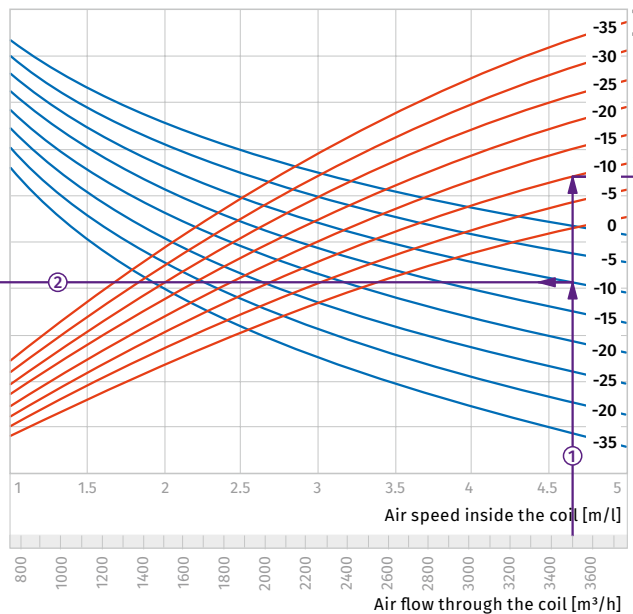
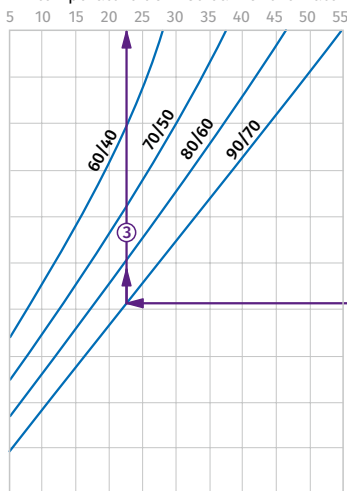

How to use water heater diagrams.























Sample parameters: Air flow = 3500 m³/h.
 Outside air temperature = -10 °C.
 Water temperature (in/out) = +90/+70 °C.
 The air flow is 3500 m³/h and the air speed in the heater is 4.65 m/s ①.



















- To calculate the maximum air temperature find the intersection point of the air flow line ① with the rated outer temperature shown in blue line (e.g., -10 °C) and draw the line ② to the left until it crosses the water in/out temperature curve (e.g., +90/+70). From this point draw a vertical line to the supply air temperature downstream of the heater (+22.5 °C) ③.

- To calculate the heater power find the intersection point of the air flow ① with the rated winter temperature shown in red line (e.g., -10 °C) and draw the line ④ to the right until it crosses the water in/out temperature curve (e.g., +90/+70). From this point draw a vertical line to the heater power axis (42.0 kW) ⑤.
- To calculate the required water flow in the heater prolong this line ⑥ downwards to the water flow axis (0.5 l/s).
- To calculate the water pressure drop in the heater find the intersection point of the line ⑥ with the pressure loss curve and prolong the line ⑦ to the right on the water pressure drop axis (6.5 kPa).

HEAT RECOVERY AIR HANDLING UNITS

Accessories

		KOMFORT EC DBW 550 S21 KOMFORT EC DBW 550-E S21	KOMFORT EC DBW 900 S21 KOMFORT EC DBW 900-E S21
G4 panel filter		FP 782x128x20 G4	FP 647x274x20 G4
G4 pocket filter		FPT 392x236x27 G4	FPT 647x274x27 G4
F7 pocket filter		FPT 392x236x27 F7	FPT 647x274x27 F7
Control panel		S22	S22
Wireless control panel		S22 Wi-Fi	S22 Wi-Fi
LCD control panel		S25	S25
Humidity sensor		FS2	FS2
CO ₂ sensor with indication		CD-1	CD-1
CO ₂ sensor		CD-2	CD-2
Humidity sensor		HR-S	HR-S
VOC sensor		DPWQ30600	DPWQ30600
CO ₂ sensor		DPWQ40200	DPWQ40200
Humidity sensor		DPWC11200	DPWC11200
Kitchen hood		DAH 251-13	DAH 251-13
Electric preheater		EVH 200	EVH 250
Syphon kit (for the units without an enthalpy heat exchanger)		SFK 20x32	SFK 20x32
Silencer		SD 200	SD 250
Backdraft air damper		VRV 200	VRV 250
Air damper		VKA 200	VKA 250
Electric actuator		LF230	LF230
Electric actuator		TF230	TF230
Water mixing unit		WMG	WMG

		KOMFORT EC DBW 2000 S21	KOMFORT EC DBW 3000 S21
G4 panel filter		FP 708x480x48 G4	FP 827x741x48 G4
Control panel		S22	S22
Wireless control panel		S22 Wi-Fi	S22 Wi-Fi
LCD control panel		S25	S25
Humidity sensor		FS2	FS2
CO ₂ sensor with indication		CD-1	CD-1
CO ₂ sensor		CD-2	CD-2
Humidity sensor		HR-S	HR-S
VOC sensor		DPWQ30600	DPWQ30600
CO ₂ sensor		DPWQ40200	DPWQ40200
Humidity sensor		DPWC11200	DPWC11200
Kitchen hood		DAH 251-13	DAH 251-13
Syphon kit (for the units without an enthalpy heat exchanger)		SFK 20x32	SFK 20x32
Silencer		SD 315	-
Backdraft air damper		VRV 315	VRV 400
Air damper		VKA 315	VKA 400
Electric actuator		LF230	LF230
Electric actuator		TF230	TF230
Water mixing unit		WMG	WMG

KOMFORT EC LB(E)

Heat recovery air handling units

Features

- Air handling units for efficient supply and exhaust ventilation in flats, houses, cottages and other buildings.
- Used to create controlled energy-saving ventilation systems.
- The heat recovery technology is used to minimize ventilation heat losses.
- Control of air exchange for creating comfortable indoor microclimate.
- Compatible with round Ø 160, 200 or 250 mm air ducts.



Air flow:
up to 830 m³/h
231 l/s



Heat recovery efficiency:
up to 98 %



Design

- The casing is made of double-skinned aluzinc panels, internally filled with mineral wool layer 40 mm for heat- and sound-insulation.
- The casing has mounting brackets with anti-vibration rubber mounts for easy installation.
- The unit is equipped with service hatches on the side panels for easy maintenance of filters. This design enables the left-hand and right-hand installation of the unit.
- The spigots are located at the sides of the unit and are equipped with rubber seals for airtight connection to the air ducts.

Fans

- High-efficient external rotor EC motors and centrifugal impellers are used for air supply and exhaust.
- The forward curved blades in **KOMFORT EC LB(E) 300/LB(E) 400** provide permanent air flow.
- The **KOMFORT EC LB(E) 700** model has impellers with backward curved blades.
- EC motors have the best power consumption to air capacity ratio and meet the latest demands concerning energy saving and high-efficient ventilation.
- EC motors are featured with high performance, low noise level and totally controllable speed range.
- The impellers are dynamically balanced.

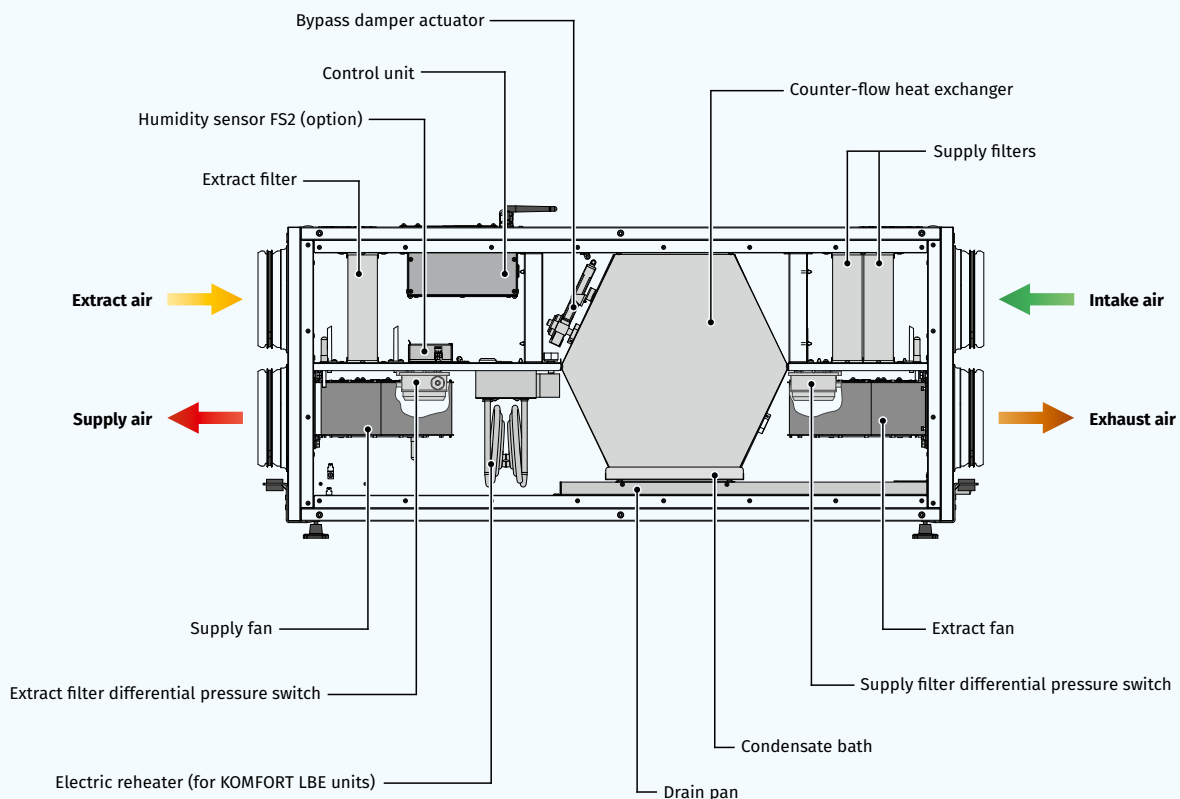

Heat recovery

- o The **KOMFORT EC LB(E)...** unit is equipped with a plate counter-flow polystyrene heat exchanger for heat recovery. The unit condensate is collected and drained to the drain pan under the heat exchanger.



- o The **KOMFORT EC LB(E)....-E** unit is equipped with an enthalpy plate counter-flow heat exchanger for energy (heat and humidity) recovery. Due to humidity recovery condensate is not generated in the enthalpy heat exchanger.



- o The air flows are completely separated in the heat exchanger. Thus smells and contaminants are not transferred from the extract air to the supply air.
- o Heat recovery is based on heat and/or humidity transfer through the heat exchanger plates. In the cold season supply air is heated in the heat exchanger by transferring the heat energy of warm and humid extract air to the cold fresh air. Heat recovery minimizes ventilation heat losses and heating costs respectively.
- o In the warm season the heat exchanger performs reverse and intake air is cooled in the heat exchanger by the cool extract air. That reduces operation load on air conditioners and saves electricity.

Air filtration

- o Two built-in G4 and F7 filters provide efficient supply air filtration.
- o The G4 filter is used for extract air filtration.

Air heater

- o The **KOMFORT EC LBE S21** units are equipped with an electric heater for additional heating of supply air downstream of the heat exchanger.
- o The **KOMFORT EC LB S21** units are not equipped with built-in heaters but both a preheater and a reheater can be purchased separately.

Bypass

- o The **KOMFORT EC LB(E) S21** model is equipped with a bypass which is automatically opened in summer if there is a need to cool down the ventilated area with cool intake air.
- o The **KOMFORT EC LB S14** unit is equipped with a bypass that is opened manually.
- o If the unit is equipped with an electric heater, the bypass is used for freeze protection of the heat exchanger.

Mounting

- o Mounting on floor or ceiling with fixing brackets.
- o The correct mounted unit must provide condensate collecting and drainage as well as access to service mounting and filter replacement.

Control and automation

- o **KOMFORT EC LB... S21** units are equipped with an integrated automation system. The remote control panel is not included in the delivery set (purchased separately).
- o The S21 controller allows integrating the unit into the **Smart Home** system or **BMS (Building Management System)**.
- o The unit can be controlled via the **Blauberg AHU** mobile application via Wi-Fi.



Download the **Blauberg AHU** app for Android





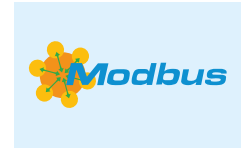

Download the **Blauberg AHU** app for iOS



- o The **KOMFORT EC LB S14** units have an integrated control system with a wall-mounted control panel S14 with a LED indication.

Automation functions

Functions	KOMFORT EC LB(E) S21	KOMFORT EC LB S14
Unit control via Wi-Fi using a mobile application	+	-
Unit control via a wired remote control panel	S22 control panel (option) 	S14 control panel 
Unit control via a wireless remote control panel	S22 Wi-Fi control panel (option) 	-
Unit control via a remote wired LCD control panel	S25 control panel (option) 	-
BMS (Building Management System)	RS-485	-
	Wi-Fi	-
	Ethernet	-
	MODBUS (RTU, TCP)	-
Blauberg Cloud Server service	+	-
Speed selection	+	+
Filter replacement indication	by hour meter readings	by hour meter readings
	by filter clogging differential pressure switch	-
Alarm indication	full alarm description in the mobile application	LED alarm indication
Week-scheduled operation	+	-
Bypass	automatic	-
	manual	manual
Timer	+	-
Boost mode	+	-
Fireplace mode	+	-
Freeze protection	through cyclic stops of the supply fan	through cyclic stops of the supply fan
	through preheating (option)	-
	using a bypass	-
Reheater connection	option	-
Cooler connection	option	-
Minimum supply air temperature control	+	-
Humidity control	option	option
CO ₂ control	option	option
VOC control	option	-
PM2.5 control	option	-
Fire alarm sensor connection	option	option

Option: function is available when purchasing the appropriate accessory (see the "Accessories" section).

Designation key

Series	Motor type	Spigot modification	Bypass	Heater type	Rated air flow, [m ³ /h]	Heat exchanger type	Control
KOMFORT	EC: electronically commutated motor	L: horizontal spigot orientation	B: with a bypass	_ : without a heater E: electric heater	300; 400; 700	_ : heat recovery -E: energy recovery	S21 S14

Overall dimensions [mm]

Model	∅ D	B	B1	H	L	L1
KOMFORT EC LB 300(-E) S21/S14	157	566	480	479	1083	1180
KOMFORT EC LBE 300(-E) S21/S14	157	566	480	479	1083	1180
KOMFORT EC LB 400(-E) S21/S14	197	682	596	504	1094	1191
KOMFORT EC LBE 400(-E) S21/S14	197	682	596	504	1094	1191
KOMFORT EC LB 700(-E) S21/S14	247	866	700	601	1282	1379
KOMFORT EC LBE 700(-E) S21/S14	247	866	700	601	1282	1379

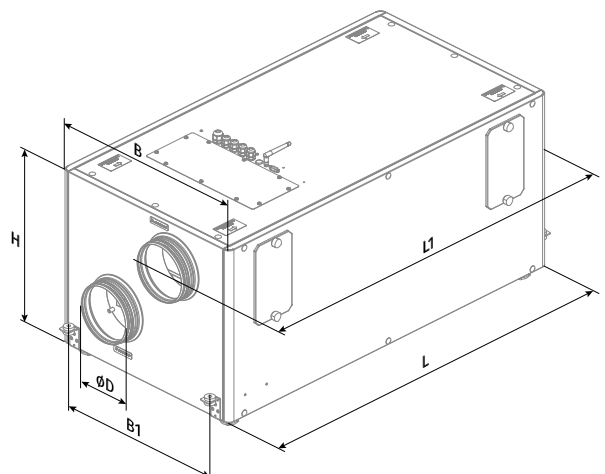

Technical data

Parameters	KOMFORT EC LB 300 S21 KOMFORT EC LB 300 S14	KOMFORT EC LBE 300 S21	KOMFORT EC LB 300-E S21 KOMFORT EC LB 300-E S14	KOMFORT EC LBE 300-E S21
Voltage [V / 50 (60) Hz]	1~ 230	1~ 230	1~ 230	1~ 230
Power (without a heater) [W]	182	182	182	182
Current (without a heater) [A]	1.4	1.4	1.4	1.4
Electric heater power [W]	-	2800	-	2800
Electric heater current [A]	-	12.2	-	12.2
Power (with a heater) [W]	182	2982	182	2982
Current (with a heater) [A]	1.4	13.6	1.4	13.6
Maximum air flow [m³/h (l/s)]	380 (106)	380 (106)	380 (106)	380 (106)
RPM [min⁻¹]	2100	2100	2100	2100
Sound pressure level at a distance of 3 m [dBA]	24	24	24	24
Transported air temperature [°C]	-25...+40	-25...+40	-25...+40	-25...+40
Casing material	galvanized steel	galvanized steel	galvanized steel	galvanized steel
Insulation	40 mm mineral wool	40 mm mineral wool	40 mm mineral wool	40 mm mineral wool
Extract filter	G4	G4	G4	G4
Supply filter	G4+F7	G4+F7	G4+F7	G4+F7
Connected air duct diameter [mm]	160	160	160	160
Weight [kg]	63.1	64.3	63.1	64.3
Heat recovery efficiency [%]	80–98	80–98	74–89	74–89
Heat exchanger type	counter-flow	counter-flow	counter-flow	counter-flow
Heat exchanger material	polystyrene	polystyrene	enthalpy	enthalpy
SEC class	A+	A+	A	A

Sound power level, A-weighted	Total	Octave band [Hz]								LpA 3 m	LpA 1 m
		63	125	250	500	1000	2000	4000	8000		
LWA to supply inlet [dBA]	67	50	55	56	62	60	62	56	50		
LWA to supply outlet [dBA]	53	42	47	46	46	44	39	29	21		
LWA to exhaust inlet [dBA]	68	56	54	61	62	59	61	56	50		
LWA to exhaust outlet [dBA]	55	42	47	51	48	46	43	31	22		
LWA to environment [dBA]	45	34	35	40	39	32	36	31	27	24	34

*Data for point 1 in the performance diagram

Point	Power [W]	Sound pressure level at 3 m distance [dBA]
1	155	24 (34)
2	143	23 (33)
3	119	23 (33)
4	61	20 (30)
5	56	20 (30)
6	46	20 (30)
7	20	13 (23)
8	19	13 (23)
9	18	13 (23)

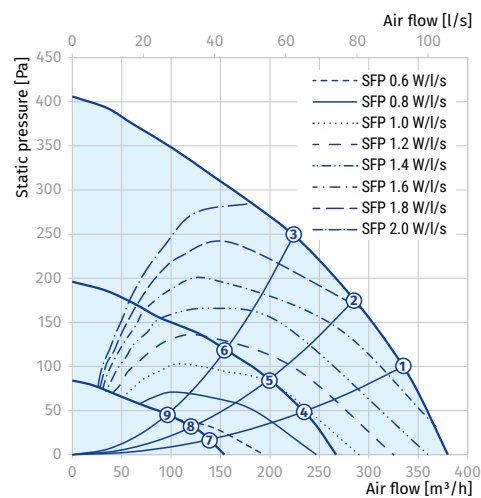

KOMFORT EC LB(E) 300

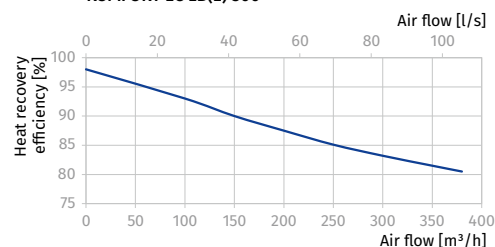

KOMFORT EC LB(E) 300-E

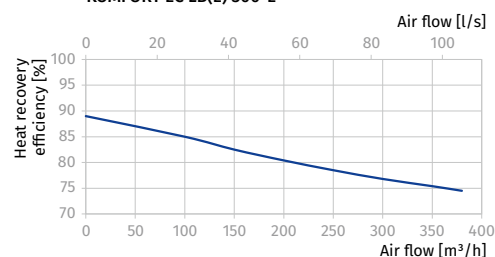

Technical data

Parameters	KOMFORT EC LB 400 S21 KOMFORT EC LB 400 S14	KOMFORT EC LBE 400 S21	KOMFORT EC LB 400-E S21 KOMFORT EC LB 400-E S14	KOMFORT EC LBE 400-E S21
Voltage [V / 50 (60) Hz]	1~ 230	1~ 230	1~ 230	1~ 230
Power (without a heater) [W]	289	289	289	289
Current (without a heater) [A]	2.1	2.1	2.1	2.1
Electric heater power [W]	-	2800	-	2800
Electric heater current [A]	-	12.2	-	12.2
Power (with a heater) [W]	289	3089	289	3089
Current (with a heater) [A]	2.1	14.3	2.1	14.3
Maximum air flow [m ³ /h (l/s)]	540 (150)	540 (150)	540 (150)	540 (150)
RPM [min ⁻¹]	2600	2600	2600	2600
Sound pressure level at a distance of 3 m [dBA]	27	27	27	27
Transported air temperature [°C]	-25...+40	-25...+40	-25...+40	-25...+40
Casing material	galvanized steel	galvanized steel	galvanized steel	galvanized steel
Insulation	40 mm mineral wool	40 mm mineral wool	40 mm mineral wool	40 mm mineral wool
Extract filter	G4	G4	G4	G4
Supply filter	G4+F7	G4+F7	G4+F7	G4+F7
Connected air duct diameter [mm]	200	200	200	200
Weight [kg]	74.8	76	74.8	76
Heat recovery efficiency [%]	84-98	84-98	78-89	78-89
Heat exchanger type	counter-flow	counter-flow	counter-flow	counter-flow
Heat exchanger material	polystyrene	polystyrene	enthalpy	enthalpy
SEC class	A+	A+	A	A

Sound power level, A-weighted	Total	Octave band [Hz]								LpA 3 m	LpA 1 m
		63	125	250	500	1000	2000	4000	8000		
L _{WA} to supply inlet [dBA]	71	52	57	57	68	64	64	59	53		
L _{WA} to supply outlet [dBA]	56	44	49	47	52	47	41	31	24		
L _{WA} to exhaust inlet [dBA]	70	52	56	60	66	62	64	60	53		
L _{WA} to exhaust outlet [dBA]	58	39	49	52	53	49	46	35	24		
L _{WA} to environment [dBA]	48	32	37	40	45	36	38	35	30	27	37

*Data for point 1 in the performance diagram

Point	Power [W]	Sound pressure level at 3 m distance [dBA]
1	240	27 (37)
2	215	26 (36)
3	196	26 (36)
4	89	21 (31)
5	80	21 (31)
6	72	20 (30)
7	27	19 (29)
8	26	19 (29)
9	24	17 (27)

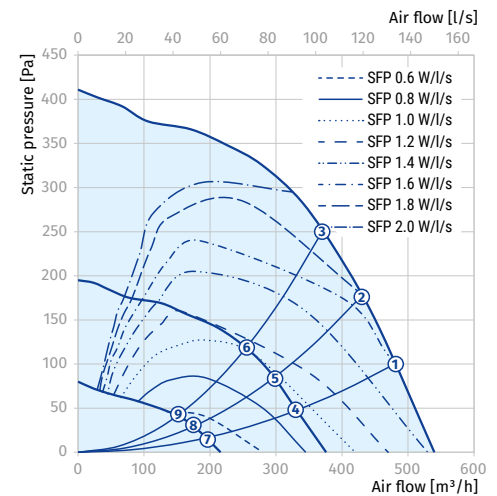
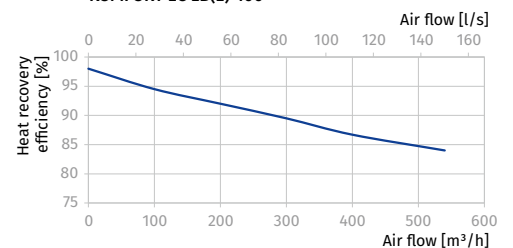
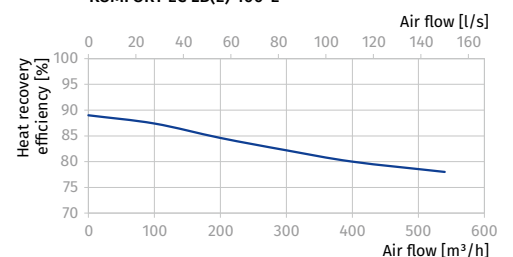
KOMFORT EC LB(E) 400

KOMFORT EC LB(E) 400-E

Technical data

Parameters	KOMFORT EC LB 700 S21 KOMFORT EC LB 700 S14	KOMFORT EC LBE 700 S21	KOMFORT EC LB 700-E S21 KOMFORT EC LB 700-E S14	KOMFORT EC LBE 700-E S21
Voltage [V / 50 (60) Hz]	1~ 230	1~ 230	1~ 230	1~ 230
Power (without a heater) [W]	336	336	336	336
Current (without a heater) [A]	2.4	2.4	2.4	2.4
Electric heater power [W]	-	3600	-	3600
Electric heater current [A]	-	15.6	-	15.6
Power (with a heater) [W]	336	3936	336	3936
Current (with a heater) [A]	2.4	18.0	2.4	18.0
Maximum air flow [m³/h (l/s)]	830 (231)	830 (231)	830 (231)	830 (231)
RPM [min⁻¹]	3200	3200	3200	3200
Sound pressure level at a distance of 3 m [dBA]	31	31	31	31
Transported air temperature [°C]	-25...+40	-25...+40	-25...+40	-25...+40
Casing material	galvanized steel	galvanized steel	galvanized steel	galvanized steel
Insulation	40 mm mineral wool	40 mm mineral wool	40 mm mineral wool	40 mm mineral wool
Extract filter	G4	G4	G4	G4
Supply filter	G4+F7	G4+F7	G4+F7	G4+F7
Connected air duct diameter [mm]	250	250	250	250
Weight [kg]	107	108.4	107	108.4
Heat recovery efficiency [%]	80–98	80–98	74–89	74–89
Heat exchanger type	counter-flow	counter-flow	counter-flow	counter-flow
Heat exchanger material	polystyrene	polystyrene	enthalpy	enthalpy
SEC class	A+	A+	A	A







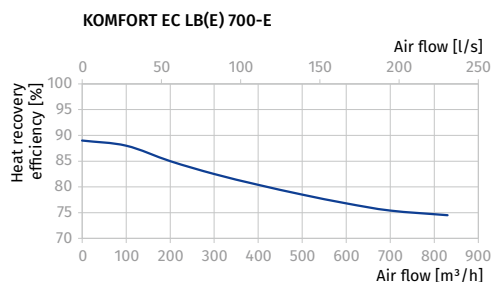
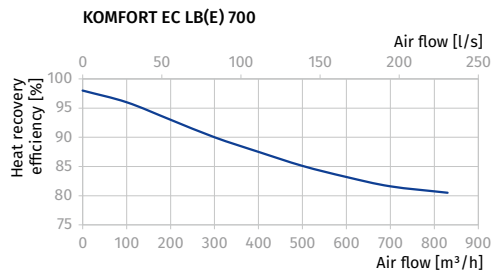
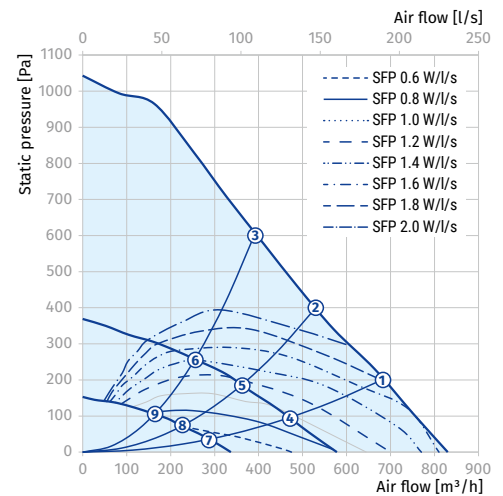













Sound power level, A-weighted	Total	Octave band [Hz]								LpA 3 m	LpA 1 m
		63	125	250	500	1000	2000	4000	8000		
LWA to supply inlet [dBA]	76	56	61	61	73	69	69	64	57		
LWA to supply outlet [dBA]	60	49	53	52	56	51	44	34	26		
LWA to exhaust inlet [dBA]	74	56	60	65	70	66	68	64	56		
LWA to exhaust outlet [dBA]	61	42	53	56	56	52	49	37	25		
LWA to environment [dBA]	51	35	40	43	49	39	40	37	32	31	41

*Data for point 1 in the performance diagram





















Point	Power [W]	Sound pressure level at 3 m distance [dBA]
1	336	31 (41)
2	336	30 (40)
3	336	29 (39)
4	123	25 (35)
5	115	25 (35)
6	96	24 (34)
7	41	23 (33)
8	38	23 (33)
9	36	20 (30)



Accessories

		KOMFORT EC LB 300(-E) S21	KOMFORT EC LB 300(-E) S14	KOMFORT EC LBE 300(-E) S21
Panel filter G4		FP 484x178x48 G4	FP 484x178x48 G4	FP 484x178x48 G4
Panel filter F7		FP 484x178x48 F7	FP 484x178x48 F7	FP 484x178x48 F7
Control panel		S22	-	S22
Wireless control panel		S22 Wi-Fi	-	S22 Wi-Fi
LCD control panel		S25	-	S25
Indoor humidity sensor		FS2	FS2	FS2
CO ₂ sensor with indication		CD-1	CD-1	CD-1
CO ₂ sensor		CD-2	CD-2	CD-2
Humidity sensor		HR-S	HR-S	HR-S
VOC sensor		DPWQ30600	-	DPWQ30600
CO ₂ sensor		DPWQ40200	-	DPWQ40200
Humidity sensor		DPWC11200	-	DPWC11200
Reheater		ENH 160	-	-
Preheater		EVH 160	-	EVH 160
Silencer		SD 160	SD 160	SD 160
Non-return valve		VRV 160	VRV 160	VRV 160
Air damper		VKA 160	VKA 160	VKA 160
Drain pump		CP-2	CP-2	CP-2
Air damper actuator		LF230	LF230	LF230
Air damper actuator		TF230	TF230	TF230

		KOMFORT EC LB 400(-E) S21	KOMFORT EC LB 400(-E) S14	KOMFORT EC LBE 400(-E) S21
Panel filter G4		FP 600x205x48 G4	FP 600x205x48 G4	FP 600x205x48 G4
Panel filter F7		FP 600x205x48 F7	FP 600x205x48 F7	FP 600x205x48 F7
Control panel		S22	-	S22
Wireless control panel		S22 Wi-Fi	-	S22 Wi-Fi
LCD control panel		S25	-	S25
Indoor humidity sensor		FS2	FS2	FS2
CO ₂ sensor with indication		CD-1	CD-1	CD-1
CO ₂ sensor		CD-2	CD-2	CD-2
Humidity sensor		HR-S	HR-S	HR-S
VOC sensor		DPWQ30600	-	DPWQ30600
CO ₂ sensor		DPWQ40200	-	DPWQ40200
Humidity sensor		DPWC11200	-	DPWC11200
Reheater		ENH 200	-	-
Preheater		EVH 200	-	EVH 200
Silencer		SD 200	SD 200	SD 200
Non-return valve		VRV 200	VRV 200	VRV 200
Air damper		VKA 200	VKA 200	VKA 200
Drain pump		CP-2	CP-2	CP-2
Air damper actuator		TF230	TF230	TF230
Air damper actuator		TF230	TF230	TF230

		KOMFORT EC LB 700(-E) S21	KOMFORT EC LB 700(-E) S14	KOMFORT EC LBE 700(-E) S21
Panel filter G4		FP 784x253x48 G4	FP 784x253x48 G4	FP 784x253x48 G4
Panel filter F7		FP 784x253x48 F7	FP 784x253x48 F7	FP 784x253x48 F7
Control panel		S22	-	S22
Wireless control panel		S22 Wi-Fi	-	S22 Wi-Fi
LCD control panel		S25	-	S25
Indoor humidity sensor		FS2	FS2	FS2
CO ₂ sensor with indication		CD-1	CD-1	CD-1
CO ₂ sensor		CD-2	CD-2	CD-2
Humidity sensor		HR-S	HR-S	HR-S
VOC sensor		DPWQ30600	-	DPWQ30600
CO ₂ sensor		DPWQ40200	-	DPWQ40200
Humidity sensor		DPWC11200	-	DPWC11200
Reheater		ENH 250	-	-
Preheater		EVH 250	-	EVH 250
Silencer		SD 250	SD 250	SD 250
Non-return valve		VRV 250	VRV 250	VRV 250
Air damper		VKA 250	VKA 250	VKA 250
Drain pump		CP-2	CP-2	CP-2
Air damper actuator		LF230	LF230	LF230
Air damper actuator		TF230	TF230	TF230

KOMFORT L

Heat recovery air handling units

Features

- Air handling units for efficient supply and exhaust ventilation in flats, houses, cottages and other buildings.
- Heat recovery minimises ventilation heat losses.
- Control of air exchange for creating comfortable indoor microclimate.
- Compatible with round Ø 125 to 315 mm air ducts.



Air flow:
up to 2200 m³/h
611 l/s



Heat recovery efficiency:
up to 88 %



Design

- The casing is made of aluminium profile and double-skinned aluzinc panels, internally filled with mineral wool layer for heat and sound insulation.
- The casing has fixing brackets with vibration absorbing connectors for easy installation.
- The spigots for connection to the air ducts are located at the side of the unit and are rubber sealed for airtight connection to the air ducts.
- The hinged casing side panels ensure easy access to the internals for cleaning, filter replacement and other maintenance operations.

Fans

- Asynchronous external rotor motors and centrifugal double-intake impellers with forward curved blades are used for air supply and exhaust.
- Integrated motor overheating protection with automatic restart.
- Dynamically balanced impellers.
- Equipped with ball bearings for longer service life.
- Reliable and quiet operation.

KOMFORT L 350/500/530/600

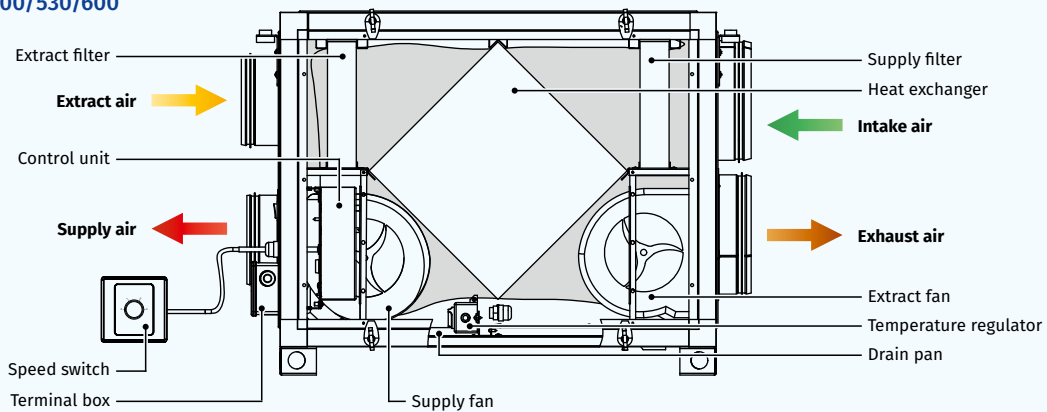

KOMFORT L 1200/2200

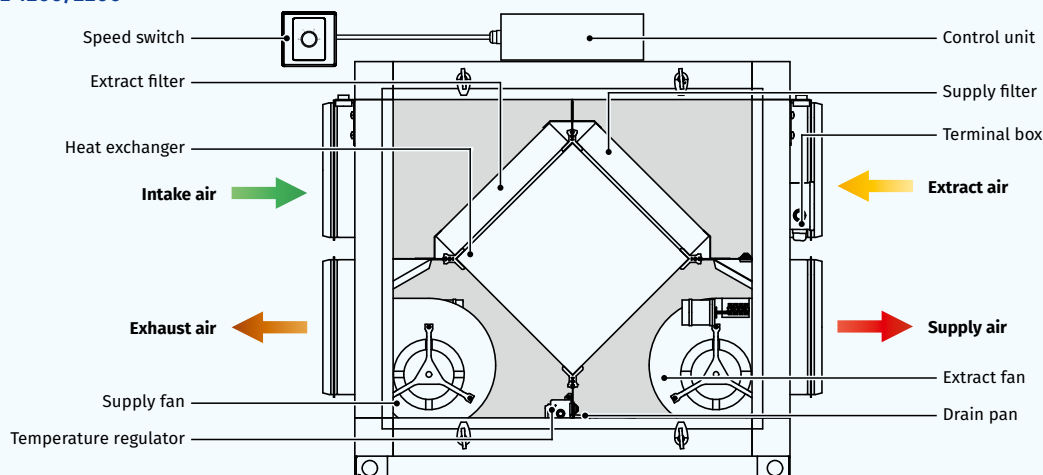

Heat recovery

- The unit is equipped with a plate cross-flow poly-styrene heat exchanger for heat recovery. The unit condensate is collected and drained to the drain pan under the heat exchanger.

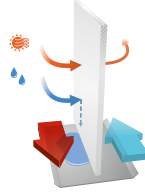

- The air flows are completely separated in the heat exchanger. Thus smells and contaminants are not transferred from the extract air to the supply air.
- Heat recovery is based on heat and/or humidity transfer through the heat exchanger plates. In the cold season supply air is heated in the heat exchanger by transferring the heat energy of warm and humid extract air to the cold fresh air. Heat recovery minimizes ventilation heat losses and heating costs respectively.
- In the warm season the heat exchanger performs reverse and intake air is cooled in the heat exchanger by the cool extract air. That reduces operation load on air conditioners and saves electricity.
- When the indoor and outdoor temperature difference is insignificant, heat recovery is not reasonable. In this case the heat exchanger can be temporary replaced with a summer block for the warm season (available as a specially ordered accessory).

Air filtration

- The built-in G4 supply filter and G4 extract filter provide air filtration.

Control and automation

- Speed control by means of the four-position speed switch CDP-3/5 that enables setting low, medium, maximum speed and turning the unit off.

Mounting

- Mounting to floor, ceiling or wall with fixing brackets.
- The correct mounted unit must provide condensate collecting and drainage and free access to the hinged side panel for servicing and filter replacement.

FREEZE PROTECTION

- The integrated automatic freeze protection is used to prevent freezing of the heat exchanger in the cold season. The supply fan turns off according to the temperature sensor to get the heat exchanger warmed up with extract air. After that the supply fan turns on and the unit continues to run in the standard mode.

Designation key

Series	Spigot modification	Rated air flow [m³/h]
KOMFORT	L: horizontal spigot orientation	350; 500; 530; 600; 1200; 2200

Overall dimensions [mm]

Model	D	B	H	L	L1
KOMFORT L 350	124	416	603	722	768
KOMFORT L 500	149	416	603	722	768
KOMFORT L 530	159	416	603	722	768
KOMFORT L 600	199	416	603	722	768
KOMFORT L 1200	248	548	794	802	850
KOMFORT L 2200	313	846	968	1000	1050

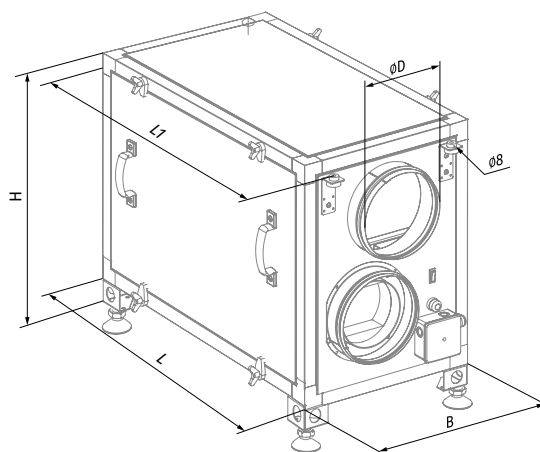

Technical data

Parameters	KOMFORT L 350	KOMFORT L 500	KOMFORT L 530	KOMFORT L 600	KOMFORT L 1200	KOMFORT L 2200
Voltage [V / 50 (60) Hz]	1 ~ 230	1 ~ 230	1 ~ 230	1 ~ 230	1 ~ 230	1 ~ 230
Power [W]	260	300	300	390	820	1300
Current [A]	1.2	1.32	1.32	1.72	3.6	5.68
Maximum air flow [m ³ /h (l/s)]	350 (97)	500 (139)	530 (147)	600 (167)	1200 (333)	2200 (611)
RPM [min ⁻¹]	1150	1100	1100	1350	1850	1150
Sound pressure level at 3 m [dBA]	24-45	28-47	28-47	32-48	60	65
Transported air temperature [°C]	-25...+40	-25...+40	-25...+40	-25...+40	-25...+40	-25...+40
Casing material	aluzinc	aluzinc	aluzinc	aluzinc	aluzinc	aluzinc
Insulation	25 mm mineral wool	25 mm mineral wool	25 mm mineral wool	25 mm mineral wool	50 mm mineral wool	50 mm mineral wool
Extract filter	G4	G4	G4	G4	G4	G4
Supply filter	G4	G4	G4	G4	G4	G4
Connected air duct diameter [mm]	125	150	160	200	250	315
Weight [kg]	45	49	49	54	85	96
Heat recovery efficiency [%]*	up to 78	up to 88	up to 88	up to 85	up to 88	up to 87
Heat exchanger type	cross-flow	cross-flow	cross-flow	cross-flow	cross-flow	cross-flow
Heat exchanger material	polystyrene	polystyrene	polystyrene	polystyrene	polystyrene	polystyrene
SEC class	E	E	E	E	NRVU**	NRVU**
ErP	2016	2016	2016	2016	-	-

*Heat recovery efficiency is specified in compliance with the EN308 EU norms.

**Nonresidential Ventilation Unit.

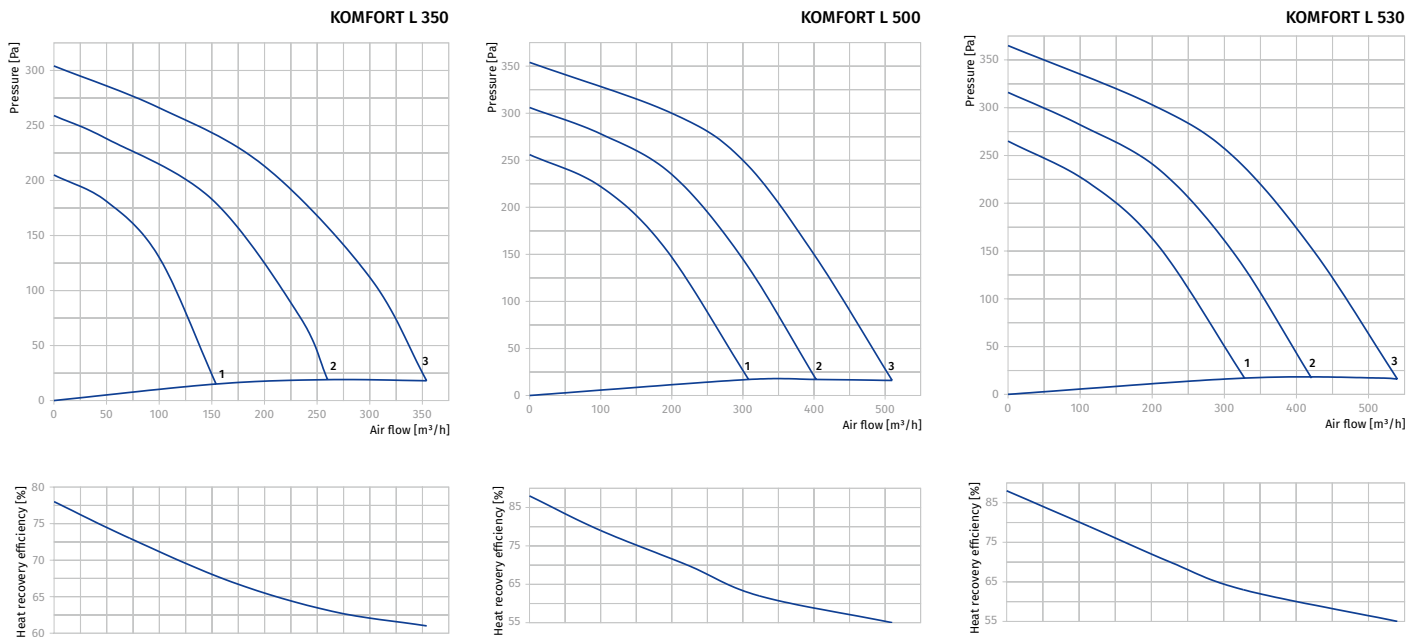

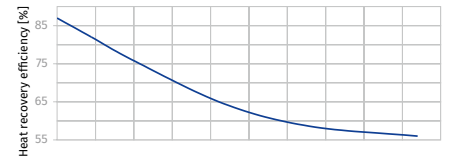
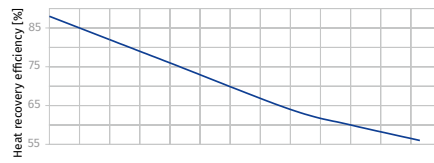
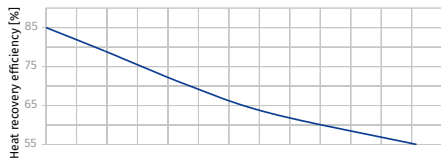
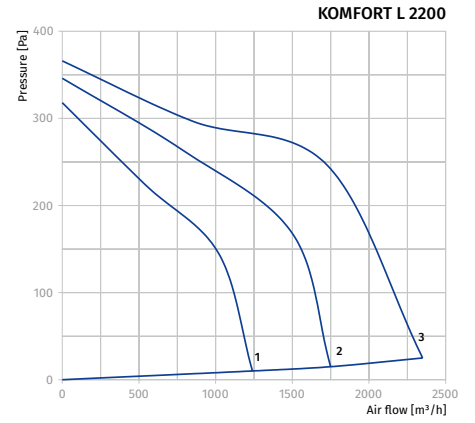
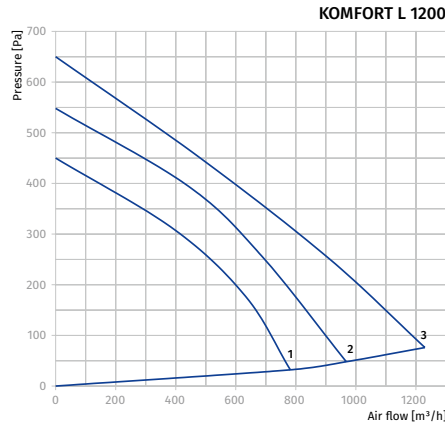
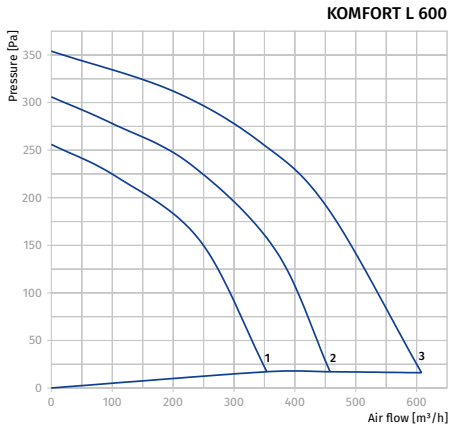

Accessories

		KOMFORT L 350	KOMFORT L 500	KOMFORT L 530	KOMFORT L 600	KOMFORT L 1200	KOMFORT L 2200
G4 panel filter		FP 378x210x47 G4	FP 436x215x48 G4	FP 436x215x48 G4	FP 436x215x48 G4	FP 450x295x48 G4	FP 750x295x48 G4
Silencer		SD 125	SD 150	SD 160	SD 200	SD 250	SD 315
Backdraft air damper		VRV 125	VRV 150	VRV 160	VRV 200	VRV 250	VRV 315
Air damper		VK 125	VK 150	VK 160	VK 200	VK 250	VK 315
Summer block		SB C4 200/384	SB C4 300/384	SB C4 300/384	SB C4 300/384	SB C4 300/450	SB C4 300/750

HEAT RECOVERY AIR HANDLING UNITS

KOMFORT LE

Heat recovery air handling units

Features

- Air handling units for efficient supply and exhaust ventilation in flats, houses, cottages and other buildings.
- Heat recovery minimises ventilation heat losses.
- Control of air exchange for creating comfortable indoor microclimate.
- Compatible with round Ø 125 to 315 mm air ducts.



Air flow:
up to 2200 m³/h
611 l/s



Heat recovery efficiency:
up to 88 %



Design

- The casing is made of double-skinned aluzinc panels, internally filled with 25 mm mineral wool layer for heat and sound insulation.
- The casing has fixing brackets with vibration absorbing connectors for easy installation.
- The spigots for connection to the air ducts are located at the side of the unit and are rubber sealed for airtight connection to the air ducts.
- The hinged casing side panels ensure easy access to the internals for cleaning, filter replacement and other maintenance operations.

Fans

- Asynchronous external rotor motors and centrifugal double-intake impellers with forward curved blades are used for air supply and exhaust.
- Integrated motor overheating protection with automatic restart.
- Dynamically balanced impellers.
- Equipped with ball bearings for longer service life.
- Reliable and quiet operation.

KOMFORT LE 350-3... KOMFORT LE 600-4

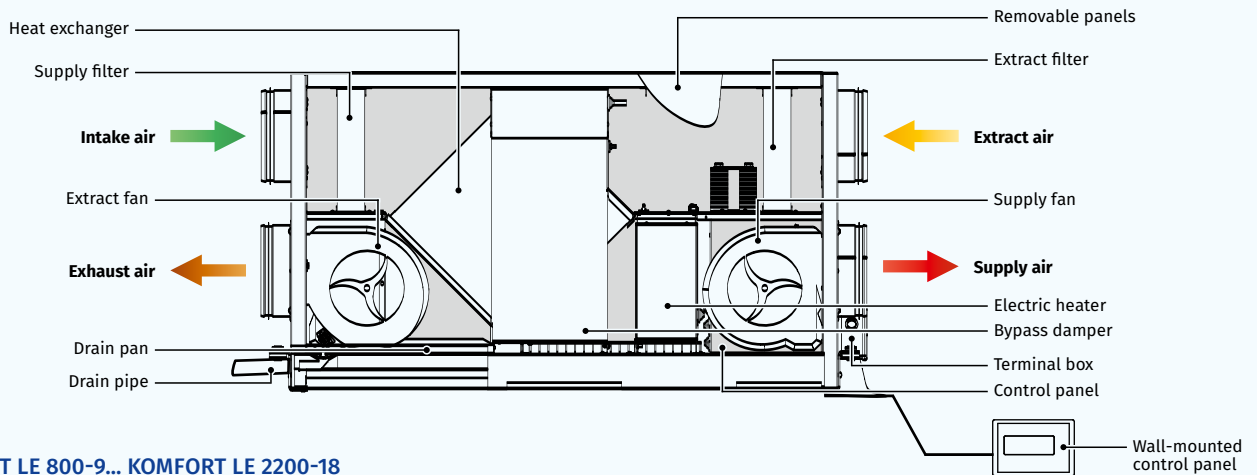

KOMFORT LE 800-9... KOMFORT LE 2200-18

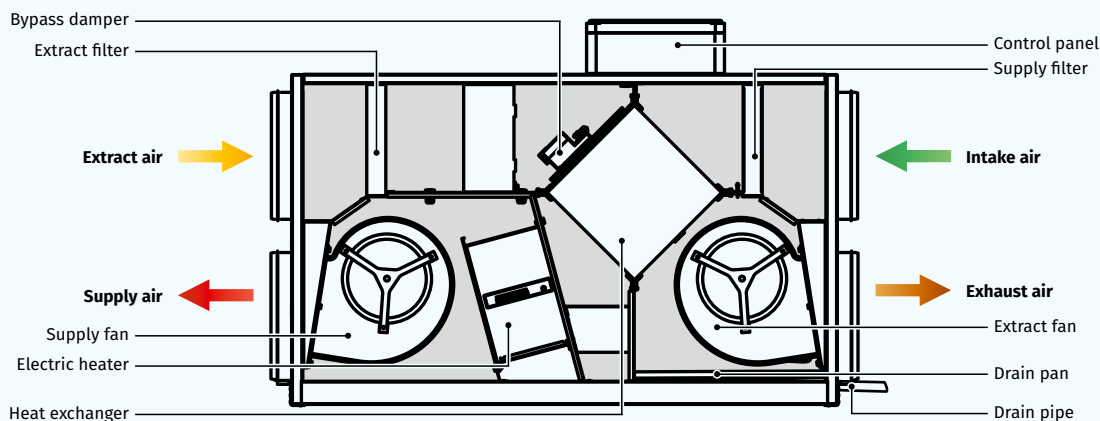

Heat recovery

- The unit is equipped with a plate cross-flow polystyrene heat exchanger for heat recovery. The unit condensate is collected and drained to the drain pan under the heat exchanger.

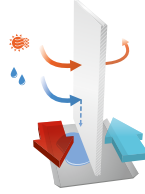

- The air flows are completely separated in the heat exchanger. Thus smells and contaminants are not transferred from the extract air to the supply air.
- Heat recovery is based on heat and/or humidity transfer through the heat exchanger plates. In the cold season supply air is heated in the heat exchanger by transferring the heat energy of warm and humid extract air to the cold fresh air. Heat recovery minimizes ventilation heat losses and heating costs respectively.
- In the warm season the heat exchanger performs reverse and intake air is cooled in the heat exchanger by the cool extract air. That reduces operation load on air conditioners and saves electricity.
- When the indoor and outdoor temperature difference is insignificant, heat recovery is not reasonable. In this case the heat exchanger can be temporarily replaced with a summer block for the warm season (available as a specially ordered accessory).

FREEZE PROTECTION

- The electronic protection system based on bypass and heater is used for freezing protection of the unit in cold seasons. The bypass damper is opened and the heater is turned on automatically according to temperature sensor readings. Cold intake air passes by the heat exchanger and is warmed up to set temperature in the heat exchanger. Synchronously extract air that passes by the heat exchanger is used for its defrosting. After a freezing danger is over the bypass damper is closed, the heater is turned off. The heat exchanger reverts to the normal operation mode.

Air heater

- The unit is equipped with an electric heater for operation during cold seasons at low outside temperature.
- The integrated electric heater is activated to warm up supply air flow if set indoor air temperature may not be reached by means of heat recovery only.
- Smooth heat output control ensures automatic supply air temperature maintaining.
- Two integrated overheat protection thermostats, one actuated at +60 °C with automatic restart and the other one actuated at +90 °C with manual restart.

Designation key

Series	Spigot modification	Heater type
KOMFORT	L: horizontal spigot orientation	E: electric heater

Rated air flow [m³/h]	Heater power [kW]
350; 500; 530; 600; 800; 1200; 1700; 2200	- 3; 4; 9; 18

Overall dimensions [mm]

Model	∅ D	B	B1	H	H1	L	L1	L2
KOMFORT LE 350-3	124	497	403	554	-	954	996	1057
KOMFORT LE 500-3	149	497	403	554	-	954	996	1057
KOMFORT LE 530-4	159	497	403	554	-	954	996	1057
KOMFORT LE 600-4	199	497	403	554	-	954	996	1057
KOMFORT LE 800-9	249	613	460	698	832	1071	1117	1176
KOMFORT LE 1200-9	249	613	460	698	832	1071	1117	1176
KOMFORT LE 1700-18	314	842	581	814	947	1345	1394	1447
KOMFORT LE 2200-18	314	842	581	814	947	1345	1394	1447

Air filtration

- The built-in G4 supply filter and G4 extract filter provide air filtration.

Control and automation

- The unit incorporates an integrated control system with a wall-mounted control panel and LCD display.
- The standard delivery set includes a 10 m cable for connection of the unit and the control panel.
- Control panel functions:**
 - Switching on/off.
 - Three-speed fan selection, selecting heating/cooling modes (if connected to duct heater).
 - Temperature display.
- Automation functions:**
 - Maintaining supply air temperature set from the control panel by controlling the circulation pump and actuating the heat medium regulating valve; input from the heat medium flow switch (pump alarm);
 - Safe start-up/ shutdown of the fans, warming up of the water heater before start-up; return heat medium temperature control when the fan is off.
 - Freezing protection of the water heating coils by the exhaust temperature sensor and the return heat medium temperature sensor.
 - Control of the compressor and condensing unit of the water cooler by the room temperature sensor (for the models equipped with a duct air cooler);
 - Actuating the external air dampers with a return spring
 - Unit operation according to week schedule (set at the system setup).
 - Unit shut down at signal from the fire alarm system.
 - Smooth bypass damper control in the bypassing mode to prevent the heat exchanger freezing.

Mounting

- Mounting to floor, ceiling or wall with fixing brackets.
- The correct mounted unit must provide condensate collecting and drainage and free access to the hinged side panel for servicing and filter replacement.

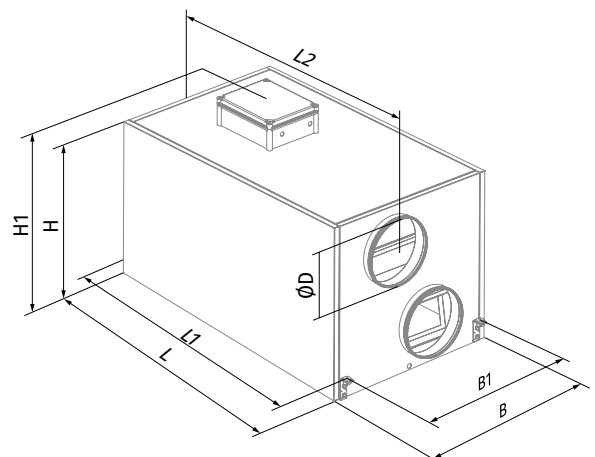

Technical data

Parameters	KOMFORT LE 350-3	KOMFORT LE 500-3
Voltage [V / 50 (60) Hz]	1 ~ 230	1 ~ 230
Power [W]	3260	3300
Heater power [W]	3000	3000
Power without heater [W]	260	300
Current [A]	14.2	14.32
Electric heater current [A]	13	13
Current without heater [A]	1.2	1.32
Maximum air flow [m ³ /h (l/s)]	350 (97)	500 (139)
RPM [min ⁻¹]	1150	1100
Sound pressure level at 3 m [dBA]	24-45	24-47
Transported air temperature [°C]	-25...+40	-25...+40
Casing material	aluzinc	aluzinc
Insulation	25 mm mineral wool	25 mm mineral wool
Extract filter	G4	G4
Supply filter	G4	G4
Connected air duct diameter [mm]	125	150
Weight [kg]	45	49
Heat recovery efficiency [%]*	up to 78	up to 88
Heat exchanger type	cross-flow	cross-flow
Heat exchanger material	polystyrene	polystyrene
SEC class	E	E
ErP	2016	2016

*Heat recovery efficiency is specified in compliance with the EN308 EU norms.

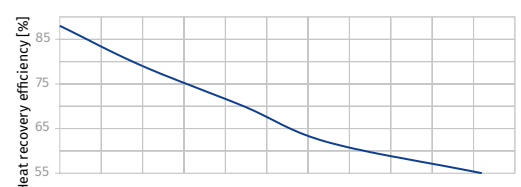
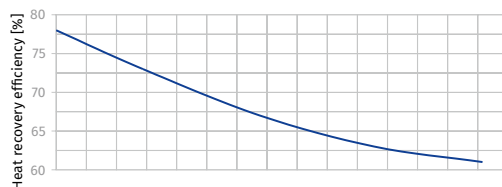
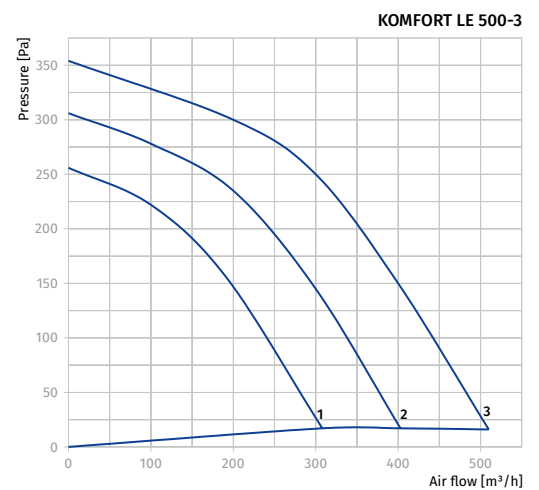
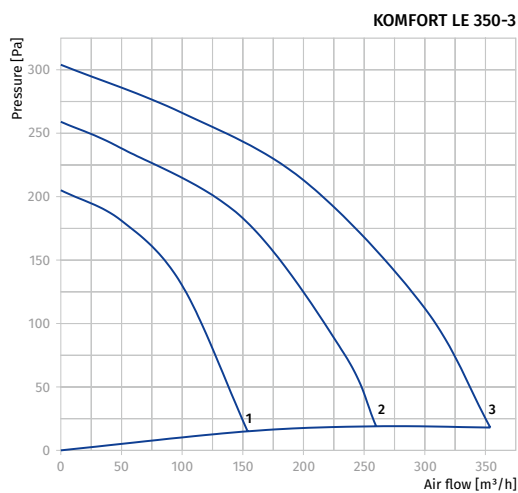

Parameters	KOMFORT LE 530-4	KOMFORT LE 600-4
Voltage [V / 50 (60) Hz]	1 ~ 230	1 ~ 230
Power [W]	4300	4390
Heater power [W]	4000	4000
Power without heater [W]	300	390
Current [A]	18.72	19.1
Electric heater current [A]	17.4	17.4
Current without heater [A]	1.32	1.72
Maximum air flow [m³/h (l/s)]	530 (147)	600 (167)
RPM [min ⁻¹]	1100	1350
Sound pressure level at 3 m [dBA]	28-47	32-48
Transported air temperature [°C]	-25...+40	-25...+40
Casing material	aluzinc	aluzinc
Insulation	25 mm mineral wool	25 mm mineral wool
Extract filter	G4	G4
Supply filter	G4	G4
Connected air duct diameter [mm]	160	200
Weight [kg]	49	54
Heat recovery efficiency [%]*	up to 88	up to 85
Heat exchanger type	cross-flow	cross-flow
Heat exchanger material	polystyrene	polystyrene
SEC class	E	E
ErP	2016	2016

*Heat recovery efficiency is specified in compliance with the EN308 EU norms.

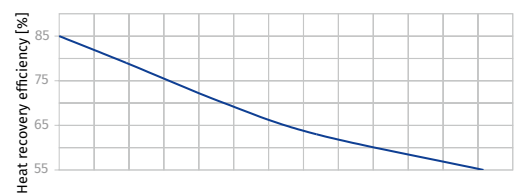
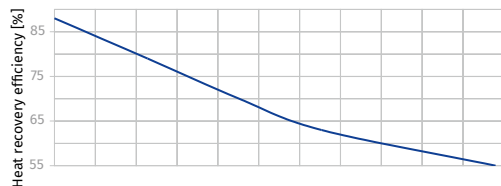
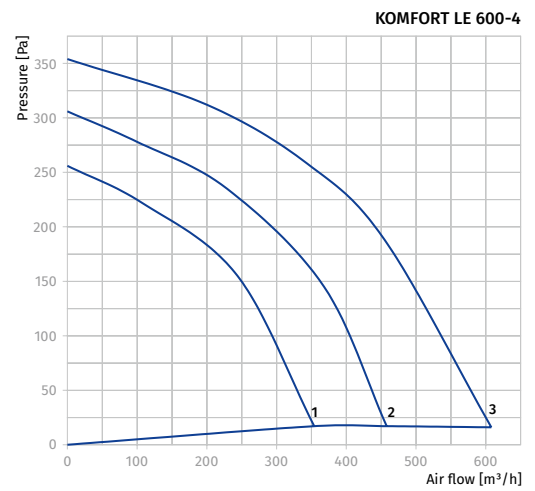
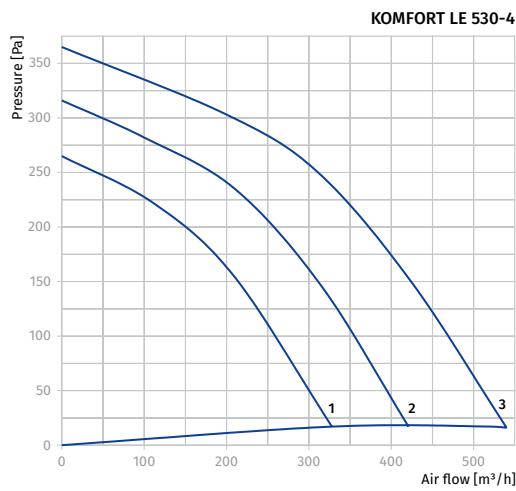

Parameters	KOMFORT LE 800-9	KOMFORT LE 1200-9
Voltage [V / 50 (60) Hz]	3 ~400	3 ~400
Power [W]	9490	9800
Heater power [W]	9000	9000
Power without heater [W]	490	800
Current [A]	15.16	16.6
Electric heater current [A]	13.0	13.0
Current without heater [A]	2.16	3.6
Maximum air flow [m³/h (l/s)]	800 (222)	1200 (333)
RPM [min ⁻¹]	1650	1850
Sound pressure level at 3 m [dBA]	48	60
Transported air temperature [°C]	-25...+40	-25...+40
Casing material	aluzinc	aluzinc
Insulation	25 mm mineral wool	25 mm mineral wool
Extract filter	G4	G4
Supply filter	G4	G4
Connected air duct diameter [mm]	250	250
Weight [kg]	85	85
Heat recovery efficiency [%]*	up to 78	up to 78
Heat exchanger type	cross-flow	cross-flow
Heat exchanger material	polystyrene	polystyrene
SEC class	E	NRVU**
ErP	2016	-

*Heat recovery efficiency is specified in compliance with the EN308 EU norms.

**Nonresidential Ventilation Unit.

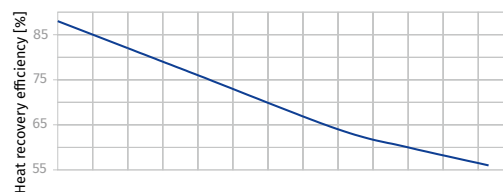
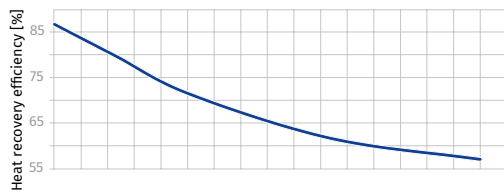
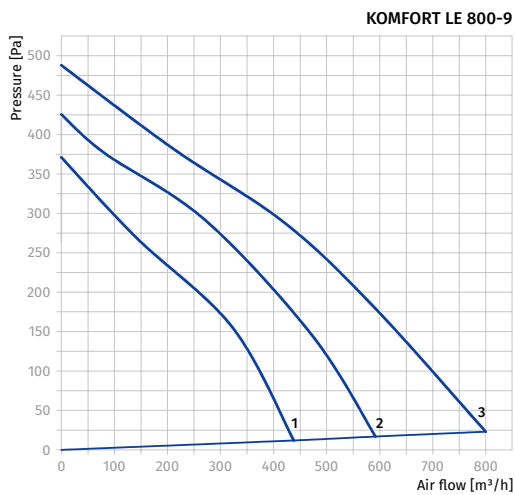

Parameters	KOMFORT LE 1700-18	KOMFORT LE 2200-18
Voltage [V / 50 (60) Hz]	3 ~ 400	3 ~ 400
Power [W]	18980	19300
Heater power [W]	18000	18000
Power without heater [W]	980	1300
Current [A]	30.3	31.7
Electric heater current [A]	26	26
Current without heater [A]	4.3	5.7
Maximum air flow [m³/h (l/s)]	1750 (486)	2200 (611)
RPM [min ⁻¹]	1100	1150
Sound pressure level at 3 m [dBA]	49	65
Transported air temperature [°C]	-25...+40	-25...+40
Casing material	aluzinc	aluzinc
Insulation	25 mm mineral wool	25 mm mineral wool
Extract filter	G4	G4
Supply filter	G4	G4
Connected air duct diameter [mm]	315	315
Weight [kg]	96	96
Heat recovery efficiency [%]*	up to 77	up to 77
Heat exchanger type	cross-flow	cross-flow
Heat exchanger material	polystyrene	polystyrene
SEC class	NRVU**	NRVU**
ErP	-	-

*Heat recovery efficiency is specified in compliance with the EN308 EU norms.

**Nonresidential Ventilation Unit.

HEAT RECOVERY AIR HANDLING UNITS

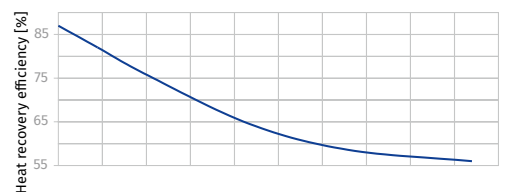
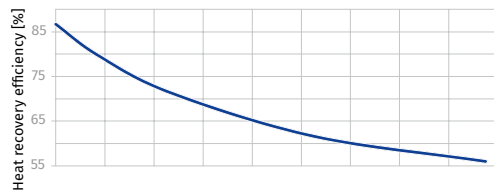
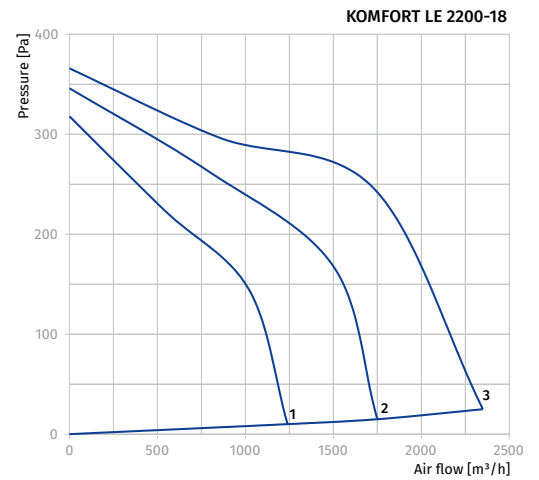
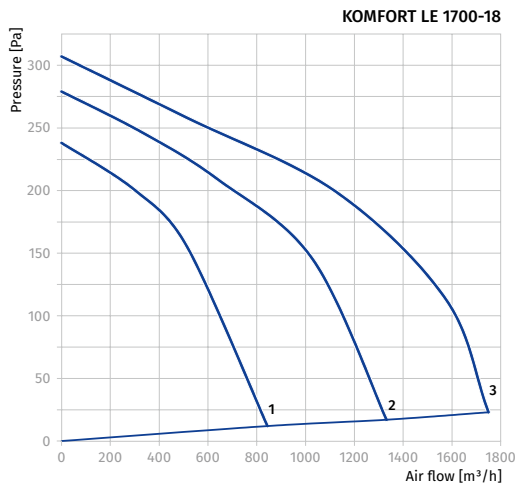

Accessories

		KOMFORT LE 350-3	KOMFORT LE 500-3	KOMFORT LE 530-4	KOMFORT LE 600-4
G4 panel filter		FP 438x215x48 G4	FP 438x215x48 G4	FP 438x215x48 G4	FP 438x215x48 G4
Silencer		SD 125	SD 150	SD 160	SD 200
Silencer		SDF 125	SDF 150	SDF 160	SDF 200
Backdraft air damper		VRV 125	VRV 150	VRV 160	VRV 200
Air damper		VK 125	VK 150	VK 160	VK 200
Summer block		SB C4 300/300	SB C4 300/300	SB C4 300/300	SB C4 300/300

		KOMFORT LE 800-9	KOMFORT LE 1200-9	KOMFORT LE 1700-18	KOMFORT LE 2200-18
G4 panel filter		FP 550x253x48 G4	FP 550x253x48 G4	FP 780x273x48 G4	FP 780x273x48 G4
Silencer		SD 250	SD 250	SD 315	SD 315
Silencer		SDF 250	SDF 250	SDF 315	SDF 315
Backdraft air damper		VRV 250	VRV 250	VRV 315	VRV 315
Air damper		VK 250	VK 250	VK 315	VK 315
Summer block		SB C4 300/384	SB C4 300/384	SB C4 300/300 (2 pcs.)	SB C4 300/300 (2 pcs.)

KOMFORT LW

Heat recovery air handling units

Features

- Air handling units for efficient supply and exhaust ventilation in flats, houses, cottages and other buildings.
- Heat recovery minimises ventilation heat losses.
- Control of air exchange for creating comfortable indoor microclimate.
- Compatible with round Ø 250 to 315 mm air ducts.



Air flow:
up to 2100 m³/h
583 l/s



Heat recovery efficiency:
up to 78 %



Design

- The casing is made of double-skinned aluzinc panels, internally filled with 50 mm mineral wool layer for heat and sound insulation.
- The casing has fixing brackets with vibration absorbing connectors for easy installation.
- The spigots for connection to the air ducts are located at the side of the unit and are rubber sealed for airtight connection to the air ducts.
- The hinged casing side panels ensure easy access to the internals for cleaning, filter replacement and other maintenance operations.

Fans

- Asynchronous external rotor motors and centrifugal double-intake impellers with forward curved blades are used for air supply and exhaust.
- Integrated motor overheating protection with automatic restart.
- Dynamically balanced impellers.
- Equipped with ball bearings for longer service life.
- Reliable and quiet operation.

HEAT RECOVERY AIR HANDLING UNITS

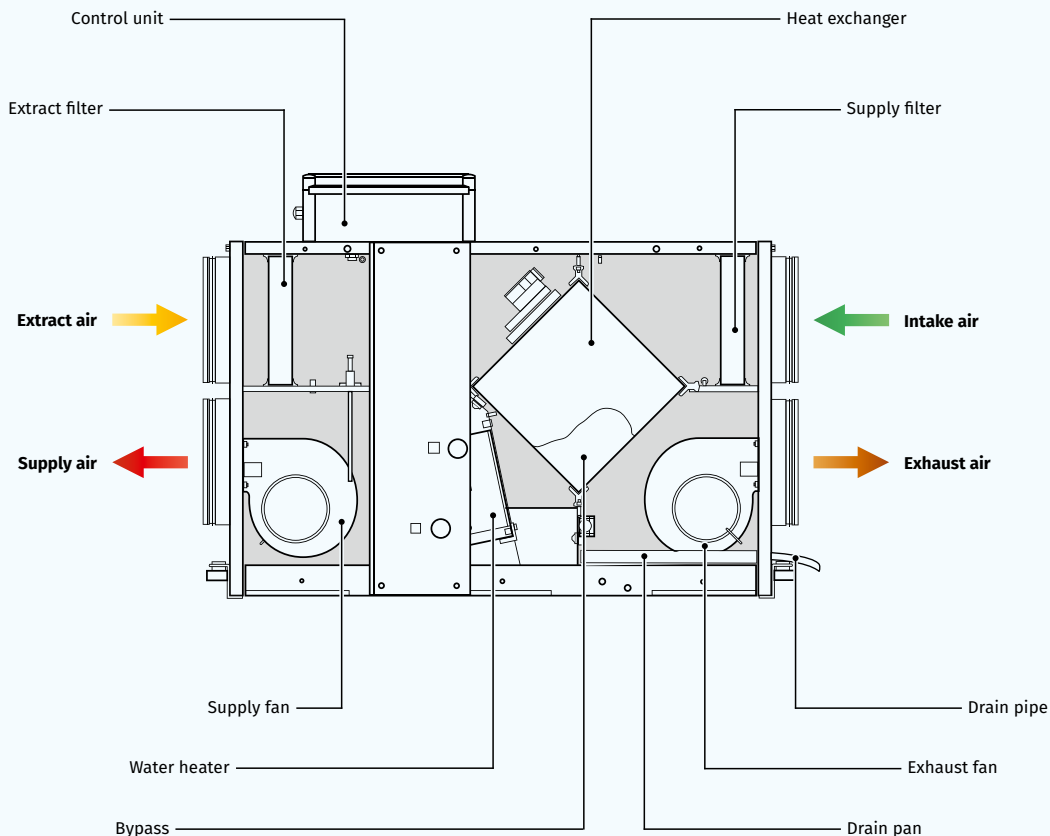

Heat recovery

- The unit is equipped with a plate cross-flow polystyrene heat exchanger for heat recovery. The unit condensate is collected and drained to the drain pan under the heat exchanger.

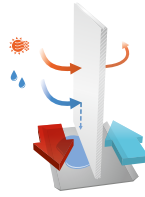

- The air flows are completely separated in the heat exchanger. Thus smells and contaminants are not transferred from the extract air to the supply air.
- Heat recovery is based on heat and/or humidity transfer through the heat exchanger plates. In the cold season supply air is heated in the heat exchanger by transferring the heat energy of warm and humid extract air to the cold fresh air. Heat recovery minimizes ventilation heat losses and heating costs respectively.
- In the warm season the heat exchanger performs reverse and intake air is cooled in the heat exchanger by the cool extract air. That reduces operation load on air conditioners and saves electricity.
- When the indoor and outdoor temperature difference is insignificant, heat recovery is not reasonable. In this case the heat exchanger can be temporarily replaced with a summer block for the warm season (available as a specially ordered accessory).

FREEZE PROTECTION

- The electronic protection system based on bypass and heater is used for freezing protection of the unit in cold seasons. The bypass damper is opened and the heater is turned on automatically according to temperature sensor readings. Cold intake air passes by the heat exchanger and is warmed up to set temperature in the heat exchanger. Synchronously extract air that passes by the heat exchanger is used for its defrosting. After a freezing danger is over the bypass damper is closed, the heater is turned off. The heat exchanger reverts to the normal operation mode.

Air heater

- The unit is equipped with a water (glycol) heater for operation at low outside air temperature.
- The integrated water heater is activated to warm up supply air flow if set indoor air temperature may not be reached by means of heat recovery only.
- Heat medium temperature control ensures supply air temperature maintaining.
- The air temperature sensor downstream of the waterheating coils and the return water temperature sensor are used for freezing protection of the water heater.

Designation key

Series	Spigot modification	Heater type	Rated air flow [m³/h]	Number of water heater rows
KOMFORT	L: horizontal spigot orientation	W: water heater	800; 1100; 1700; 2100	- 4

Overall dimensions [mm]

Model	D	B	B1	H	L	L1	L2
KOMFORT LW 800-4	249	613	460	698	1071	1117	1171
KOMFORT LW 1100-4	249	613	460	698	1071	1117	1171
KOMFORT LW 1700-4	314	842	581	814	1345	1388	1445
KOMFORT LW 2100-4	314	842	581	814	1345	1388	1445

Air filtration

- The built-in G4 supply filter and G4 extract filter provide air filtration.

Control and automation

- The unit incorporates an integrated control system with a wall-mounted control panel and LCD display.
- The standard delivery set includes a 10 m cable for connection of the unit and the control panel.
- Control panel functions:**
 - Switching on/off.
 - Three-speed fan selection, selecting heating/cooling modes (if connected to duct heater).
 - Temperature display.
- Automation functions:**
 - Maintaining supply air temperature set from the control panel by controlling the circulation pump and actuating the heat medium regulating valve; input from the heat medium flow switch (pump alarm);
 - Safe start-up/ shutdown of the fans, warming up of the water heater before start-up; return heat medium temperature control when the fan is off.
 - Freezing protection of the water heating coils by the exhaust temperature sensor and the return heat medium temperature sensor.
 - Control of the compressor and condensing unit of the water cooler by the room temperature sensor (for the models equipped with a duct air cooler);
 - Actuating the external air dampers with a return spring
 - Unit operation according to week schedule (set at the system setup).
 - Unit shut down at signal from the fire alarm system.
 - Smooth bypass damper control in the bypassing mode to prevent the heat exchanger freezing.

Mounting

- Mounting to floor, ceiling or wall with fixing brackets.
- The correct mounted unit must provide condensate collecting and drainage and free access to the hinged side panel for servicing and filter replacement.

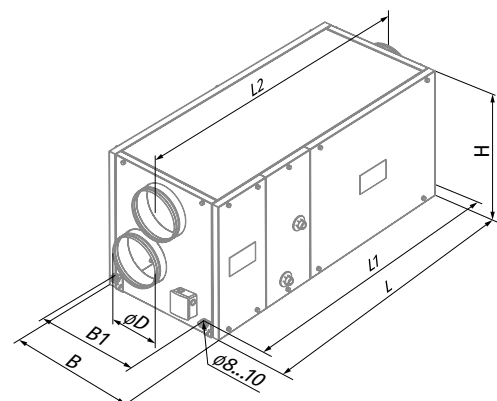

Technical data

Parameters	KOMFORT LW 800-4	KOMFORT LW 1100-4
Voltage [V / 50 Hz]	1 ~ 230	1 ~ 230
Number of water heater rows	4	4
Power [W]	490	820
Current [A]	2.16	3.6
Max. air flow [m³/h (l/s)]	780 (217)	1100 (306)
RPM [min ⁻¹]	1650	1850
Sound pressure level at 3 m distance [dBA]	48	60
Transported air temperature [°C]	-25...+40	-25...+40
Casing material	aluzinc	aluzinc
Insulation	50 mm mineral wool	50 mm mineral wool
Extract filter	G4	G4
Supply filter	G4	G4
Connected air duct diameter [mm]	250	250
Weight [kg]	88	88
Heat recovery efficiency [%]	up to 78	up to 78
Heat exchanger type	cross-flow	cross-flow
Heat exchanger material	polystyrene	polystyrene
ErP	2016	-

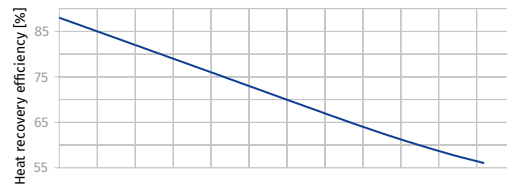
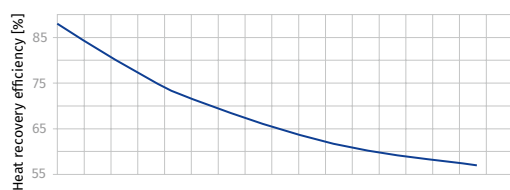
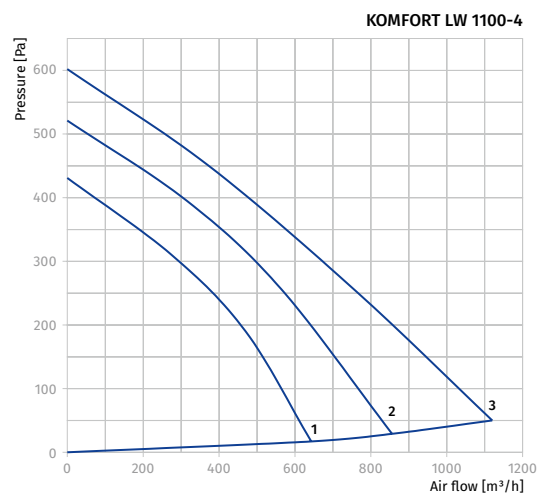
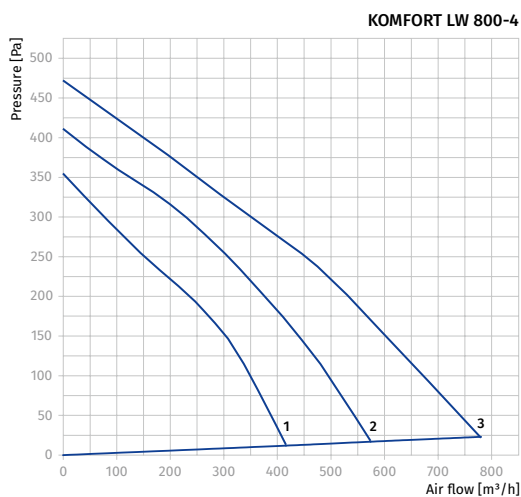

Parameters	KOMFORT LW 1700-4	KOMFORT LW 2100-4
Voltage [V / 50 Hz]	1 ~ 230	1 ~ 230
Number of water heater rows	4	4
Power [W]	980	1300
Current [A]	4.3	5.68
Max. air flow [m³/h (l/s)]	1700 (472)	2100 (583)
RPM [min ⁻¹]	1100	1150
Sound pressure level at 3 m distance [dBA]	49	65
Transported air temperature [°C]	-25...+40	-25...+40
Casing material	aluzinc	aluzinc
Insulation	50 mm mineral wool	50 mm mineral wool
Extract filter	G4	G4
Supply filter	G4	G4
Connected air duct diameter [mm]	315	315
Weight [kg]	99	99
Heat recovery efficiency [%]	up to 77	up to 77
Heat exchanger type	cross-flow	cross-flow
Heat exchanger material	polystyrene	polystyrene
ErP	-	-

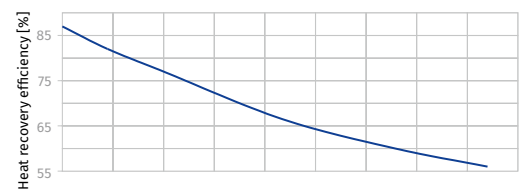
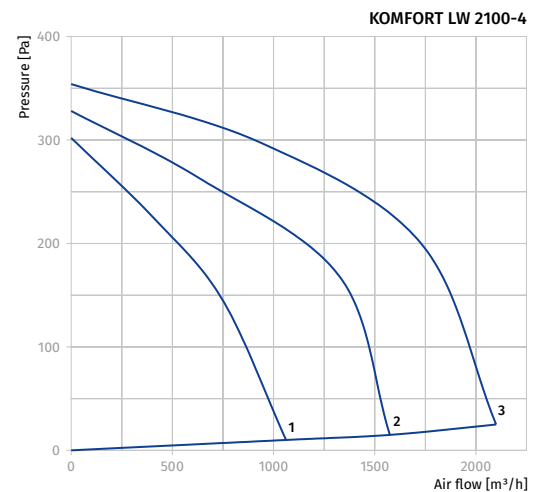
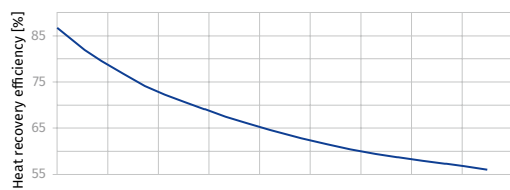
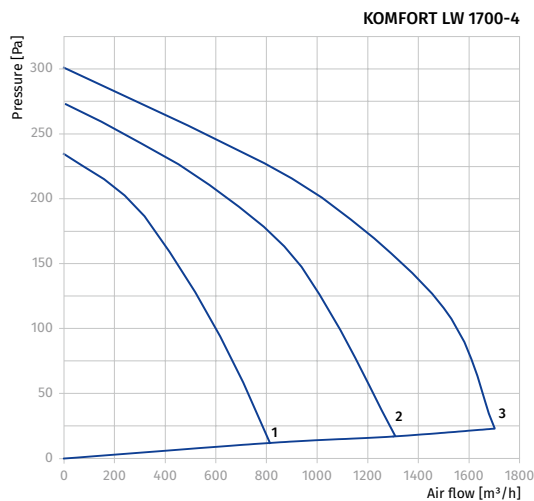

Hot water coil calculation diagram

KOMFORT LW 800-4

Air temperature downstream of the water heating coils [°C]

15 20 25 30 35 40 45 50 55 60 65

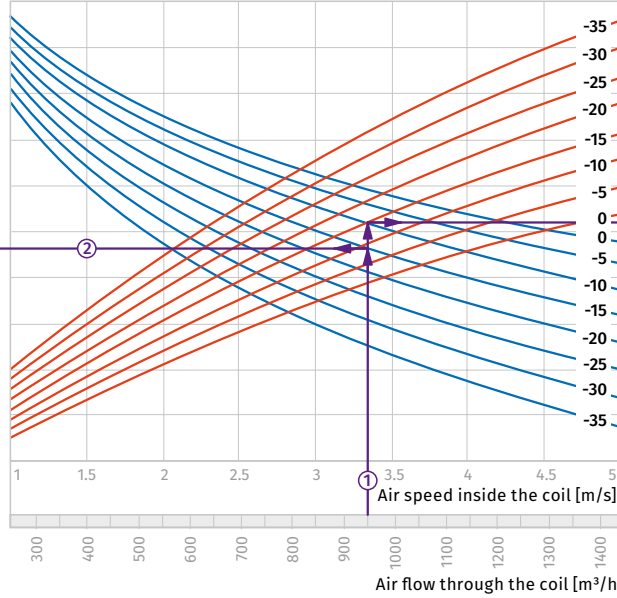
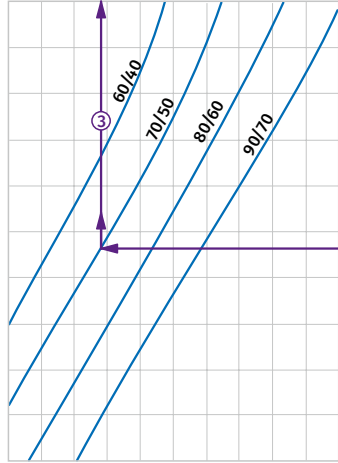

Coil heating capacity [kW]

4 8 12 16 20 24 28 32

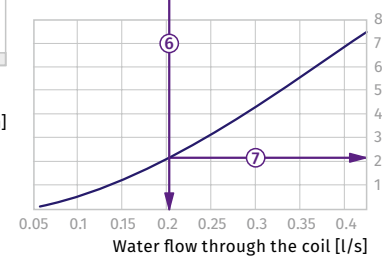
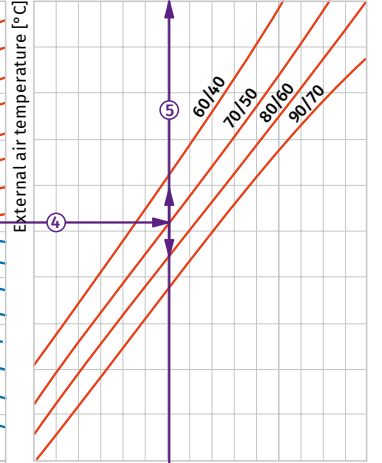

Water pressure drop [kPa]

How to use water heater diagrams.

The air flow is 950 m³/h and the air speed in the heater is 3.35 m/s ①.

- To calculate the maximum air temperature find the intersection point of the air flow line ① with the rated outer temperature shown in blue line (e.g., -15 °C) and draw the line ② to the left until it crosses the water in/out temperature curve (e.g., +70/+50). From this point draw a vertical line to the supply air temperature downstream of the heater (+29 °C) ③.

- To calculate the heater power find the intersection point of the air flow ① with the rated winter temperature shown in red line (e.g., -15 °C) and draw the line ④ to the right until it crosses the water in/out temperature curve (e.g., +70/+50). From this point draw a vertical line to the heater power axis (16.0 kW) ⑤.

- To calculate the required water flow in the heater prolong this line ⑥ downwards to the water flow axis (0.2 l/s).
- To calculate the water pressure drop in the heater find the intersection point of the line ⑥ with the pressure loss curve and prolong the line ⑦ to the right on the water pressure drop axis (2.1 kPa).

KOMFORT LW 1100-4

Air temperature downstream of the water heating coils [°C]

15 20 25 30 35 40 45 50 55 60 65

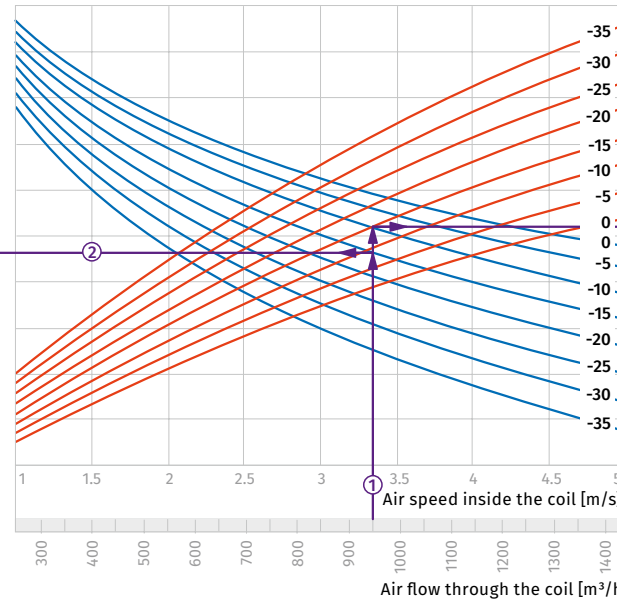
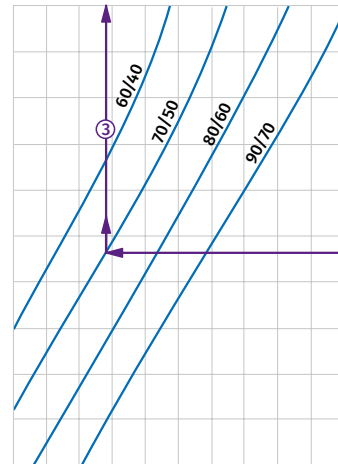

Coil heating capacity [kW]

4 8 12 16 20 24 28 32

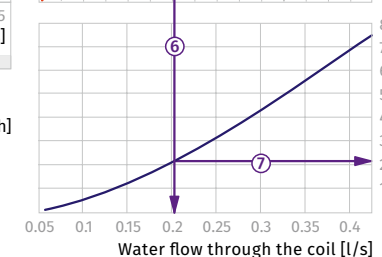
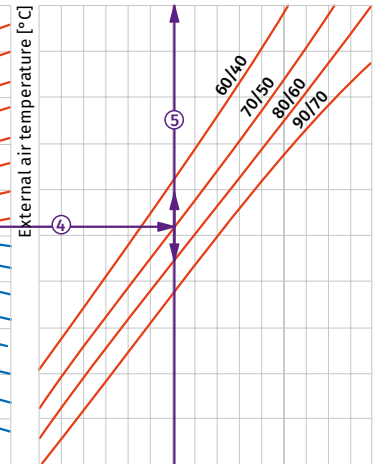

Water pressure drop [kPa]

How to use water heater diagrams.

The air flow is 950 m³/h and the air speed in the heater is 3.35 m/s ①.

- To calculate the maximum air temperature find the intersection point of the air flow line ① with the rated outer temperature shown in blue line (e.g., -15 °C) and draw the line ② to the left until it crosses the water in/out temperature curve (e.g., +70/+50). From this point draw a vertical line to the supply air temperature downstream of the heater (+29 °C) ③.

- To calculate the heater power find the intersection point of the air flow ① with the rated winter temperature shown in red line (e.g., -15 °C) and draw the line ④ to the right until it crosses the water in/out temperature curve (e.g., +70/+50). From this point draw a vertical line to the heater power axis (16.0 kW) ⑤.

- To calculate the required water flow in the heater prolong this line ⑥ downwards to the water flow axis (0.2 l/s).
- To calculate the water pressure drop in the heater find the intersection point of the line ⑥ with the pressure loss curve and prolong the line ⑦ to the right on the water pressure drop axis (2.1 kPa).

KOMFORT LW 1700-4

Air temperature downstream of the water heating coils [°C]

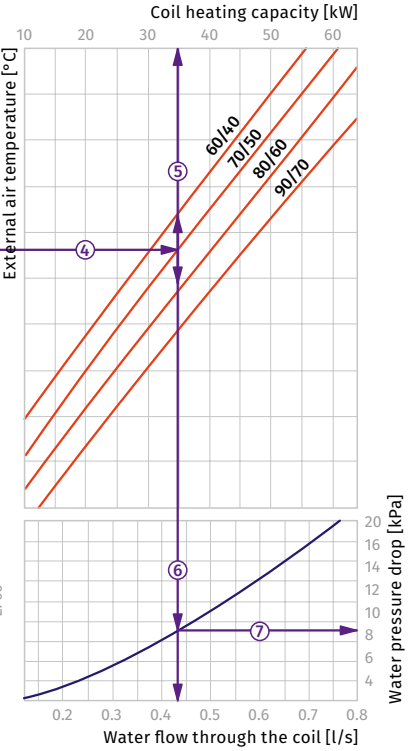
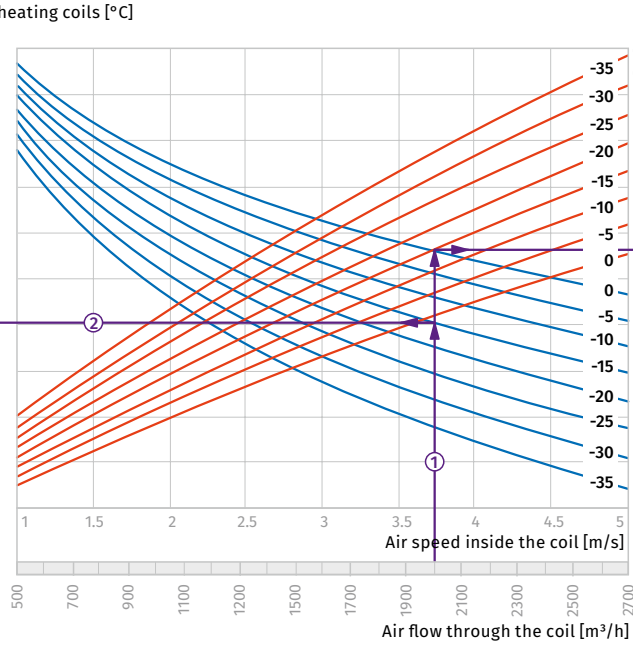
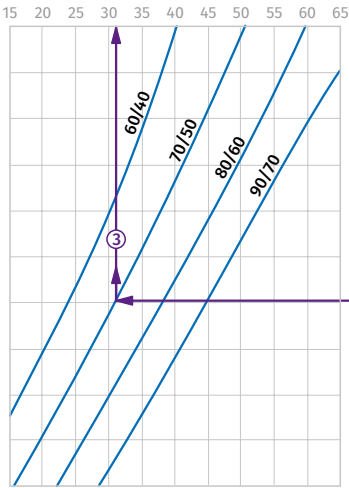

How to use water heater diagrams.

The air flow is 2000 m³/h and the air speed in the heater is 3.75 m/s ①.

- To calculate the maximum air temperature find the intersection point of the air flow line ① with the rated outer temperature shown in blue line (e.g., -15 °C) and draw the line ② to the left until it crosses the water in/out temperature curve (e.g., +70/+50). From this point draw a vertical line to the supply air temperature downstream of the heater (+31 °C) ③.

- To calculate the heater power find the intersection point of the air flow ① with the rated winter temperature shown in red line (e.g., -15 °C) and draw the line ④ to the right until it crosses the water in/out temperature curve (e.g., +70/+50). From this point draw a vertical line to the heater power axis (35.0 kW) ⑤.

- To calculate the required water flow in the heater prolong this line ⑥ downwards to the water flow axis (0.43 l/s).
- To calculate the water pressure drop in the heater find the intersection point of the line ⑥ with the pressure loss curve and prolong the line ⑦ to the right on the water pressure drop axis (9.0 kPa).

KOMFORT LW 2100-4

Air temperature downstream of the water heating coils [°C]

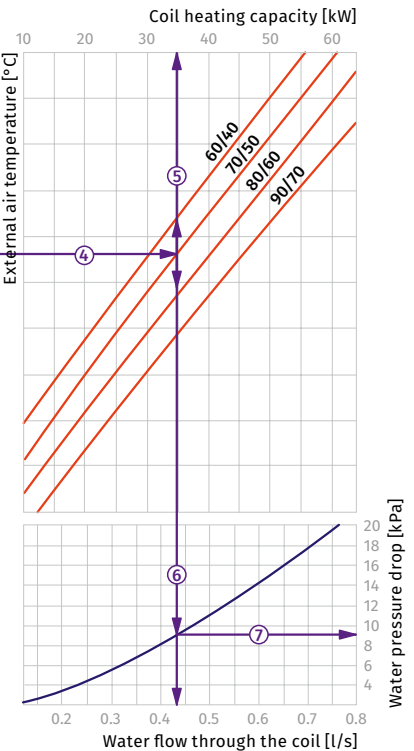
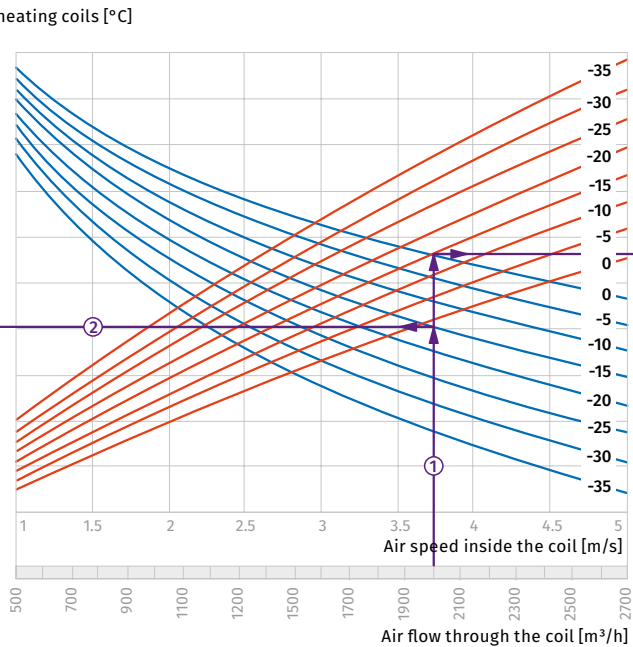
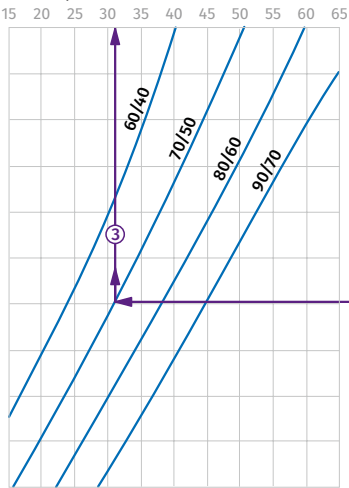

How to use water heater diagrams.

The air flow is 2000 m³/h and the air speed in the heater is 3.75 m/s ①.

- To calculate the maximum air temperature find the intersection point of the air flow line ① with the rated outer temperature shown in blue line (e.g., -15 °C) and draw the line ② to the left until it crosses the water in/out temperature curve (e.g., +70/+50). From this point draw a vertical line to the supply air temperature downstream of the heater (+31 °C) ③.

- To calculate the heater power find the intersection point of the air flow ① with the rated winter temperature shown in red line (e.g., -15 °C) and draw the line ④ to the right until it crosses the water in/out temperature curve (e.g., +70/+50). From this point draw a vertical line to the heater power axis (35.0 kW) ⑤.

- To calculate the required water flow in the heater prolong this line ⑥ downwards to the water flow axis (0.43 l/s).
- To calculate the water pressure drop in the heater find the intersection point of the line ⑥ with the pressure loss curve and prolong the line ⑦ to the right on the water pressure drop axis (9.0 kPa).

Accessories

		KOMFORT LW 800-4	KOMFORT LW 1100-4	KOMFORT LW 1700-4	KOMFORT LW 2100-4
G4 panel filter		FP 550x253x48 G4	FP 550x253x48 G4	FP 780x273x48 G4	FP 780x273x48 G4
Silencer		SD 250	SD 250	SD 315	SD 315
Silencer		SDF 250	SDF 250	SDF 315	SDF 315
Backdraft air damper		VRV 250	VRV 250	VRV 315	VRV 315
Air damper		VK 250	VK 250	VK 315	VK 315
Summer block		SB C4 300/384	SB C4 300/384	SB C4 300/300 (2 pcs.)	SB C4 300/300 (2 pcs.)

KOMFORT Roto EC S(E)

Heat recovery air handling units

Features

- Air handling units for efficient supply and exhaust ventilation in flats, houses, cottages and other buildings.
- Heat recovery is provided by the rotary heat exchanger and minimizes ventilation heat losses.
- Controllable air exchange for creating the best suitable indoor microclimate.
- Compatible with round Ø 125, 160 and 200 mm air ducts.
- Additional spigot for kitchen hood air duct connection.



Air flow:
up to 670 m³/h
186 l/s



Heat recovery efficiency:
up to 92 %



Design

- The fan casing is made of galvanized steel, internally filled with mineral wool layer for heat and sound insulation.
- The spigots are located at the top of the unit and are rubber sealed for airtight connection to the air ducts.
- The insulation of **KOMFORT Roto EC S2(E) 200** is 20 mm, for **KOMFORT Roto EC S(E) 280, 400** and **600** is 40 mm.
- **KOMFORT Roto EC S(2)**: model without electric heater.
- **KOMFORT Roto EC S(2)E**: model with electric heater.

Fans

- High-efficient external rotor EC motors and centrifugal impellers with forward curved blades are used for air supply and exhaust.

- EC motors have the best power consumption to air flow ratio and meet the latest demands concerning energy saving and high-efficient ventilation.
- EC motors are featured with high performance, low noise level and totally controllable speed range.
- Dynamically balanced impellers.

Kitchen hood

- All units are equipped with a 5th spigot for connection to the kitchen hood air duct.
- The distinctive feature of **KOMFORT Roto EC S2(E) 200** is the possibility to connect the kitchen hood DAH 251-13 (ordered separately) directly to the unit.



KOMFORT ROTO EC S2(E) 200

KOMFORT ROTO EC S2(E) 280

KOMFORT ROTO EC S(E) 400
KOMFORT ROTO EC S(E) 600

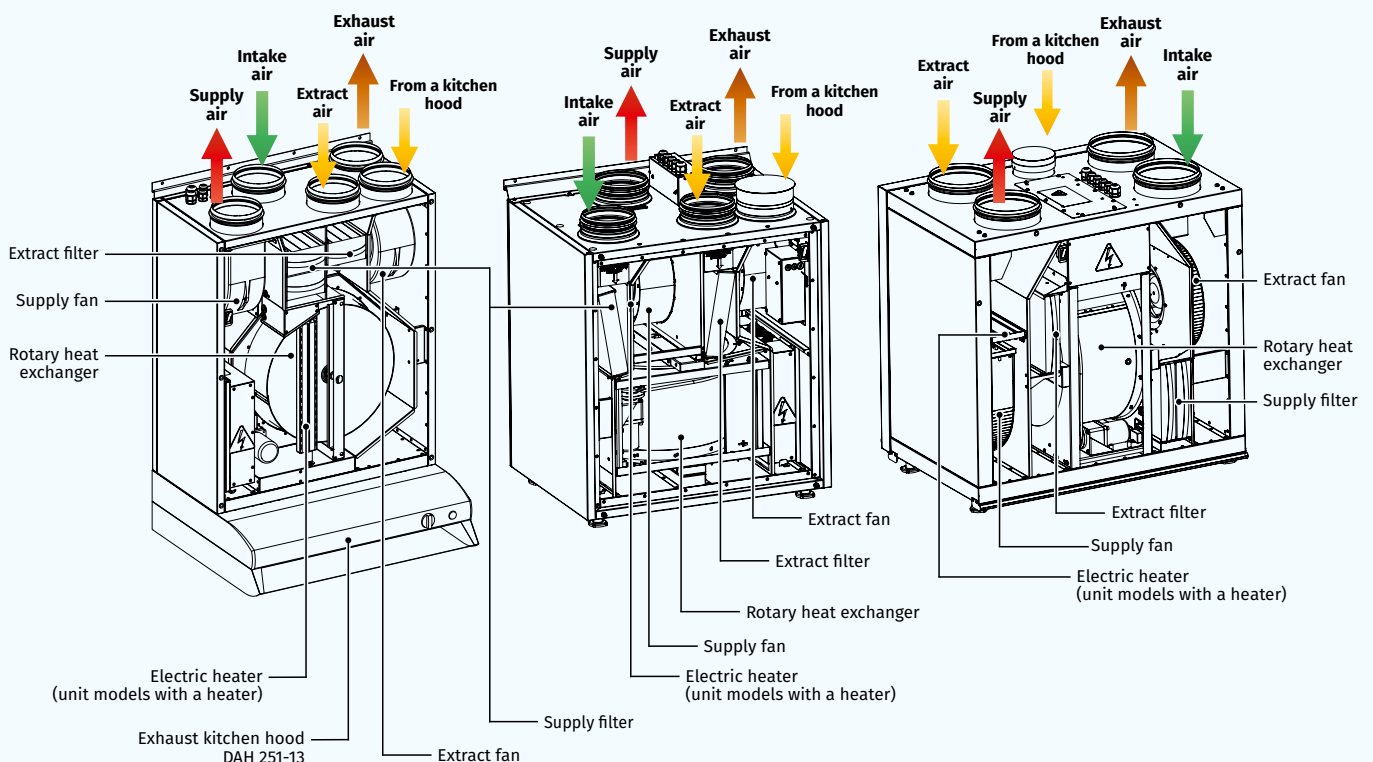

Air filtration

- Two built-in G4 and F7 filters provide efficient supply air filtration. The unit **KOMFORT ROTO EC S2(E) 280** features F7 filter.
- The G4 filter is used for extract air filtration.

Heat recovery

- The unit has a high-efficient rotary heat exchanger.
- The rotary regenerator is a short, rotating cylinder, filled with corrugated aluminium sheet layers. The air streams flow through them.
- The band layers of the heat regenerator first come in contact with the supply and then with extract air flows.
- Therefore the band is alternatively warmed up and cooled down and the extract air heat and humidity are transferred to the cold intake air. This way heat recovery reduces heat losses in the cold season and reduces operation load for air conditioner in the warm season.
- The advantages of the rotary regenerator as compared to the plate heat exchangers include no condensate generation, maintaining comfort air humidity and high freeze resistance.

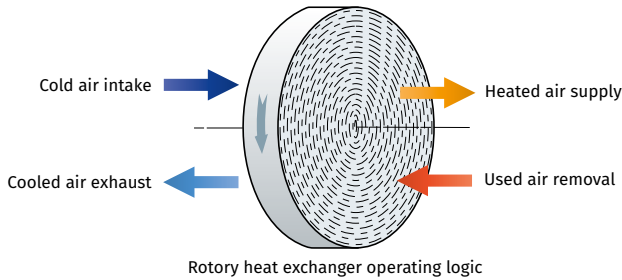

Heater

- The **KOMFORT Roto EC S(2)E** units are equipped with the electric heater. If the necessary temperature level of the supply air cannot be achieved through heat recovery, the heater turns on automatically and heats the air supplied to the premise. The heaters incorporate protective measures securing the safe unit operation.

Mounting

- The units can be fixed to the wall or mounted on the floor.
- During mounting stage the front and the back panels can be reversed providing either left-handed or right-handed unit mounting.

Control and automation

- KOMFORT Roto EC S... S21** units are equipped with an integrated automation system. The remote control panel is not included in the delivery set (purchased separately).
- The S21 controller allows integrating the unit into the **Smart Home** system or **BMS (Building Management System)**.
- The unit can be controlled via the **Blauberg AHU** mobile application via Wi-Fi.





Download the **Blauberg AHU** app for Android



Download the **Blauberg AHU** app for iOS



Automation functions

Functions	Description
Control via Wi-Fi using a mobile application	+
Control via a wired remote control panel	S22 control panel (option) 
Control via a wireless remote control panel	S22 Wi-Fi control panel (option) 
Control via a wired remote LCD control panel	S25 control panel (option) 
BMS (Building Management System)	RS-485
	Wi-Fi
	Ethernet
	MODBUS (RTU, TCP)
Blauberg Cloud Server service	+
Speed selection	+
Filter replacement indication	by filter timer
Alarm indication	full alarm description in the mobile application
Week-scheduled operation	+
Timer	+
Boost mode	+
Fireplace mode	+
Cooler connection	option
Kitchen hood connection	option
Minimum supply air temperature control	+
Humidity control	option
CO ₂ control	option
VOC control	option
PM2.5 control	option
Fire alarm sensor connection	option

Option: function is available when purchasing the appropriate accessory (see the "Accessories" section).

Designation key

Series	Unit type	Motor type	Spigot modification	Insulation	Heater type	Rated air flow [m³/h]	Control
KOMFORT	Roto: rotary heat exchanger	EC: electronically commutated motor	S: vertical spigot orientation	1: 40 mm 2: 20 mm	1: no heater E: electric heater	200; 280; 400; 600	S21

Overall dimensions [mm]

Model	∅ D	∅ D1	B	B1	H	H1	H2	L	L1
KOMFORT Roto EC S2(E) 200 S21	125	125	347	510	700	901	135	598	600
KOMFORT Roto EC S(E) 280 S21	125	125	482	-	630	754	-	598	-
KOMFORT Roto EC S(E) 400 S21	160	100	528	-	675	755	-	747	-
KOMFORT Roto EC S(E) 600 S21	200	125	628	-	772	852	-	819	-

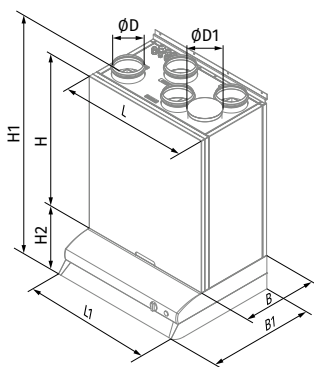

KOMFORT ROTO EC S2(E) 200
+ DAH 251-13

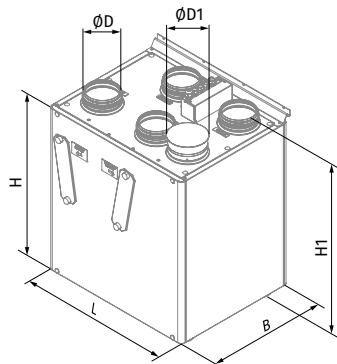

KOMFORT ROTO EC S(E) 280

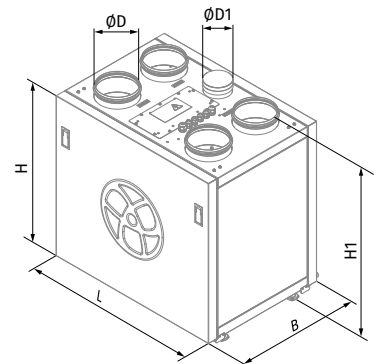

KOMFORT ROTO EC S(E) 400
KOMFORT ROTO EC S(E) 600

Technical data

Parameters	KOMFORT Roto EC S2 200 S21	KOMFORT Roto EC S2E 200 S21
Voltage [V / 50 (60) Hz]	1~230	1~230
Max. unit power without electric heater [W]	118	118
Max. power of electric heater [W]	-	700
Max. unit power [W]	118	818
Max. unit current without electric heater [A]	1.0	1.0
Max. unit current of electric heater [A]	-	3.0
Max. unit current [A]	1.0	4.0
Maximum air flow [m³/h (l/s)]	270 (75)	270 (75)
RPM [min⁻¹]	1800	1800
Sound pressure level at 3 m distance [dBA]	28	28
Operating temperature [°C]	-25...+40	-25...+40
Casing material	polymer coated steel	polymer coated steel
Insulation	20 mm mineral wool	20 mm mineral wool
Extract filter	G4	G4
Supply filter	G4+F7	G4+F7
Connected air duct diameter [mm]	125	125
Weight [kg]	47	48
Heat recovery efficiency [%] *	75-92	75-92
Heat exchanger type	rotary	rotary
Heat exchanger material	aluminum	aluminum
SEC class	A	A
ErP	2016, 2018	2016, 2018

*Heat recovery efficiency is specified in compliance with EN 13141-7.

KOMFORT ROTO EC S2(E) 200

Sound power level, A-weighted	Total	Octave frequency band [Hz]								LpA 3 m	LpA 1 m
		63	125	250	500	1000	2000	4000	8000		
LWA to supply inlet [dBA]	54	48	42	51	44	41	40	39	31		
LWA to supply outlet [dBA]	69	34	45	54	61	64	64	59	54		
LWA to exhaust inlet [dBA]	54	48	41	52	43	33	32	34	30		
LWA to exhaust outlet [dBA]	61	32	40	51	57	53	55	53	47		
LWA to environment [dBA]	49	25	41	43	43	39	38	35	24	28	38

Data provided for point 1 of the air flow diagram

Total power. Total sound pressure level.

Point	Total power of the unit [W]	Sound pressure level at 3 m (1 m) [dBA]
1	103	28 (38)
2	98	28 (38)
3	85	29 (39)
4	43	21 (31)
5	40	21 (31)
6	37	20 (30)
7	18	19 (29)
8	17	19 (29)
9	16	17 (27)

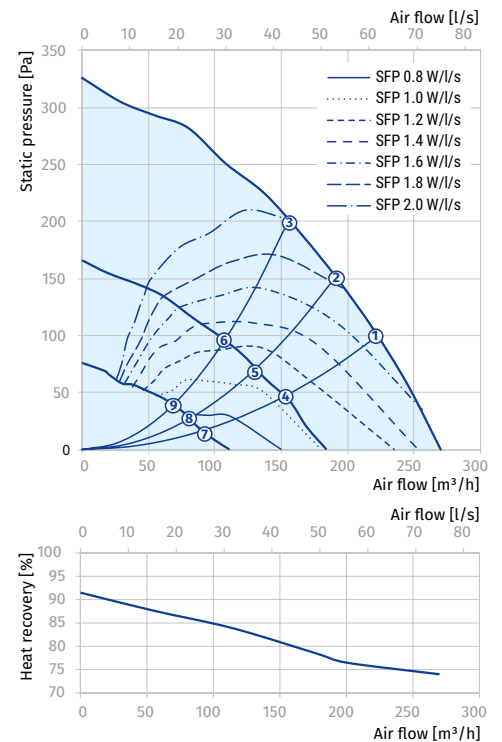

Calculation of air temperature downstream of the heat exchanger:

$$t = t_{\text{outd}} + k_{\text{hr}} \times (t_{\text{extr}} - t_{\text{outd}}) / 100,$$

where

t_{outd} – outdoor air temperature [°C]

t_{extr} – extract air temperature [°C]

k_{hr} – heat exchanger efficiency (according to the diagram) [%]

Parameters	KOMFORT Roto EC S 280 S21	KOMFORT Roto EC SE 280 S21
Voltage [V / 50 (60) Hz]	1~230	1~230
Max. unit power without electric heater [W]	195	195
Max. power of electric heater [W]	-	650
Max. unit power [W]	195	845
Max. unit current without electric heater [A]	1.9	1.9
Max. unit current of electric heater [A]	-	2.8
Max. unit current [A]	1.9	4.7
Maximum air flow [m³/h (l/s)]	300 (83)	300 (83)
RPM [min ⁻¹]	2050	2050
Sound pressure level at 3 m distance [dBA]	26	26
Operating temperature [°C]	-25...+40	-25...+40
Casing material	polymer coated steel	polymer coated steel
Insulation	40 mm mineral wool	40 mm mineral wool
Extract filter	G4	G4
Supply filter	F7	F7
Connected air duct diameter [mm]	125	125
Weight [kg]	63	64
Heat recovery efficiency [%] *	81-90	81-90
Heat exchanger type	rotary	rotary
Heat exchanger material	aluminum	aluminum
SEC class	A	A
ErP	2016, 2018	2016, 2018

*Heat recovery efficiency is specified in compliance with EN 13141-7.

KOMFORT ROTO EC S(E) 280

Sound power level, A-weighted	Total	Octave frequency band [Hz]								LpA 3 m	LpA 1 m
		63	125	250	500	1000	2000	4000	8000		
L _{WA} to supply inlet [dBA]	54	47	42	50	44	41	39	39	31		
L _{WA} to supply outlet [dBA]	69	63	56	65	59	55	50	52	46		
L _{WA} to exhaust inlet [dBA]	54	47	41	51	43	33	31	34	30		
L _{WA} to exhaust outlet [dBA]	65	61	50	61	55	46	43	46	40		
L _{WA} to environment [dBA]	47	42	37	43	36	31	28	26	21	26	36

Data provided for point 1 of the air flow diagram

Total power. Total sound pressure level.

Point	Total power of the unit [W]	Sound pressure level at 3 m (1 m) [dBA]
1	154	26 (36)
2	132	26 (36)
3	110	25 (35)
4	55	24 (34)
5	47	24 (34)
6	38	22 (32)
7	19	15 (25)
8	18	14 (24)
9	17	13 (23)

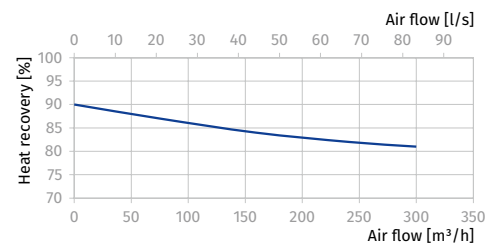
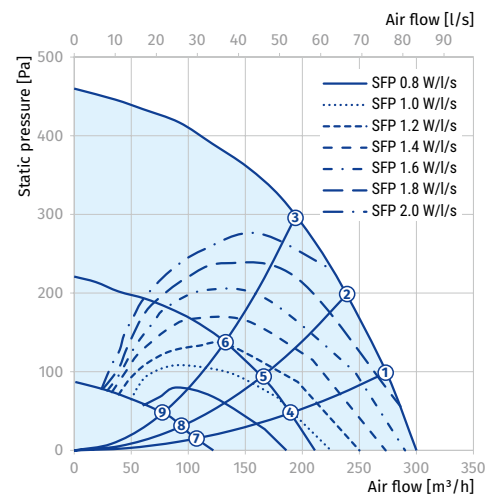

Parameters	KOMFORT Roto EC S 400 S21	KOMFORT Roto EC SE 400 S21
Voltage [V / 50 (60) Hz]	1~230	1~230
Max. unit power without electric heater [W]	200	200
Max. power of electric heater [W]	-	1400
Max. unit power [W]	200	1600
Max. unit current without electric heater [A]	1.4	1.4
Max. unit current of electric heater [A]	-	6.1
Max. unit current [A]	1.4	7.5
Maximum air flow [m³/h (l/s)]	440 (122)	440 (122)
RPM [min⁻¹]	3280	3280
Sound pressure level at 3 m distance [dBA]	33	33
Operating temperature [°C]	-25...+40	-25...+40
Casing material	polymer coated steel	polymer coated steel
Insulation	40 mm mineral wool	40 mm mineral wool
Extract filter	G4	G4
Supply filter	G4+F7	G4+F7
Connected air duct diameter [mm]	160	160
Weight [kg]	81	82
Heat recovery efficiency [%] *	76-85	76-85
Heat exchanger type	rotary	rotary
Heat exchanger material	aluminum	aluminum
SEC class	A	A
ErP	2016, 2018	2016, 2018

*Heat recovery efficiency is specified in compliance with EN 13141-7.

KOMFORT ROTO EC S(E) 400

Sound power level, A-weighted	Total	Octave frequency band [Hz]								LpA 3 m	LpA 1 m
		63	125	250	500	1000	2000	4000	8000		
LWA to supply inlet [dBA]	59	27	46	54	55	53	48	44	35		
LWA to supply outlet [dBA]	60	27	46	54	55	53	49	44	35		
LWA to exhaust inlet [dBA]	55	25	41	50	51	44	42	39	30		
LWA to exhaust outlet [dBA]	55	26	41	51	51	44	42	39	31		
LWA to environment [dBA]	54	18	36	47	49	48	43	37	33	33	43

Data provided for point 1 of the air flow diagram

Total power. Total sound pressure level.

Point	Total power of the unit [W]	Sound pressure level at 3 m (1 m) [dBA]
1	170	33 (43)
2	170	33 (43)
3	170	32 (42)
4	68	31 (41)
5	65	28 (38)
6	59	27 (37)
7	26	23 (33)
8	25	21 (31)
9	25	19 (29)

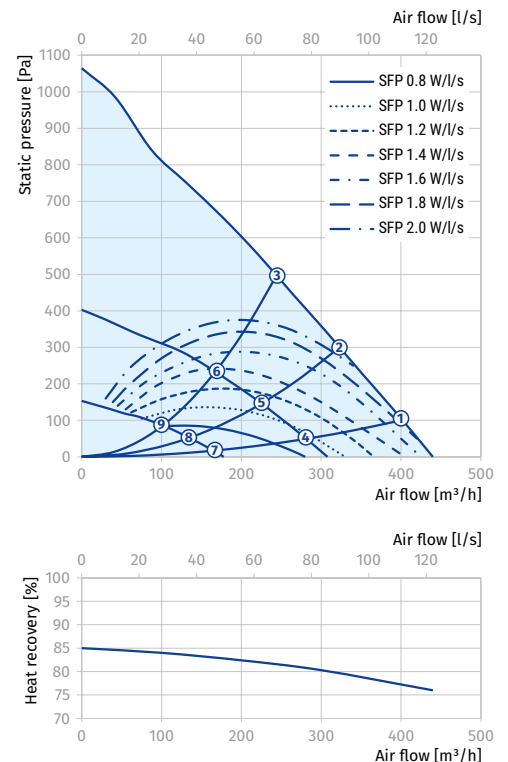

Parameters	KOMFORT Roto EC S 600 S21	KOMFORT Roto EC SE 600 S21
Voltage [V / 50 (60) Hz]	1~230	1~230
Max. unit power without electric heater [W]	405	405
Max. power of electric heater [W]	-	2800
Max. unit power [W]	405	3205
Max. unit current without electric heater [A]	2.6	2.6
Max. unit current of electric heater [A]	-	12.2
Max. unit current [A]	2.6	14.8
Maximum air flow [m ³ /h (l/s)]	670 (186)	670 (186)
RPM [min ⁻¹]	3230	3230
Sound pressure level at 3 m distance [dBA]	35	35
Operating temperature [°C]	-25...+40	-25...+40
Casing material	polymer coated steel	polymer coated steel
Insulation	40 mm mineral wool	40 mm mineral wool
Extract filter	G4	G4
Supply filter	G4+F7	G4+F7
Connected air duct diameter [mm]	200	200
Weight [kg]	90	92
Heat recovery efficiency [%] *	81-89	81-89
Heat exchanger type	rotary	rotary
Heat exchanger material	aluminum	aluminum
SEC class	A	A
ErP	2016, 2018	2016, 2018

*Heat recovery efficiency is specified in compliance with EN 13141-7.

KOMFORT ROTO EC S(E) 600

Sound power level, A-weighted	Total	Octave frequency band [Hz]								LpA 3 m	LpA 1 m
		63	125	250	500	1000	2000	4000	8000		
L _{WA} to supply inlet [dBA]	82	65	63	65	80	74	74	68	64		
L _{WA} to supply outlet [dBA]	66	60	56	55	63	58	49	40	33		
L _{WA} to exhaust inlet [dBA]	82	64	67	71	81	77	79	75	67		
L _{WA} to exhaust outlet [dBA]	70	51	64	62	68	60	60	50	42		
L _{WA} to environment [dBA]	56	39	47	46	54	46	46	44	40	35	45







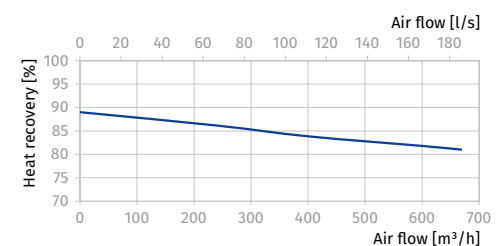
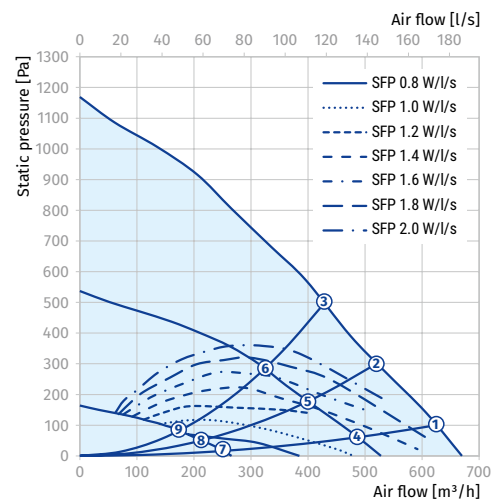











Data provided for point 1 of the air flow diagram



















Total power. Total sound pressure level.

Point	Total power of the unit [W]	Sound pressure level at 3 m (1 m) [dBA]
1	375	35 (45)
2	375	35 (45)
3	375	34 (44)
4	163	30 (40)
5	155	29 (39)
6	151	28 (38)
7	43	27 (37)
8	42	23 (33)
9	39	23 (33)



Accessories

		KOMFORT Roto EC S2(E) 200 S21	KOMFORT Roto EC S(E) 280 S21
G4 panel filter		FP 284x103x60 G4	FP 400x196x40 G4
F7 panel filter		FP 284x103x60 F7	FP 400x196x40 F7
Control panel		S22	S22
Wireless control panel		S22 Wi-Fi	S22 Wi-Fi
LCD control panel		S25	S25
VOC sensor		DPWQ30600	DPWQ30600
External CO ₂ sensor		DPWQ40200	DPWQ40200
CO ₂ sensor with indication		CD-1	CD-1
CO ₂ sensor		CD-2	CD-2
Humidity sensor		DPWC11200	DPWC11200
Humidity sensor		HR-S	HR-S
Humidity sensor		FS2	FS2
Kitchen hood		DAH 251-13	DAH 251-13
Silencer		SD 125	SD 125
Backdraft air damper		VRV 125	VRV 125
Air damper		VKA 125	VKA 125
Electric actuator		LF230	LF230
Electric actuator		TF230	TF230

		KOMFORT Roto EC S(E) 400 S21	KOMFORT Roto EC S(E) 600 S21
G4 panel filter		FP 436x196x40 G4	FP 536x220x40 G4
F7 panel filter		FP 436x196x40 F7	FP 536x220x40 F7
Control panel		S22	S22
Wireless control panel		S22 Wi-Fi	S22 Wi-Fi
LCD control panel		S25	S25
VOC sensor		DPWQ30600	DPWQ30600
External CO ₂ sensor		DPWQ40200	DPWQ40200
CO ₂ sensor with indication		CD-1	CD-1
CO ₂ sensor		CD-2	CD-2
Humidity sensor		DPWC11200	DPWC11200
Humidity sensor		HR-S	HR-S
Humidity sensor		FS2	FS2
Kitchen hood		DAH 251-13	DAH 251-13
Silencer		SD 160	SD 200
Backdraft air damper		VRV 160	VRV 200
Air damper		VKA 160	VKA 200
Electric actuator		LF230	LF230
Electric actuator		TF230	TF230

KOMFORT RoTo EC S6(E)K 200

Air handling units with rotary heat exchanger



Features

- Air handling units for efficient supply and exhaust ventilation in flats, houses, cottages and other buildings.
- Heat recovery is provided by the rotary heat exchanger and minimizes ventilation heat losses.
- Controllable air exchange for creating the best suitable indoor microclimate.
- Compatible with round Ø 125 mm air ducts.
- Additional spigot for kitchen hood air duct connection.



Air flow:
up to 270 m³/h
75 l/s



Heat recovery efficiency:
up to 92 %



Design

- The fan casing is made of galvanized steel, internally filled with mineral wool layer for heat and sound insulation.
- The spigots are located at the top of the unit and are rubber sealed for airtight connection to the air ducts.
- The insulation is 20 mm thick.
- **KOMFORT Roto EC S6K:** model without an electric heater.
- **KOMFORT Roto EC S6EK:** model with an electric heater.

- EC motors are featured with high performance, low noise level and totally controllable speed range.
- Dynamically balanced impellers.

Kitchen hood

- All units are equipped with a built-in kitchen hood.

Fans

- High-efficient external rotor EC motors and centrifugal impellers with forward curved blades are used for air supply and exhaust.
- EC motors have the best power consumption to air flow ratio and meet the latest demands concerning energy saving and high-efficient ventilation.

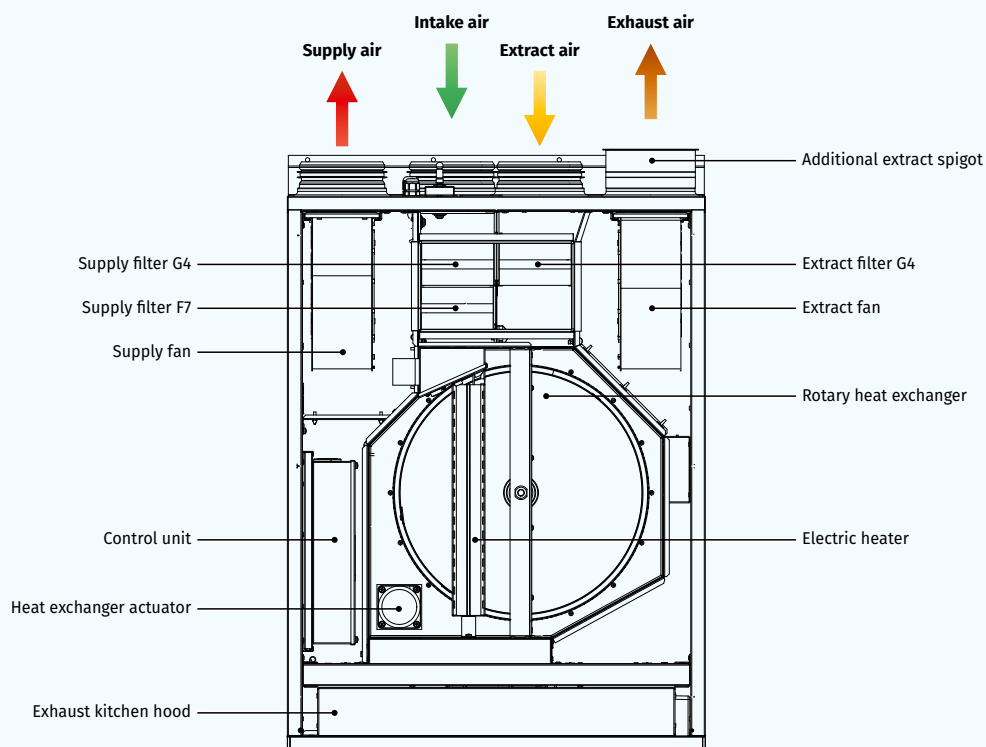

Air filtration

- Two built-in G4 and F7 filters provide efficient supply air filtration.
- The G4 filter is used for extract air filtration.

Heat recovery

- The unit has a high-efficient rotary heat exchanger (regenerator).
- The rotary heat exchanger is a short, rotating cylinder, filled with corrugated aluminium sheet layers. The air streams flow through them.
- The band layers of the heat exchanger first come in contact with the supply and then with extract air flows.
- Therefore the band is alternatively warmed up and cooled down and the extract air heat and humidity are transferred to the cold intake air. This way heat recovery reduces heat losses in the cold season and reduces operation load for air conditioner in the warm season.
- The advantages of the rotary heat exchanger as compared to plate heat exchangers include no condensate generation, maintaining comfort air humidity and high freeze resistance.

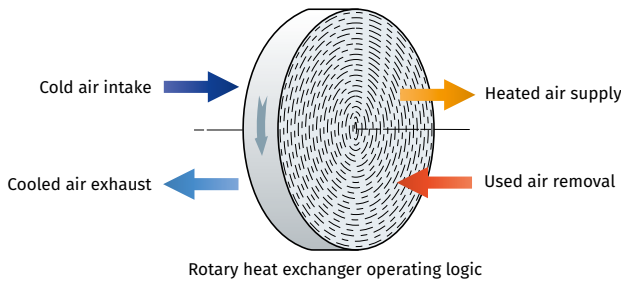

Heater

- The **KOMFORT Roto EC S6EK** units are equipped with an electric heater. If the necessary temperature level of the supply air cannot be achieved through heat recovery, the heater turns on automatically and heats the air supplied to the premise. The heaters incorporate protective measures securing the safe unit operation.

Mounting

- The unit can be fixed to the wall and embedded into the kitchen set.
- It is possible to attach decorative kitchen panels to the front panel of the unit.
- During mounting stage the front and the back panels can be reversed providing either left-handed or right-handed unit mounting.

Control and automation

- The units are equipped with an integrated automation system. The remote control panel is not included in the delivery set (purchased separately).
- The S21 controller allows integrating the unit into the **Smart Home** system or **BMS (Building Management System)**.
- The unit can be controlled via the **Blauberg AHU** mobile application via Wi-Fi.





Download the **Blauberg AHU** app for Android

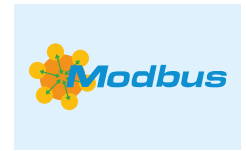

Download the **Blauberg AHU** app for iOS



Automation functions

Functions	Description
Control via Wi-Fi using a mobile application	+
Control via a wired remote control panel	S22 control panel (option) 
Control via a wireless remote control panel	S22 Wi-Fi control panel (option) 
Control via a wired remote LCD control panel	S25 control panel (option) 
BMS (Building Management System)	RS-485
	Wi-Fi
	Ethernet
	MODBUS (RTU, TCP)
Blauberg Cloud Server service	+
Speed selection	+
Filter replacement indication	by filter timer
Alarm indication	full alarm description in the mobile application
Week-scheduled operation	+
Timer	+
Boost mode	+
Fireplace mode	+
Cooler connection	option
Minimum supply air temperature control	+
Humidity control	option
CO ₂ control	option
VOC control	option
PM2.5 control	option
Fire alarm sensor connection	option

option: function is available when purchasing the appropriate accessory (see the "Accessories" section).

Designation key

Series	Unit type	Motor type	Spigot modification	Casing type	Additional components	Rated air flow [m ³ /h]	Control
KOMFORT	Roto: rotary regenerator	EC: electronically commutated motor	S: vertical spigot orientation	6: casing for a thin kitchen hood	_: no heater E: electric heater K: kitchen hood	200	S21

Overall dimensions [mm]

Model	∅ D	B	B1	H	H1	L
KOMFORT Roto EC S6(E)K 200 S21	125	348	371	791	865	598

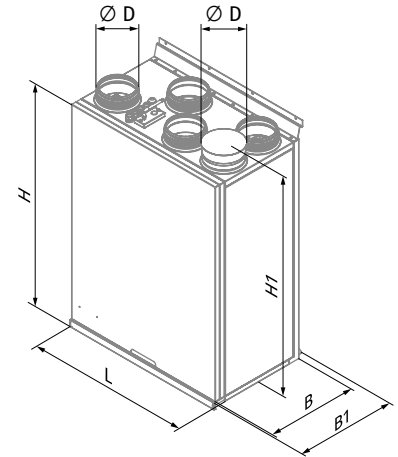

Technical data

Parameters	KOMFORT Roto EC S6K 200 S21	KOMFORT Roto EC S6EK 200 S21
Voltage [V / 50 (60) Hz]	1~230	1~230
Max. unit power without electric heater [W]	118	118
Max. power of electric heater [W]	-	700
Max. unit power [W]	118	818
Max. unit current without electric heater [A]	1.0	1.0
Max. unit current of electric heater [A]	-	3.0
Max. unit current [A]	1.0	4.0
Maximum air flow [m³/h (l/s)]	270 (75)	270 (75)
RPM [min⁻¹]	1800	1800
Sound pressure level at 3 m distance [dBA]	28	28
Operating temperature [°C]	-25...+40	-25...+40
Casing material	polymer coated steel	polymer coated steel
Insulation	20 mm mineral wool	20 mm mineral wool
Extract filter	G4	G4
Supply filter	G4+F7	G4+F7
Connected air duct diameter [mm]	125	125
Weight [kg]	47	48
Heat recovery efficiency [%] *	75-92	75-92
Heat exchanger type	rotary	rotary
Heat exchanger material	aluminum	aluminum
SEC class	A	A
ErP	2016, 2018	2016, 2018

* Heat recovery efficiency is specified in compliance with EN 13141-7.

KOMFORT ROTO EC S6(E)K 200

Sound power level, A-weighted	Total	Octave frequency band [Hz]								LpA 3 m	LpA 1 m
		63	125	250	500	1000	2000	4000	8000		
LWA to supply inlet [dBA]	54	48	42	51	44	41	40	39	31		
LWA to supply outlet [dBA]	69	34	45	54	61	64	64	59	54		
LWA to exhaust inlet [dBA]	54	48	41	52	43	33	32	34	30		
LWA to exhaust outlet [dBA]	61	32	40	51	57	53	55	53	47		
LWA to environment [dBA]	49	25	41	43	43	39	38	35	24	28	38

Data provided for point 1 of the air flow diagram

Total power. Total sound pressure level.

Point	Total power of the unit [W]	Sound pressure level at 3 m (1 m) [dBA]
1	103	28 (38)
2	98	28 (38)
3	85	29 (39)
4	43	21 (31)
5	40	21 (31)
6	37	20 (30)
7	18	19 (29)
8	17	19 (29)
9	16	17 (27)

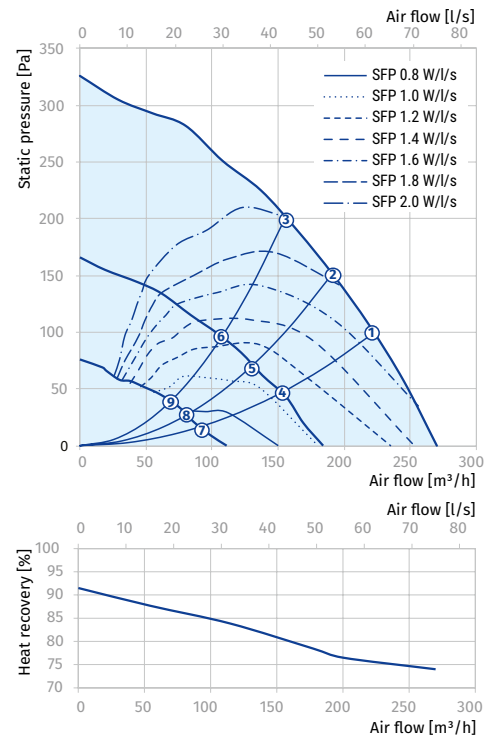

Calculation of air temperature downstream of the heat exchanger:

$$t = t_{\text{outd}} + k_{\text{hr}} \times (t_{\text{extr}} - t_{\text{outd}}) / 100,$$

















where

t_{outd} – outdoor air temperature [°C]

t_{extr} – extract air temperature [°C]

k_{hr} – heat exchanger efficiency (according to the diagram) [%]

Accessories

		KOMFORT Roto EC S6(E)K 200 S21
G4 panel filter		FP 284x103x60 G4
F7 panel filter		FP 284x103x60 F7
Control panel		S22
Wireless control panel		S22 Wi-Fi
LCD control panel		S25
Humidity sensor		FS2
Humidity sensor		HR-S
Humidity sensor		DPWC11200
CO ₂ sensor with indication		CD-1
CO ₂ sensor		CD-2
External CO ₂ sensor		DPWQ40200
VOC sensor		DPWQ30600
Silencer		SD 125
Backdraft air damper		VRV 125
Air damper		VKA 125
Electric actuator		LF230
Electric actuator		TF230

KOMFORT RoTo EC L(E)HP

Compact heat recovery air handling units

Features

- Air handling units for efficient supply and exhaust ventilation in flats, houses, cottages and other buildings.
- For arranging of controlled energy saving ventilation systems.
- Controllable air exchange for creating the best suitable indoor microclimate.
- A fully integrated heat pump eliminates the need for installing the indoor and outdoor units of an air conditioner inside the treated space and on the building face. The heated or cooled air is distributed via a duct system to individual rooms for air distribution through air diffusers which gives the building a clean aesthetic look both inside and outside.
- Compatible with round Ø 160 and 250 mm air ducts.



Air flow:
up to 955 m³/h
265 l/s



Heat recovery efficiency:
up to 85 %



Design

- The casing load-bearing structure consists of three-layer zinc aluminium panels with a 25 mm fibreglass interlayer for noise and heat insulation.
- The spigots are located at the sides of the unit and are equipped with rubber seals for airtight connection to the air ducts.
- Specially designed removable side panels provide easy access to all the internal components of the air handling unit and reduce maintenance space requirements.
- **KOMFORT Roto EC LHP:** models with a rotary regenerator and heat pump with no preheating
- **KOMFORT Roto EC LEHP:** models with a rotary regenerator, heat pump and a supply air preheater

Fans

- High-efficient external rotor EC motors and centrifugal impellers are used for air supply and exhaust.
- EC motors have the best power consumption to air flow ratio and meet the latest demands concerning energy saving and high-efficient ventilation.
- EC motors are featured with high performance, low noise level and totally controllable speed range.
- Dynamically balanced impellers.

Air filtration

- The built-in G4 supply filter and G4 extract filter provide air filtration.
- A F7 supply filter (specially ordered accessory) may be used for efficient supply air filtration.

AIR HANDLING UNITS WITH ROTARY HEAT EXCHANGER

KOMFORT ROTO EC L(E)HP 400

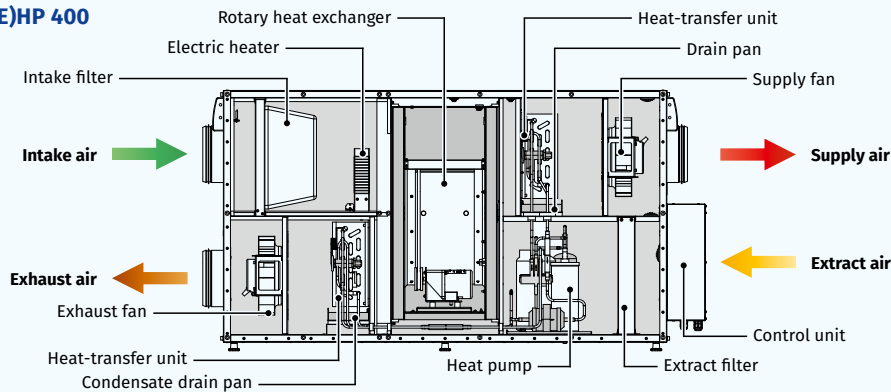

KOMFORT ROTO EC L(E)HP 700/900

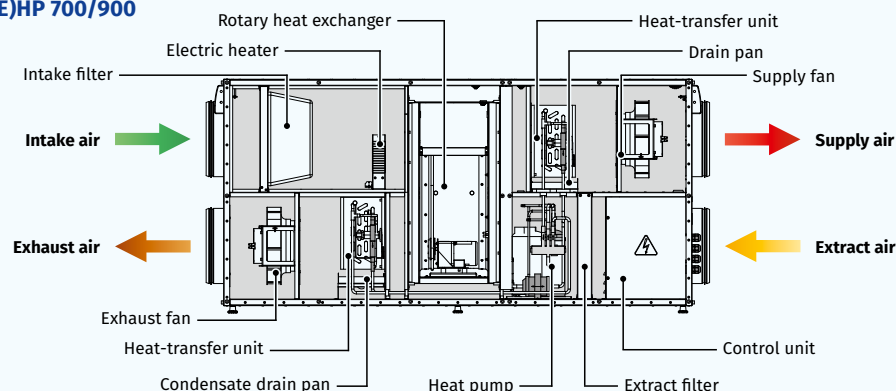

Two-stage heat energy recovery system

- o **Stage I** – heat energy recovery in the rotary heat exchanger.
- o **Stage II** – booster heating/booster cooling in the heat pump.

Heat recovery

- o The unit has a high-efficient rotary aluminium heat exchanger.
- o The rotary regenerator is a short, rotating cylinder, filled with corrugated aluminium sheet layers. The air streams flow through them.
- o The band layers of the heat regenerator first come in contact with the supply and then with extract air flows.
- o Therefore the band is alternatively warmed up and cooled down and the extract air heat and humidity are transferred to the cold intake air. This way heat recovery reduces heat losses in the cold season and reduces operation load for air conditioner in the warm season.
- o The advantages of the rotary regenerator as compared to the plate heat exchangers include no condensate generation, maintaining comfort air humidity and high freeze resistance.

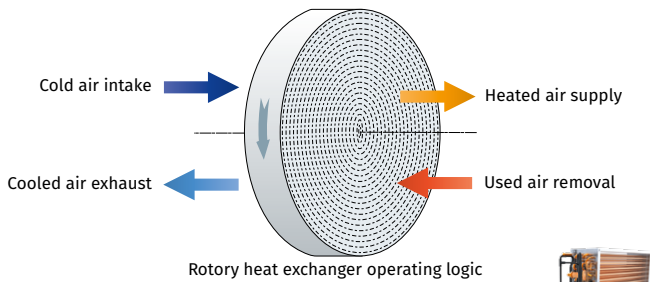

Heat pump

- o The air handling unit features a reversible heat pump which can warm up or cool down the supply air stream using the extract air heat. A fully integrated heat pump eliminates the need for installing the indoor and outdoor units of an air conditioner inside the treated space and on the building face. The heated or cooled air is distributed via a duct system to individual rooms for air distribution through air diffusers which gives the building a clean aesthetic look both inside and outside.
- o This device transfers the extract air heat energy to the supply air stream. The amount of heat transferred is 2–6 times larger than the amount of electric energy used to power the process.
- o The heat pump is equipped with an array of protection systems including low and high pressure protection, freeze protection (automatic defrosting) and compressor overheating protection.
- o The heat pump utilizes a high-efficiency rotary compressor which generates minimum noise. Ozone-layer friendly R410A cooling agent is used as the heat pump working fluid.

Air heater

- o The **KOMFORT Roto EC LEHP** unit is equipped with the optional posistor electric heater to warm up outdoor supply air at low temperatures.
- o Pre-heating reduces the number of heat pump defrosting cycles thus increasing the overall operational efficiency of the air handling unit.
- o The heater is divided into two active elements for reduced power electric power consumption while retaining sufficient heating capacity.

Control and automation

- o The **KOMFORT Roto EC L(E)HP S17** units are equipped with the thTune control panel with an LCD display.
- o The **KOMFORT Roto EC L(E)HP S18** units are equipped with the pGD1 control panel with an LCD display.



Unit operation modes

- o **"Auto" mode:** The unit runs in the automatic supply and exhaust mode maintaining a user-defined room temperature.
- o **"Heating" mode:** The unit ensures supply and exhaust ventilation of the treated space maintaining the room temperature above a pre-set threshold. As soon as the room temperature drops below the pre-set threshold the heat exchanger and the heat pump are engaged (in the heating mode).

- o **"Cooling" mode:** The unit ensures supply and exhaust ventilation of the treated space maintaining the room temperature below a pre-set threshold. As soon the room temperature exceeds the pre-set threshold the heat exchanger and the heat pump are engaged (in the cooling mode).
- o **"Heat Recovery" mode:** The unit runs in the supply and exhaust mode maintaining the room temperature by means of the heat exchanger only without engaging the heat pump. This mode is enabled automatically while in the "Auto", "Heating" or "Cooling" mode if the heat exchanger alone is able to maintain the user-defined room temperature without engaging the heat pump. This mode can also be enabled manually via the unit controller menu or the S18 (pGD1) control panel.
- o **"Ventilation" mode:** The unit ensures supply and exhaust ventilation of the treated space without maintaining a pre-set room temperature level. The heat exchanger and heat pump are disabled. Room temperature adjustment is not available. This operation mode is only available via the S18 (pGD1) control panel.
- o **"Defrosting" mode:** Enabled automatically (on elapsing of a pre-set time interval and/or on reaching a temperature threshold) while in the "Auto" and "Heating" modes to prevent the heat pump heat exchanger freezing. While in the "Defrosting" mode the fans are disabled. Upon the "Defrosting" mode deactivation the unit reverts to the previous operation mode automatically. While in the "Defrosting" mode user-selectable operation modes are not available.
- o **"Pre-Heating" mode:** While in the "Auto" or "Heating" modes at low ambient temperatures the supply air fed into the unit is warmed up by the electric pre-heater. This mode is enabled automatically upon the ambient temperature dropping below 8 °C. If the outdoor air temperature reaches above 8 °C the "Pre-Heating" mode is disabled. This mode is only available in factory configurations of the **KOMFORT Roto EC LEHP** models equipped with an electric heater. The "Pre-Heating" mode implementation in a **KOMFORT Roto EC LHP** requires upgrading the unit with a production electric heater (purchased separately) installed into the unit casing. The heater may only be installed by a service provider certified by the unit manufacturer.
- o **"Recirculation" mode:** This optional mode requires upgrading the unit with an external recirculation valve (purchased separately). The recirculation mode is enabled automatically at subzero ambient temperatures allowing a considerable reduction of unit energy consumption due to a partial redirection of the extract air into the supply duct of the unit.

Intelligent unit control system

- o **Limit Function:** Reduces air flow automatically to maintain a user-defined temperature. If the unit cannot execute the user-defined room temperature setting after running in the "Auto" or "Heating" mode for 20 minutes the air flow rate (fan speed) is reduced automatically. The unit reverts to the original fan operation mode upon reaching the target air temperature as defined by the user. While in the "Limit Function" mode the air flow adjustment is not available.
- o **Warming-up:** Blocks cold air supply into the premises in the "Auto" or "Heating" mode. The effect is achieved by warming up the heat pump heat exchanger in the supply air duct while the supply fan remains disabled. The "Warming-up" mode is enabled after the "Defrosting" mode as well as upon the first start if the outdoor air temperature is below +10 °C. Upon completion of the "Warming-up" cycle the unit reverts to the original "Auto" or "Heating" mode.
- o **Higher Speed:** Increases air flow capacity automatically while in the "Cooling" mode to prevent excessive pressure build-up in the heat pump. The exhaust fan reverts to the initial speed once the pressure has dropped to normal.
- o **Smart Safe:** Automatically protects the unit from operating outside the safe performance range. The unit is equipped with an intelligent hardware protection system ensuring its safe and reliable performance within the permissible range of ambient temperature conditions. Therefore, the unit is able to adjust operating parameters or disable certain units and assemblies to compensate for abnormal operating conditions in order to prevent equipment failure.
- o **Heat Pump Protection:** Automatically prevents heat pump failure:
 - Protects against abnormally high or low pressure build-up. If the coolant pressure reaches beyond the safe performance range the pressure sensors send signals to the unit controller to power off the heat pump compressor. The compressor power is restored once the pressure has reverted to normal
 - Compressor thermal protection against overheating. The compressor is powered off when its casing temperature becomes abnormally high. The power is restored once the casing temperature has dropped to the normal performance range
 - Delayed Start. Protects the compressor from cycling (by blocking too frequent activation/deactivation of the compressor)

- Serviceability:** The design solutions provide for easy access to the unit parts and components, facilitate its maintenance and replacement of the consumables and wear parts and ensure high serviceability of the entire air handling unit.
- Fresh Air:** Ensures clean air supply into the treated spaces. The unit is equipped with a G4 filter (F7 filter optional). The control system monitors the filter performance automatically and generates replacement signals as necessary.
- Ozone Protection:** The heat pump utilizes the R410A high-tech two-component cooling agent which does not deplete the ozone layer.
- Save Energy:** A comprehensive engineering and technical approach to reducing the unit energy consumption which comprises the following elements:
 - Posistor electric pre-heater with two active elements
 - Upgraded thermal insulation of the supply chamber
 - Integral high-performance air-to-air heat pump
 - Adjustable fan speed
 - Automatic heat exchanger and heat pump activation/ deactivation
 - Electric heater deactivation in the "Defrosting" mode
 - Intelligent Blauberg Software – air handling unit control suite for maintaining optimum performance characteristics at low energy consumption based on the exclusive control algorithms
- Low Noise:** A comprehensive engineering and technical approach to reducing the unit noise levels during operation comprising the following elements:
 - Heat pump integrated into the sound-proof unit casing
 - Adjustable-speed fans
 - Low-noise rotary compressor

- Autorestart:** The unit memorizes the current operation mode and restores it after a power outage.
- Simple Use:** The units are pre-assembled at the factory and are ready for operation. The installation and maintenance costs are reduced to a bare minimum. The unit operation does not require any special training due to a clean-cut user-friendly interface.
- CO₂ Control:** Maintains the CO₂ level in the treated space below a user-defined value. If the CO₂ level in the indoor space exceeds the pre-set value the air handling unit increases the air exchange rate automatically. This option is only available with the external CO₂ control sensor with a 0–10 V output signal (purchased separately).
- RH Control:** Maintains the relative humidity level in the treated space below a user-defined value. Should the relative humidity become abnormally high the unit increases the air exchange rate automatically. This option is only available with the S17 (th-Tune) control panel in a special configuration or the external relative humidity control sensor with a 0–10 V output signal (purchased separately).
- Rapid Access to Set Mode:** The larger the difference between the outdoor temperature and the pre-set indoor temperature, the faster the heat pump is activated.

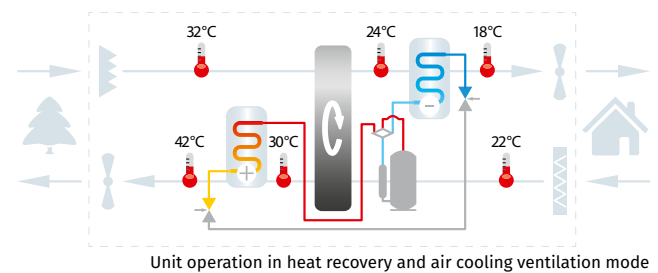
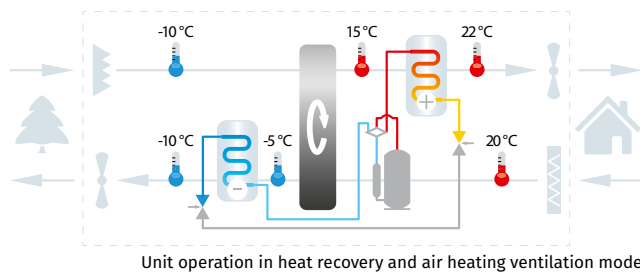

Designation key

Series	Unit type	Motor type	Spigot modification	Heater type	Modification	Rated air flow [m ³ /h]	Control
KOMFORT	Roto: rotary heat exchanger	EC: electronically commutated motor	L: horizontal spigot orientation	-: without heater E: electric heater	HP: heat pump	400; 700; 900	S17: thTune control panel S18: pGD1 control panel

Overall dimensions [mm]

Model	D	B	H	L	L1
KOMFORT Roto EC L(E)HP 400	159	648	710	1250	1421
KOMFORT Roto EC L(E)HP 700	249	748	750	1667	-
KOMFORT Roto EC L(E)HP 900	249	748	750	1667	-

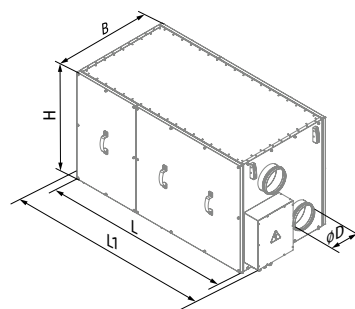

KOMFORT Roto EC L(E)HP 400

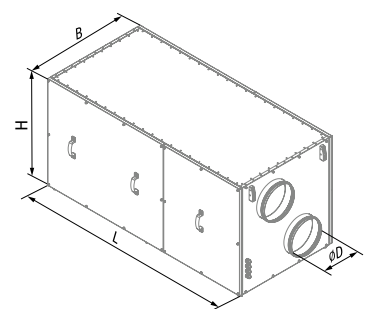

KOMFORT Roto EC L(E)HP 700
KOMFORT Roto EC L(E)HP 900

Technical data

Total parameters	KOMFORT Roto EC LHP 400 S17/S18	KOMFORT Roto EC LHP 700 S17/S18	KOMFORT Roto EC LHP 900 S17/S18	KOMFORT Roto EC LEHP 400 S17/S18	KOMFORT Roto EC LEHP 700 S17/S18	KOMFORT Roto EC LEHP 900 S17/S18
Maximum air flow [m³/h (l/s)]	520 (53)	830 (231)	955 (265)	520 (53)	830 (231)	955 (265)
Maximum transported air temperature [°C]	-10...+40	-10...+40	-10...+40	-25...+40	-25...+40	-25...+40
Heat recovery efficiency [%]	up to 85	up to 85	up to 85	up to 85	up to 85	up to 85
Sound pressure at 3 m [dBA]	45	52	58	45	52	58
Casing material	aluzinc	aluzinc	aluzinc	aluzinc	aluzinc	aluzinc
Weight [kg]	150	160	165	150	160	165
Connected air duct diameter [mm]	160	250	250	160	250	250
Heat exchanger type	rotary	rotary	rotary	rotary	rotary	rotary
Heat exchanger material	aluminium	aluminium	aluminium	aluminium	aluminium	aluminium
Air exhaust filter	G4	G4	G4	G4	G4	G4
Air supply filter	G4 (option: F7)	G4 (option: F7)	G4 (option: F7)	G4 (option: F7)	G4 (option: F7)	G4 (option: F7)

Electrical parameters						
Air-handling unit supply voltage [V / 50 Hz]	1 ~ 230	1 ~ 230	1 ~ 230	1 ~ 230	1 ~ 230	1 ~ 230
Maximum power consumption in "Heat Recovery" mode [kW]	0.31	0.36	0.46	0.31	0.36	0.46
Maximum power consumption in "Heat Recovery + Heat Pump" mode [kW]	0.745	0.94	1.195	0.745	0.94	1.195
Maximum power consumption in "Heat Recovery + Heat Pump + Pre-Heating" mode [kW]	-	-	-	2.145	3.74	3.995
Maximum current consumption [A]	4.6	5.7	6.7	10.9	18.5	19.4
Air-handling unit energy efficiency "Heating" mode (COP)	6	6.5	6.5	6	6.5	6.5
Air-handling unit energy efficiency "Cooling" mode (ERR)	4	4.15	4.25	4	4.15	4.25

Heat pump characteristics						
Coolant	R410A	R410A	R410A	R410A	R410A	R410A
Coolant weight [kg]	0.8	1.6	2	0.8	1.6	2
Heat output in "Heating" mode [W] at $t_o = +7\text{ °C}$; $t_k = +45\text{ °C}^*$	1560	2600	3250	1560	2600	3250
Heat output in "Cooling" mode [W] at $t_o = +7\text{ °C}$; $t_k = +45\text{ °C}^*$	1200	2000	2500	1200	2000	2500
Compressor type	Sealed, rotary type	Sealed, rotary type	Sealed, rotary type	Sealed, rotary type	Sealed, rotary type	Sealed, rotary type
Temperature setting range in "Cooling/Heating" modes [°C]	+16...+30	+16...+30	+16...+30	+16...+30	+16...+30	+16...+30

* t_o – coolant boiling temperature; t_k – coolant condensation temperature.

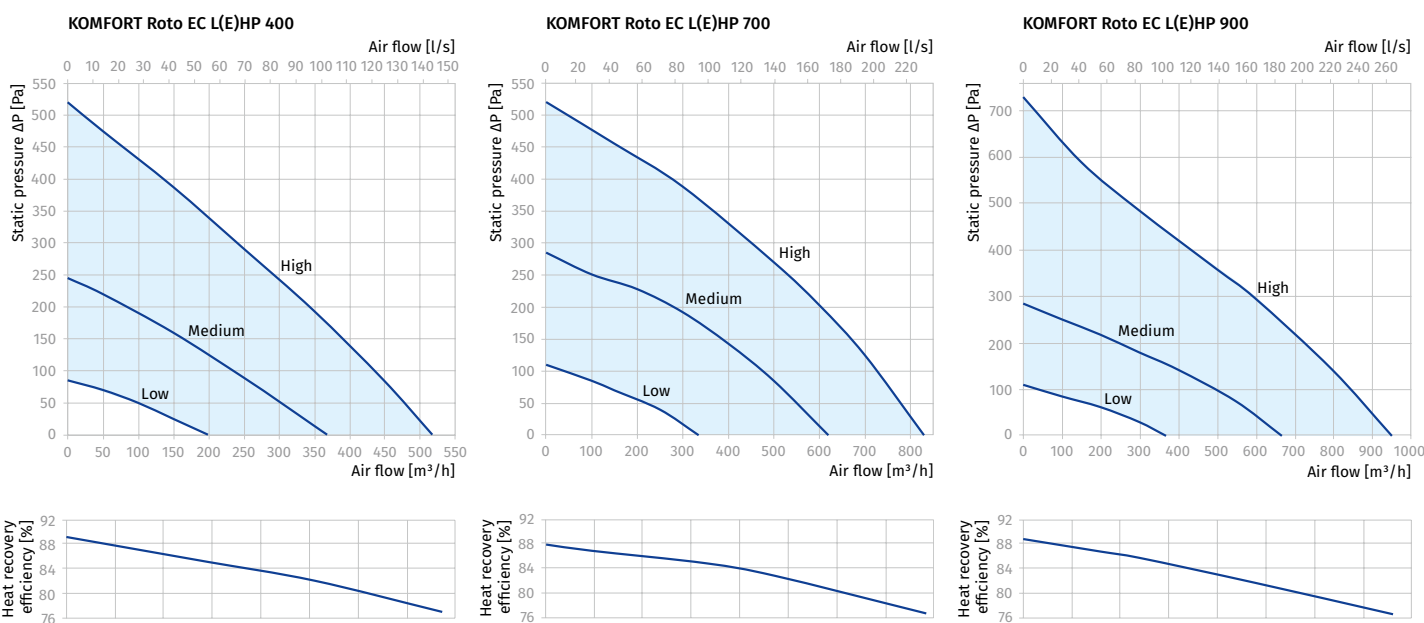

Heat pump characteristics in the "HEATING" mode

KOMFORT ROTO EC L(E)HP 400

Speed	Air flow rate		Room air temperature [°C]		Temperature at fresh air intake [°C]		Temperature of outdoor air supplied to treated space [°C]		Electric power consumption [kW]	COP* ₁ [W/W]	COP* ₂ [BTU/W]	Q _{heat,1} [kW]
	% of max	[m³/h]	Dry-bulb temperature	Wet-bulb temperature (relative humidity)	Dry-bulb temperature	Wet-bulb temperature (relative humidity)	Dry-bulb temperature	Wet-bulb temperature (relative humidity)				
High	100	400	20	12 (~38 %)	7	6 (~86 %)	26	14 (~25 %)	0.585	4.3	14.8	2.53
Medium	70	280	20	12 (~38 %)	7	6 (~86 %)	28	15 (~23 %)	0.485	4	13.8	1.96
Low	40	160	20	12 (~38 %)	7	6 (~86 %)	35	17 (~14 %)	0.475	3.1	10.7	1.49
High	100	400	20	12 (~38 %)	2	1 (~80 %)	25	12 (~18 %)	0.580	5.3	18	3.07
Medium	70	280	20	12 (~38 %)	2	1 (~80 %)	27	13 (~17 %)	0.475	4.9	16.8	2.33
Low	40	160	20	12 (~38 %)	2	1 (~80 %)	34	16 (~12.5 %)	0.465	3.7	12.5	1.71
High	100	400	20	12 (~38 %)	-7	-8 (~70 %)	21	8 (~8 %)	0.560	7.1	24.4	4
Medium	70	280	20	12 (~38 %)	-7	-8 (~70 %)	22	9 (~8 %)	0.450	6.4	21.9	2.89
Low	40	160	20	12 (~38 %)	-7	-8 (~70 %)	25	10 (~8 %)	0.440	4.1	14.1	1.81

*Important! The temperature parameters and the COP and ERR factors were defined at the temperature-humidity conditions as per the EN 13141 -7:2010 standard. The factors were calculated based on the assumption of continuous heat pump operation whereas the cyclic heat pump operation was disregarded.

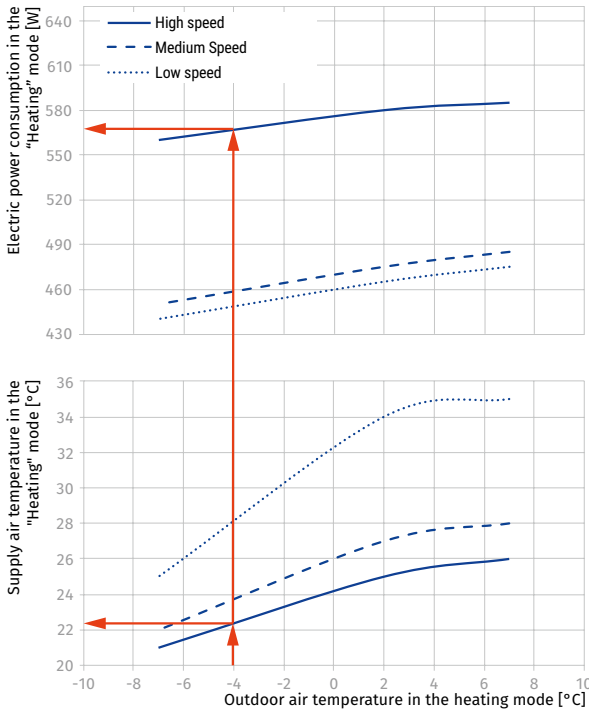

AIR HANDLING UNITS WITH ROTARY HEAT EXCHANGER

Heat pump characteristics in the "COOLING" mode

KOMFORT ROTO EC L(E)HP 400

Speed	Air flow rate		Room air temperature [°C]		Temperature at fresh air intake [°C]		Temperature of outdoor air supplied to treated space [°C]		Electric power consumption [kW]	COP*, [W/W]	COP*, [BTU/W]	Q _{cool} [kW]
	% of max	[m³/h]	Dry-bulb temperature	Wet-bulb temperature (relative humidity)	Dry-bulb temperature	Wet-bulb temperature (relative humidity)	Dry-bulb temperature	Wet-bulb temperature (relative humidity)				
High	100	400	27	19 (~47.5 %)	35	24 (~40 %)	23	21 (~85 %)	0.664	2.4	8.2	1.6
Medium	70	280	27	19 (~47.5 %)	35	24 (~40 %)	22	20.5 (~85 %)	0.560	2.2	7.4	1.21
Low	40	160	27	19 (~47.5 %)	35	24 (~40 %)	20	19 (~90 %)	0.554	1.8	6.2	1.01
High	100	400	27	19 (~47.5 %)	27	19 (~47.5 %)	19	16.5 (~78 %)	0.619	1.7	5.9	1.07
Medium	70	280	27	19 (~47.5 %)	27	19 (~47.5 %)	18	15.5 (~78 %)	0.522	1.6	5.5	0.84
Low	40	160	27	19 (~47.5 %)	27	19 (~47.5 %)	15	14 (~88 %)	0.495	1.6	5.5	0.8

*Important! The temperature parameters and the COP and ERR factors were defined at the temperature-humidity conditions as per the EN 13141 -7:2010 standard. The factors were calculated based on the assumption of continuous heat pump operation whereas the cyclic heat pump operation was disregarded.

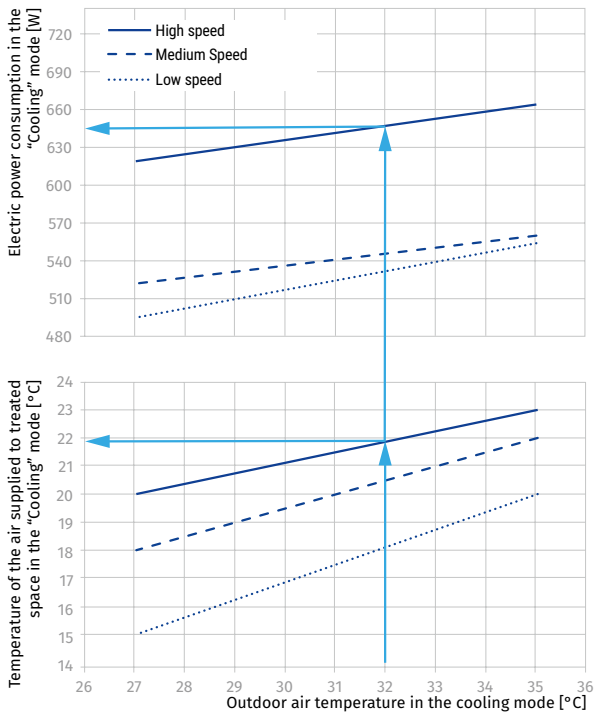

Heat pump characteristics in the "HEATING" mode

KOMFORT ROTO EC L(E)HP 700

Speed	Air flow rate		Room air temperature [°C]		Temperature at fresh air intake [°C]		Temperature of outdoor air supplied to treated space [°C]		Electric power consumption [kW]	COP* ₁ [W/W]	COP* ₂ [BTU/W]	Q _{heat,1} [kW]
	% of max	[m³/h]	Dry-bulb temperature	Wet-bulb temperature (relative humidity)	Dry-bulb temperature	Wet-bulb temperature (relative humidity)	Dry-bulb temperature	Wet-bulb temperature (relative humidity)				
High	100	700	20	12 (~38 %)	7	6 (~86 %)	26	14 (~25 %)	0.695	6.4	21.8	4.43
Medium	70	490	20	12 (~38 %)	7	6 (~86 %)	28	15 (~23 %)	0.580	5.9	20.2	3.43
Low	40	280	20	12 (~38 %)	7	6 (~86 %)	35	17 (~14 %)	0.520	5.0	17.1	2.61
High	100	700	20	12 (~38 %)	2	1 (~80 %)	25	12 (~18 %)	0.690	7.8	26.5	5.37
Medium	70	490	20	12 (~38 %)	2	1 (~80 %)	27	13 (~17 %)	0.570	7.2	24.4	4.08
Low	40	280	20	12 (~38 %)	2	1 (~80 %)	34	16 (~12.5 %)	0.505	5.9	20.2	2.99
High	100	700	20	12 (~38 %)	-7	-8 (~70 %)	21	8 (~8 %)	0.670	10.4	35.6	7.00
Medium	70	490	20	12 (~38 %)	-7	-8 (~70 %)	22	9 (~8 %)	0.555	9.1	31.1	5.06
Low	40	280	20	12 (~38 %)	-7	-8 (~70 %)	25	10 (~8 %)	0.485	6.5	22.3	3.17

*Important! The temperature parameters and the COP and ERR factors were defined at the temperature-humidity conditions as per the EN 13141 -7:2010 standard. The factors were calculated based on the assumption of continuous heat pump operation whereas the cyclic heat pump operation was disregarded.

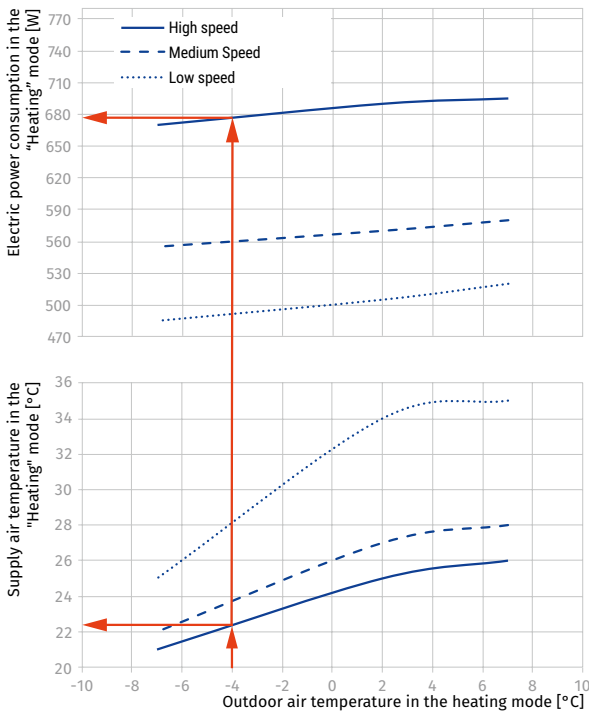

Heat pump characteristics in the "COOLING" mode

KOMFORT ROTO EC L(E)HP 700

Speed	Air flow rate		Room air temperature [°C]		Temperature at fresh air intake [°C]		Temperature of outdoor air supplied to treated space [°C]		Electric power consumption [kW]	COP*, [W/W]	COP*, [BTU/W]	Q _{cool} [kW]
	% of max	[m³/h]	Dry-bulb temperature	Wet-bulb temperature (relative humidity)	Dry-bulb temperature	Wet-bulb temperature (relative humidity)	Dry-bulb temperature	Wet-bulb temperature (relative humidity)				
High	100	700	27	19 (~47.5 %)	35	24 (~40 %)	23	21 (~85 %)	0.780	3.6	12.2	2.8
Medium	70	490	27	19 (~47.5 %)	35	24 (~40 %)	22	20.5 (~85 %)	0.660	3.2	11	2.12
Low	40	280	27	19 (~47.5 %)	35	24 (~40 %)	20	19 (~90 %)	0.605	2.9	10	1.77
High	100	700	27	19 (~47.5 %)	27	19 (~47.5 %)	19	16.5 (~78 %)	0.735	2.5	8.7	1.87
Medium	70	490	27	19 (~47.5 %)	27	19 (~47.5 %)	18	15.5 (~78 %)	0.580	2.5	8.6	1.47
Low	40	280	27	19 (~47.5 %)	27	19 (~47.5 %)	15	14 (~88 %)	0.540	2.2	7.7	1.21

*Important! The temperature parameters and the COP and ERR factors were defined at the temperature-humidity conditions as per the EN 13141 -7:2010 standard. The factors were calculated based on the assumption of continuous heat pump operation whereas the cyclic heat pump operation was disregarded.

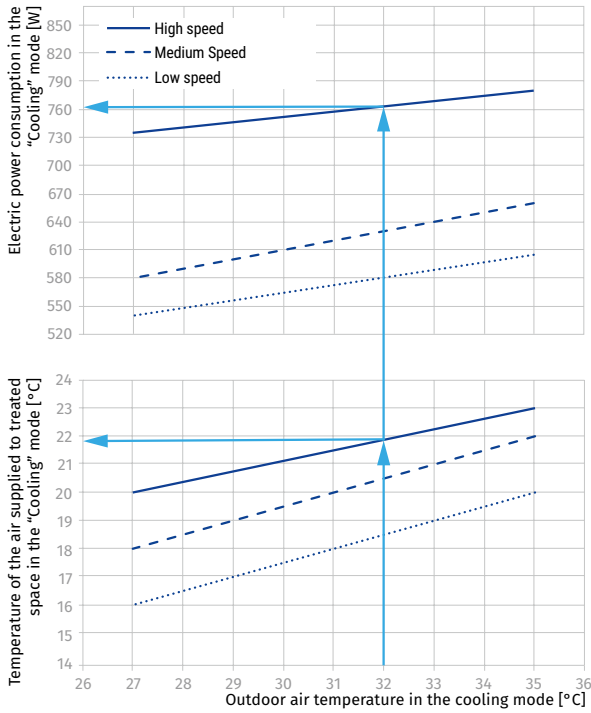

Heat pump characteristics in the "HEATING" mode

KOMFORT ROTO EC L(E)HP 900

Speed	Air flow rate		Room air temperature [°C]		Temperature at fresh air intake [°C]		Temperature of outdoor air supplied to treated space [°C]		Electric power consumption [kW]	COP* ₁ [W/W]	COP* ₂ [BTU/W]	Q _{heat,1} [kW]
	% of max	[m³/h]	Dry-bulb temperature	Wet-bulb temperature (relative humidity)	Dry-bulb temperature	Wet-bulb temperature (relative humidity)	Dry-bulb temperature	Wet-bulb temperature (relative humidity)				
High	100	900	20	12 (~38 %)	7	6 (~86 %)	26	14 (~25 %)	855	6.7	22.7	5.70
Medium	70	630	20	12 (~38 %)	7	6 (~86 %)	28	15 (~23 %)	750	5.9	20.1	4.41
Low	40	360	20	12 (~38 %)	7	6 (~86 %)	35	17 (~14 %)	695	4.8	16.5	3.36
High	100	900	20	12 (~38 %)	2	1 (~80 %)	25	12 (~18 %)	847	8.1	27.8	6.90
Medium	70	630	20	12 (~38 %)	2	1 (~80 %)	27	13 (~17 %)	735	7.1	24.4	5.25
Low	40	360	20	12 (~38 %)	2	1 (~80 %)	34	16 (~12.5 %)	680	5.6	19.3	3.84
High	100	900	20	12 (~38 %)	-7	-8 (~70 %)	20	8 (~8 %)	818	11.0	37.5	9.00
Medium	70	630	20	12 (~38 %)	-7	-8 (~70 %)	21	9 (~8 %)	700	9.3	31.7	6.51
Low	40	360	20	12 (~38 %)	-7	-8 (~70 %)	23	10 (~14 %)	643	6.3	21.7	4.08

*Important! The temperature parameters and the COP and ERR factors were defined at the temperature-humidity conditions as per the EN 13141 -7:2010 standard. The factors were calculated based on the assumption of continuous heat pump operation whereas the cyclic heat pump operation was disregarded.

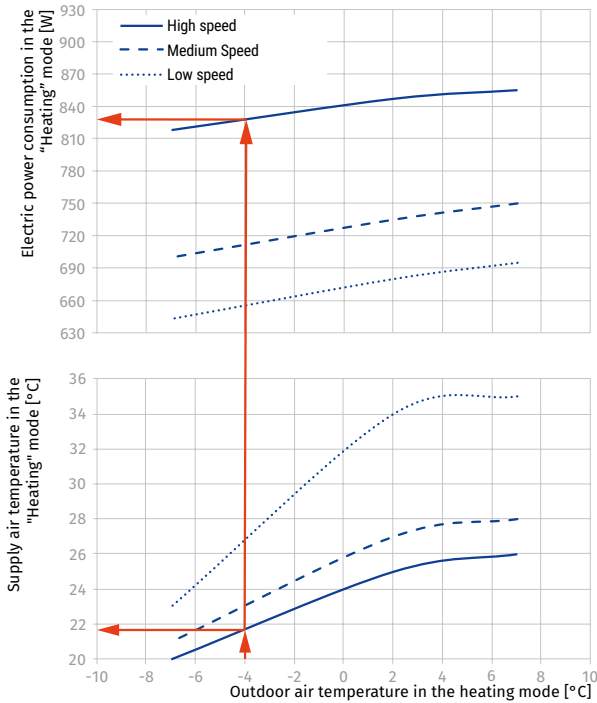

AIR HANDLING UNITS WITH ROTARY HEAT EXCHANGER

Heat pump characteristics in the "COOLING" mode







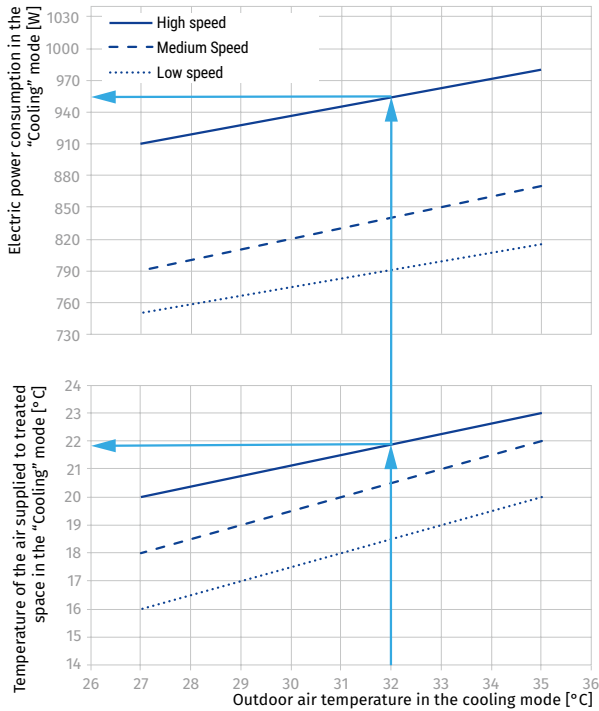





KOMFORT ROTO EC L(E)HP 900

Speed	Air flow rate		Room air temperature [°C]		Temperature at fresh air intake [°C]		Temperature of outdoor air supplied to treated space [°C]		Electric power consumption [kW]	COP*, [W/W]	COP*, [BTU/W]	Q _{cool} [kW]
	% of max	[m³/h]	Dry-bulb temperature	Wet-bulb temperature (relative humidity)	Dry-bulb temperature	Wet-bulb temperature (relative humidity)	Dry-bulb temperature	Wet-bulb temperature (relative humidity)				
High	100	900	27	19 (~47.5 %)	35	24 (~40 %)	23	21 (~85 %)	0.980	3.7	12.5	3.60
Medium	70	630	27	19 (~47.5 %)	35	24 (~40 %)	22	20.5 (~85 %)	0.870	3.1	10.7	2.73
Low	40	360	27	19 (~47.5 %)	35	24 (~40 %)	20	19 (~90 %)	0.815	2.8	9.5	2.28
High	100	900	27	19 (~47.5 %)	27	19 (~47.5 %)	19	16.5 (~78 %)	0.910	2.6	9	2.40
Medium	70	630	27	19 (~47.5 %)	27	19 (~47.5 %)	18	15.5 (~78 %)	0.790	2.4	8.2	1.89
Low	40	360	27	19 (~47.5 %)	27	19 (~47.5 %)	15	14 (~88 %)	0.750	2.1	7.1	1.56

*Important! The temperature parameters and the COP and ERR factors were defined at the temperature-humidity conditions as per the EN 13141 -7:2010 standard. The factors were calculated based on the assumption of continuous heat pump operation whereas the cyclic heat pump operation was disregarded.



Accessories

		KOMFORT Roto EC L(E)HP 400 S17/S18	KOMFORT Roto EC L(E)HP 700 S17/S18	KOMFORT Roto EC L(E)HP 900 S17/S18
G4 panel filter		FP 600x332x48 G4	FP 700x352x48 G4	FP 700x352x48 G4
G4 pocket filter		FPT 600x330x27 G4	FPT 700x351x27 G4	FPT 700x351x27 G4
F7 pocket filter		FPT 600x330x27 F7	FPT 700x351x27 F7	FPT 700x351x27 F7
Backdraft air damper		VRV 160	VRV 250	VRV 250
Air damper		VKA 160	VKA 250	VKA 250
Humidity sensor		FS2	FS2	FS2
Humidity sensor		HR-S	HR-S	HR-S
VOC sensor		DPWQ30600	DPWQ30600	DPWQ30600
External CO ₂ sensor		DPWQ40200	DPWQ40200	DPWQ40200
Humidity sensor		DPWC11200	DPWC11200	DPWC11200
Electric actuator		LF230	LF230	LF230
Electric actuator		TF230	TF230	TF230

KOMFORT Roto EC LE/LW

Air handling units with rotary heat exchanger

Features

- Air handling units for efficient supply and exhaust ventilation in flats, houses, cottages and other buildings.
- Used to create controlled energy-saving ventilation systems.
- The heat recovery technology is used to minimize ventilation heat losses.
- Control of air exchange for creating comfortable indoor microclimate.
- Compatible with round Ø 160, 250 or 315 mm air ducts. **KOMFORT Roto EC LE/LW 2000** are designed for connection to 500x300 mm rectangular air ducts.



Air flow:
up to 2250 m³/h
625 l/s



Heat recovery efficiency:
up to 95 %



Design

- **KOMFORT Roto EC LE** – model with electric heater.
- **KOMFORT Roto EC LW** – model with water heater.
- The casing is made of double-skinned aluzinc panels, internally filled with 20–25 mm mineral wool layer for heat- and sound-insulation.
- The casing has mounting brackets with anti-vibration rubber mounts for easy installation.
- The spigots are located at the sides of the unit and are equipped with rubber seals for airtight connection to the air ducts.
- The hinged side panels ensure easy access to the internals for service works including cleaning, filter replacement, etc.

Air filtration

- The built-in G4 supply filter and G4 extract filter provide air filtration.

Fans

- The unit is equipped with high-efficient external rotor EC motors and centrifugal impellers with backward curved blades.
- EC motors have the best power consumption to air flow ratio and meet the latest demands concerning energy saving and high-efficient ventilation.
- EC motors are featured with high performance, low noise level and totally controllable speed range.
- The impellers are dynamically balanced.

Mounting

- The unit can be installed on the floor, suspended to the ceiling or fixed to the wall by means of mounting brackets.
- The correct mounted unit must provide condensate collecting and drainage and free access to the hinged side panel for servicing and filter replacement.
- Access on the left side.

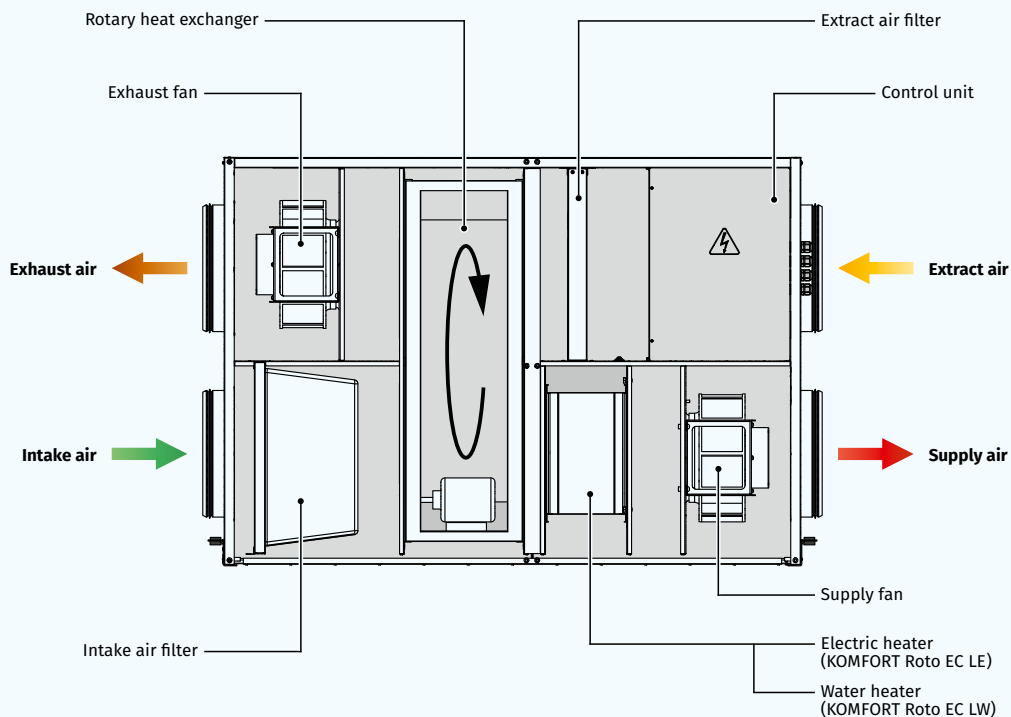

AIR HANDLING UNITS WITH ROTARY HEAT EXCHANGER

Heat recovery

- The unit has a high-efficient rotary aluminium heat exchanger.
- The rotary regenerator is a short, rotating cylinder, filled with corrugated aluminium sheet layers. The air streams flow through them.
- The band layers of the heat regenerator first come in contact with the supply and then with extract air flows.
- Therefore the band is alternatively warmed up and cooled down and the extract air heat and humidity are transferred to the cold intake air. This way heat recovery reduces heat losses in the cold season and reduces operation load for air conditioner in the warm season.
- The advantages of the rotary regenerator as compared to the plate heat exchangers include no condensate generation, maintaining comfort air humidity and high freeze resistance.

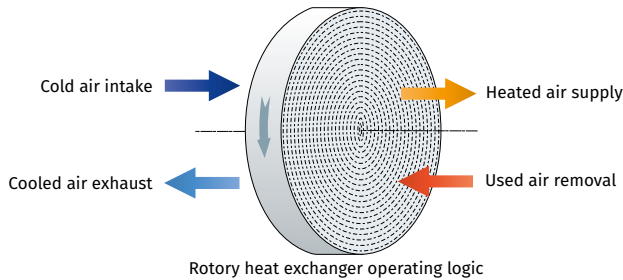

- For overheating protection the electro heater is equipped with two built-in thermal switches: with +60 °C operating temperature, automatic restart, and with +90 °C operating temperature, manual restart.
- **KOMFORT Roto EC LW** are equipped with a water (glycol) heater for operation at low outside temperatures.
- Smooth water heater control ensures automatic maintenance of supply air temperature.
- The air temperature sensor downstream of the heater and the return water temperature sensor are used for freezing protection of the water heater.
- Water heaters are designed for operation with maximum operating pressure of 1 MPa (10 bar) and maximum heat medium operating temperature +95 °C.
- The spigots of water heater are located on service panel side.

Control and automation

- **KOMFORT Roto EC LE S17** and **KOMFORT Roto EC LW S17** are equipped with the th-Tune control panel.
- **KOMFORT Roto EC LE S18** and **KOMFORT Roto EC LW S18** are equipped with the pGD1 control panel.
- **Automation functions:**
 - Fan speed selection: low, high or medium.
 - Speed setting from 0 to 100 % for supply and exhaust fans separately
 - Filter maintenance indication
 - Alarm indication
 - Timer-based operation of the unit
 - Week-scheduled operation of the unit
 - Control and regulation of supply air temperature
 - CCU controlling
 - Air damper actuator controlling



Heater

- The integrated heater is activated to warm up supply air flow if set indoor air temperature may not be reached by means of heat recovery only.
- **KOMFORT Roto EC LE** are equipped with an electric heater for operation at low outside temperatures.
 - Smooth electric heater output control ensures automatic maintenance of supply air temperature.

Designation key

Series	Unit type	Motor type	Spigot modification	Heater type	Rated air flow [m³/h]	Heater parameters	Control
KOMFORT	Roto: rotary heat exchanger	EC: electronically commutated motor	L: horizontal spigot orientation	E: electric heater W: water heater	400; 700; 900; 1200; - 1500; 2000	2; 3.3; ...: heater power [kW] (electric heater) 2: heater rows (water heater)	S17: thTune control panel S18: pGD1 control panel

Overall dimensions [mm]

Model	D	B	B1	H	L	X	Y
KOMFORT Roto EC LE/LW 400	159	648	440	670	1050	-	-
KOMFORT Roto EC LE/LW 700	249	745	580	700	1210	-	-
KOMFORT Roto EC LE/LW 1000	249	745	580	700	1210	-	-
KOMFORT Roto EC LE/LW 1200	314	745	460	880	1335	-	-
KOMFORT Roto EC LE/LW 1500	314	855	560	1010	1430	-	-
KOMFORT Roto EC LE/LW 2000	-	875	630	1010	1485	500	300

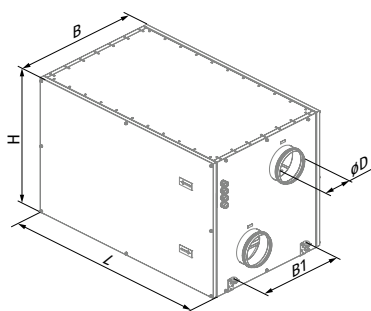

KOMFORT Roto EC LE/LW 400 / Roto EC LE/LW 700 / Roto EC LE/LW 1000

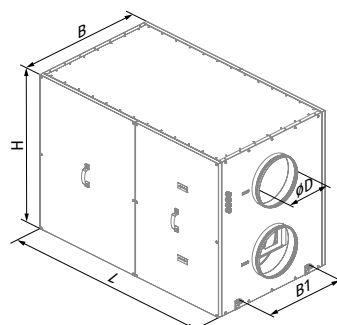

KOMFORT Roto EC LE/LW 1200 / Roto EC LE/LW 1500

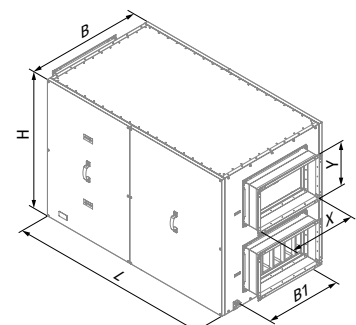

KOMFORT Roto EC LE/LW 2000

Technical data

Parameters	KOMFORT Roto EC LE 400-2 S17/S18	KOMFORT Roto EC LE 700-3.3 S17/S18	KOMFORT Roto EC LE 1000-4.5 S17/S18	KOMFORT Roto EC LE 1200-6 S17/S18	KOMFORT Roto EC LE 1500-9 S17/S18	KOMFORT Roto EC LE 2000-12 S17/S18
Voltage [V / 50 (60) Hz]	1 ~ 230	1 ~ 230	3 ~ 400	3 ~ 400	3 ~ 400	3 ~ 400
Motor max. power [W]	2 items x 100	2 items x 105	2 items x 135	2 items x 208	2 items x 222	2 items x 448
Electric heater power [W]	2000	3300	4500	6000	9000	12000
Max. power with electric heater [W]	2290	3615	4940	6570	9750	13070
Max. current with electric heater [A]	9.9	15.8	7.2	9.5	14.1	22.4
Maximum air flow [m ³ /h (l/s)]	400 (111)	700 (194)	900 (250)	1200 (333)	1500 (417)	2250 (625)
RPM [min ⁻¹]	up to 3100	up to 2600	up to 2600	up to 1930	up to 2000	up to 3000
Sound pressure level at 3 m [dBA]	45	52	58	60	62	64
Transported air temperature [°C]	-25...+40	-25...+40	-25...+40	-25...+40	-25...+40	-25...+40
Casing material	aluzinc	aluzinc	aluzinc	aluzinc	aluzinc	aluzinc
Insulation	20 mm mineral wool	20 mm mineral wool	20 mm mineral wool	20 mm mineral wool	25 mm mineral wool	25 mm mineral wool
Extract filter	G4	G4	G4	G4	G4	G4
Supply filter	G4	G4	G4	G4	G4	G4
Connected air duct diameter [mm]	160	250	250	315	315	500x300
Weight [kg]	112	128	130	165	175	198
Heat recovery efficiency [%]	80-95	76-95	72-95	73-95	72-95	68-93
Heat exchanger type	rotary	rotary	rotary	rotary	rotary	rotary
Heat exchanger material	aluminium	aluminium	aluminium	aluminium	aluminium	aluminium
SEC class	A	A	A	NRVU*	NRVU*	NRVU*
ErP	2016, 2018	2016, 2018	2016, 2018	2016, 2018	2016, 2018	2016, 2018

*Nonresidential Ventilation Unit.

AIR HANDLING UNITS WITH ROTARY HEAT EXCHANGER

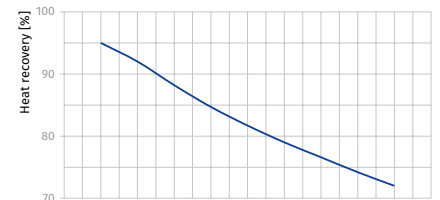
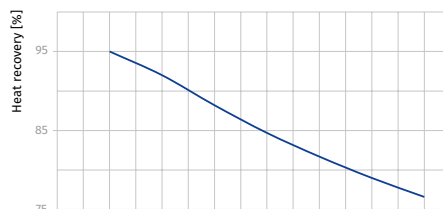
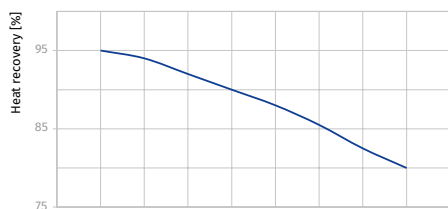
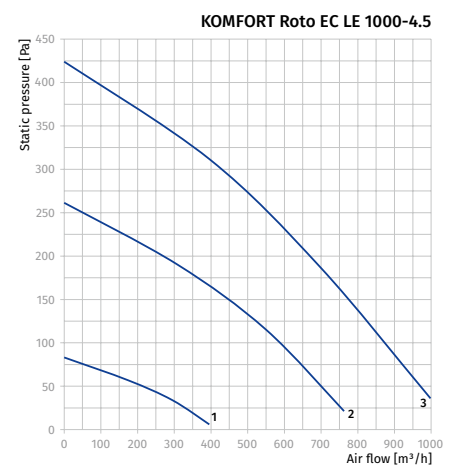
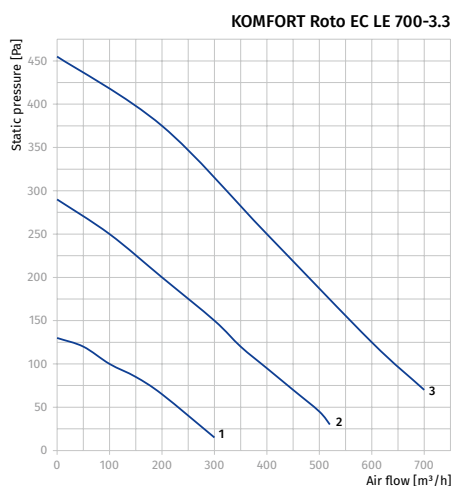
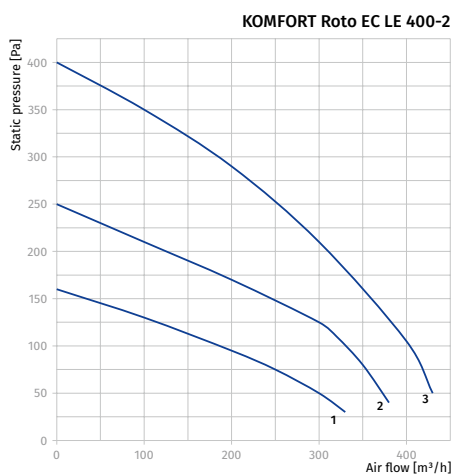

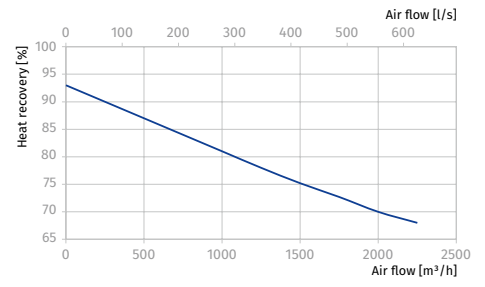
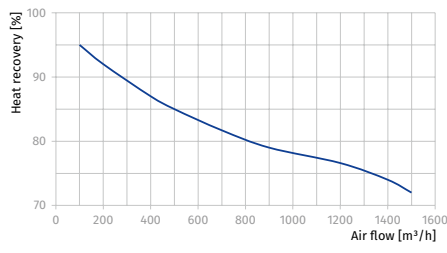
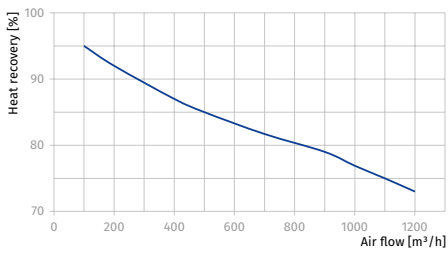
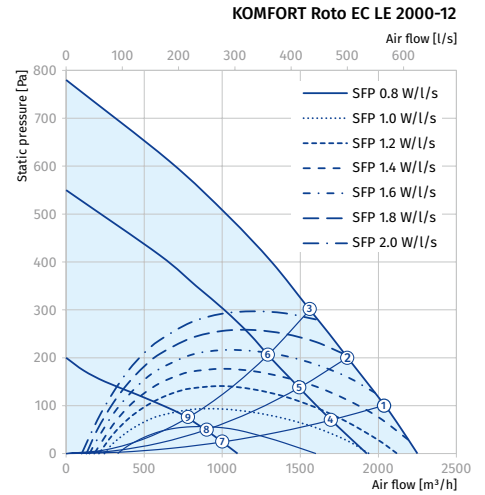
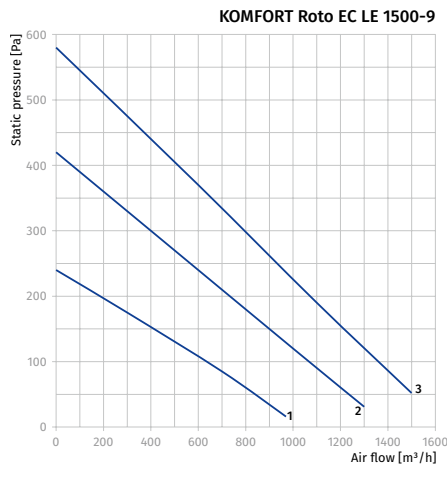
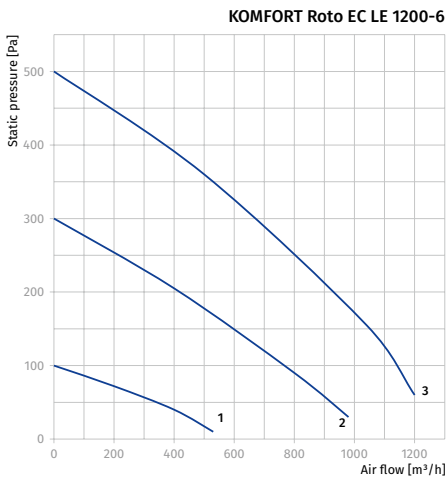

Total power of the unit, W

Point	KOMFORT Roto EC LE 2000-12
1	874
2	893
3	905
4	545
5	562
6	568
7	181
8	182
9	184

Parameters	KOMFORT Roto EC LW 400-2 S17/S18	KOMFORT Roto EC LW 700-2 S17/S18	KOMFORT Roto EC LW 1000-2 S17/S18	KOMFORT Roto EC LW 1200-2 S17/S18	KOMFORT Roto EC LW 1500-2 S17/S18	KOMFORT Roto EC LW 2000-2 S17/S18
Voltage [V / 50 (60) Hz]	1 ~ 230	1 ~ 230	1 ~ 230	1 ~ 230	1 ~ 230	1 ~ 230
Max. power without electric heater [W]	2 items x 100	2 items x 105	2 items x 135	2 items x 208	2 items x 222	2 items x 448
Max. power with electric heater [W]	290	315	440	570	750	1070
Max. current with electric heater [A]	1.2	1.4	1.9	2.5	3.2	5
Maximum air flow [m³/h (l/s)]	400 (111)	700 (194)	900 (250)	1200 (333)	1500 (417)	2250 (625)
RPM [min ⁻¹]	up to 3100	up to 2600	up to 2600	up to 1930	up to 2000	up to 3000
Sound pressure level at 3 m [dBA]	45	52	58	60	62	64
Transported air temperature [°C]	-25...+40	-25...+40	-25...+40	-25...+40	-25...+40	-25...+40
Casing material	aluzinc	aluzinc	aluzinc	aluzinc	aluzinc	aluzinc
Insulation	20 mm mineral wool	20 mm mineral wool	20 mm mineral wool	20 mm mineral wool	25 mm mineral wool	25 mm mineral wool
Extract filter	G4	G4	G4	G4	G4	G4
Supply filter	G4	G4	G4	G4	G4	G4
Connected air duct diameter [mm]	160	250	250	315	315	500x300
Weight [kg]	112	128	130	165	175	198
Heat recovery efficiency [%]	80-95	76-95	72-95	73-95	72-95	68-93
Heat exchanger type	up to 85	up to 85	up to 85	up to 85	up to 85	up to 85
Heat exchanger type	rotary	rotary	rotary	rotary	rotary	rotary
Heat exchanger material	aluminium	aluminium	aluminium	aluminium	aluminium	aluminium
SEC class	A	A	A	NRVU*	NRVU*	NRVU*
ErP	2016, 2018	2016, 2018	2016, 2018	2016, 2018	2016, 2018	2016, 2018

*Nonresidential Ventilation Unit.

AIR HANDLING UNITS WITH ROTARY HEAT EXCHANGER

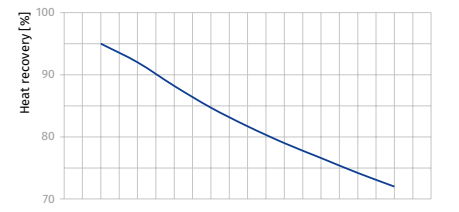
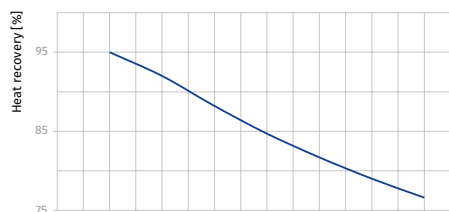
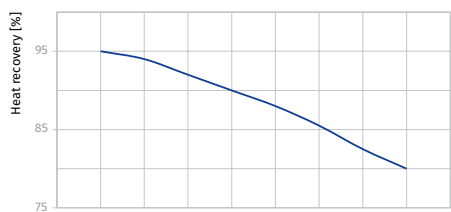
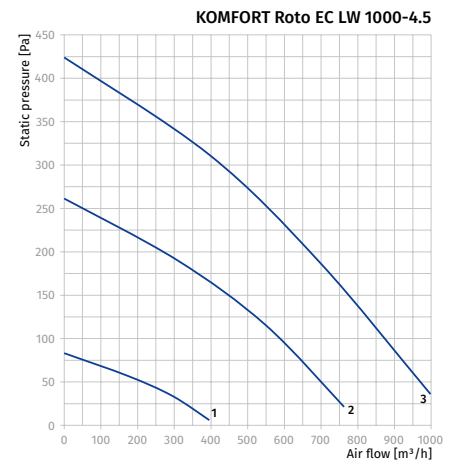
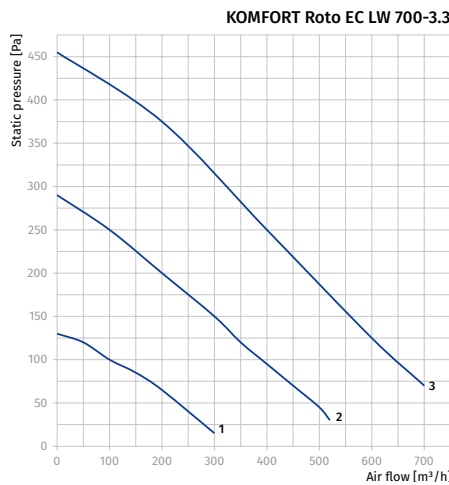
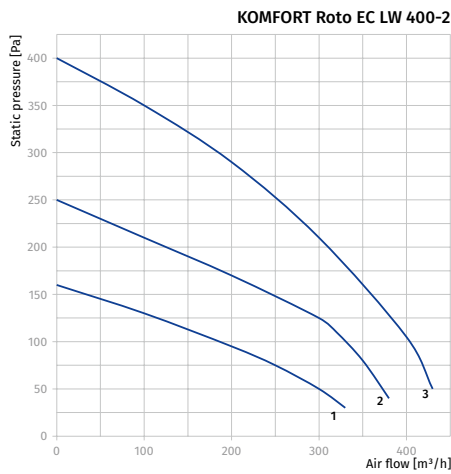

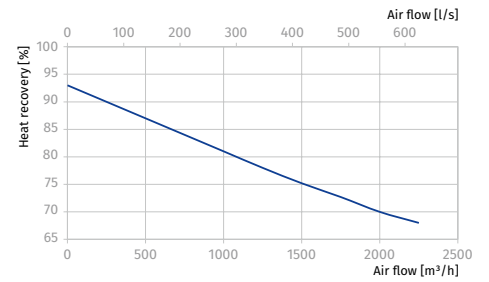
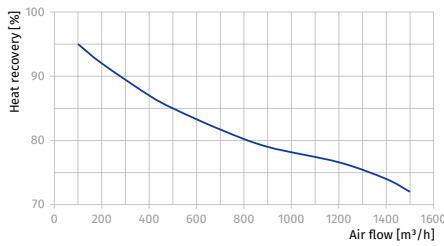
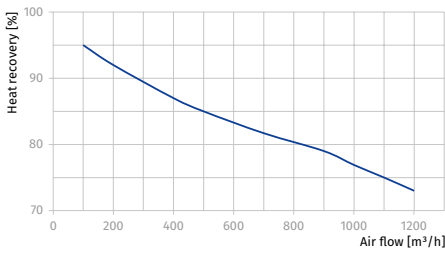
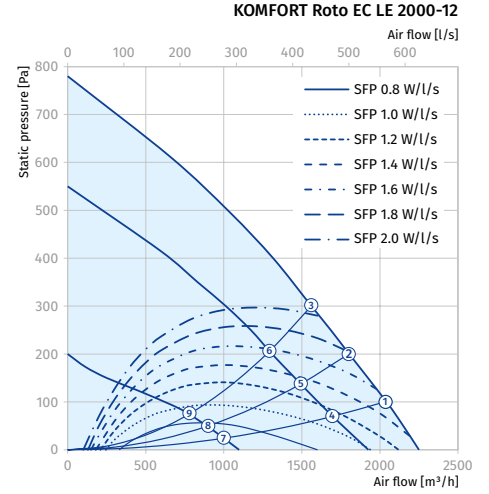
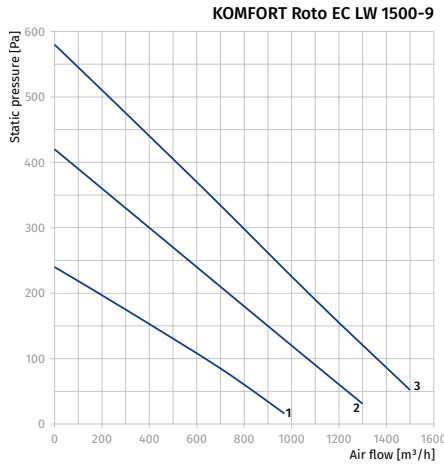
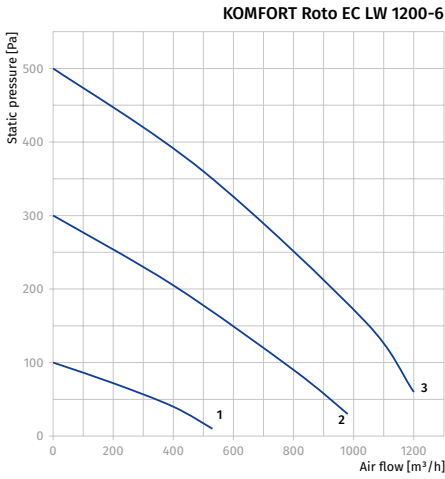

Total power of the unit, W

Point	KOMFORT Roto EC LE 2000-12
1	874
2	893
3	905
4	545
5	562
6	568
7	181
8	182
9	184

Calculation of water heater parameters of the unit

KOMFORT Roto EC LW 400-2 / KOMFORT Roto EC LW 700-2 / KOMFORT Roto EC LW 1000-2

Air temperature downstream of the water heating coils [°C]

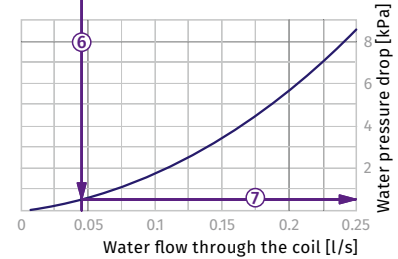
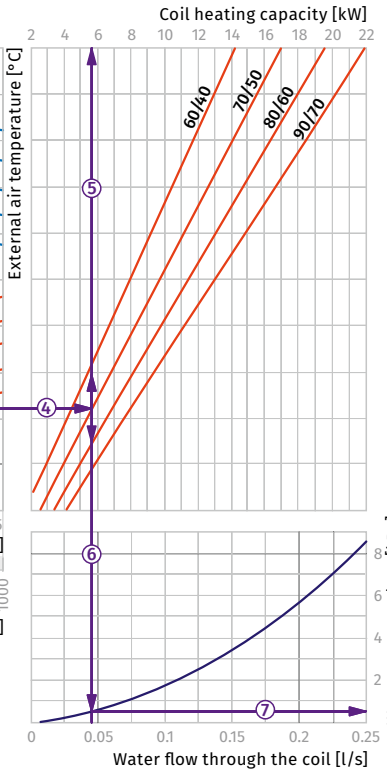
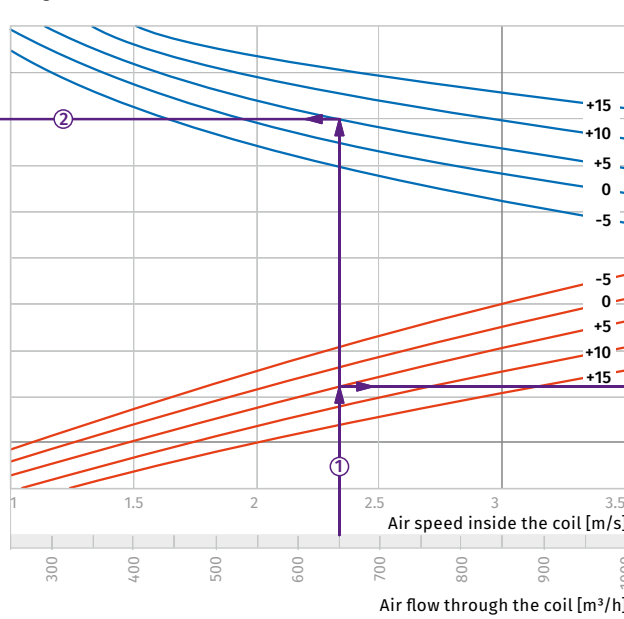
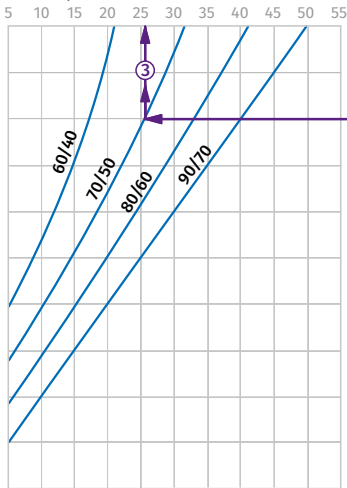

How to use water heater diagrams.

Sample parameters: Air flow = 650 m³/h.
Outside air temperature = +5 °C.
Water temperature (in/out) = +70/+50 °C.
The air flow is 650 m³/h and the air speed in the heater is 2.35 m/s ①.

- To calculate the maximum air temperature find the intersection point of the air flow line ① with the rated outer temperature shown in blue line (e.g., +5 °C) and draw the line ② to the left until it crosses the water in/out temperature curve (e.g., +70/+50). From this point draw a vertical line to the supply air temperature downstream of the heater (+26 °C) ③.

- To calculate the heater power find the intersection point of the air flow ① with the rated winter temperature shown in red line (e.g., +5 °C) and draw the line ④ to the right until it crosses the water in/out temperature curve (e.g., +70/+50). From this point draw a vertical line to the heater power axis (5.8 kW) ⑤.

- To calculate the required water flow in the heater prolong this line ⑥ downwards to the water flow axis (0.04 l/s).
- To calculate the water pressure drop in the heater find the intersection point of the line ⑥ with the pressure loss curve and prolong the line ⑦ to the right on the water pressure drop axis (0.5 kPa).

KOMFORT ROTO EC LW 1200-2

Air temperature downstream of the water heating coils [°C]

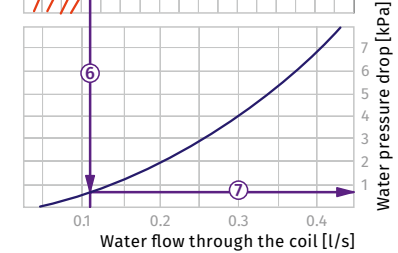
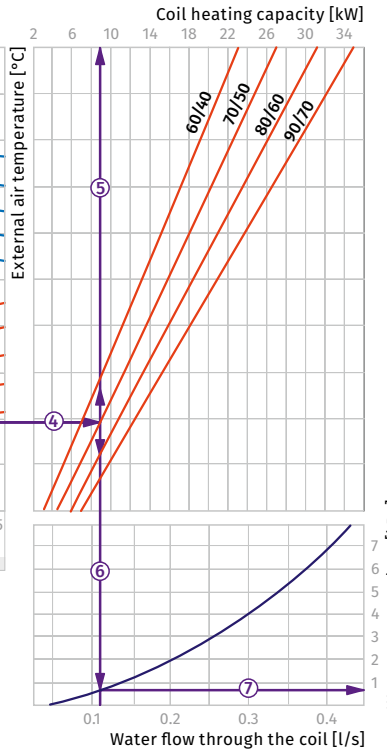
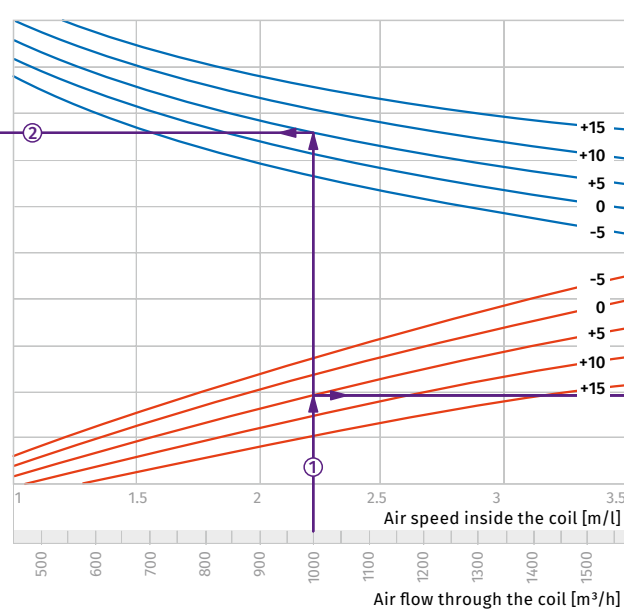
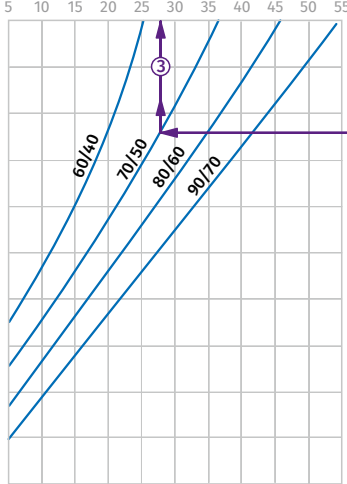

How to use water heater diagrams.

Sample parameters: Air flow = 1000 m³/h.
Outside air temperature = +5 °C.
Water temperature (in/out) = +70/+50 °C.
The air flow is 1000 m³/h and the air speed in the heater is 2.22 m/s ①.

- To calculate the maximum air temperature find the intersection point of the air flow line ① with the rated outer temperature shown in blue line (e.g., +5 °C) and draw the line ② to the left until it crosses the water in/out temperature curve (e.g., +70/+50). From this point draw a vertical line to the supply air temperature downstream of the heater (+28 °C) ③.

- To calculate the heater power find the intersection point of the air flow ① with the rated winter temperature shown in red line (e.g., +5 °C) and draw the line ④ to the right until it crosses the water in/out temperature curve (e.g., +70/+50). From this point draw a vertical line to the heater power axis (9.0 kW) ⑤.

- To calculate the required water flow in the heater prolong this line ⑥ downwards to the water flow axis (0.11 l/s).
- To calculate the water pressure drop in the heater find the intersection point of the line ⑥ with the pressure loss curve and prolong the line ⑦ to the right on the water pressure drop axis (0.8 kPa).

AIR HANDLING UNITS WITH ROTARY HEAT EXCHANGER

KOMFORT ROTO EC LW 1500-2 / KOMFORT ROTO EC LW 2000-2

Air temperature downstream of the water heating coils [°C]

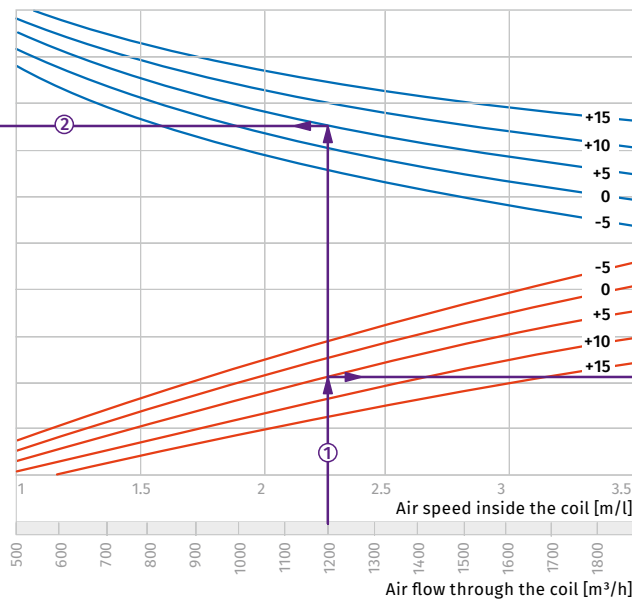
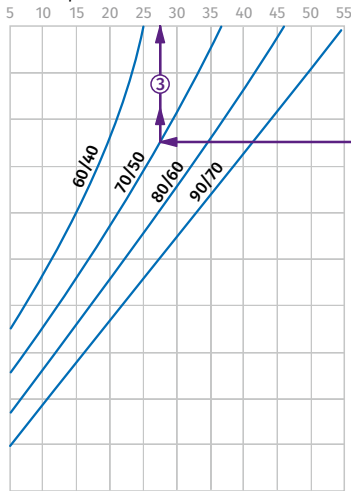

Coil heating capacity [kW]

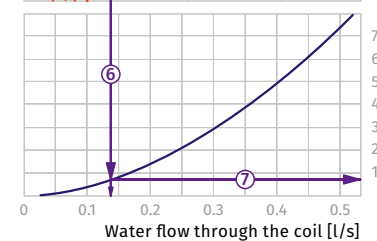
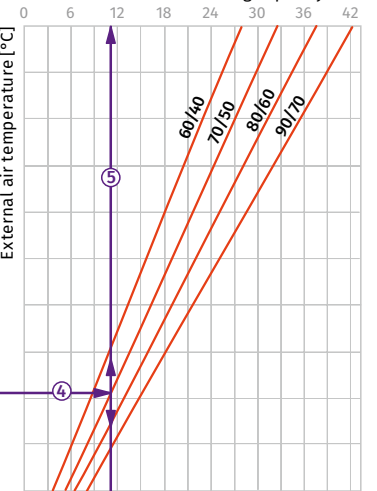

How to use water heater diagrams.













Sample parameters: Air flow = 1200 m³/h.
 Outside air temperature = +5 °C.
 Water temperature (in/out) = +70/+50 °C.
 The air flow is 1200 m³/h and the air speed in the heater is 2.25 m/s ①.

- To calculate the maximum air temperature find the intersection point of the air flow line ① with the rated outer temperature shown in blue line (e.g., +5 °C) and draw the line ② to the left until it crosses the water in/out temperature curve (e.g., +70/+50). From this point draw a vertical line to the supply air temperature downstream of the heater (+27 °C) ③.

- To calculate the heater power find the intersection point of the air flow ① with the rated winter temperature shown in red line (e.g., +5 °C) and draw the line ④ to the right until it crosses the water in/out temperature curve (e.g., +70/+50). From this point draw a vertical line to the heater power axis (11.0 kW) ⑤.

- To calculate the required water flow in the heater prolong this line ⑥ downwards to the water flow axis (0.13 l/s).
- To calculate the water pressure drop in the heater find the intersection point of the line ⑥ with the pressure loss curve and prolong the line ⑦ to the right on the water pressure drop axis (0.8 kPa).

Accessories
KOMFORT ROTO EC LE

		KOMFORT Roto EC LE 400-2 S17/S18	KOMFORT Roto EC LE 700-3.3 S17/S18	KOMFORT Roto EC LE 1000-4.5 S17/S18	KOMFORT Roto EC LE 1200-6 S17/S18	KOMFORT Roto EC LE 1500-9 S17/S18	KOMFORT Roto EC LE 2000-12 S17/S18
G4 extract panel filter		FP 600x324x48 G4	FP 700x332x48 G4	FP 700x332x48 G4	FP 700x410x48 G4	FP 800x477x47 G4	FP 800x477x47 G4
G4 supply pocket filter		FPT 393x235x27 G4	FPT 700x333x27 G4	FPT 700x333x27 G4	FPT 700x423x27 G4	FPT 800x477x27 G4	FPT 800x477x27 G4
Silencer		SD 160	SD 250	SD 250	SD 315	SD 315	-
Backdraft air damper		VRV 160	VRV 250	VRV 250	VRV 315	VRV 315	-
Backdraft air damper		-	-	-	-	-	VRVS 500x300
Air damper		VRVS 160	VRVS 250	VRVS 250	VRVS 315	VRVS 315	-
Air damper		-	-	-	-	-	VK 500x300
VOC sensor		DPWQ30600	DPWQ30600	DPWQ30600	DPWQ30600	DPWQ30600	DPWQ30600
External CO ₂ sensor		DPWQ40200	DPWQ40200	DPWQ40200	DPWQ40200	DPWQ40200	DPWQ40200
Humidity sensor		DPWC11200	DPWC11200	DPWC11200	DPWC11200	DPWC11200	DPWC11200
Humidity sensor		HR-S	HR-S	HR-S	HR-S	HR-S	HR-S
Humidity sensor		FS2	FS2	FS2	FS2	FS2	FS2
Electric actuator		CM230	CM230	CM230	CM230	CM230	CM230

KOMFORT ROTO EC LW

		KOMFORT Roto EC LW 400-2 S17/S18	KOMFORT Roto EC LW 700-2 S17/S18	KOMFORT Roto EC LW 1000-2 S17/S18	KOMFORT Roto EC LW 1200-2 S17/S18	KOMFORT Roto EC LW 1500-2 S17/S18	KOMFORT Roto EC LW 2000-2 S17/S18
G4 extract panel filter		FP 600x324x48 G4	FP 700x332x48 G4	FP 700x332x48 G4	FP 700x410x48 G4	FP 800x477x47 G4	FP 800x477x47 G4
G4 supply pocket filter		FPT 393x235x27 G4	FPT 700x333x27 G4	FPT 700x333x27 G4	FPT 700x423x27 G4	FPT 800x477x27 G4	FPT 800x477x27 G4
Water mixing unit		WMG 3/4-4	WMG 3/4-4	WMG 3/4-4	WMG 3/4-4	WMG 1-6	WMG 1-6
Silencer		SD 160	SD 250	SD 250	SD 315	SD 315	-
Backdraft air damper		VRV 160	VRV 250	VRV 250	VRV 315	VRV 315	-
Backdraft air damper		-	-	-	-	-	VRVS 500x300
Air damper		VRVS 160	VRVS 250	VRVS 250	VRVS 315	VRVS 315	-
Air damper		-	-	-	-	-	VK 500x300
VOC sensor		DPWQ30600	DPWQ30600	DPWQ30600	DPWQ30600	DPWQ30600	DPWQ30600
External CO ₂ sensor		DPWQ40200	DPWQ40200	DPWQ40200	DPWQ40200	DPWQ40200	DPWQ40200
Humidity sensor		DPWC11200	DPWC11200	DPWC11200	DPWC11200	DPWC11200	DPWC11200
Humidity sensor		HR-S	HR-S	HR-S	HR-S	HR-S	HR-S
Humidity sensor		FS2	FS2	FS2	FS2	FS2	FS2
Electric actuator		TF230	TF230	TF230	TF230	TF230	TF230

AIR HANDLING UNITS WITH ROTARY HEAT EXCHANGER

KOMFORT RoTo EC D S21

Suspended heat recovery air handling units

Features

- Air handling units for efficient supply and exhaust ventilation in flats, houses, cottages and other buildings.
- Heat recovery is provided by the rotary heat exchanger and minimizes ventilation heat losses.
- Controllable air exchange for creating the best suitable indoor microclimate.
- Compatible with round Ø 160 and 200 mm air ducts.
- Additional spigot for kitchen hood air duct connection.



Air flow:
up to 710 m³/h
197 l/s



Heat recovery efficiency:
up to 87 %



Design

- The fan casing is made of galvanized steel, internally filled with mineral wool layer for heat and sound insulation.
- The spigots are located at the sides of the unit and are rubber sealed for airtight connection to the air ducts.
- **KOMFORT Roto EC D(2)** – model without electric heater.
- **KOMFORT Roto EC D(2)E** – model with electric heater.
- The insulation of **KOMFORT Roto EC D(E)** is 40 mm, for **KOMFORT Roto EC D2(E)** is 20 mm.
- Unit maintenance is performed from the bottom panel side.
- The distinctive feature of **KOMFORT Roto EC D2(E)** is a low casing profile.

Kitchen hood

- All the models are equipped with a fifth spigot for connection of the air duct from the kitchen hood.

Air filtration

- Two built-in filters with G4 and F7 filtration class provide efficient supply air filtration. Optionally, a H13 supply air filter may be used.
- The G4 filter is used for extract air filtration.

Motors

- High-efficient external rotor EC motors and centrifugal impellers with forward curved blades are used for air supply and exhaust.
- EC motors have the best power consumption to air flow ratio and meet the latest demands concerning energy saving and high-efficient ventilation.
- EC motors are featured with high performance, low noise level and totally controllable speed range.
- Dynamically balanced impellers.

AIR HANDLING UNITS WITH ROTARY HEAT EXCHANGER



KOMFORT ROTO EC D(E) R (RIGHT SERVICE SIDE)

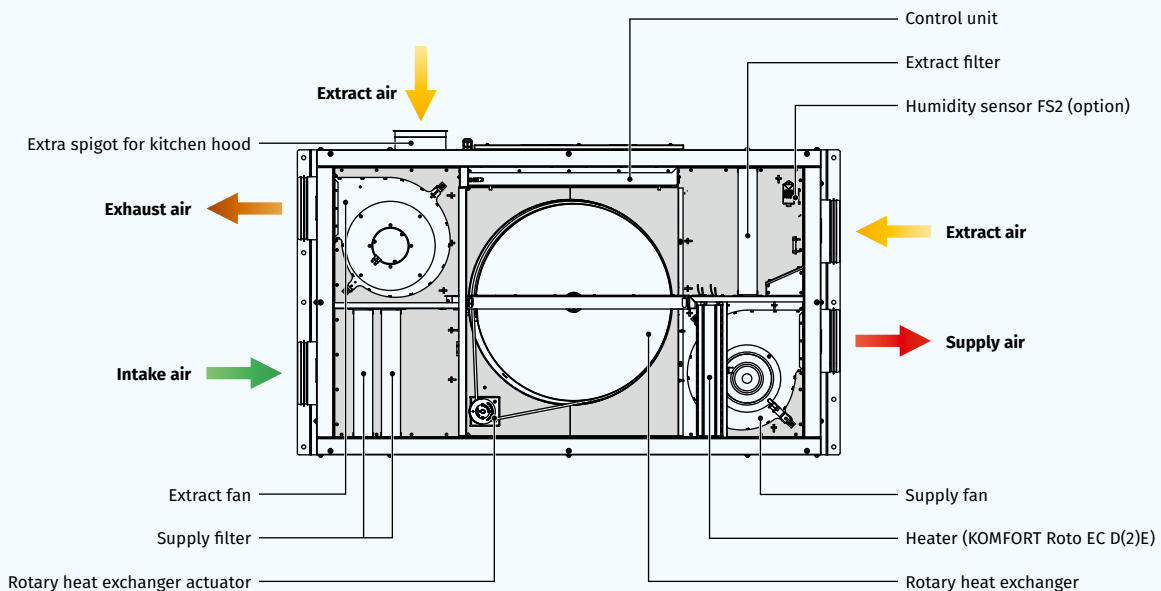

Rotary heat exchanger

- The unit has a high-efficient rotary aluminium heat exchanger.
- The rotary heat exchanger is a short, rotating cylinder, filled with corrugated aluminium sheet layers. The air streams flow through them.
- The band layers of the heat exchanger first come in contact with the supply and then with extract air flows.
- Therefore the band is alternatively warmed up and cooled down and the extract air heat and humidity are transferred to the cold intake air. This way heat recovery reduces heat losses in the cold season and reduces operation load for air conditioner in the warm season.
- The advantages of the rotary heat exchanger as compared to the plate heat exchangers include no condensate generation, maintaining comfort air humidity and high freeze resistance.

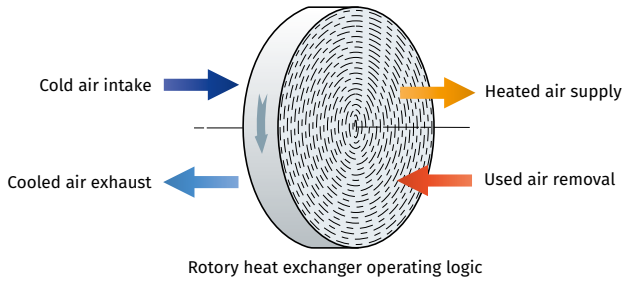

Heater

- The **KOMFORT Roto EC D(2)E** units are equipped with the electric heater. If the necessary temperature level of the supply air cannot be achieved through heat recovery, the heater turns on automatically and heats the air supplied to the premise. The heaters incorporate protective measures securing the safe unit operation.

Mounting

- The air handling unit is designed for suspension to a ceiling, wall mounting or mounting to a horizontal plane.

Control and automation

- **KOMFORT EC D... S21** units are equipped with an integrated automation system. The remote control panel is not included in the delivery set (purchased separately).
- The S21 controller allows integrating the unit into the **Smart Home** system or **BMS (Building Management System)**.
- The unit can be controlled via the **Blauberg AHU** mobile application via Wi-Fi.





Download the **Blauberg AHU** app for Android



Download the **Blauberg AHU** app for iOS



Automation functions

Functions	KOMFORT ROTO EC D(2)(E) S21
Control via Wi-Fi using a mobile application	+
Control via a wired remote control panel	S22 control panel (option) 
Control via a wireless remote control panel	S22 Wi-Fi control panel (option) 
Control via a wired remote LCD control panel	S25 control panel (option) 
BMS (Building Management System)	RS-485
	Wi-Fi
	Ethernet
	MODBUS (RTU, TCP)
Blauberg Cloud Server service	+
Speed selection	+
Filter replacement indication	by filter timer
Alarm indication	full alarm description in the mobile application
Week-scheduled operation	+
Timer	+
Boost mode	+
Fireplace mode	+
Cooler connection	option
Kitchen hood connection	option
Minimum supply air temperature control	+
Humidity control	option
CO ₂ control	option
VOC control	option
PM2.5 control	option
Fire alarm sensor connection	option

Option: function is available when purchasing the appropriate accessory (see the "Accessories" section).

Designation key

Series	Unit type	Motor type	Mounting type	Modification	Heater type	Rated air flow [m ³ /h]	Service side	Control
KOMFORT	Roto: rotary heat exchanger	EC: electronically commutated motor	D: suspended mounting, horizontally directed spigots	_: standard (insulation 40 mm) 2: low-profile (insulation 20 mm)	_: no heater E: electric heater	250; 350; 650	L: left R: right	S21

Overall dimensions [mm]

Model	D	D1	B	B1	H	H1	L	L1
KOMFORT Roto EC D(E) 250 S21	160	125	643	688	308	345	1003	1100
KOMFORT Roto EC D2(E) 250 S21	160	125	618	666	225	245	1002	1097
KOMFORT Roto EC D(E) 350 S21	160	125	770	818	318	361	1270	1365
KOMFORT Roto EC D2(E) 350 S21	160	125	798	847	225	245	1362	1457
KOMFORT Roto EC D(E) 650 S21	200	125	897	932	409	422	1445	1542

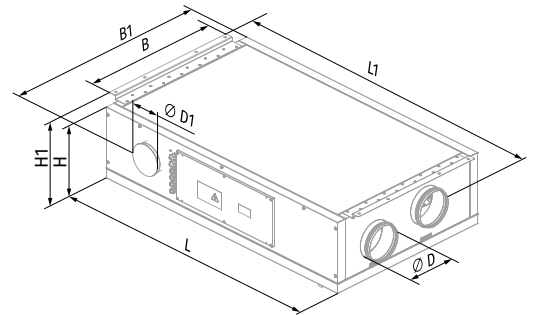

Technical data

Parameters	KOMFORT Roto EC D2 250 S21	KOMFORT Roto EC D2E 250 S21	KOMFORT Roto EC D 250 S21	KOMFORT Roto EC DE 250 S21
Voltage [V / 50 (60) Hz]	1~230	1~230	1~230	1~230
Maximum power [W]	128	828	135	835
Power of electric heater [W]	-	700	-	700
Power without heater [W]	128	128	135	135
Maximum current [A]	0.9	4.0	1.0	4.1
Current of electric heater [A]	-	3.1	-	3.1
Current without heater [A]	0.9	0.9	1.0	1.0
Maximum air flow [m ³ /h (l/s)]	300 (83)	300 (83)	310 (86)	310 (86)
RPM [min ⁻¹]	2200	2200	2200	2200
Sound pressure level at 3 m [dBA]	23	23	21	21
Transported air temperature [°C]	-25...+40	-25...+40	-25...+40	-25...+40
Casing material	galvanized steel	galvanized steel	galvanized steel	galvanized steel
Insulation	20 mm mineral wool	20 mm mineral wool	40 mm mineral wool	40 mm mineral wool
Extract filter	G4	G4	G4	G4
Supply filter	G4, F7 (option: H13)	G4, F7 (option: H13)	G4, F7 (option: H13)	G4, F7 (option: H13)
Connected air duct diameter [mm]	160	160	160	160
Weight [kg]	53	54	55	56
Heat recovery efficiency [%]*	72-87	72-87	71-87	71-87
Heat exchanger type	rotary	rotary	rotary	rotary
Heat exchanger material	aluminum	aluminum	aluminum	aluminum
SEC class	A	A	A	A
ErP	2016, 2018	2016, 2018	2016, 2018	2016, 2018

*Heat recovery efficiency is specified in compliance with EN 13141-7.

KOMFORT ROTO EC D2(E) 250

Sound power level, A-weighted	Total	Octave frequency band [Hz]								LpA 3 m	LpA 1 m
		63	125	250	500	1000	2000	4000	8000		
LWA to supply inlet [dBA]	55	18	39	42	53	50	40	30	19		
LWA to supply outlet [dBA]	72	31	46	59	68	68	60	58	46		
LWA to exhaust inlet [dBA]	50	17	34	39	49	41	34	27	17		
LWA to exhaust outlet [dBA]	65	30	41	55	64	57	52	51	40		
LWA to environment [dBA]	41	8	25	36	35	33	30	29	27	21	31

Data provided for point 1 of the air flow diagram

Total power. Total sound pressure level.

Point	Total power of the unit [W]	Sound pressure level at 3 m (1m) [dBA]
1	93	23 (33)
2	89	23 (33)
3	77	22 (32)
4	41	21 (31)
5	39	19 (29)
6	38	18 (28)
7	17	18 (28)
8	17	17 (27)
9	16	17 (27)

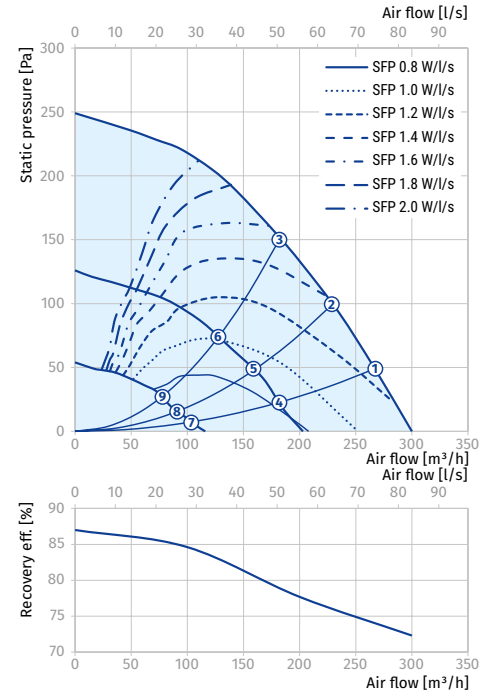

KOMFORT ROTO EC D(E) 250

Sound power level, A-weighted	Total	Octave frequency band [Hz]								LpA 3 m	LpA 1 m
		63	125	250	500	1000	2000	4000	8000		
LWA to supply inlet [dBA]	58	21	42	45	56	53	42	32	21		
LWA to supply outlet [dBA]	59	21	43	45	56	53	42	32	21		
LWA to exhaust inlet [dBA]	53	20	38	42	52	44	36	29	18		
LWA to exhaust outlet [dBA]	54	20	38	43	53	44	36	29	18		
LWA to environment [dBA]	43	10	28	39	38	35	32	31	29	23	33

Data provided for point 1 of the air flow diagram

Total power. Total sound pressure level.

Point	Total power of the unit [W]	Sound pressure level at 3 m (1m) [dBA]
1	101	21 (31)
2	115	21 (31)
3	80	20 (30)
4	45	18 (28)
5	42	17 (27)
6	40	17 (27)
7	17	16 (26)
8	17	16 (26)
9	16	16 (26)

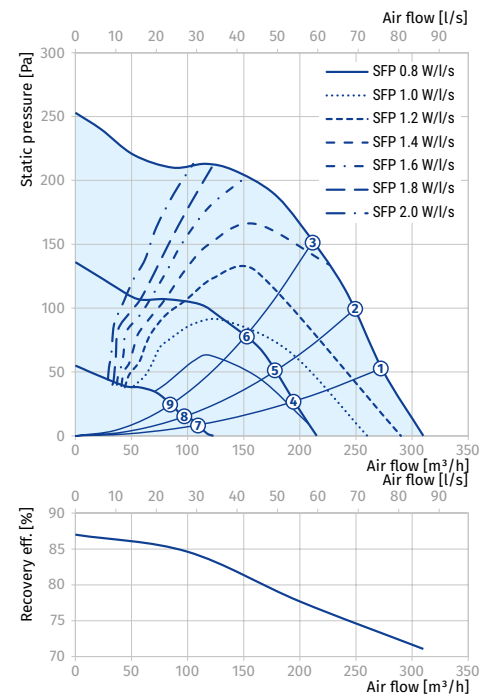

AIR HANDLING UNITS WITH ROTARY HEAT EXCHANGER

Calculation of air temperature downstream of the heat exchanger:

$$t = t_{\text{outd}} + k_{\text{hr}} \times (t_{\text{extr}} - t_{\text{outd}}) / 100,$$

where

t_{outd} – outdoor air temperature [°C]

t_{extr} – extract air temperature [°C]

k_{hr} – heat exchanger efficiency (according to the diagram) [%]

Parameters	KOMFORT Roto EC D2 350 S21	KOMFORT Roto EC D2E 350 S21	KOMFORT Roto EC D 350 S21	KOMFORT Roto EC DE 350 S21	KOMFORT Roto EC D 650 S21	KOMFORT Roto EC DE 650 S21
Voltage [V / 50 (60) Hz]	1~230	1~230	1~230	1~230	1~230	1~230
Maximum power [W]	200	1600	185	1585	367	3167
Power of electric heater [W]	-	1400	-	1400	-	2800
Power without heater [W]	200	200	185	185	367	367
Maximum current [A]	1.3	6.9	1.3	6.9	2.5	13.7
Current of electric heater [A]	-	5.6	-	5.6	-	11.2
Current without heater [A]	1.3	1.3	1.3	1.3	2.5	2.5
Maximum air flow [m³/h (l/s)]	400 (111)	400 (111)	430 (119)	430 (119)	710 (197)	710 (197)
RPM [min⁻¹]	3200	3200	3570	3570	3600	3600
Sound pressure level at 3 m [dBA]	33	33	31	31	36	36
Transported air temperature [°C]	-25...+40	-25...+40	-25...+40	-25...+40	-25...+40	-25...+40
Casing material	galvanized steel	galvanized steel	galvanized steel	galvanized steel	galvanized steel	galvanized steel
Insulation	20 mm mineral wool	20 mm mineral wool	40 mm mineral wool	40 mm mineral wool	40 mm mineral wool	40 mm mineral wool
Extract filter	G4	G4	G4	G4	G4	G4
Supply filter	G4, F7 (option: H13)	G4, F7 (option: H13)	G4, F7 (option: H13)	G4, F7 (option: H13)	G4, F7 (option: H13)	G4, F7 (option: H13)
Connected air duct diameter [mm]	160	160	160	160	200	200
Weight [kg]	78	79	81	82	102	104
Heat recovery efficiency [%]*	73-87	73-87	72-87	72-87	80-87	80-87
Heat exchanger type	rotary	rotary	rotary	rotary	rotary	rotary
Heat exchanger material	aluminum	aluminum	aluminum	aluminum	aluminum	aluminum
SEC class	A	A	A	A	A	A
ErP	2016, 2018	2016, 2018	2016, 2018	2016, 2018	2016, 2018	2016, 2018

*Heat recovery efficiency is specified in compliance with EN 13141-7.

KOMFORT ROTO EC D2(E) 350

Sound power level, A-weighted	Total	Octave frequency band [Hz]								LpA 3 m	LpA 1 m
		63	125	250	500	1000	2000	4000	8000		
L _{WA} to supply inlet [dBA]	59	26	45	53	54	52	48	43	34		
L _{WA} to supply outlet [dBA]	83	44	58	67	75	75	79	75	71		
L _{WA} to exhaust inlet [dBA]	54	25	40	50	50	43	41	38	30		
L _{WA} to exhaust outlet [dBA]	74	42	52	63	70	63	68	66	62		
L _{WA} to environment [dBA]	53	18	35	46	49	48	43	37	33	33	43

Data provided for point 1 of the air flow diagram

Total power. Total sound pressure level.

Point	Total power of the unit [W]	Sound pressure level at 3 m (1 m) [dBA]
1	172	33 (43)
2	171	33 (43)
3	167	32 (42)
4	125	31 (41)
5	124	28 (38)
6	122	27 (37)
7	98	27 (37)
8	97	23 (33)
9	97	23 (33)

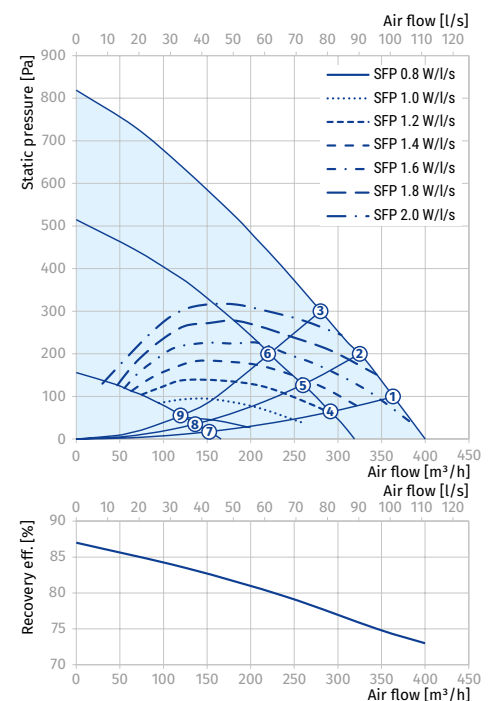

KOMFORT ROTO EC D(E) 350

Sound power level, A-weighted	Total	Octave frequency band [Hz]								LpA 3 m	LpA 1 m
		63	125	250	500	1000	2000	4000	8000		
LWA to supply inlet [dBA]	56	24	43	51	52	50	46	42	33		
LWA to supply outlet [dBA]	80	41	55	65	72	72	76	72	69		
LWA to exhaust inlet [dBA]	52	23	38	47	48	42	39	37	29		
LWA to exhaust outlet [dBA]	72	40	50	61	67	61	65	64	60		
LWA to environment [dBA]	51	16	33	44	47	46	41	36	32	31	41

Data provided for point 1 of the air flow diagram

Total power. Total sound pressure level.

Point	Total power of the unit [W]	Sound pressure level at 3 m (1m) [dBA]
1	154	31 (41)
2	151	31 (41)
3	149	30 (40)
4	116	27 (37)
5	116	26 (36)
6	115	26 (36)
7	76	24 (34)
8	75	21 (31)
9	63	21 (31)

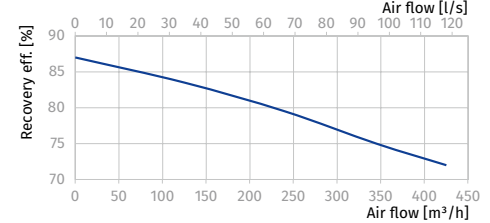
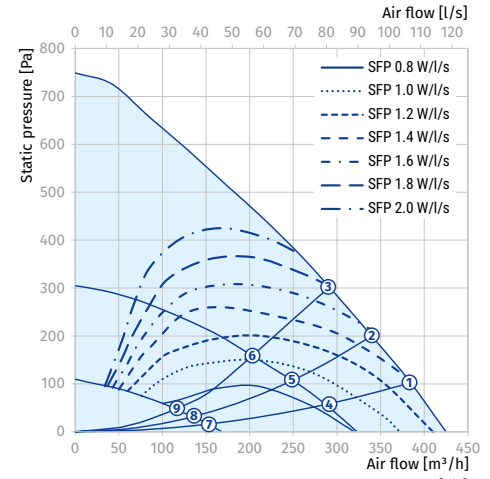

KOMFORT ROTO EC D(E) 650

Sound power level, A-weighted	Total	Octave frequency band [Hz]								LpA 3 m	LpA 1 m
		63	125	250	500	1000	2000	4000	8000		
LWA to supply inlet [dBA]	79	56	62	64	74	72	74	71	66		
LWA to supply outlet [dBA]	68	48	51	57	67	52	49	42	30		
LWA to exhaust inlet [dBA]	81	55	60	64	77	73	75	71	66		
LWA to exhaust outlet [dBA]	67	47	51	58	65	58	57	48	39		
LWA to environment [dBA]	57	30	46	45	55	46	47	39	38	36	46







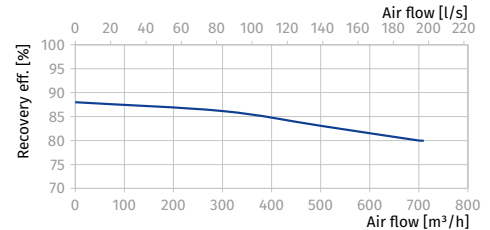
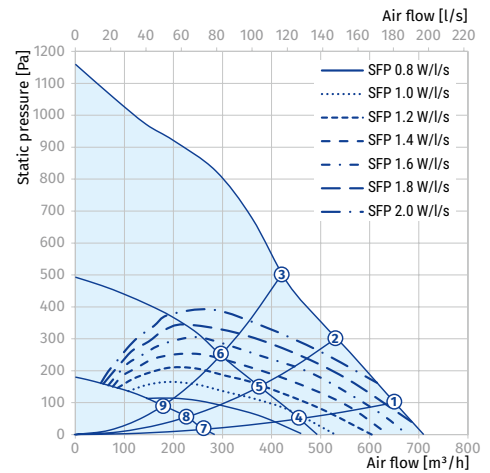









Data provided for point 1 of the air flow diagram

















Total power. Total sound pressure level.

Point	Total power of the unit [W]	Sound pressure level at 3 m (1m) [dBA]
1	342	36 (46)
2	342	36 (46)
3	342	35 (45)
4	122	31 (41)
5	122	29 (39)
6	122	29 (39)
7	34	27 (37)
8	33	24 (34)
9	33	24 (34)



Accessories

		KOMFORT Roto EC D2(E) 250 S21	KOMFORT Roto EC D(E) 250 S21	KOMFORT Roto EC D2(E) 350 S21
G4 panel filter		FP 280x180x48 G4	FP 260x220x48 G4	FP 372x180x48 G4
F7 panel filter		FP 280x180x48 F7	FP 260x220x48 F7	FP 372x180x48 F7
H13 panel filter		FP 280x180x48 H13	FP 260x220x48 H13	FP 372x180x48 H13
Control panel		S22	S22	S22
Wireless control panel		S22 Wi-Fi	S22 Wi-Fi	S22 Wi-Fi
LCD control panel		S25	S25	S25
VOC sensor		DPWQ30600	DPWQ30600	DPWQ30600
External CO ₂ sensor		DPWQ40200	DPWQ40200	DPWQ40200
Humidity sensor		DPWC11200	DPWC11200	DPWC11200
Humidity sensor		HR-S	HR-S	HR-S
Humidity sensor		FS2	FS2	FS2
Kitchen hood		DAH 251-13	DAH 251-13	DAH 251-13
Backdraft air damper		VRV 160	VRV 160	VRV 160
Air damper		VKA 160	VKA 160	VKA 160
Electric actuator		LF230	LF230	LF230
Electric actuator		TF230	TF230	TF230

		KOMFORT Roto EC D(E) 350 S21	KOMFORT Roto EC D(E) 650 S21
G4 panel filter		FP 320x235x48 G4	FP 378x295x48 G4
F7 panel filter		FP 320x235x48 F7	FP 378x295x48 F7
H13 panel filter		FP 320x235x48 H13	FP 378x295x48 H13
Control panel		S22	S22
Wireless control panel		S22 Wi-Fi	S22 Wi-Fi
LCD control panel		S25	S25
VOC sensor		DPWQ30600	DPWQ30600
External CO ₂ sensor		DPWQ40200	DPWQ40200
Humidity sensor		DPWC11200	DPWC11200
Humidity sensor		HR-S	HR-S
Humidity sensor		FS2	FS2
Kitchen hood		DAH 251-13	DAH 251-13
Backdraft air damper		VRV 160	VRV 200
Air damper		VKA 160	VKA 200
Electric actuator		LF230	LF230
Electric actuator		TF230	TF230

BLAUBOX E PRO

Supply ventilation units

Features

- Ventilation units for efficient supply ventilation in various premises.
- Controllable air supply, heating and filtration.
- Compatible with Ø 100 up to 315 mm round air ducts.



Air flow:
up to 1520 m³/h
422 l/s



Design

- The casing is made of double-skinned aluzinc panels, internally filled with mineral wool layer of 25 mm for heat and sound insulation.
- The mounting brackets with anti-vibration rubber mounts on the casing bottom ensure easy installation.
- The spigots for connection to the air ducts are located at the side of the unit and are rubber sealed for airtight connection to the air ducts.
- The hinged panel of the casing ensures easy access to the internals for cleaning, filter replacement and other maintenance operations.

Fans

- Asynchronous external rotor motor and centrifugal impeller with backward curved blades are used for air supply.
- Single- or three-phase motor modification depending on the fan model type.
- Integrated motor overheating protection with automatic restart.
- Dynamically balanced impeller.
- Equipped with ball bearings for longer service life.
- Reliable and quiet operation.

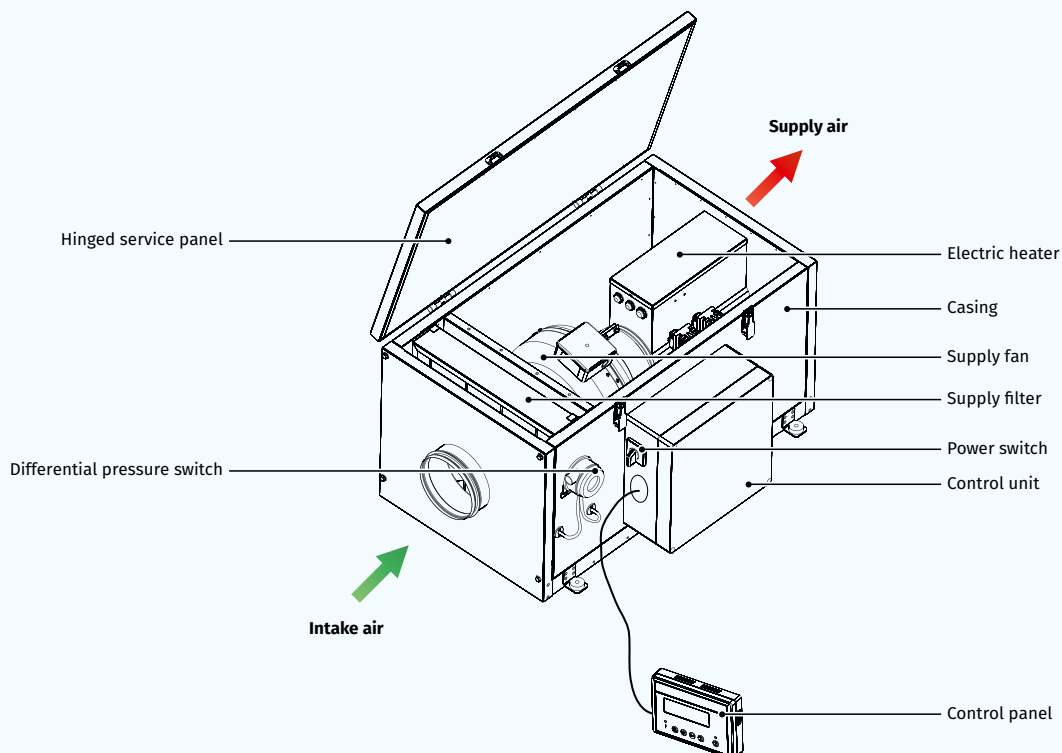

Air heater

- The unit is equipped with an electric heater for operation during cold seasons at low outside temperature.
- Two integrated overheat protection thermostats, one actuated at +60 °C with automatic restart and the other one actuated at +90 °C with manual restart.

Air filtration

- The built-in G4 supply filter provides air filtration.

Control and automation

- The unit incorporates an integrated control system with a wall-mounted control panel with LCD display.
- The standard delivery set includes a 10 m cable for connection of the unit and the control panel.
- **Control panel functions:**
 - Activating/deactivating the unit
 - Setting low, medium and high speeds for the supply fan as well as air flow control.
 - Setting and maintaining supply air temperature
 - Setting day- or week-scheduled

Automation functions:

- Filter clogging control with a differential pressure switch
- Overheating protection of the electric heating elements
- Disabling heater activation during the fan shutoff

Mounting

- The unit is suitable for indoor mounting on the floor, ceiling mounting or wall mounting with fixing brackets in any mounting position except for the vertical one with air flow downwards.
- The correct mounted unit must provide free access to the hinged panel for servicing and filter replacement.

Designation key

Series	Heater type	Rated air flow [m³/h]	Heater power [kW]	Control
BLAUBOX	E: electric heater	200; 300; 400; 800; 1000; 1200; 1500	1.8; 2.4; 3.4; 3.6; 5.1; 6; 9	Pro: with control panel

Overall dimensions [mm]

Model	∅ D	B	B1	H	L	L1
BLAUBOX E 200-1.8 Pro	99	382	421.5	408	800	647
BLAUBOX E 300-2.4 Pro	124	382	421.5	408	800	647
BLAUBOX E 400-2.4 Pro	149	455	496.5	438	800	647
BLAUBOX E 400-3.4 Pro	149	455	496.5	438	800	647
BLAUBOX E 400-5.1 Pro	149	455	496.5	438	800	647
BLAUBOX E 400-6 Pro	149	455	496.5	438	800	647
BLAUBOX E 800-3.4 Pro	199	487	526.5	513	835	684
BLAUBOX E 800-5.1 Pro	199	487	526.5	513	835	684
BLAUBOX E 800-6 Pro	199	487	526.5	513	835	684
BLAUBOX E 1000-3.6 Pro	249	487	526.5	513	835	684
BLAUBOX E 1000-6 Pro	249	487	526.5	513	835	684
BLAUBOX E 1000-9 Pro	249	487	526.5	513	835	684
BLAUBOX E 1200-6 Pro	314	527	566.5	548	900	750
BLAUBOX E 1200-9 Pro	314	527	566.5	548	900	750
BLAUBOX E 1500-6 Pro	314	527	566.5	548	900	750
BLAUBOX E 1500-9 Pro	314	527	566.5	548	900	750

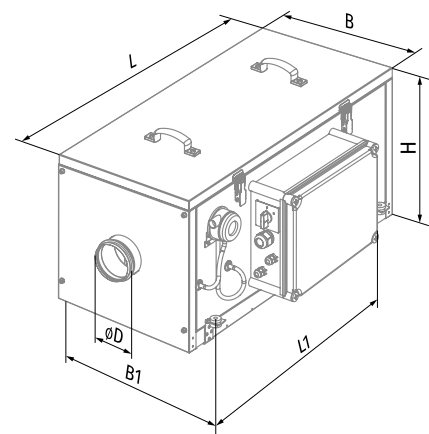

Technical data

Parameters	BLAUBOX E 200-1.8 Pro	BLAUBOX E 300-2.4 Pro	BLAUBOX E 400-2.4 Pro	BLAUBOX E 400-3.4 Pro	BLAUBOX E 400-5.1 Pro	BLAUBOX E 400-6 Pro
Voltage [V / 50 Hz]	1 ~ 230	1 ~ 230	1 ~ 230	1 ~ 230	3 ~ 400	3 ~ 400
Max. power without electric heater [kW]	0.073	0.075	0.098	0.098	0.098	0.098
Max. current without electric heater [A]	0.32	0.33	0.43	0.43	0.43	0.43
Max. power with electric heater [kW]	1.873	2.475	2.498	3.498	5.198	6.098
Max. current with electric heater [A]	8.12	10.73	10.83	15.23	7.83	9.13
Electric heater power [kW]	1.8	2.4	2.4	3.4	5.1	6.0
Electric heater current [A]	7.8	10.4	10.4	14.8	7.4	8.7
Number of electrical heating elements	3	3	2	2	3	3
Maximum air flow [m ³ /h (l/s)]	190 (53)	285 (79)	425 (118)	425 (118)	425 (118)	425 (118)
RPM [min ⁻¹]	2830	2800	2705	2705	2705	2705
Sound pressure level at 3 m [dBA]	27	28	29	29	29	29
Transported air temperature [°C]	-25...+40	-25...+40	-25...+40	-25...+40	-25...+40	-25...+40
Casing material	aluzinc	aluzinc	aluzinc	aluzinc	aluzinc	aluzinc
Insulation	25 mm mineral wool	25 mm mineral wool	25 mm mineral wool	25 mm mineral wool	25 mm mineral wool	25 mm mineral wool
Filter	G4	G4	G4	G4	G4	G4
Connected air duct diameter [mm]	100	125	150	150	150	150
Weight [kg]	50	50	50	50	50	50
SEC class	A	A	A	A	A	A
ErP	2016, 2018	2016, 2018	2016, 2018	2016, 2018	2016, 2018	2016, 2018

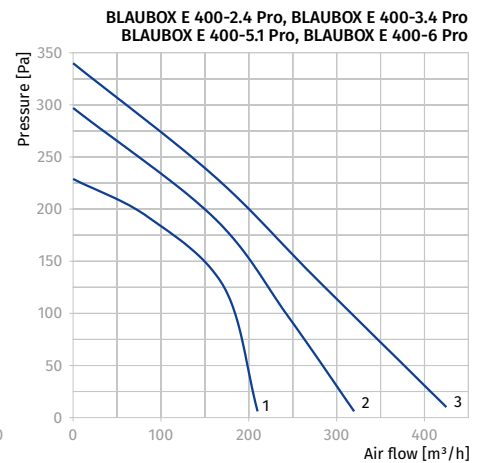
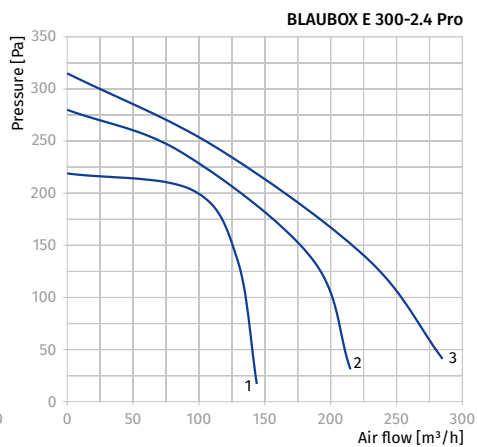
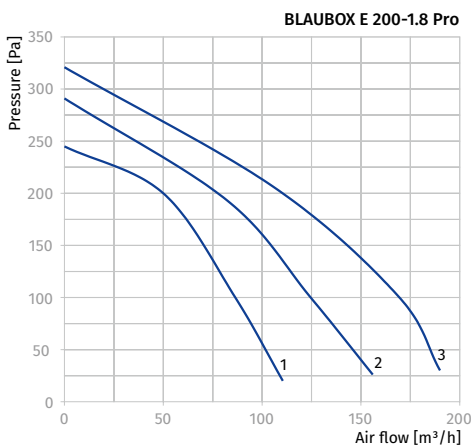



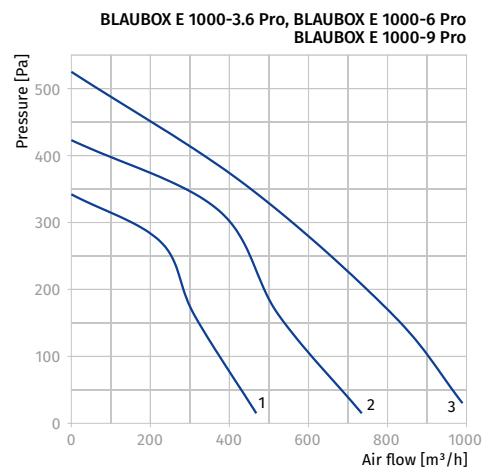
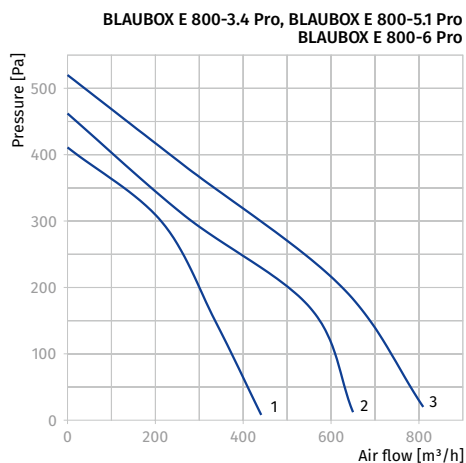



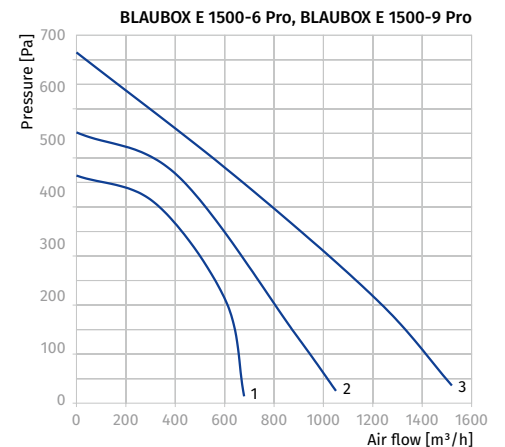
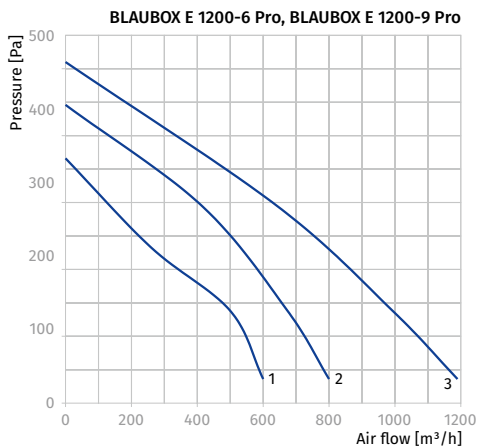

Parameters	BLAUBOX E 800-3.4 Pro	BLAUBOX E 800-5.1 Pro	BLAUBOX E 800-6 Pro	BLAUBOX 1000-3.6 Pro	BLAUBOX E 1000-6 Pro	BLAUBOX E 1000-9 Pro
Voltage [V / 50 Hz]	1 ~ 230	3 ~ 400	3 ~ 400	3 ~ 400	3 ~ 400	3 ~ 400
Max. power without electric heater [kW]	0.193	0.193	0.193	0.194	0.194	0.194
Max. current without electric heater [A]	0.84	0.84	0.84	0.84	0.84	0.84
Max. power with electric heater [kW]	3.593	5.293	6.193	3.794	6.194	9.194
Max. current with electric heater [A]	15.64	8.24	9.54	6.15	9.55	13.85
Electric heater power [kW]	3.4	5.1	6.0	3.6	6.0	9.0
Electric heater current [A]	14.8	7.4	8.7	5.3	8.7	13.0
Number of electrical heating elements	2	3	3	3	3	3
Maximum air flow [m³/h (l/s)]	810 (225)	810 (225)	810 (225)	990 (275)	990 (275)	990 (275)
RPM [min ⁻¹]	2780	2780	2780	2780	2780	2780
Sound pressure level at 3 m [dBA]	30	30	30	30	30	30
Transported air temperature [°C]	-25...+40	-25...+40	-25...+40	-25...+40	-25...+40	-25...+40
Casing material	aluzinc	aluzinc	aluzinc	aluzinc	aluzinc	aluzinc
Insulation	25 mm mineral wool	25 mm mineral wool	25 mm mineral wool	25 mm mineral wool	25 mm mineral wool	25 mm mineral wool
Filter	G4	G4	G4	G4	G4	G4
Connected air duct diameter [mm]	200	200	200	250	250	250
Weight [kg]	52	52	52	52	52	52
SEC class	C	C	C	C	C	C
ErP	2016, 2018	2016, 2018	2016, 2018	2016, 2018	2016, 2018	2016, 2018



Parameters	BLAUBOX E 1200-6 Pro	BLAUBOX E 1200-9 Pro	BLAUBOX E 1500-6 Pro	BLAUBOX E 1500-9 Pro
Voltage [V / 50 Hz]	3 ~ 400	3 ~ 400	3 ~ 400	3 ~ 400
Max. power without electric heater [kW]	0.171	0.171	0.296	0.296
Max. current without electric heater [A]	0.77	0.77	1.34	1.34
Max. power with electric heater [kW]	6.171	9.171	6.296	9.296
Max. current with electric heater [A]	9.47	13.77	10.04	14.34
Electric heater power [kW]	6.0	9.0	6.0	9.0
Electric heater current [A]	8.7	13.0	8.7	13.0
Number of electrical heating elements	3	3	3	3
Maximum air flow [m ³ /h (l/s)]	1190 (331)	1190 (331)	1520 (422)	1520 (422)
RPM [min ⁻¹]	2600	2600	2720	2720
Sound pressure level at 3 m [dBA]	30	30	30	30
Transported air temperature [°C]	-25...+40	-25...+40	-25...+40	-25...+40
Casing material	aluzinc	aluzinc	aluzinc	aluzinc
Insulation	25 mm mineral wool	25 mm mineral wool	25 mm mineral wool	25 mm mineral wool
Filter	G4	G4	G4	G4
Connected air duct diameter [mm]	315	315	315	315
Weight [kg]	62	62	62	62
ErP	2016, 2018	2016, 2018	2016, 2018	2016, 2018



Accessories

		BLAUBOX E 200 Pro	BLAUBOX E 300 Pro	BLAUBOX E 400 Pro	BLAUBOX E 800 Pro	BLAUBOX E 1000 Pro	BLAUBOX E 1200 Pro	BLAUBOX E 1500 Pro
G4 panel filter		FP 335x322x70 G4	FP 335x322x70 G4	FP 397x364x70 G4	FP 439x428x70 G4	FP 439x428x70 G4	FP 475x470x70 G4	FP 475x470x70 G4
Silencer		SD 100	SD 125	SD 150	SD 200	SD 250	SD 315	SD 315
Silencer		SDF 100	SDF 125	SDF 150	SDF 200	SDF 250	SDF 315	SDF 315
Flexible anti-vibration connector		EVA 100	EVA 125	EVA 150	EVA 200	EVA 250	EVA 315	EVA 315
Clamp		KZ 100	KZ 125	KZ 150	KZ 200	KZ 250	KZ 315	KZ 315
Backdraft air damper		VRV 100	VRV 125	VRV 150	VRV 200	VRV 250	VRV 315	VRV 315
Air damper		VKA 100	VKA 125	VKA 150	VKA 200	VKA 250	VKA 315	VKA 315
Air damper electric actuator		LF230	LF230	LF230	LF230	LF230	LF230	LF230
Air damper electric actuator		TF230	TF230	TF230	TF230	TF230	TF230	TF230

SUPPLY VENTILATION UNITS

BLAUBOX ME PRO

Supply ventilation units

Features

- Ventilation units for efficient supply ventilation in various premises.
- Controllable air supply, heating and filtration.
- Compatible with 400x200 up to 600x350 mm rectangular air ducts.



Air flow:
up to 3500 m³/h
972 l/s



Design

- The casing is made of double-skinned aluzinc panels, internally filled with mineral wool layer of 25 mm for heat- and sound-insulation.
- The mounting brackets with anti-vibration rubber mounts on the casing bottom ensure easy installation.
- The hinged panel of the casing ensures easy access to the internals for cleaning, filter replacement and other maintenance operations.

Fans

- Asynchronous external rotor motor and centrifugal double-inlet impeller with forward curved blades is used for air supply.
- Single- or three-phase motor modification depending on the fan model type.
- Integrated motor overheating protection with automatic restart.
- Dynamically balanced impeller.
- Equipped with ball bearings for longer service life.
- Reliable and quiet operation.

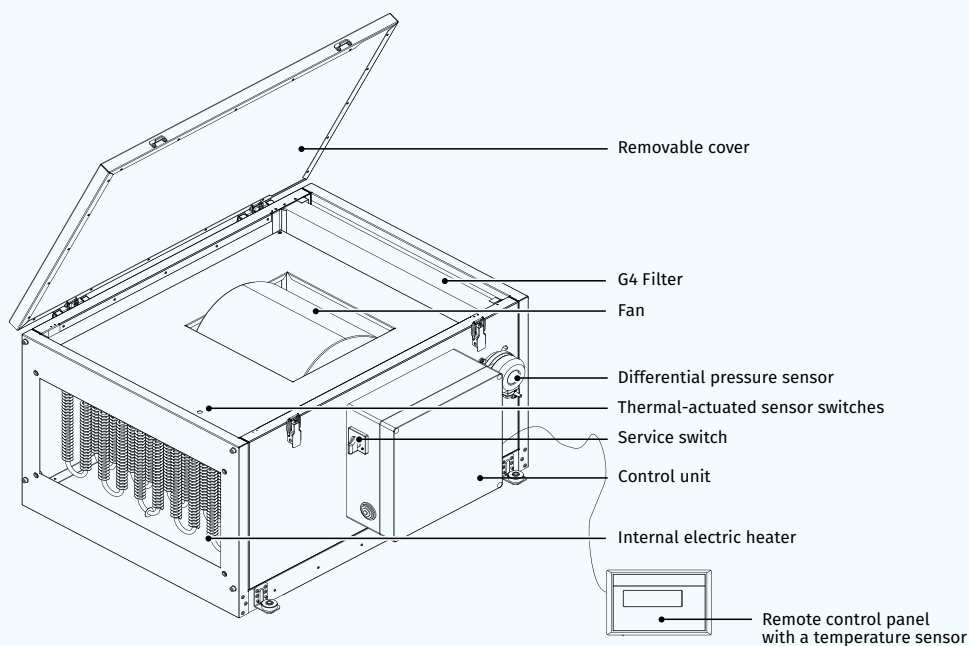

Air heater

- The unit is equipped with an electric heater for operation during cold seasons at low outside temperature.
- The heating elements are extra ribbed for larger heat exchange surface.
- Two integrated overheat protection thermostats, one actuated at +60 °C with automatic restart and the other one actuated at +90 °C with manual restart.

Air filtration

- The built-in G4 supply filter provides air filtration.

Control and automation

- The unit incorporates an integrated control system with a wall-mounted control panel and LCD display.
- The standard delivery set includes a 10 m cable for connection of the unit and the control panel.

Control panel functions:

- Activating/deactivating the unit.
- Setting low, medium and high speeds for the supply fan as well as air flow control.
- Setting and maintaining supply air temperature.
- Setting or week-scheduled operation of the unit.

Automation functions:

- Filter clogging control with a differential pressure switch.
- Overheating protection of the electric heating elements.
- Disabling heater activation during the fan shutoff.

Mounting

- The unit is suitable for indoor mounting on the floor, ceiling mounting or wall mounting with fixing brackets in any mounting position except for the vertical one with air flow downwards.
- The correct mounted unit must provide free access to the hinged panel for servicing and filter replacement.

Designation key

Series	Casing modification	Heater type	Rated air flow [m³/h]	Electric heater power [kW]	Control
BLAUBOX	M: single-block unit	E: electric heater	800; 1200; 2000; 2500; 3200; 3500	3.3; 9.9; 18; 25.2	Pro: with control panel

Overall dimensions [mm]

Model	B	B1	B2	H	L	L1
BLAUBOX ME 800-3.3 Pro	500	400	549	352	650	530
BLAUBOX ME 1200-9.9 Pro	500	400	549	352	650	530
BLAUBOX ME 2000-18 Pro	600	500	649	480	800	680
BLAUBOX ME 2500-18 Pro	600	500	649	480	800	680
BLAUBOX ME 3200-25.2 Pro	710	600	759	530	1000	880
BLAUBOX ME 3500-25.2 Pro	710	600	759	530	1000	880

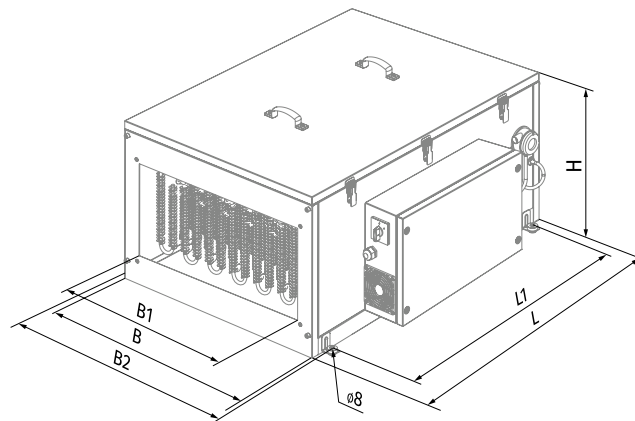

Technical data

Parameters	BLAUBOX ME 800-3.3 Pro	BLAUBOX ME 1200-9.9 Pro	BLAUBOX ME 2000-18 Pro
Voltage [V / 50 Hz]	1 ~ 230	3 ~ 400	3 ~ 400
Max. power without electric heater [kW]	0.245	0.410	0.49
Max. current without electric heater [A]	1.08	1.8	2.15
Max. power with electric heater [kW]	3.55	9.94	18.49
Max. current with electric heater [A]	15.38	16.1	28.15
Electric heater power [kW]	3.3	9.9	18.0
Electric heater current [A]	14.3	14.3	26.0
Maximum air flow [m ³ /h (l/s)]	800 (222)	1200 (333)	2000 (556)
RPM [min ⁻¹]	1650	1850	1100
Sound pressure level at 3 m [dBA]	35	38	40
Transported air temperature [°C]	-25...+40	-25...+40	-25...+40
Casing material	aluzinc	aluzinc	aluzinc
Insulation	25 mm mineral wool	25 mm mineral wool	25 mm mineral wool
Filter	G4	G4	G4
Connected air duct size [mm]	400x200	400x200	500x250
Weight [kg]	36.2	38.9	61.5
SEC class	D	-	-
ErP	2016, 2018	2016, 2018	2016, 2018

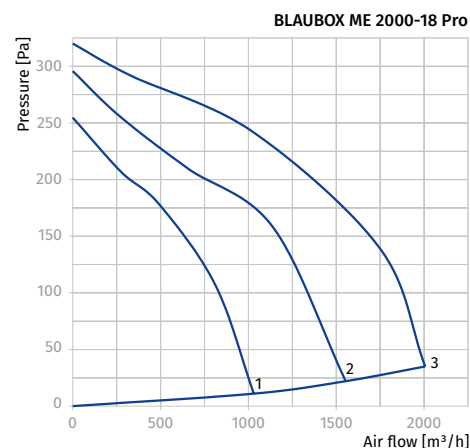
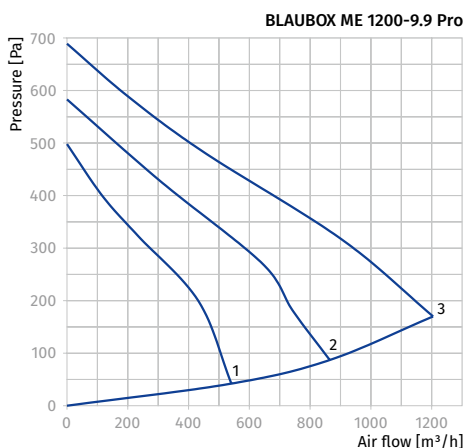
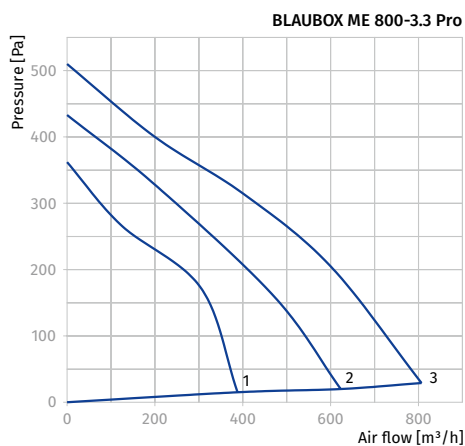

Parameters	BLAUBOX ME 2500-18 Pro	BLAUBOX ME 3200-25.2 Pro	BLAUBOX ME 3500-25.2 Pro
Voltage [V / 50 Hz]	3 ~ 400	3 ~ 400Y	3 ~ 400Y
Max. power without electric heater [kW]	0.65	1.27	1.27
Max. current without electric heater [A]	2.84	2.3	2.3
Max. power with electric heater [kW]	18.65	26.47	26.47
Max. current with electric heater [A]	28.84	38.7	38.7
Electric heater power [kW]	18.0	25.2	25.2
Electric heater current [A]	26.0	36.4	36.4
Maximum air flow [m³/h (l/s)]	2500 (695)	3200 (889)	3500 (972)
RPM [min ⁻¹]	1000	1200	1200
Sound pressure level at 3 m [dBA]	45	53	53
Transported air temperature [°C]	-25...+40	-25...+40	-25...+40
Casing material	aluzinc	aluzinc	aluzinc
Insulation	25 mm mineral wool	25 mm mineral wool	25 mm mineral wool
Filter	G4	G4	G4
Connected air duct size [mm]	500x300	600x300	600x350
Weight [kg]	62	69.4	69.3
SEC class	-	-	-
ErP	2016, 2018	2016, 2018	2016, 2018

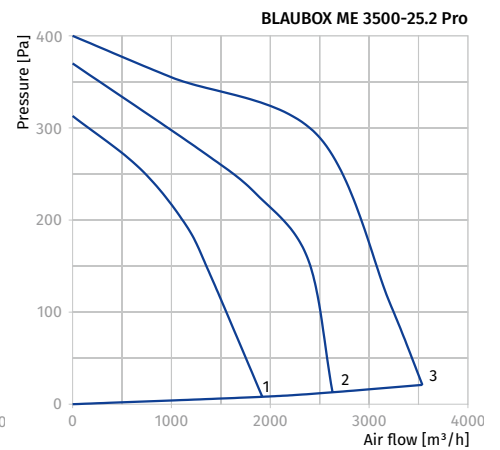
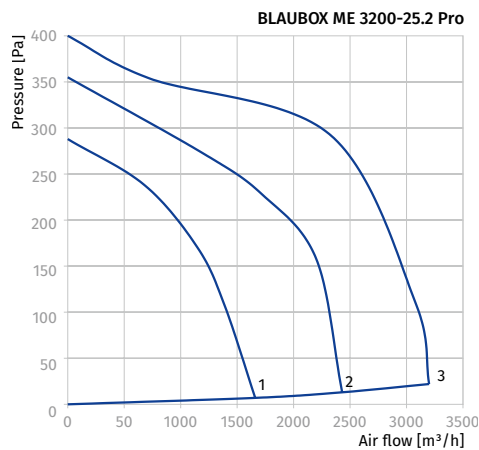
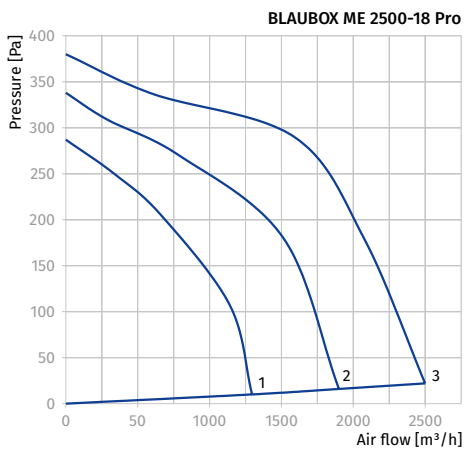

Accessories

		BLAUBOX ME 800-3.3 Pro	BLAUBOX ME 1200-9.9 Pro	BLAUBOX ME 2000-18 Pro	BLAUBOX ME 2500-18 Pro	BLAUBOX ME 3200-25.2 Pro	BLAUBOX ME 3500-25.2 Pro
G4 panel filter		FP 442x275x47 G4	FP 442x275x47 G4	FP 545x390x47 G4	FP 545x390x47 G4	FP 653x440x47 G4	FP 653x440x47 G4
Silencer		SD 40x20	SD 40x20	SD 50x25	SD 50x30	SD 60x30	SD 60x35
Duct cooling unit		KFK 40x20-3	KFK 40x20-3	KFK 50x25-3	KFK 50x30-3	KFK 60x30-3	KFK 60x35-3
Air flow dampers		SL 40x20	SL 40x20	SL 50x25	SL 50x30	SL 60x30	SL 60x35
Flexible anti-vibration connector		EVA 40x20	EVA 40x20	EVA 50x25	EVA 50x30	EVA 60x30	EVA 60x35
Air damper electric actuator		LF230	LF230	LF230	LF230	LF230	LF230
Air damper electric actuator		TF230	TF230	TF230	TF230	TF230	TF230

BLAUBOX MW PRO

Supply ventilation units

Features

- Ventilation units for efficient supply ventilation in various premises.
- Controllable air supply, heating and filtration.
- Compatible with 400x200 up to 800x500 mm rectangular air ducts.



Air flow:
up to 6500 m³/h
1806 l/s



Design

- The casing is made of double-skinned aluzinc panels, internally filled with 25 mm mineral wool layer for heat and sound insulation.
- The casing has fixing brackets with vibration absorbing connectors for easy installation.
- The hinged casing side panel ensures easy access to the internals for cleaning, filter replacement and other maintenance operations.

Fans

- Asynchronous external rotor motor and centrifugal double-intake impeller with forward curved blades is used for air supply.
- Single- or three-phase motor modification depending on the fan model type.
- Integrated motor overheating protection with automatic restart.
- Dynamically balanced impeller.
- Equipped with ball bearings for longer service life.
- Reliable and quiet operation.

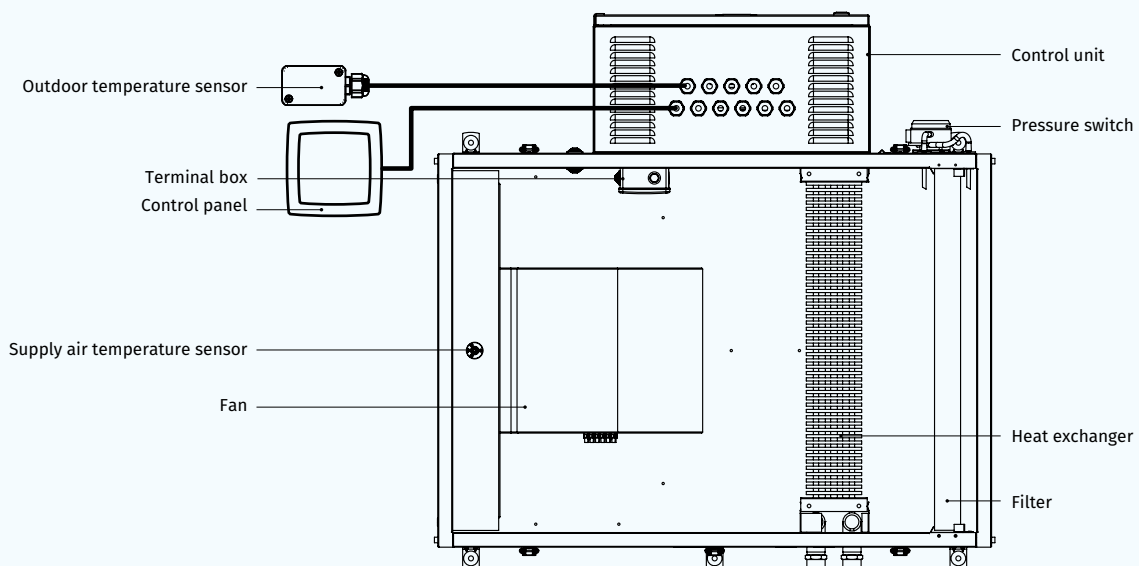

Air heater

- The units are equipped with a water (glycol) heater for operation during cold seasons at low outside temperature.
- The air temperature sensor downstream of the water heater and the return heat medium sensor ensure freezing protection of the water heater. If any of these sensors detects a temperature point below the set minimum value, the signal is sent automatically to the control unit to troubleshoot cooling.

Air filtration

- The built-in G4 supply filter provides air filtration.

Control and automation

- The units incorporate an integrated control system with a wall-mounted control panel and LCD display.
- The standard delivery set includes a 10 m cable for connection of the unit and the control panel.
- **Control panel functions:**
 - Activating/deactivating the unit.
 - Setting low, medium and high speeds for the supply fan. Air flow control.
 - The models with a water mixing unit have the function of setting and maintaining the supply air temperature by means of controlling the heat medium control valve.

Automation functions:

- Supply air temperature control by means of controlling the heat medium control valve.
- Control of the supply air damper actuator (separate order).
- Control of the external circulation pump on the heat medium feed line.
- Regulation of heat medium flow in the water heater in case of the differential pressure of the return heat medium below 40 kPa.
- Water heater freezing protection with the mixing unit and the circulation pump.
- Control of the cooler with respect to the set indoor air temperature (separate order).
- Supply fan control.
- Supply filter clogging control.
- Shutdown of the unit on signal from the fire alarm panel.

Mounting

- The unit is suitable for mounting on the floor, ceiling mounting or wall mounting with fixing brackets in any mounting position except for the vertical one with air flow downwards.
- The correct mounted unit must provide free access to the hinged panel for servicing and filter replacement.

Designation key

Series	Casing modification	Heater type	Rated air flow [m³/h]	Number of water coil rows	Control
BLAUBOX	M: single-block unit	W: water heater	750; 1200; 1800; 2100; 3000; 3200; 6500	– 4	Pro: with control panel

Overall dimensions [mm]

Model	B3	B	B2	H1	H	L
BLAUBOX MW 750-4 Pro	400	500	674	200	352	650
BLAUBOX MW 1200-4 Pro	400	500	674	200	352	650
BLAUBOX MW 1800-4 Pro	500	600	775	250	480	800
BLAUBOX MW 2100-4 Pro	500	600	775	300	480	800
BLAUBOX MW 3000-4 Pro	600	710	1000	300	530	1000
BLAUBOX MW 3200-4 Pro	600	710	1000	350	530	1000
BLAUBOX MW 6500-4 Pro	800	925	1212	500	670	1299

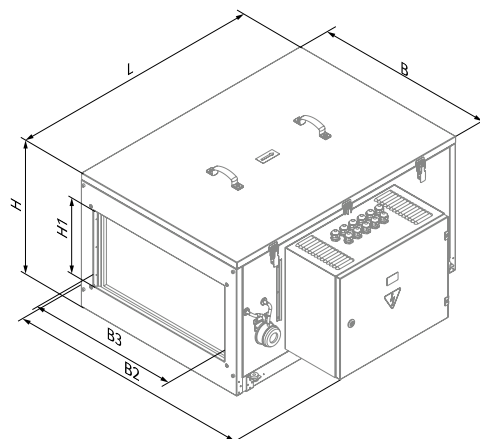

Technical data

Parameters	BLAUBOX MW 750-4 Pro	BLAUBOX MW 1200-4 Pro	BLAUBOX MW 1800-4 Pro	BLAUBOX MW 2100-4 Pro
Voltage [V / 50 Hz]	1 ~ 230	1 ~ 230	1 ~ 230	1 ~ 230
Number of water (glycol) coil rows	4	4	4	4
Power [kW]	0.245	0.410	0.490	0.650
Current [A]	1.08	1.8	2.15	2.84
Maximum air flow [m ³ /h (l/s)]	750 (208)	1200 (333)	1870 (519)	2150 (597)
RPM [min ⁻¹]	1650	1850	1100	1000
Sound pressure level at 3 m [dBA]	35	38	40	45
Transported air temperature [°C]	-25...+40	-25...+40	-25...+40	-25...+40
Casing material	aluzinc	aluzinc	aluzinc	aluzinc
Insulation	25 mm mineral wool	25 mm mineral wool	25 mm mineral wool	25 mm mineral wool
Supply filter	G4	G4	G4	G4
Connected air duct diameter [mm]	400x200	400x200	500x250	500x300
Weight [kg]	41.3	42.8	62.5	63
SEC class	D	-	-	-
ErP	2016, 2018	2016, 2018	2016, 2018	2016, 2018

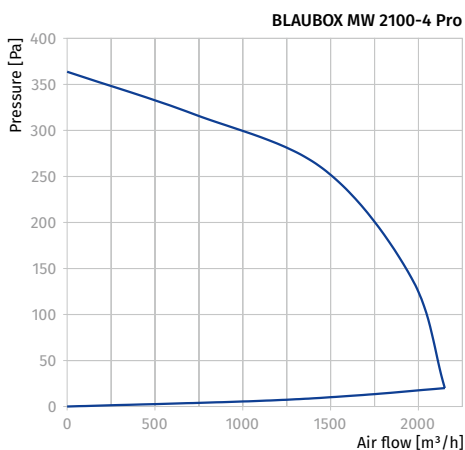
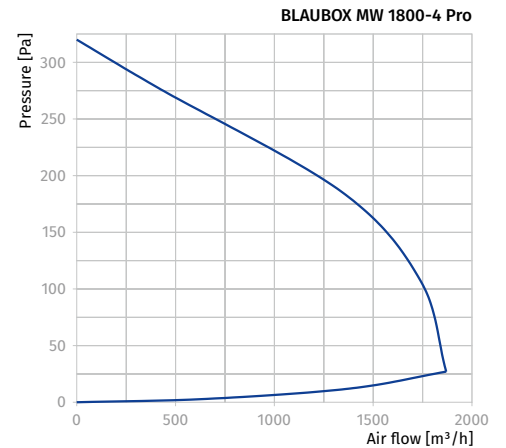
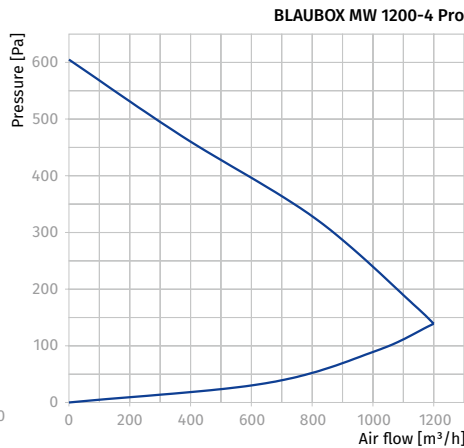
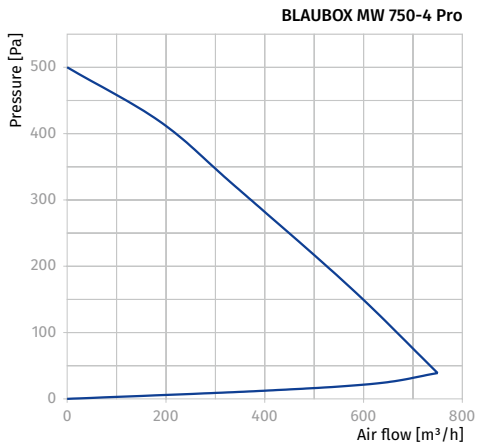

Parameters	BLAUBOX MW 3000-4 Pro	BLAUBOX MW 3200-4 Pro	BLAUBOX MW 6500-4 Pro
Voltage [V / 50 Hz]	3 ~ 400Y	3 ~ 400Y	3 ~ 400
Number of water (glycol) coil rows	4	4	4
Power [kW]	1.27	1.27	1.80
Current [A]	2.3	2.3	4.5
Maximum air flow [m³/h (l/s)]	3000 (833)	3250 (903)	6500 (1806)
RPM [min ⁻¹]	1200	1200	1400
Sound pressure level at 3 m [dBA]	53	53	55
Transported air temperature [°C]	-40...+45	-40...+45	-25...+40
Casing material	aluzinc	aluzinc	aluzinc
Insulation	25 mm mineral wool	25 mm mineral wool	25 mm mineral wool
Supply filter	G4	G4	G4
Connected air duct diameter [mm]	600x300	600x350	800x500
Weight [kg]	73.2	73.1	136
SEC class	-	-	-
ErP	2016, 2018	2016, 2018	2016, 2018

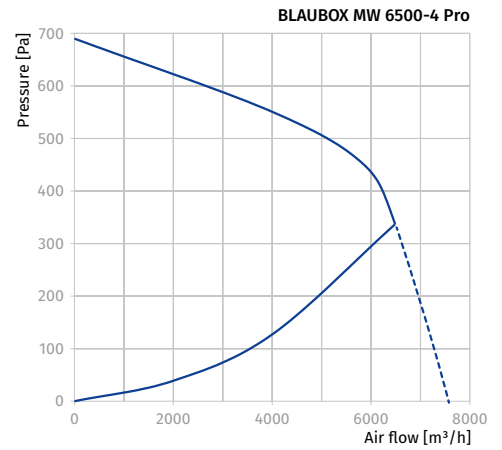
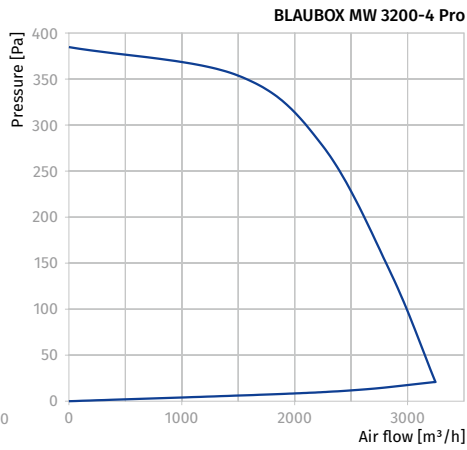
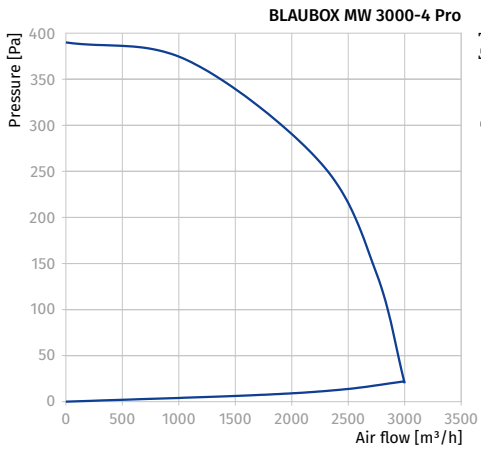

Hot water coil calculation diagram

BLAUBOX MW 750-4 PRO / BLAUBOX MW 1200-4 PRO

Air temperature downstream of the water heating coils [°C]

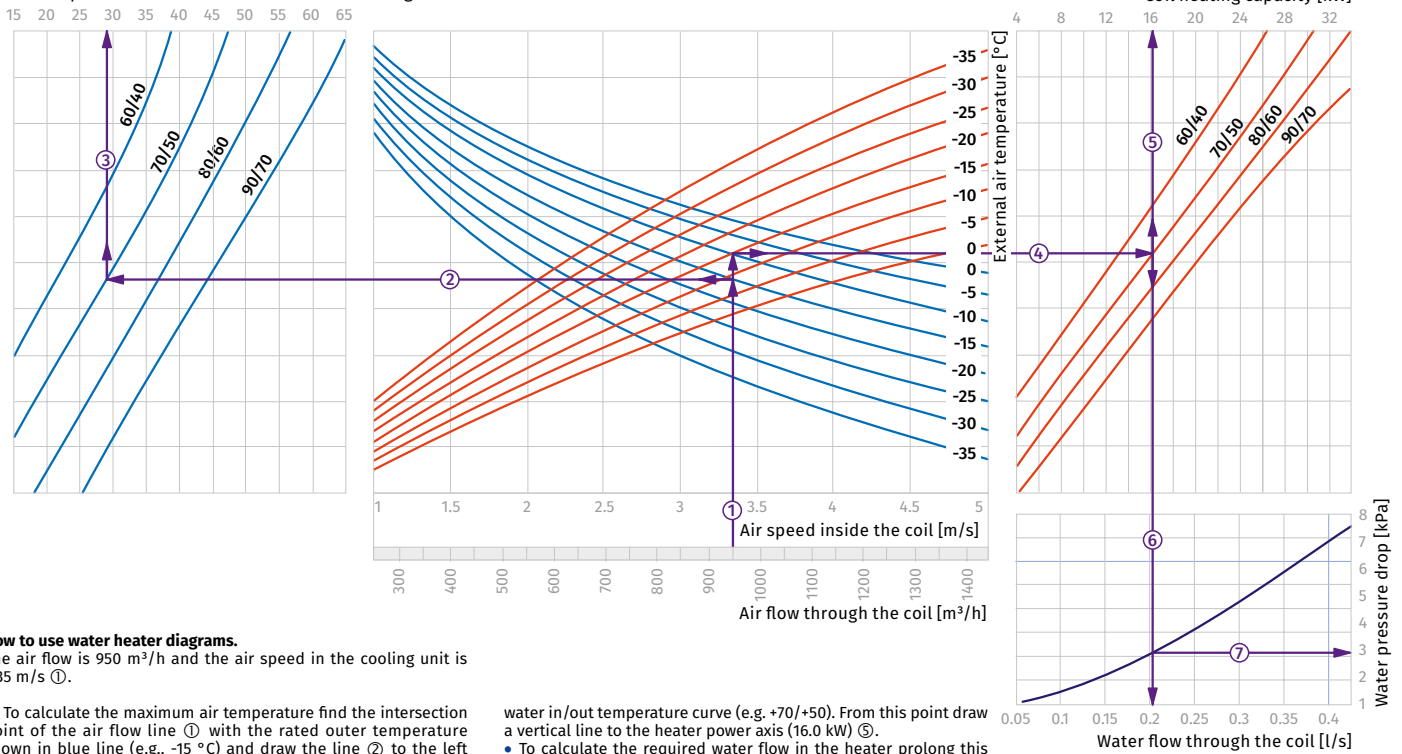

How to use water heater diagrams.

The air flow is 950 m³/h and the air speed in the cooling unit is 3.35 m/s ①.

- To calculate the maximum air temperature find the intersection point of the air flow line ① with the rated outer temperature shown in blue line (e.g., -15 °C) and draw the line ② to the left until it crosses the water in/out temperature curve (e.g. +70/+50). From this point draw a vertical line to the supply air temperature downstream of the heater (+29 °C) ③.
- To calculate the heater power find the intersection point of the air flow ① with the rated winter temperature shown in red line (e.g., -15 °C) and draw the line ④ to the right until it crosses the

water in/out temperature curve (e.g. +70/+50). From this point draw a vertical line to the heater power axis (16.0 kW) ⑤.

- To calculate the required water flow in the heater prolong this line ⑥ downwards to the water flow axis (0.2 l/s).
- To calculate the water pressure drop in the heater find the intersection point of the line ⑥ with the pressure loss curve and prolong the line ⑦ to the right on the water pressure drop axis (2.1 kPa).

BLAUBOX MW 1800-4 PRO / BLAUBOX MW 2100-4 PRO

Air temperature downstream of the water heating coils [°C]

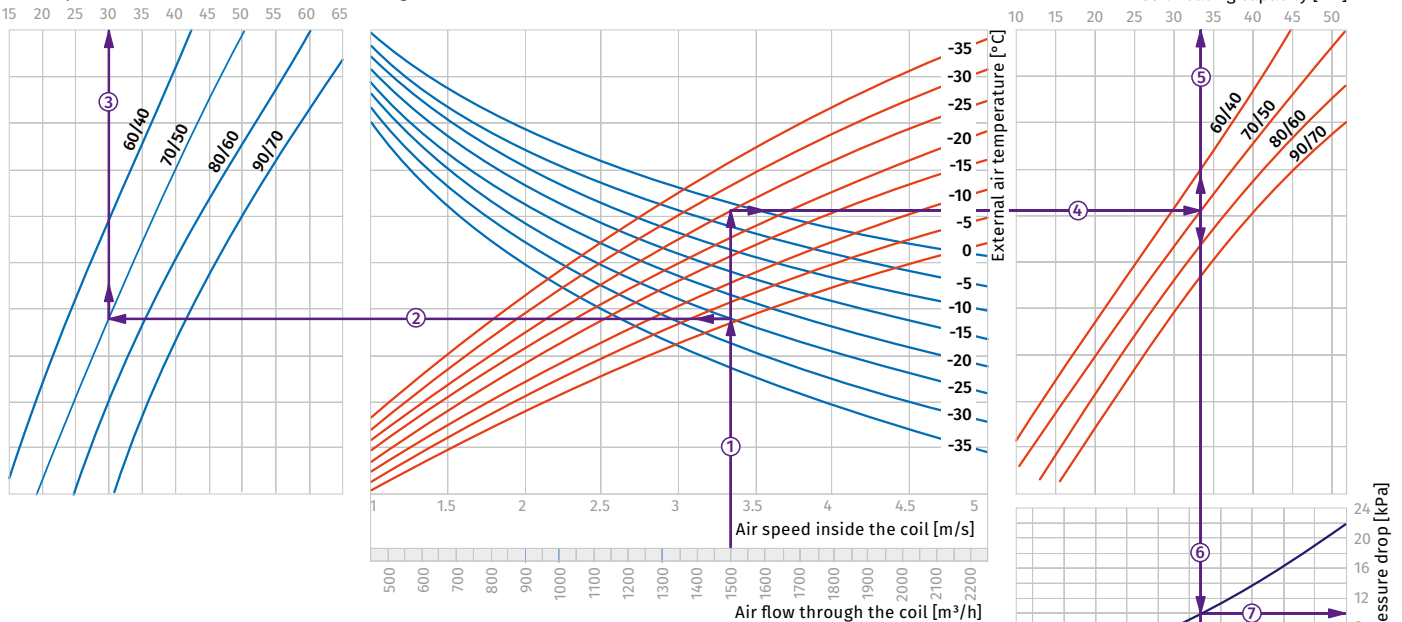

How to use water heater diagrams.

The air flow is 1500 m³/h and the air speed in the cooling unit is 3.5 m/s ①.

- To calculate the maximum air temperature find the intersection point of the air flow line ① with the rated outer temperature shown in blue line (e.g., -25 °C) and draw the line ② to the left until it crosses the water in/out temperature curve (e.g. +70/+50). From this point draw a vertical line to the supply air temperature downstream of the heater (+30 °C) ③.
- To calculate the heater power find the intersection point of the air flow ① with the rated winter temperature shown in red line (e.g., -25 °C) and draw the line ④ to the right until it crosses the

water in/out temperature curve (e.g. +70/+50). From this point draw a vertical line to the heater power axis (33.0 kW) ⑤.

- To calculate the required water flow in the heater prolong this line ⑥ downwards to the water flow axis (0.42 l/s).
- To calculate the water pressure drop in the heater find the intersection point of the line ⑥ with the pressure loss curve and prolong the line ⑦ to the right on the water pressure drop axis (10.0 kPa).

BLAUBOX MW 3000-4 PRO / BLAUBOX MW 3200-4 PRO

Air temperature downstream of the water heating coils [°C]

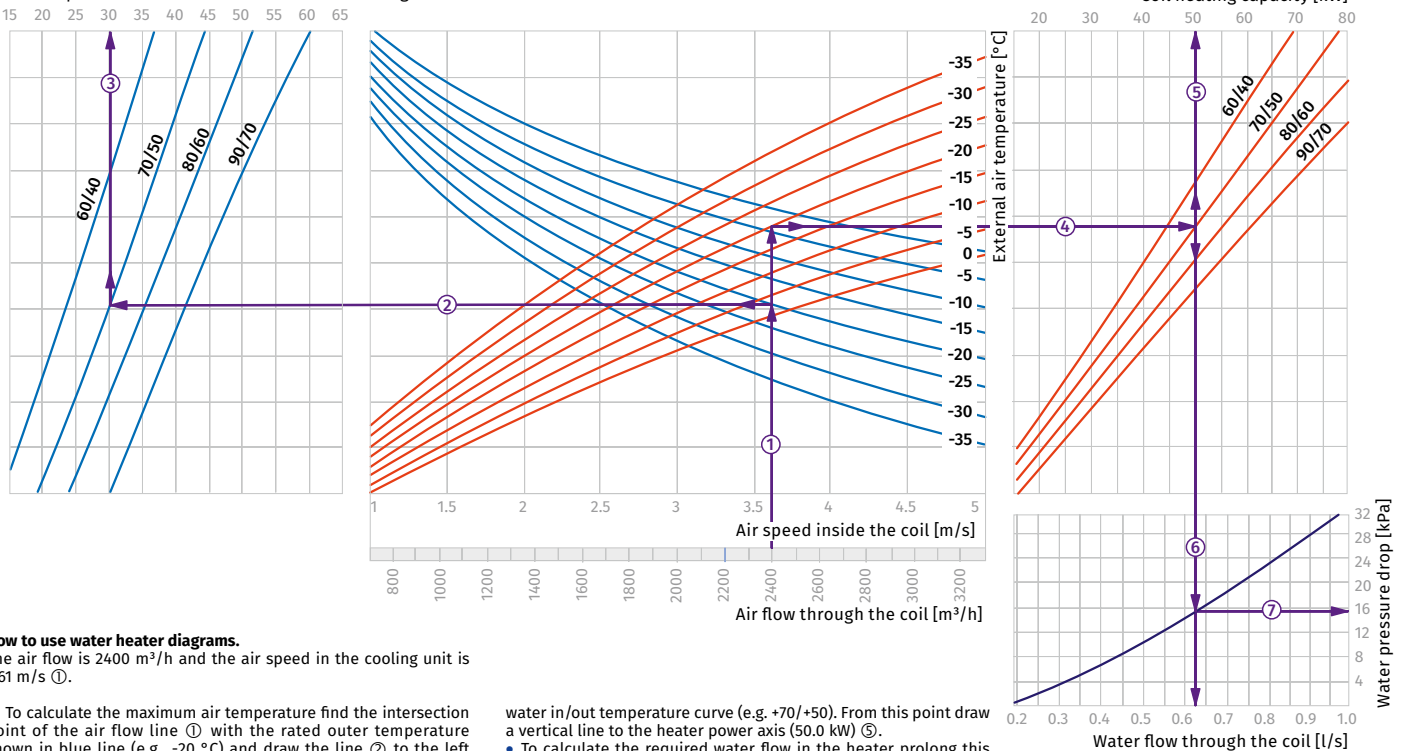

How to use water heater diagrams.

The air flow is 2400 m³/h and the air speed in the cooling unit is 3.61 m/s ①.

- To calculate the maximum air temperature find the intersection point of the air flow line ① with the rated outer temperature shown in blue line (e.g., -20 °C) and draw the line ② to the left until it crosses the water in/out temperature curve (e.g. +70/+50). From this point draw a vertical line to the supply air temperature downstream of the heater (+30 °C) ③.
- To calculate the heater power find the intersection point of the air flow ① with the rated winter temperature shown in red line (e.g., -20 °C) and draw the line ④ to the right until it crosses the

- water in/out temperature curve (e.g. +70/+50). From this point draw a vertical line to the heater power axis (50.0 kW) ⑤.
- To calculate the required water flow in the heater prolong this line ⑥ downwards to the water flow axis (0.62 l/s).
- To calculate the water pressure drop in the heater find the intersection point of the line ⑥ with the pressure loss curve and prolong the line ⑦ to the right on the water pressure drop axis (15.0 kPa).

BLAUBOX MW 6500-4 PRO

Air temperature downstream of the water heating coils [°C]

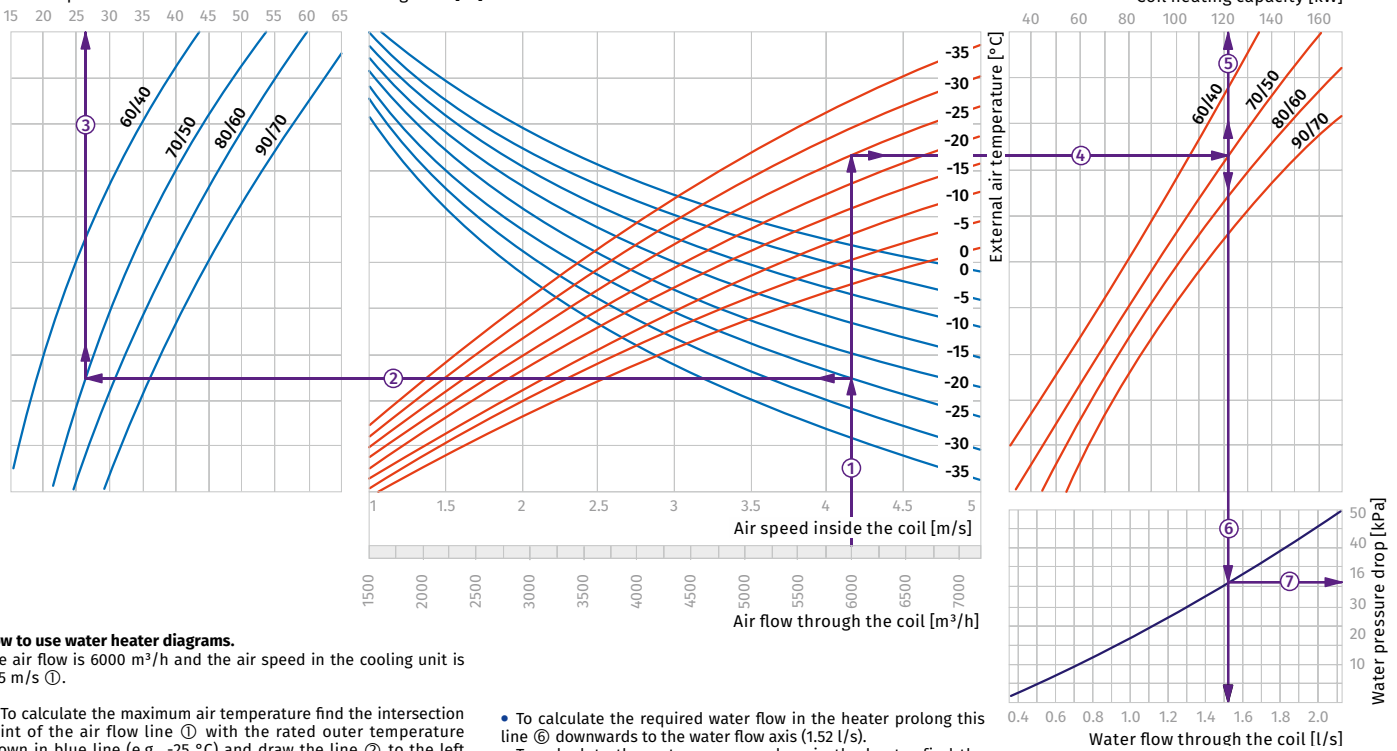











How to use water heater diagrams.











The air flow is 6000 m³/h and the air speed in the cooling unit is 4.15 m/s ①.

- To calculate the maximum air temperature find the intersection point of the air flow line ① with the rated outer temperature shown in blue line (e.g., -25 °C) and draw the line ② to the left until it crosses the water in/out temperature curve (e.g. +70/+50). From this point draw a vertical line to the supply air temperature downstream of the heater (+27 °C) ③.
- To calculate the heater power find the intersection point of the air flow ① with the rated winter temperature shown in red line (e.g., -25 °C) and draw the line ④ to the right until it crosses the water in/out temperature curve (e.g. +70/+50). From this point draw a vertical line to the heater power axis (121.0 kW) ⑤.

- To calculate the required water flow in the heater prolong this line ⑥ downwards to the water flow axis (1.52 l/s).
- To calculate the water pressure drop in the heater find the intersection point of the line ⑥ with the pressure loss curve and prolong the line ⑦ to the right on the water pressure drop axis (31.0 kPa).

Accessories

		BLAUBOX MW 750-4 Pro	BLAUBOX MW 1200-4 Pro	BLAUBOX MW 1800-4 Pro	BLAUBOX MW 2100-4 Pro
G4 panel filter		FP 442x275x47 G4	FP 442x275x47 G4	FP 545x390x47 G4	FP 545x390x47 G4
G4 pocket filter		-	-	-	-
Silencer		SD 40x20	SD 40x20	SD 50x25	SD 50x30
Duct cooling unit		KFK 40x20-3	KFK 40x20-3	KFK 50x25-3	KFK 50x30-3
Duct cooling unit		KWK 40x20-3	KWK 40x20-3	KWK 50x25-3	KWK 50x30-3
Water mixing unit		WMG	WMG	WMG	WMG
Air flow dampers		SL 40x20	SL 40x20	SL 50x25	SL 50x30
Flexible anti-vibration connector		EVA 40x20	EVA 40x20	EVA 50x25	EVA 50x30
Air damper electric actuator		LF230	LF230	LF230	LF230
Air damper electric actuator		TF230	TF230	TF230	TF230

		BLAUBOX MW 3000-4 Pro	BLAUBOX MW 3200-4 Pro	BLAUBOX MW 6500-4 Pro
G4 panel filter		FP 653x440x47 G4	FP 653x440x47 G4	-
G4 pocket filter		-	-	FPT 868x573x27 G4
Silencer		SD 60x30	SD 60x35	SD 80x50
Duct cooling unit		KFK 60x30-3	KFK 60x35-3	KFK 80x50-3
Duct cooling unit		KWK 60x30-3	KWK 60x35-3	KWK 80x50-3
Water mixing unit		WMG	WMG	WMG
Air flow dampers		SL 60x30	SL 60x35	SL 80x50
Flexible anti-vibration connector		EVA 60x30	EVA 60x35	EVA 80x50
Air damper electric actuator		LF230	LF230	LF230
Air damper electric actuator		TF230	TF230	TF230

BLAUBOX DE PRO

Supply suspended ventilation units

Features

- Ventilation units for efficient supply ventilation in various premises.
- Controllable air supply, heating and filtration.
- Compatible with 400x200, 500x300 and 600x350 mm rectangular air ducts.



Air flow:
up to 3350 m³/h
931 l/s



Design

- The casing is made of double-skinned aluzinc panels, internally filled with 50 mm mineral wool layer for heat and sound insulation.
- The casing has fixing brackets with vibration absorbing connectors for easy installation.
- The hinged casing panel ensures easy access to the internals for cleaning, filter replacement and other maintenance operations.

Fans

- Asynchronous external rotor motor and centrifugal high-pressure impeller with backward curved blades is used for air supply.
- Integrated motor overheating protection with automatic restart.
- Dynamically balanced impeller.
- Equipped with ball bearings for longer service life.
- Reliable and quiet operation.

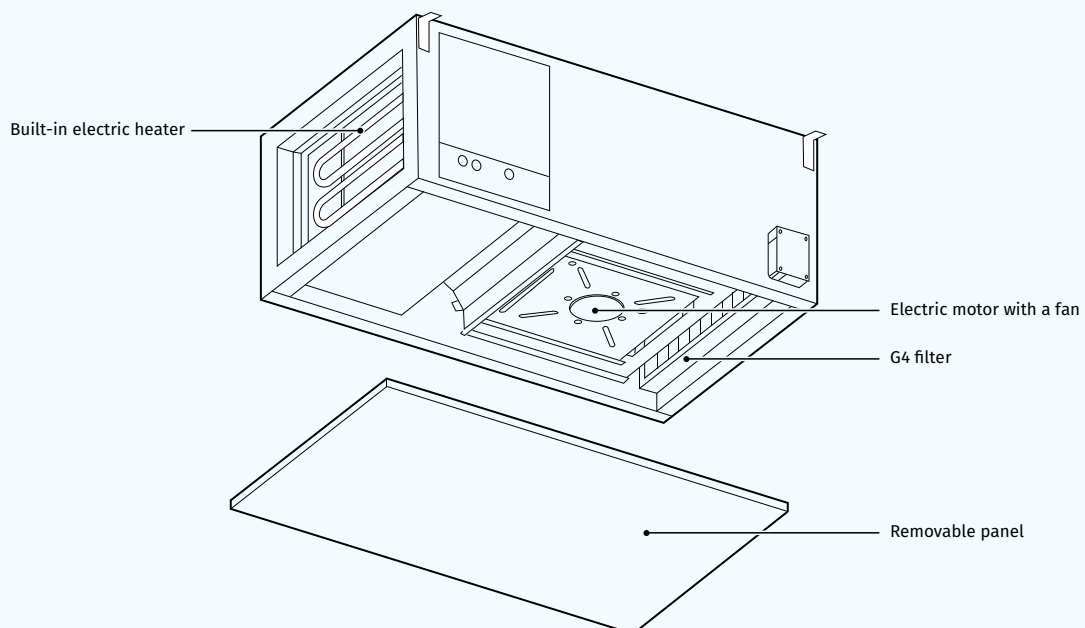

Air heater

- The units are equipped with an electric heater for operation during cold seasons at low outside temperature.
- Two integrated overheat protection thermostats, one actuated at +60 °C with automatic restart and the other one actuated at +90 °C with manual restart.

Air filtration

- The built-in G4 supply filter provides air filtration.

Control and automation

- The units incorporate an integrated control system with a wall-mounted control panel and LCD display.
- The standard delivery set includes a 10 m cable for connection of the unit and the control panel.
- **Control panel functions:**
 - Activating/deactivating the unit.
 - Setting low, medium and high speeds for the supply fan. Air flow control.
 - Supply air setting and maintaining.
 - Display of indoor air temperature.
 - Display of errors (alarms) and filter replacement indication.
 - Setting or week-scheduled operation of the unit.

Automation functions:

- Overheating protection of the electric heating elements.
- Disabling heater activation during the fan shutoff.
- Filter clogging control with a pressostat.
- All the operation parameters are individually adjustable.

Mounting

- The unit is suitable for mounting on the floor, ceiling mounting or wall mounting with fixing brackets in any mounting position except for the vertical one with air flow downwards.
- Wiring via the terminal block in the terminal box.
- The correct mounted unit must provide free access to the hinged panel for servicing and filter replacement.

Designation key

Series	Casing modification	Heater type	Rated air flow [m³/h]	Electric heater power [kW]	Control
BLAUBOX	D: Suspended mounting	E: electric heater	1300; 2500; 3300	– 12; 18; 21	Pro: with control panel

Overall dimensions [mm]

Model	B	B1	B2	B3	H	H1	H2	L	L1
BLAUBOX DE 1300-12 Pro	400	420	624	582	200	220	374	1145	1106
BLAUBOX DE 2500-18 Pro	500	520	689	646	300	320	447	1250	1212
BLAUBOX DE 3300-21 Pro	600	620	888	744	350	370	500	1252	1212

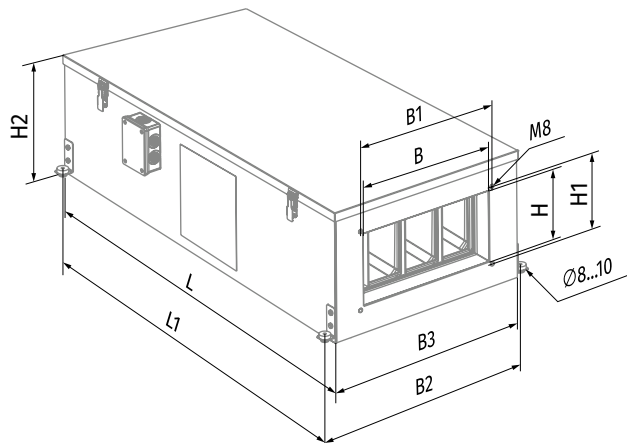

Technical data

Parameters	BLAUBOX DE 1300-12 Pro	BLAUBOX DE 2500-18 Pro	BLAUBOX DE 3300-21 Pro
Voltage [V / 50 Hz]	3 ~ 400	3 ~ 400	3 ~ 400
Power [kW]	0.32	0.62	1.33
Current [A]	0.55	1.05	2.4
Electric heater power [kW]	12.0	18.0	21.0
Electric heater current [A]	17.4	26.0	30.0
Unit power [kW]	12.32	18.62	22.33
Unit current [A]	17.95	27.05	32.4
Maximum air flow [m ³ /h (l/s)]	1275 (354)	2500 (695)	3350 (931)
RPM [min ⁻¹]	2700	2690	2730
Sound pressure level at 3 m [dBA]	51	54	57
Transported air temperature [°C]	-25...+40	-25...+40	-25...+40
Casing material	aluzinc	aluzinc	aluzinc
Insulation	50 mm mineral wool	50 mm mineral wool	50 mm mineral wool
Filter	G4	G4	G4
Connected air duct diameter [mm]	400x200	500x300	600x350
Weight [kg]	56	61	91
ErP	2016, 2018	2016, 2018	2016, 2018

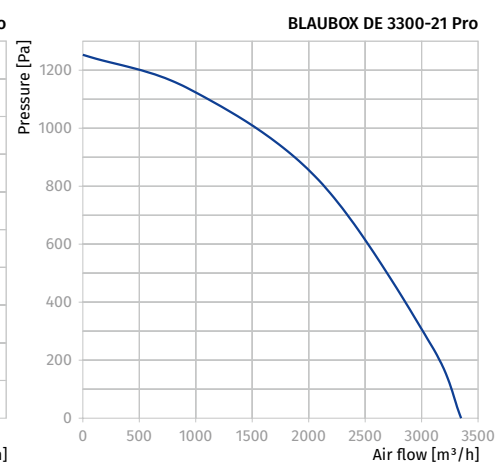
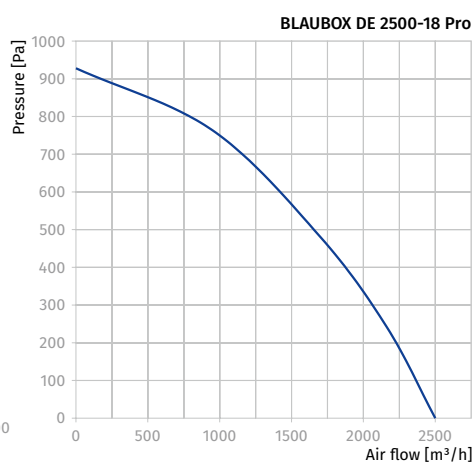
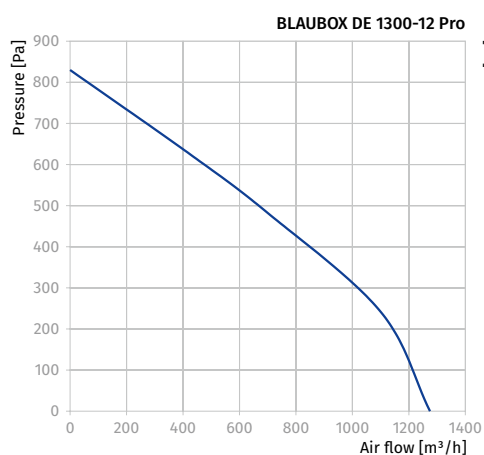

Accessories

		BLAUBOX DE 1300-12 Pro	BLAUBOX DE 2500-18 Pro	BLAUBOX DE 3300-21 Pro
G4 panel filter		FP 442x275x47 G4	FP 442x275x47 G4	FP 545x390x47 G4
Silencer		SD 40x20	SD 50x30	SD 60x35
Duct cooling unit		KFK 40x20-3	KFK 50x30-3	KFK 60x35-3
Duct cooling unit		KWK 40x20-3	KWK 50x30-3	KWK 60x35-3
Air flow dampers		SL 40x20	SL 50x30	SL 560x35
Flexible anti-vibration connector		EVA 40x20	EVA 50x30	EVA 60x35
Air damper electric actuator		LF230	LF230	LF230
Air damper electric actuator		TF230	TF230	TF230

BLAUBOX DW PRO

Supply suspended ventilation units

Features

- Ventilation units for efficient supply ventilation in various premises.
- Controllable air supply, heating and filtration.
- Compatible with 400x200 up to 700x400 mm rectangular air ducts.



Air flow:
up to 4100 m³/h
1139 l/s



Design

- The casing is made of double-skinned aluzinc panels, internally filled with 50 mm mineral wool layer for heat and sound insulation.
- The casing has fixing brackets with vibration absorbing connectors for easy installation.
- The hinged casing panel ensures easy access to the internals for cleaning, filter replacement and other maintenance operations.

Fans

- Asynchronous external rotor motor and centrifugal high-pressure impeller with backward curved blades is used for air supply.
- Integrated motor overheating protection with automatic restart.
- Dynamically balanced impeller.
- Equipped with ball bearings for longer service life.
- Reliable and quiet operation.

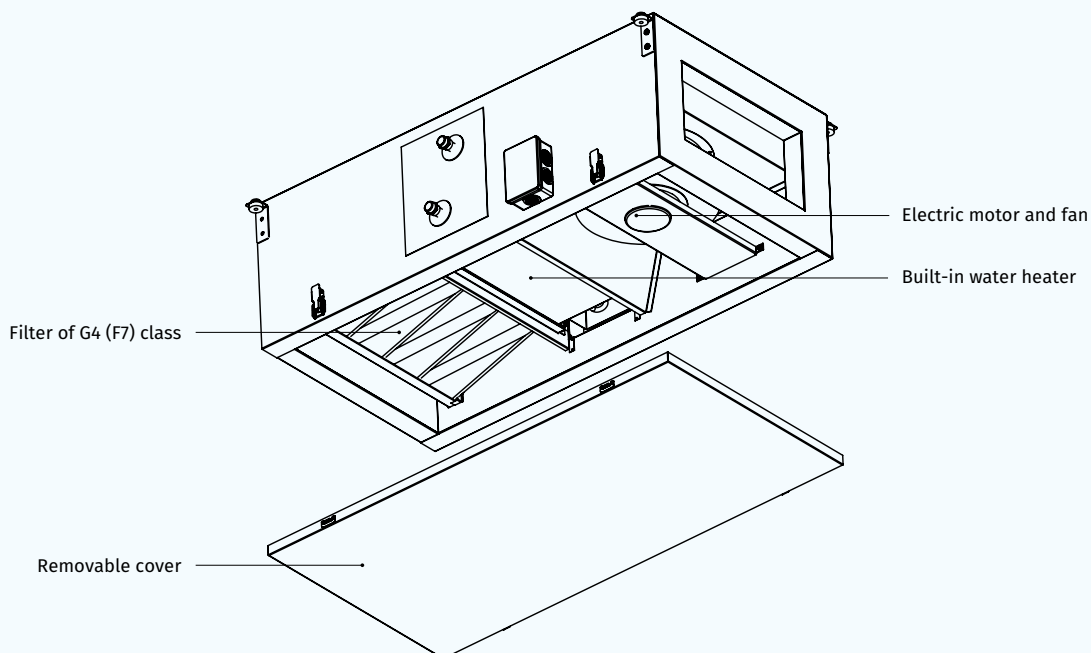

Air heater

- The units are equipped with a water (glycol) heater for operation during cold seasons at low outside temperature.
- The air temperature sensor downstream of the water heater and the return heat medium sensor ensure freezing protection of the water heater. If any of these sensors detects a temperature point below the set minimum value, the signal is sent automatically to the control unit to troubleshoot cooling.

Air filtration

- The built-in G4 supply filter provides air filtration.
- Optionally a F7 filter may be installed for efficient filtration.

Control and automation

- The units incorporate an integrated control system with a wall-mounted control panel and LCD display.
- The standard delivery set includes a 10 m cable for connection of the unit and the control panel.
- **Control panel functions:**
 - Activating/deactivating the unit.
 - Setting low, medium and high speeds for the supply fan. Air flow control.
 - Setting and maintaining of indoor air temperature.
 - Display of the indoor air temperature.
 - Supply filter clogging control according to the pressostat.
 - Alarm indication.

Automation functions:

- Control of the supply air damper actuator (separate order).
- Smooth rotation speed control of the fan (3 ~ 400 V, 50 Hz).
- Water heater control.
- Generation of the activation signal for the exhaust fan if available in the system.
- Shutdown of the unit on signal from the fire alarm panel.
- Control of the cooler with respect to the set indoor air temperature (separate order).
- All the operation parameters are individually adjustable.

Mounting

- The unit is suitable for mounting on the floor, ceiling mounting or wall mounting with fixing brackets in any mounting position except for the vertical one with air flow downwards.
- The correct mounted unit must provide free access to the hinged panel for servicing and filter replacement.

Designation key

Series	Casing modification	Heater type	Rated air flow [m³/h]	Number of water coil rows	Control
BLAUBOX	D: Suspended mounting	W: water heater	1200; 2300; 3200; 4100	– 3; 4	Pro: with control panel

Overall dimensions [mm]

Model	B	B1	B2	B3	H	H1	H2	L	L1
BLAUBOX DW 1200-4 Pro	400	420	624	582	200	220	374	1145	1106
BLAUBOX DW 2300-4 Pro	500	520	689	646	300	320	447	1250	1212
BLAUBOX DW 3200-4 Pro	600	620	787	744	350	370	500	1252	1212
BLAUBOX DW 4100-3 Pro	700	720	888	844	400	420	546	1302	1262

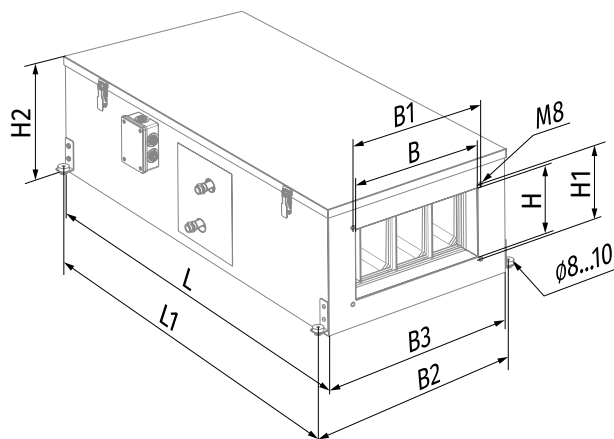

Technical data

Parameters	BLAUBOX DW 1200-4 Pro	BLAUBOX DW 2300-4 Pro	BLAUBOX DW 3200-4 Pro	BLAUBOX DW 4100-3 Pro
Voltage [V / 50 Hz]	3 ~ 400	3 ~ 400	3 ~ 400	3 ~ 400
Number of water (glycol) coil rows	4	4	4	3
Power [kW]	0.32	0.62	1.33	2.3
Current [A]	0.55	1.05	2.4	4.3
Maximum air flow [m ³ /h (l/s)]	1200 (333)	2350 (653)	3260 (906)	4100 (1139)
RPM [min ⁻¹]	2700	2690	2730	2840
Sound pressure level at 3 m [dBA]	51	54	57	75
Transported air temperature [°C]	-25...+40	-25...+40	-25...+40	-25...+70
Casing material	aluzinc	aluzinc	aluzinc	aluzinc
Insulation	50 mm mineral wool	50 mm mineral wool	50 mm mineral wool	50 mm mineral wool
Supply filter	G4 (option: F7)	G4 (option: F7)	G4 (option: F7)	G4 (option: F7)
Connected air duct diameter [mm]	400x200	500x300	600x350	700x400
Weight [kg]	57	63	94	110
ErP	2016, 2018	2016, 2018	2016, 2018	2016, 2018

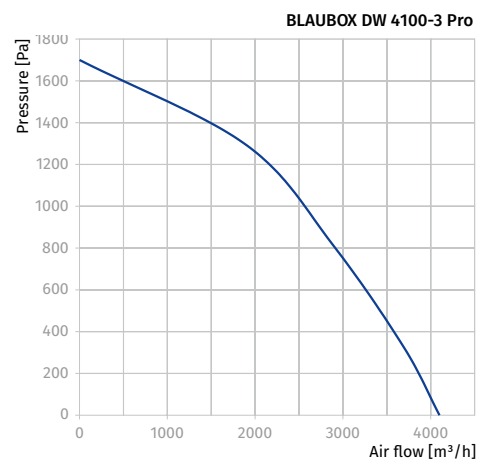
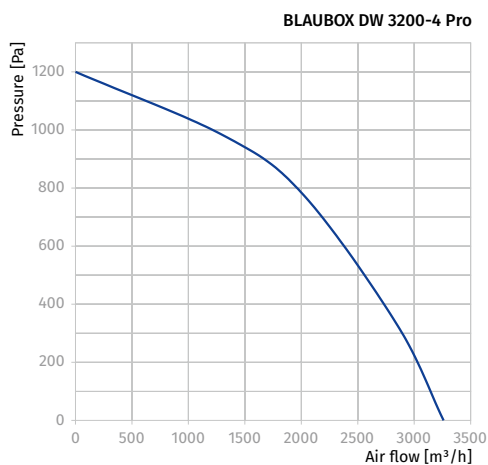
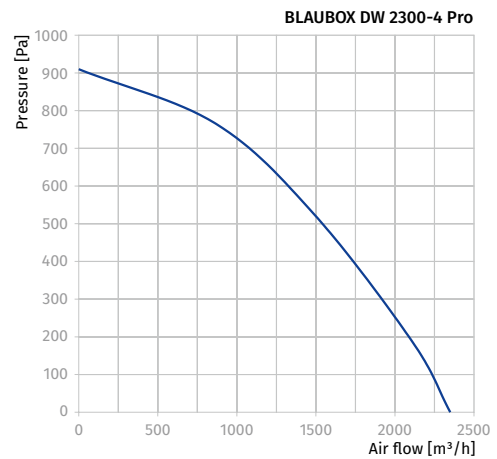
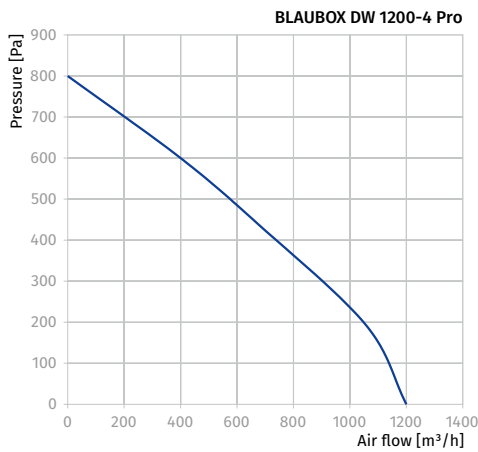

BLAUBOX DW 1200-4 PRO

Air temperature downstream of the water heating coils [°C]

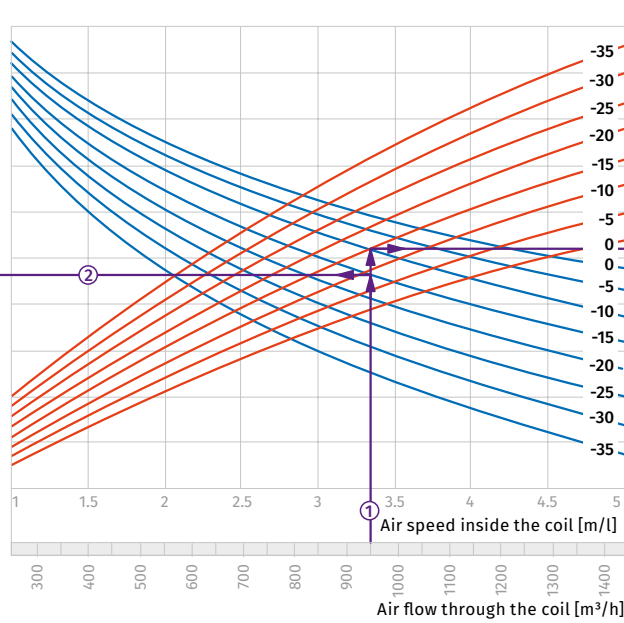
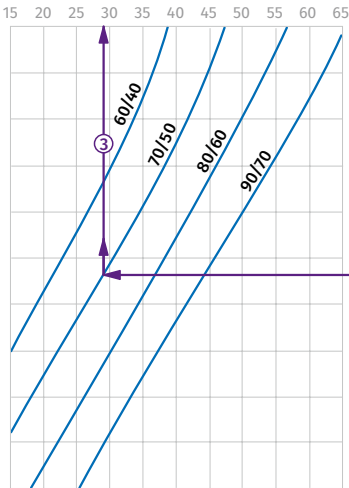

Coil heating capacity [kW]

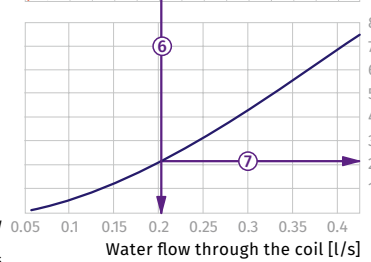
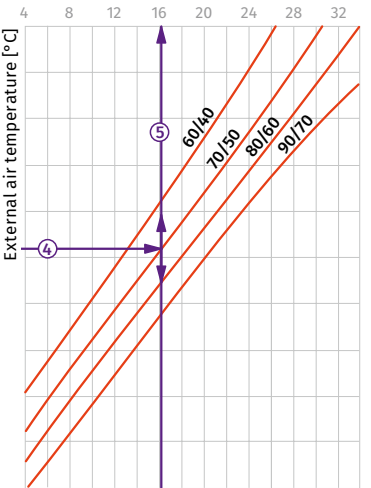

How to use water heater diagrams.

The air flow is 350 m³/h and the air speed in the cooling unit is 3.35 m/s ①.

- To calculate the maximum air temperature find the intersection point of the air flow line ① with the rated outer temperature shown in blue line (e.g., -15 °C) and draw the line ② to the left until it crosses the water in/out temperature curve (e.g. +70/+50). From this point draw a vertical line to the supply air temperature downstream of the heater (+29 °C) ③.
- To calculate the heater power find the intersection point of the air flow ① with the rated winter temperature shown in red line (e.g., -15 °C) and draw the line ④ to the right until it crosses the

- water in/out temperature curve (e.g. +70/+50). From this point draw a vertical line to the heater power axis (16.0 kW) ⑤.
- To calculate the required water flow in the heater prolong this line ⑥ downwards to the water flow axis (0.2 l/s).
- To calculate the water pressure drop in the heater find the intersection point of the line ⑥ with the pressure loss curve and prolong the line ⑦ to the right on the water pressure drop axis (2.1 kPa).

BLAUBOX DW 2300-4 PRO

Air temperature downstream of the water heating coils [°C]

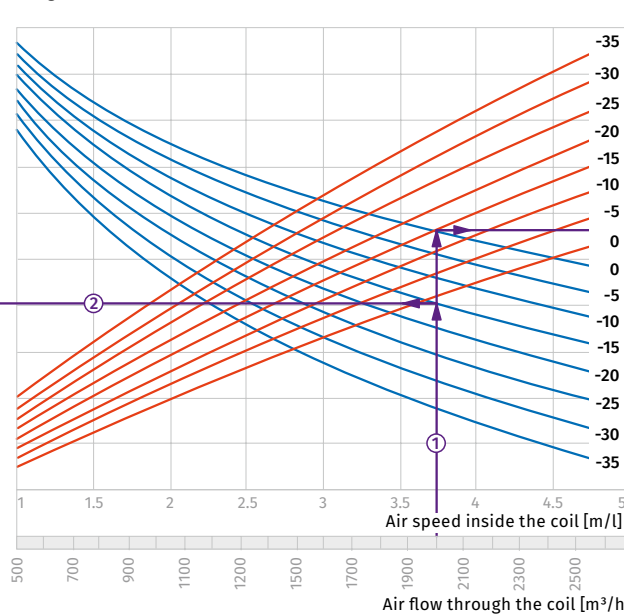
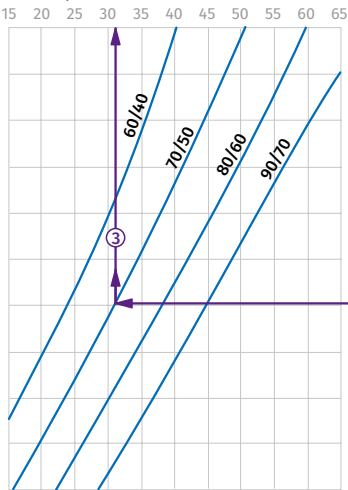

Coil heating capacity [kW]

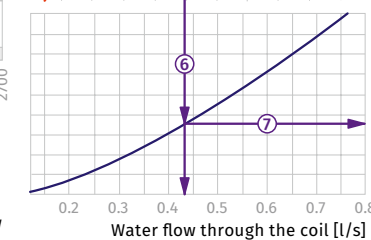
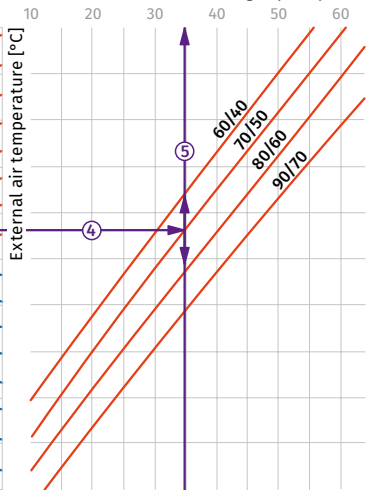

How to use water heater diagrams.

The air flow is 2000 m³/h and the air speed in the cooling unit is 3.75 m/s ①.

- To calculate the maximum air temperature find the intersection point of the air flow line ① with the rated outer temperature shown in blue line (e.g., -15 °C) and draw the line ② to the left until it crosses the water in/out temperature curve (e.g. +70/+50). From this point draw a vertical line to the supply air temperature downstream of the heater (+31 °C) ③.
- To calculate the heater power find the intersection point of the air flow ① with the rated winter temperature shown in red line (e.g., -15 °C) and draw the line ④ to the right until it crosses the

- water in/out temperature curve (e.g. +70/+50). From this point draw a vertical line to the heater power axis (35.0 kW) ⑤.
- To calculate the required water flow in the heater prolong this line ⑥ downwards to the water flow axis (0.43 l/s).
- To calculate the water pressure drop in the heater find the intersection point of the line ⑥ with the pressure loss curve and prolong the line ⑦ to the right on the water pressure drop axis (9.0 kPa).

BLAUBOX DW 3200-4 PRO

Air temperature downstream of the water heating coils [°C]

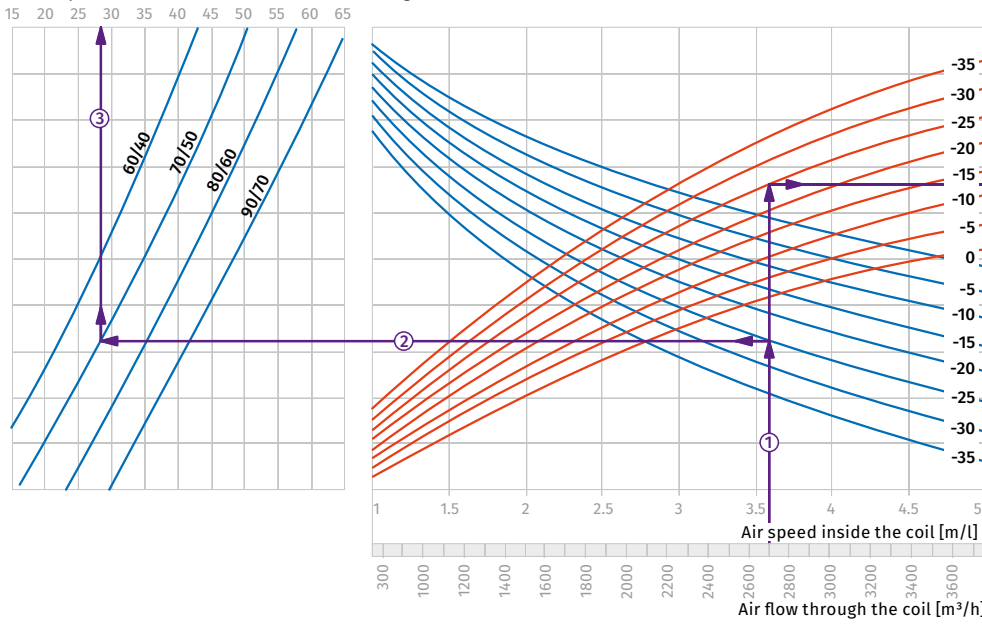

How to use water heater diagrams.

The air flow is 2700 m³/h and the air speed in the cooling unit is 3.59 m/s ①.

- To calculate the maximum air temperature find the intersection point of the air flow line ① with the rated outer temperature shown in blue line (e.g., -25 °C) and draw the line ② to the left until it crosses the water in/out temperature curve (e.g. +70/+50). From this point draw a vertical line to the supply air temperature downstream of the heater (+28 °C) ③.
- To calculate the heater power find the intersection point of the air flow ① with the rated winter temperature shown in red line (e.g., -25 °C) and draw the line ④ to the right until it crosses the

- water in/out temperature curve (e.g. +70/+50). From this point draw a vertical line to the heater power axis (58.0 kW) ⑤.
- To calculate the required water flow in the heater prolong this line ⑤ downwards to the water flow axis (0.73 l/s).
- To calculate the water pressure drop in the heater find the intersection point of the line ⑥ with the pressure loss curve and prolong the line ⑦ to the right on the water pressure drop axis (14.0 kPa).

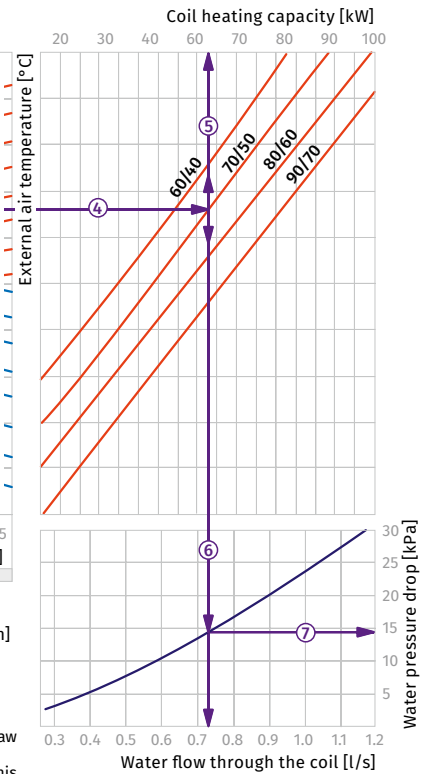

SUPPLY VENTILATION UNITS

BLAUBOX DW 4100-3 PRO

Air temperature downstream of the water heating coils [°C]

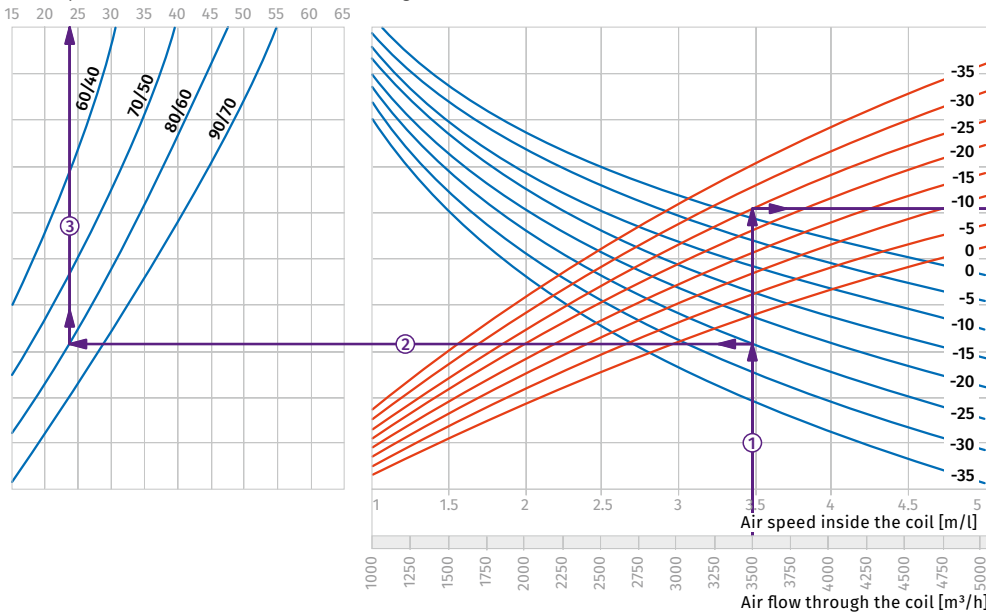

How to use water heater diagrams.







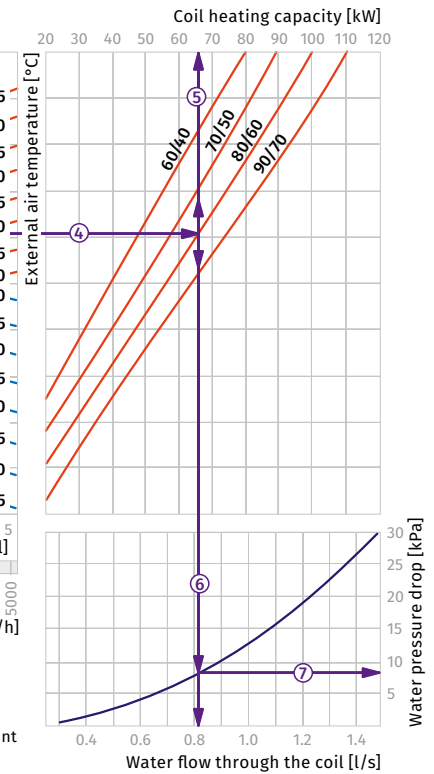

The air flow is 3500 m³/h and the air speed in the cooling unit is 3.48 m/s ①.

- To calculate the maximum air temperature find the intersection point of the air flow line ① with the rated outer temperature shown in blue line (e.g., -25 °C) and draw the line ② to the left until it crosses the water in/out temperature curve (e.g. +80/+60). From this point draw a vertical line to the supply air temperature downstream of the heater (+24 °C) ③.
- To calculate the heater power find the intersection point of the air flow ① with the rated winter temperature shown in red line (e.g., -25 °C) and draw the line ④ to the right until it crosses the

- water in/out temperature curve (e.g. +80/+60). From this point draw a vertical line to the heater power axis (65.0 kW) ⑤.
- To calculate the required water flow in the heater prolong this line ⑤ downwards to the water flow axis (0.81 l/s).
- To calculate the water pressure drop in the heater find the intersection point of the line ⑥ with the pressure loss curve and prolong the line ⑦ to the right on the water pressure drop axis (8.0 kPa).



Accessories

		BLAUBOX DW 1200-4 Pro	BLAUBOX DW 2300-4 Pro	BLAUBOX DW 3200-4 Pro	BLAUBOX DW 4100-3 Pro
G4 pocket filter		FPT 538x342x27 G4	FPT 538x342x27 G4	FPT 637x395x27 G4	FPT 737x441x27 G4
Silencer		SD 40x20	SD 50x30	SD 60x35	SD 80x50
Duct cooling unit		KFK 40x20-3	KFK 50x30-3	KFK 60x35-3	KFK 70x40-3
Duct cooling unit		KWK 40x20-3	KWK 50x30-3	KWK 60x35-3	KWK 70x40-3
Water mixing unit		WMG	WMG	WMG	WMG
Air flow dampers		SL 40x20	SL 50x30	SL 60x35	SL 70x40
Flexible anti-vibration connector		EVA 40x20	EVA 50x30	EVA 60x35	EVA 70x40
Air damper electric actuator		LF230	LF230	LF230	LF230
Air damper electric actuator		TF230	TF230	TF230	TF230

DAH 251-13

Kitchen exhaust hood

Features

- The kitchen exhaust hood is designed to clean air from combustion products, fumes, fumes and cooking smells.
- As the kitchen hood turns on, the air damper opens and the high speed activation signal is sent to the air handling unit.
- The kitchen exhaust hood is equipped with a light and a polyester filter.
- The kitchen exhaust hood is supplied with a cable and a mains plug.



Mounting

- The installation steps are described in the operation manual.
- The mounting accessories and screws are included with the unit.

Overall dimensions [mm]

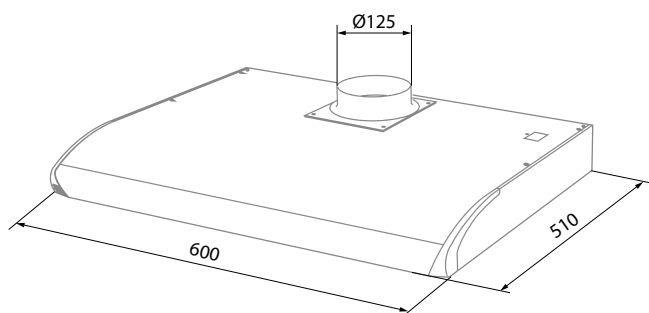

Technical data

Parameters	DAH 251-13
Voltage [V/50 (60) Hz]	230
Power consumption [W]	11

Mounting example

DAH 251-13 kitchen hood is suitable for direct connection to KOMFORT Roto E S(E) 200 S17/S18 unit.

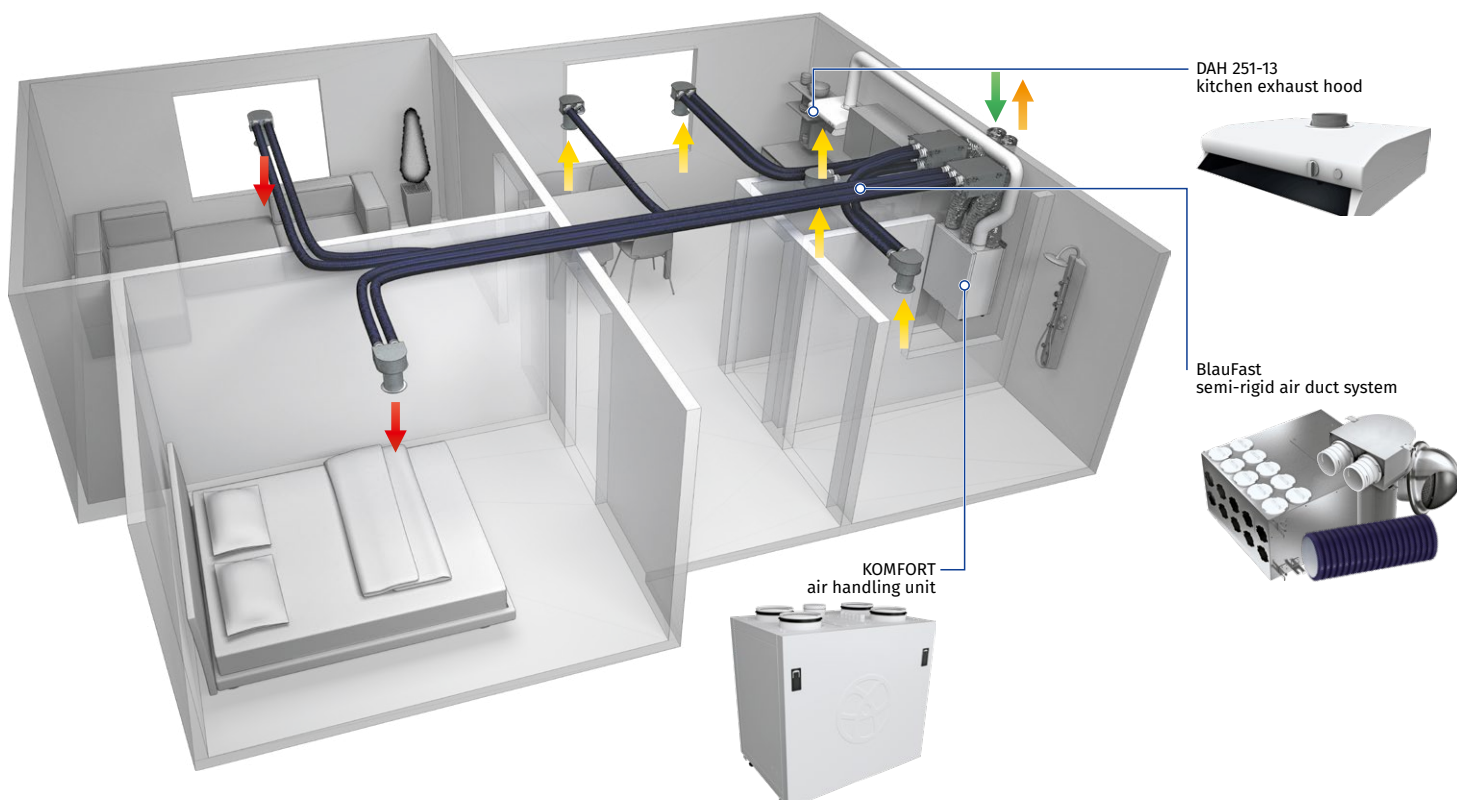

PCOS004850

Module for Modbus connection

Features

- The PSOS004850 control module is designed for connection of the pCO series controllers (except for pCOB) to ventilation control systems in compliance with Modbus - RS485 communication protocol.
- The PSOS004850 control module enables integration of the unit into a building management system.

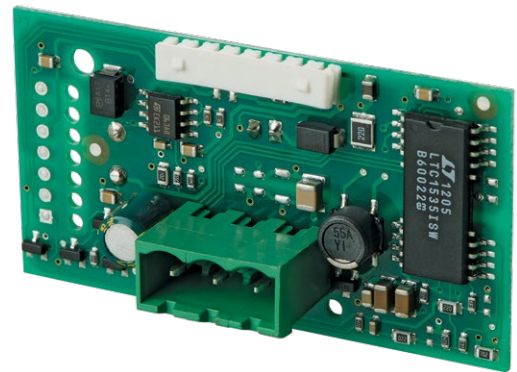

Compatibility

- The PSOS004850 control module is compatible with all the air handling units of KOMFORT Roto and CIVIC series with S17 and S18 controllers.

Technical data

Parameters	Values
Cable cross section, mm ²	0.2 – 2.5. Two-wire shielded twisted pair cable AWG20/22
Operating conditions	from -10 up to + 60 °C, relative humidity 90 %
Storage conditions	from -10 up to + 70 °C, relative humidity 90 %
Dimensions [mm]	60x29x20

EVH

Electric duct preheater for heat exchanger freeze protection

Features

- Heat exchanger freeze protection by means of preheating of the intake air.
- Maintains the duct air temperature at a point that prevents the heat exchanger freezing.
- Compatible with Ø 125 up to 250 mm air ducts.



Design

- The casing is internally filled with 20 mm layer of non-flammable mineral wool.
- The casing and the junction box are made of galvanized steel.
- Heating elements are made of stainless steel.
- Airtight connection to air ducts due to rubber seals.

Control

- Equipped with a power cable.
- The signal cable for connection to the controller of the air handling unit.
- Equipped with a triac power regulator. Regulation is carried out via switching-on and switching-off the full load. Load commutation is carried out by the semiconductor device (triac). The switching unit has no wearing mechanical elements.
- Equipped with overheat thermostats:**
 - main protection with automatic restart at +50 °C;
 - emergency protection with manual restart at +90 °C.

Mounting

- Fixation to round air ducts by means of clamp (included in the delivery).
- In case of horizontal mounting position the control box cover must be directed upwards only. Permitted deviation up to 90°. The control box cover may not be positioned downwards!

Compatibility chart

Heater model	Unit model
EVH 125	KOMFORT with spigot Ø 125 mm and S21 control panel
EVH 150	KOMFORT with spigot Ø 150 mm and S21 control panel
EVH 160	KOMFORT with spigot Ø 160 mm and S21 control panel
EVH 200	KOMFORT with spigot Ø 200 mm and S21 control panel
EVH 250	KOMFORT with spigot Ø 250 mm and S21 control panel

Overall dimensions [mm]

Model	Ø D	B	H	L	L1
EVH 125-0.6-1	124	155	251	306	190
EVH 125-0.8-1	124	155	251	306	190
EVH 125-1.2-1	124	155	251	306	190
EVH 150-0.8-1	149	170	282	306	190
EVH 150-1.2-1	149	170	282	306	190
EVH 150-1.7-1	149	170	282	306	190
EVH 150-2.0-1	149	170	282	306	190
EVH 160-0.8-1	159	175	293	306	190
EVH 160-1.2-1	159	175	293	306	190
EVH 160-1.7-1	159	175	293	306	190
EVH 160-2.0-1	159	175	293	306	190
EVH 200-1.2-1	199	195	337	306	190
EVH 200-1.7-1	199	195	337	306	190
EVH 200-2.0-1	199	195	337	306	190
EVH 250-1.2-1	247	287	388	307	190
EVH 250-2.0-1	247	287	388	307	190
EVH 250-3.0-1	247	287	388	307	190

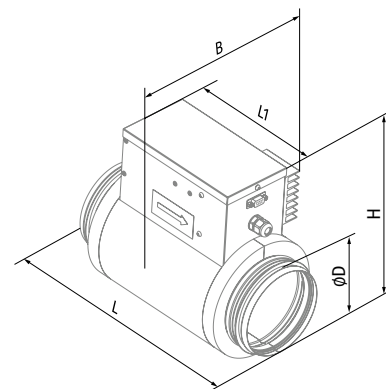

Designation key

Series	Connected air duct diameter [mm]	Heater power [kW]	Number of phases
EVH	125; 150; 160; 200; 250	- 0.6; 0.8; 1.2; 1.7; 2.0; 3.0	- 1: single-phase

Technical data

Parameters	Min. air flow [m³/h (l/s)]	Power [kW]	Current [A]
EVH 125-0.6-1	60 (17)	0.6	2.6
EVH 125-0.8-1	80 (22)	0.8	3.5
EVH 125-1.2-1	90 (25)	1.2	5.2
EVH 150-0.8-1	80 (22)	0.8	3.5
EVH 150-1.2-1	90 (25)	1.2	5.2
EVH 150-1.7-1	160 (44)	1.7	7.4
EVH 150-2.0-1	170 (47)	2.0	8.7
EVH 160-0.8-1	80 (22)	0.8	3.5
EVH 160-1.2-1	150 (42)	1.2	5.2
EVH 160-1.7-1	160 (44)	1.7	7.4
EVH 160-2.0-1	170 (47)	2.0	8.7
EVH 200-1.2-1	150 (42)	1.2	5.2
EVH 200-1.7-1	160 (44)	1.7	7.4
EVH 200-2.0-1	170 (47)	2.0	8.7
EVH 250-1.2-1	180 (50)	1.2	5.2
EVH 250-2.0-1	200 (56)	2.0	8.7
EVH 250-3.0-1	375 (104)	3.0	13.0

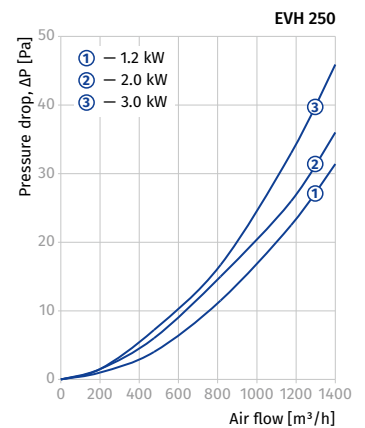
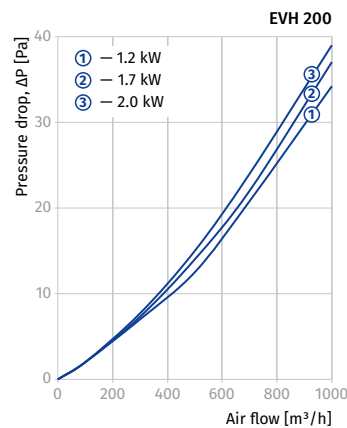
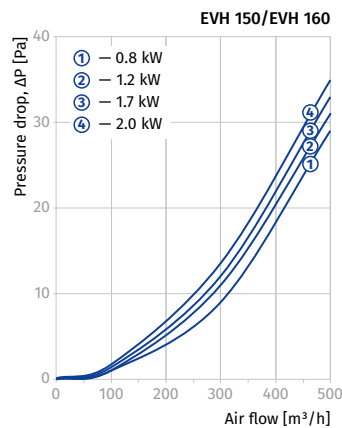
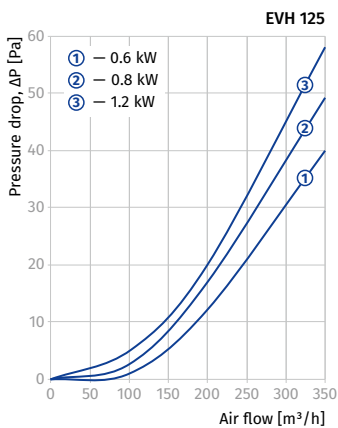

Heater capacity selection diagram

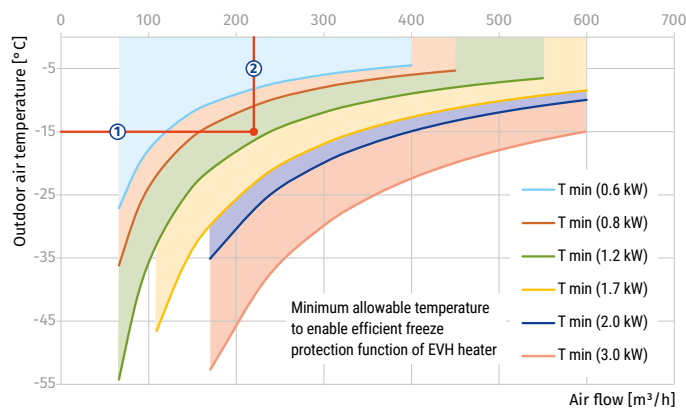

EVH heater parameters calculation example:

- It is necessary to select EVH freeze protection heater for the KOMFORT EC SB 350 S21 unit. Design outdoor air temperature in cold season is -15 °C. Design capacity is 220 m³/h.
- Identify the interception point of the air flow line (1) with the outdoor temperature line (2). In this case the heater with the capacity of 1200 W will assure efficient freeze protection of the heat exchanger. Select the **EVH 160-1.2-1** heater with the diameter corresponding to the diameter of the spigot of the KOMFORT EC SB 350 S21 unit.

ENH

Duct heater for supply air reheating

Features

- The heater is designed for integration into a ventilation system and joint operation with an air handling unit equipped with a control system used to switch on the heater and control its operation.
- The heater maintains the supply duct air temperature at a point set by the unit controller.
- Compatible with Ø 125 up to 250 mm air ducts.



Design

- The casing, the junction box and the heater cover are made of galvanized steel with the heating elements in stainless steel. The heater casing is additionally heat-insulated with 20 mm non-flammable mineral wool layer. The heaters are equipped with rubber seals for airtight connection to the air ducts.
- The ENH duct heaters are equipped with a power and a signal cable for connection of the heater to the air handling unit controller.
- The temperature is controlled by a triac power controller by means of switching the full load on and off. Load commutation is carried out by the semiconductor device (triac). The heaters are equipped with overheat thermostats:
 - main overheat protection with automatic reset at +50 °C
 - emergency overheat protection with manual reset at +90 °C.

Mounting

- The heater design ensures its mounting on the round ducts in any position by means of clamps (included in delivery). The air flow direction shall match the direction of the arrow on the heater casing.
- In case of horizontal mounting the control box must be installed with the cover upwards. Swivel range from the normal position up to max. 90°. Do not install the control box with the cover downwards.

Compatibility chart

Heater model	Unit model
ENH 125 ... S21	KOMFORT with spigot Ø 125 mm and S21 control panel
ENH 150 ... S21	KOMFORT with spigot Ø 150 mm and S21 control panel
ENH 160 ... S21	KOMFORT with spigot Ø 160 mm and S21 control panel
ENH 200 ... S21	KOMFORT with spigot Ø 200 mm and S21 control panel
ENH 250 ... S21	KOMFORT with spigot Ø 250 mm and S21 control panel

Overall dimensions [mm]

Model	Ø D	B	H	L	L1
ENH 125-0.6-1 S21	124	155	251	306	190
ENH 125-0.8-1 S21	124	155	251	306	190
ENH 125-1.2-1 S21	124	155	251	306	190
ENH 150-0.8-1 S21	149	170	282	306	190
ENH 150-1.2-1 S21	149	170	282	306	190
ENH 150-1.7-1 S21	149	170	282	306	190
ENH 150-2.0-1 S21	149	170	282	306	190
ENH 160-0.8-1 S21	159	175	293	306	190
ENH 160-1.2-1 S21	159	175	293	306	190
ENH 160-1.7-1 S21	159	175	293	306	190
ENH 160-2.0-1 S21	159	175	293	306	190
ENH 200-1.2-1 S21	199	195	337	306	190
ENH 200-1.7-1 S21	199	195	337	306	190
ENH 200-2.0-1 S21	199	195	337	306	190
ENH 250-1.2-1 S21	247	287	388	307	190
ENH 250-2.0-1 S21	247	287	388	307	190
ENH 250-3.0-1 S21	247	287	388	307	190

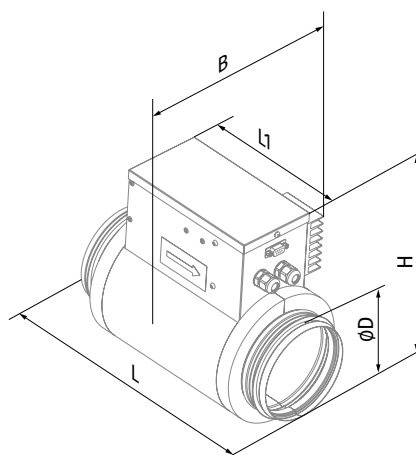

Designation key

Series	Connected air duct diameter [mm]	Heater power [kW]	Number of phases	Compatibility with automation
ENH	125; 160; 150; 200; 250	- 0.6; 0.8; 1.2; 1.7; 2.0; 3.0	- 1: single-phase	S21: compatible with S21 automation

Technical data

Parameters	Min. air flow [m³/h (l/s)]	Power [kW]	Current [A]
ENH 125-0.6-1 S21	60 (17)	0.6	2.6
ENH 125-0.8-1 S21	80 (22)	0.8	3.5
ENH 125-1.2-1 S21	90 (25)	1.2	5.2
ENH 150-0.8-1 S21	80 (22)	0.8	3.5
ENH 150-1.2-1 S21	90 (25)	1.2	5.2
ENH 150-1.7-1 S21	160 (44)	1.7	7.4
ENH 150-2.0-1 S21	170 (47)	2.0	8.7
ENH 160-0.8-1 S21	80 (22)	0.8	3.5
ENH 160-1.2-1 S21	150 (42)	1.2	5.2
ENH 160-1.7-1 S21	160 (44)	1.7	7.4
ENH 160-2.0-1 S21	170 (47)	2.0	8.7
ENH 200-1.2-1 S21	150 (42)	1.2	5.2
ENH 200-1.7-1 S21	160 (44)	1.7	7.4
ENH 200-2.0-1 S21	170 (47)	2.0	8.7
ENH 250-1.2-1 S21	180 (50)	1.2	5.2
ENH 250-2.0-1 S21	200 (56)	2.0	8.7
ENH 250-3.0-1 S21	375 (104)	3.0	13.0

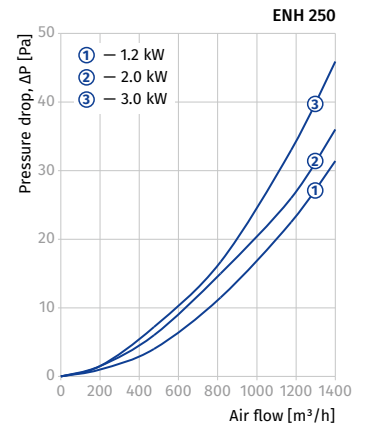
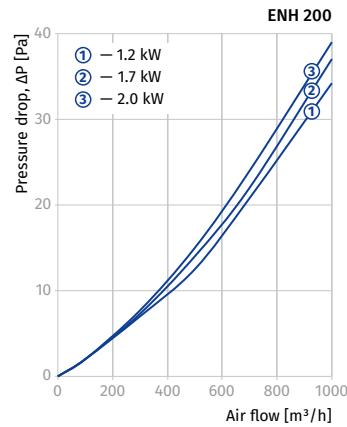
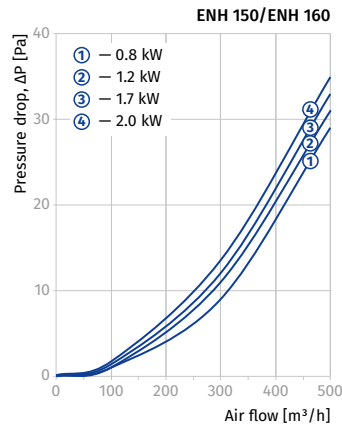
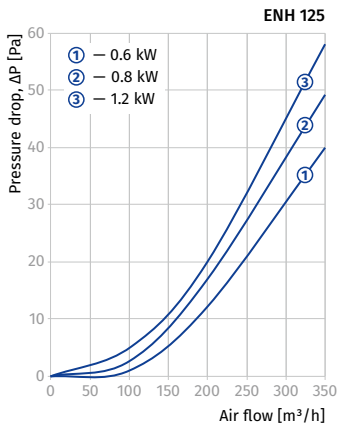

HEATERS

Heater capacity selection diagram

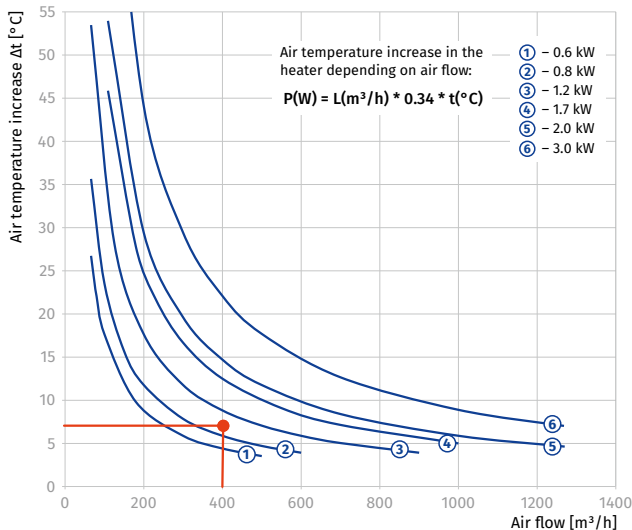

• The ENH heater parameters calculation example:

- It is necessary to select a heater for supply air post-heating to a temperature of +24 °C, provided the temperature downstream of the heat exchanger is +17 °C. Therefore it is essential to increase temperature by +7 °C. The ventilation system incorporates the KOMFORT EC SB 350 S21. Rated air capacity 400 m³/h.
- Determine the intersection of the post-heating temperature line (+7 °C) and the rated air capacity line (400 m³/h). In this case the 1200 W heater capacity provides necessary post-heating (+7 °C). The **ENH 160-1.2-1** with the diameter matching the spigot diameter of the air handling unit KOMFORT EC SB 350 S21 is a suitable model.

WKH

Duct water heaters for round ducts

Features

- For warming up of supply air in ventilation systems installed in various premises.
- Suitable for installation in supply or air handling units to warm up the supply air flow.
- For indoor use only if water serves as a heat carrier. For outdoor features use antifreezing mixture (ethylene glycol solution).
- Compatible with Ø 100 to 315 mm round air ducts.



Design

- Galvanized steel casing.
- Copper pipe manifold.
- Heat exchange surface made of aluminium plates.
- Airtight connection with air ducts due to rubber seals.
- Equipped with a nipple for the system deaeration.
- Outlet header is equipped with a spigot for installation of an immersion temperature sensor or freezing protection mechanism.
- Available in two- or four-row coil modifications.
- Suitable for operation at maximum operating pressure 1.6 MPa (16 bar) and maximum operating temperature +100 °C.

Mounting

- Fixing to round ducts with clamps.
- Any mounting position that ensures the heater deaeration.
- Install a filter upstream to the heater to protect heating elements against dirt ingress.

- Install the heater in front or behind the fan. In case of mounting behind the fan ensure a distance of not less than two connecting diameters for air flow stabilization and keep the maximum permissible air temperature inside the fan.
- Connect the heater on counter-flow basis, otherwise its capacity drops by 5–15 %. All the nomographic charts are rated for counter-flow connection.
- For correct and safe heater operation an automatic control and protection system is recommended, including the following functions:
 - regulation of the heating capacity and temperature of the air heated up;
 - filter clogging control by a differential air pressure sensor;
 - ventilation system start-up with pre-heated heater;
 - use of air dampers fitted with a spring return actuator;
 - fan turns off in case of freezing danger for the heater.

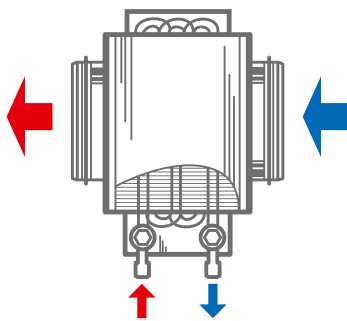

Connection against air flow

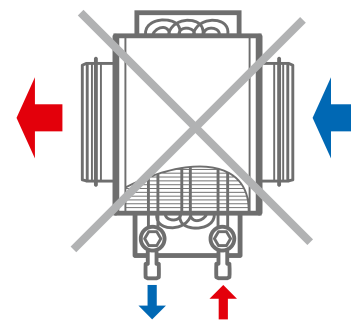

Connection along air flow

Designation key

Series	Connected air duct diameter [mm]	Number of water (glycol) coil rows
WKH	100; 125; 150; 160; 200; 250; 315	- 2; 4

Overall dimensions [mm]

Model	D	B	H	H2	L	L1	L2	L3	K	Number of water coil rows	Weight [kg]
WKH 100-2	100	350	240	150	300	82	43	220	G 3/4"	2	4.5
WKH 100-4	100	350	240	150	300	78	65	220	G 3/4"	4	5.2
WKH 125-2	125	350	240	150	300	82	43	220	G 3/4"	2	4.5
WKH 125-4	125	350	240	150	300	78	65	220	G 3/4"	4	5.2
WKH 150-2	150	400	290	200	300	82	43	220	G 3/4"	2	7.5
WKH 150-4	150	400	290	200	300	78	65	220	G 3/4"	4	8.2
WKH 160-2	160	400	290	200	300	82	43	220	G 3/4"	2	7.5
WKH 160-4	160	400	290	200	300	78	65	220	G 3/4"	4	8.2
WKH 200-2	200	400	290	200	300	82	43	220	G 3/4"	2	7.5
WKH 200-4	200	400	290	200	300	78	65	220	G 3/4"	4	8.2
WKH 250-2	250	470	360	270	350	107	43	270	G 1"	2	10.3
WKH 250-4	250	470	360	270	350	103	65	270	G 1"	4	10.8
WKH 315-2	315	550	440	350	450	157	43	370	G 1"	2	11.5
WKH 315-4	315	550	440	350	450	153	65	370	G 1"	4	12.2

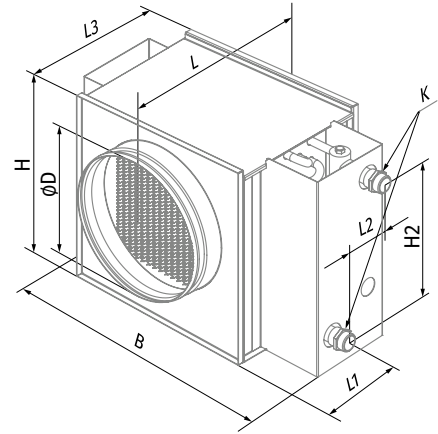

WKH ROUND HEATERS

Air pressure loss for water heaters WKH

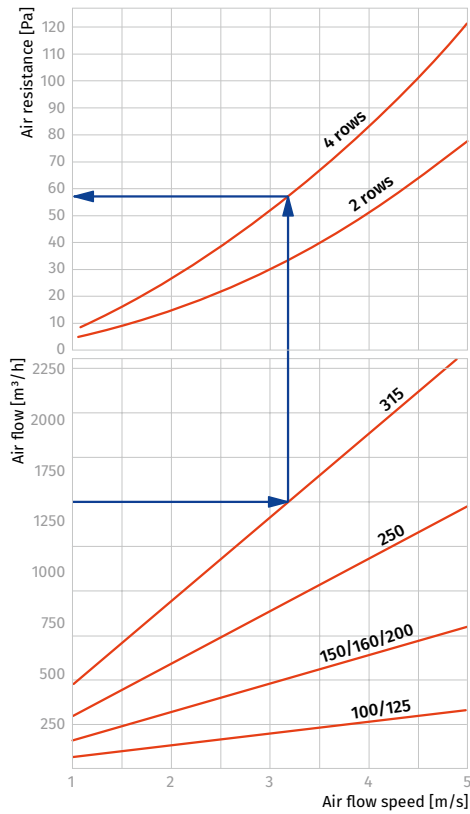

Water heaters calculation diagram

WKH 100-2 / WKH 125-2

Air temperature downstream of the water heating coils [°C]

5 10 15 20 25 30 35 40 45 50 55

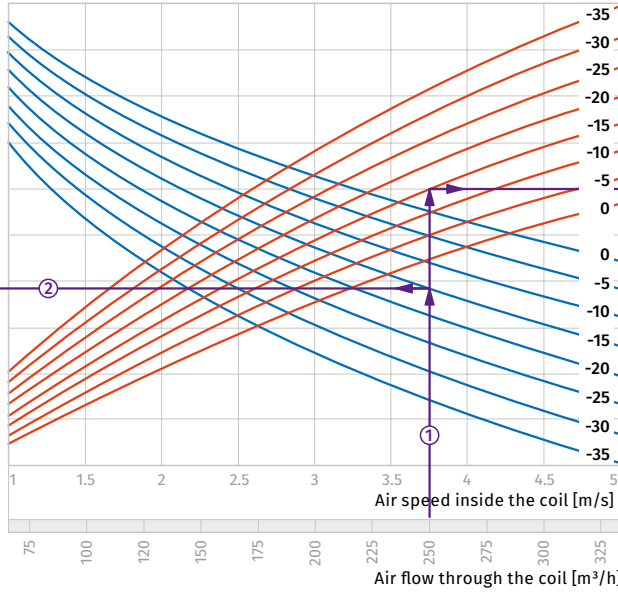
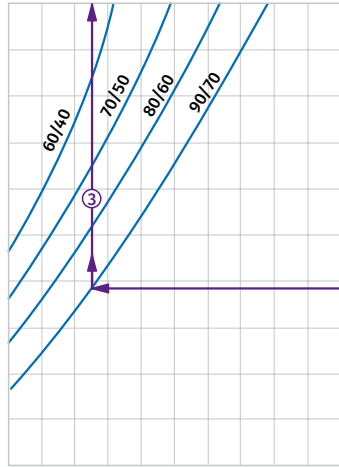

Coil heating capacity [kW]

0.5 1 1.5 2 2.5 3 3.5 4 4.5 5

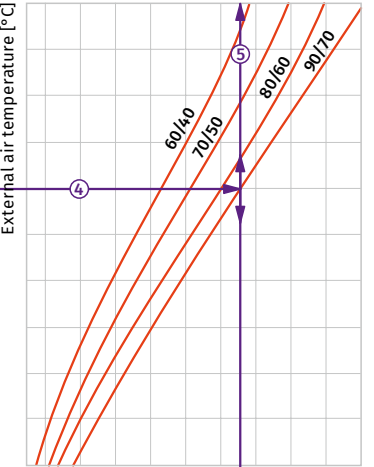

External air temperature [°C]

-35 -30 -25 -20 -15 -10 -5 0 5 10 15 20 25 30 35

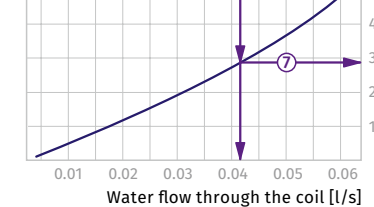

Water flow through the coil [l/s]

0.01 0.02 0.03 0.04 0.05 0.06

Water pressure drop [kPa]

5 4 3 2 1

How to use water heater diagrams.

System Parameters: Air flow = 250 m³/h.
Outside air temperature = -15 °C.
Water temperature (in/out) = +90/+70 °C.
The air flow is 250 m³/h and the air speed in the heater is 3.75 m/s ①.

- To calculate the maximum air temperature find the intersection point of the air flow line ① with the rated outer temperature shown in blue line (e.g., -15 °C) and draw the line ② to the left until it crosses the water in/out temperature curve (e.g., +90/+70). From this point draw a vertical line to the supply air temperature downstream of the heater (+17.5 °C) ③.

- To calculate the heater power find the intersection point of the air flow ① with the rated winter temperature shown in red line (e.g., -15 °C) and draw the line ④ to the right until it crosses the water in/out temperature curve (e.g., +90/+70). From this point draw a vertical line to the heater power axis (3.25 kW) ⑤.

- To calculate the required water flow in the heater prolong this line ⑥ downwards to the water flow axis (0.04 l/s).
- To calculate the water pressure drop in the heater find the intersection point of the line ⑥ with the pressure loss curve and prolong the line ⑦ to the right on the water pressure drop axis (2.9 kPa).

WKH 100-4 / WKH 125-4

Air temperature downstream of the water heating coils [°C]

15 20 25 30 35 40 45 50 55 60 65

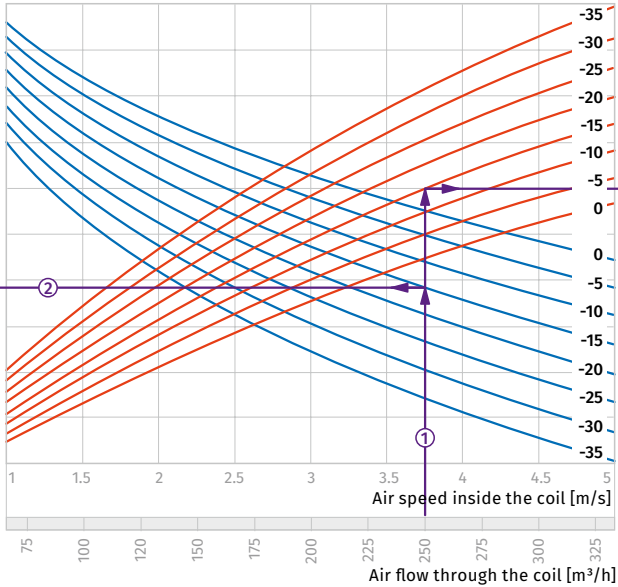
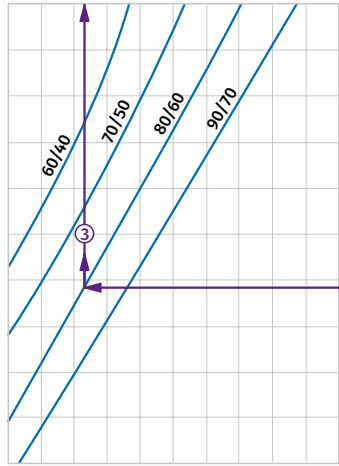

Coil heating capacity [kW]

1 2 3 4 5 6 7 8 9 10

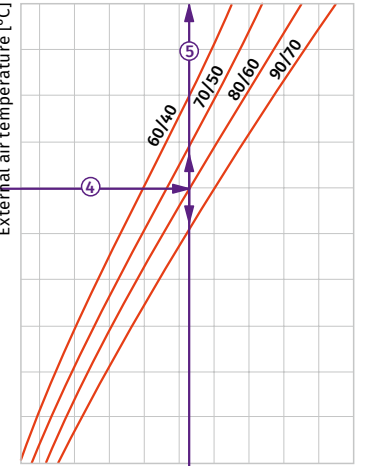

External air temperature [°C]

-35 -30 -25 -20 -15 -10 -5 0 5 10 15 20 25 30 35

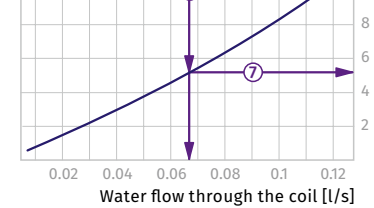

Water flow through the coil [l/s]

0.02 0.04 0.06 0.08 0.1 0.12

Water pressure drop [kPa]

10 8 6 4 2

How to use water heater diagrams.

System Parameters: Air flow = 250 m³/h.
Outside air temperature = -15 °C.
Water temperature (in/out) = +80/+60 °C.
The air flow is 250 m³/h and the air speed in the heater is 3.75 m/s ①.

- To calculate the maximum air temperature find the intersection point of the air flow line ① with the rated outer temperature shown in blue line (e.g., -15 °C) and draw the line ② to the left until it crosses the water in/out temperature curve (e.g., +80/+60). From this point draw a vertical line to the supply air temperature downstream of the heater (+27 °C) ③.

- To calculate the heater power find the intersection point of the air flow ① with the rated winter temperature shown in red line (e.g., -15 °C) and draw the line ④ to the right until it crosses the water in/out temperature curve (e.g., +80/+60). From this point draw a vertical line to the heater power axis (5.2 kW) ⑤.

- To calculate the required water flow in the heater prolong this line ⑥ downwards to the water flow axis (0.067 l/s).
- To calculate the water pressure drop in the heater find the intersection point of the line ⑥ with the pressure loss curve and prolong the line ⑦ to the right on the water pressure drop axis (5.2 kPa).

WKH 150-2 / WKH 160-2 / WKH 200-2

Air temperature downstream of the water heating coils [°C]

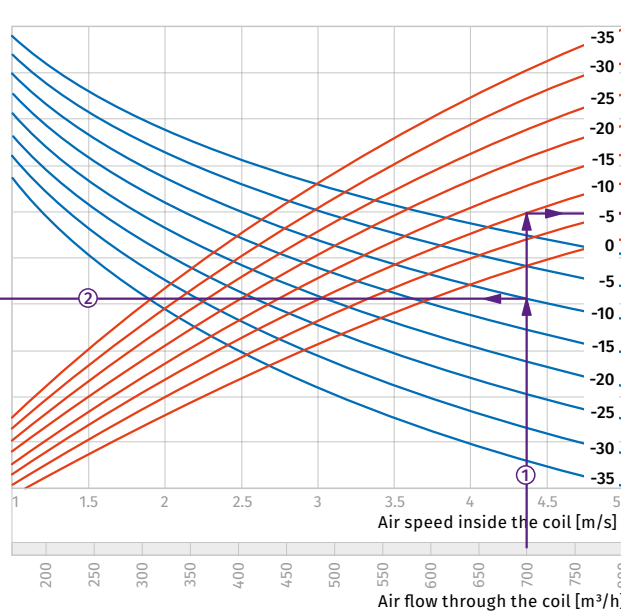
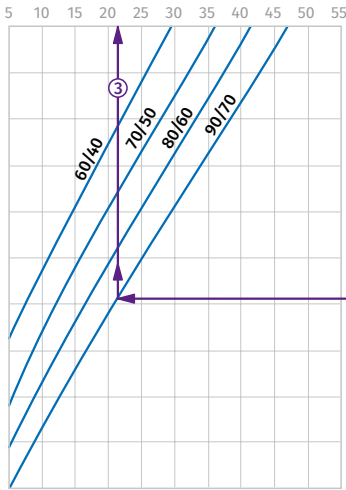

Coil heating capacity [kW]

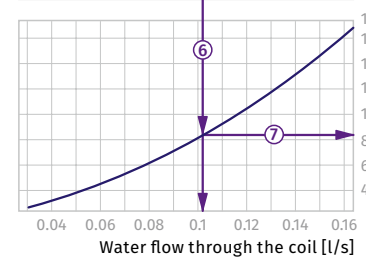
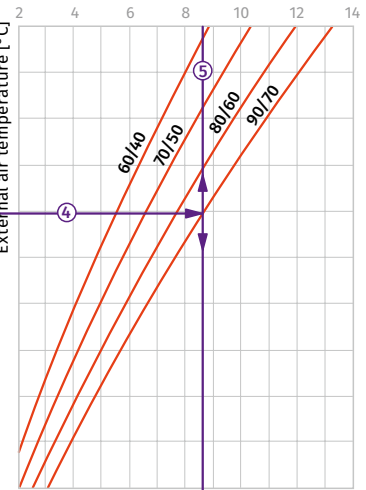

How to use water heater diagrams.

System Parameters: Air flow = 700 m³/h.
 Outside air temperature = -10 °C.
 Water temperature (in/out) = +90/+70 °C.
 The air flow is 700 m³/h and the air speed in the heater is 4.4 m/s ①.

- To calculate the maximum air temperature find the intersection point of the air flow line ① with the rated outer temperature shown in blue line (e.g., -10 °C) and draw the line ② to the left until it crosses the water in/out temperature curve (e.g., +90/+70). From this point draw a vertical line to the supply air temperature downstream of the heater (+21 °C) ③.

- To calculate the heater power find the intersection point of the air flow ① with the rated winter temperature shown in red line (e.g., -10 °C) and draw the line ④ to the right until it crosses the water in/out temperature curve (e.g., +90/+70). From this point draw a vertical line to the heater power axis (8.6 kW) ⑤.

- To calculate the required water flow in the heater prolong this line ⑥ downwards to the water flow axis (0.11 l/s).
- To calculate the water pressure drop in the heater find the intersection point of the line ⑥ with the pressure loss curve and prolong the line ⑦ to the right on the water pressure drop axis (8.2 kPa).

WKH 150-4 / WKH 160-4 / WKH 200-4

Air temperature downstream of the water heating coils [°C]

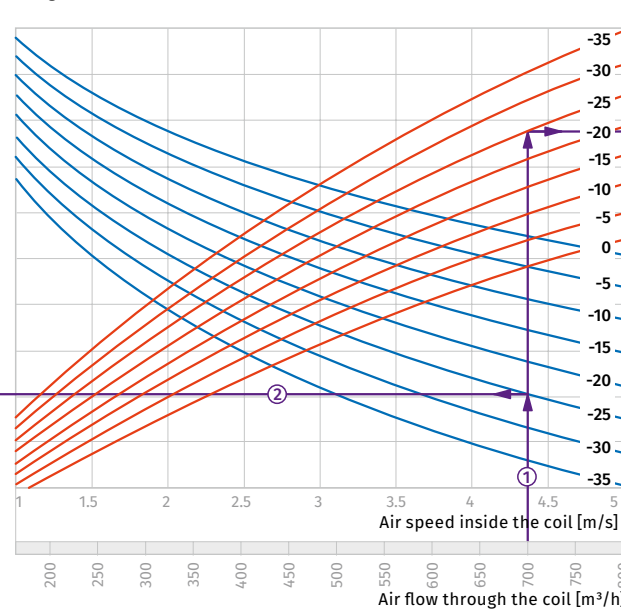
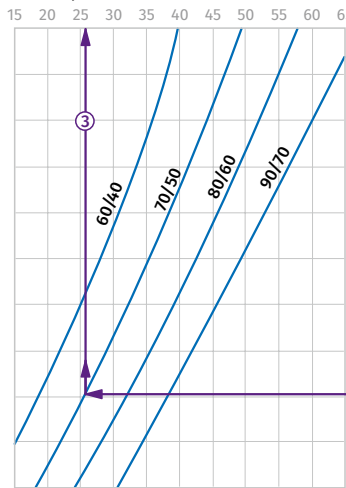

Coil heating capacity [kW]

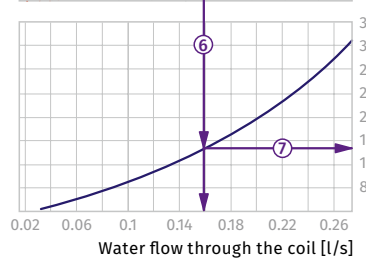
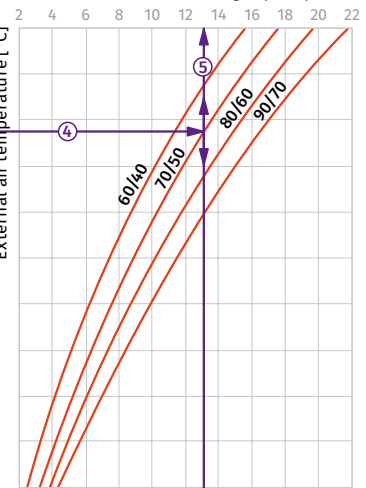

How to use water heater diagrams.

System Parameters: Air flow = 700 m³/h.
 Outside air temperature = -25 °C.
 Water temperature (in/out) = +70/+50 °C.
 The air flow is 700 m³/h and the air speed in the heater is 4.4 m/s ①.

- To calculate the maximum air temperature find the intersection point of the air flow line ① with the rated outer temperature shown in blue line (e.g., -25 °C) and draw the line ② to the left until it crosses the water in/out temperature curve (e.g., +70/+50). From this point draw a vertical line to the supply air temperature downstream of the heater (+26 °C) ③.

- To calculate the heater power find the intersection point of the air flow ① with the rated winter temperature shown in red line (e.g., -25 °C) and draw the line ④ to the right until it crosses the water in/out temperature curve (e.g., +70/+50). From this point draw a vertical line to the heater power axis (13.0 kW) ⑤.

- To calculate the required water flow in the heater prolong this line ⑥ downwards to the water flow axis (0.16 l/s).
- To calculate the water pressure drop in the heater find the intersection point of the line ⑥ with the pressure loss curve and prolong the line ⑦ to the right on the water pressure drop axis (15 kPa).

WKH 250-2

Air temperature downstream of the water heating coils [°C]

5 10 15 20 25 30 35 40 45 50 55

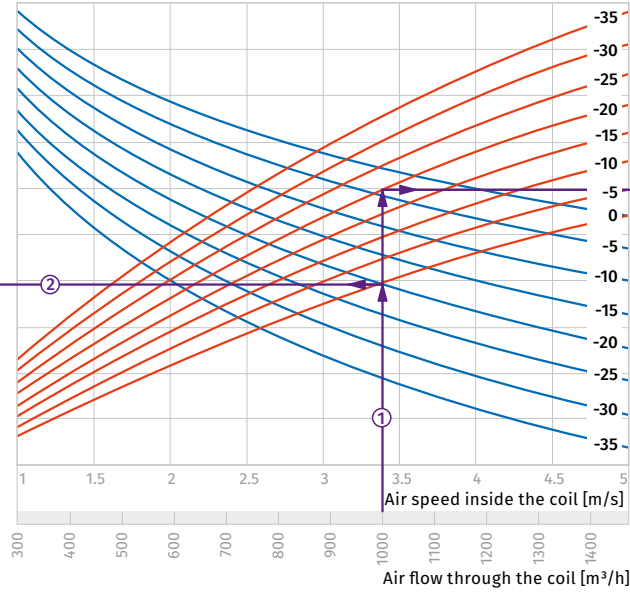
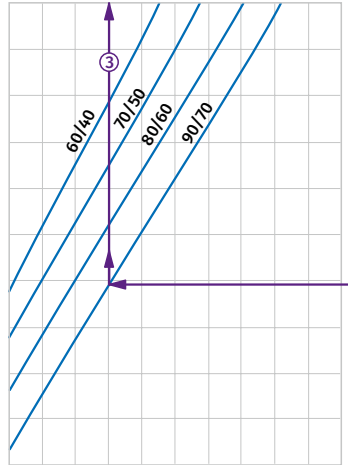

Coil heating capacity [kW]

2 4 6 8 10 12 14 16 18 20 22

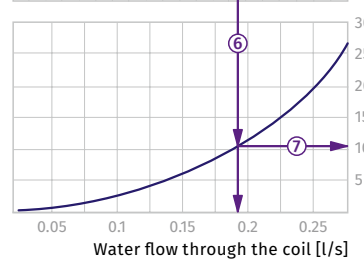
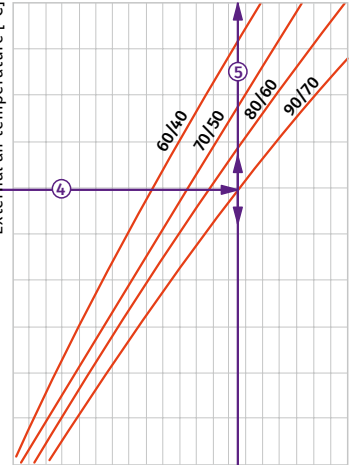

How to use water heater diagrams.

System Parameters: Air flow = 1000 m³/h.
Outside air temperature = -20 °C.
Water temperature (in/out) = +90/+70 °C.
The air flow is 1000 m³/h and the air speed in the heater is 3.4 m/s ①.

- To calculate the maximum air temperature find the intersection point of the air flow line ① with the rated outer temperature shown in blue line (e.g., -20 °C) and draw the line ② to the left until it crosses the water in/out temperature curve (e.g., +90/+70). From this point draw a vertical line to the supply air temperature downstream of the heater (+20 °C) ③.

- To calculate the heater power find the intersection point of the air flow ① with the rated winter temperature shown in red line (e.g., -20 °C) and draw the line ④ to the right until it crosses the water in/out temperature curve (e.g., +90/+70). From this point draw a vertical line to the heater power axis (15.5 kW) ⑤.

- To calculate the required water flow in the heater prolong this line ⑥ downwards to the water flow axis (0.19 l/s).
- To calculate the water pressure drop in the heater find the intersection point of the line ⑥ with the pressure loss curve and prolong the line ⑦ to the right on the water pressure drop axis (11.0 kPa).

WKH 250-4

Air temperature downstream of the water heating coils [°C]

15 20 25 30 35 40 45 50 55 60 65

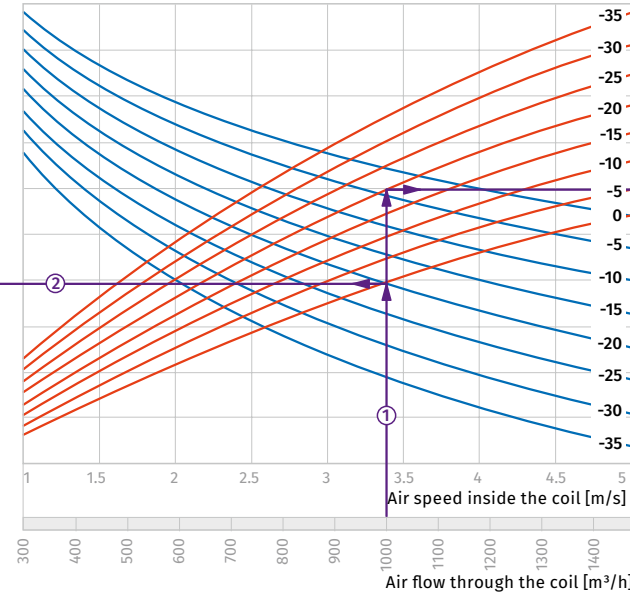
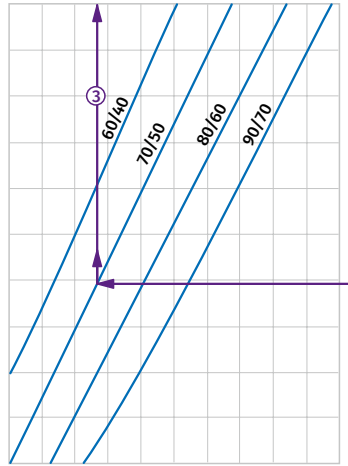

Coil heating capacity [kW]

0 4 8 12 16 20 24 28 32 36 40

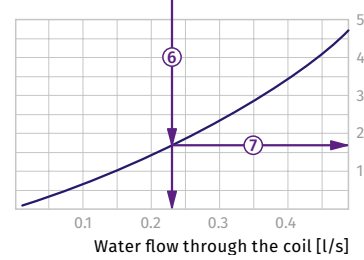
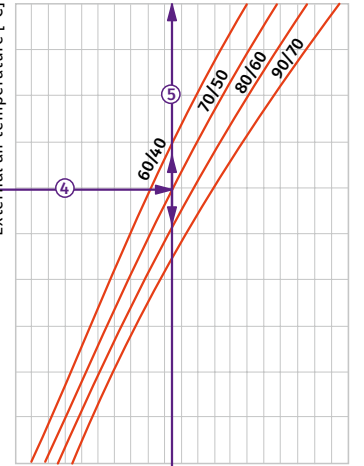

How to use water heater diagrams.

System Parameters: Air flow = 1000 m³/h.
Outside air temperature = -20 °C.
Water temperature (in/out) = +70/+50 °C.
The air flow is 1000 m³/h and the air speed in the heater is 3.4 m/s ①.

- To calculate the maximum air temperature find the intersection point of the air flow line ① with the rated outer temperature shown in blue line (e.g., -20 °C) and draw the line ② to the left until it crosses the water in/out temperature curve (e.g., +70/+50). From this point draw a vertical line to the supply air temperature downstream of the heater (+28 °C) ③.

- To calculate the heater power find the intersection point of the air flow ① with the rated winter temperature shown in red line (e.g., -20 °C) and draw the line ④ to the right until it crosses the water in/out temperature curve (e.g., +70/+50). From this point draw a vertical line to the heater power axis (19.0 kW) ⑤.

- To calculate the required water flow in the heater prolong this line ⑥ downwards to the water flow axis (0.23 l/s).
- To calculate the water pressure drop in the heater find the intersection point of the line ⑥ with the pressure loss curve and prolong the line ⑦ to the right on the water pressure drop axis (17.0 kPa).

WKH 315-2

Air temperature downstream of the water heating coils [°C]

5 10 15 20 25 30 35 40 45 50 55

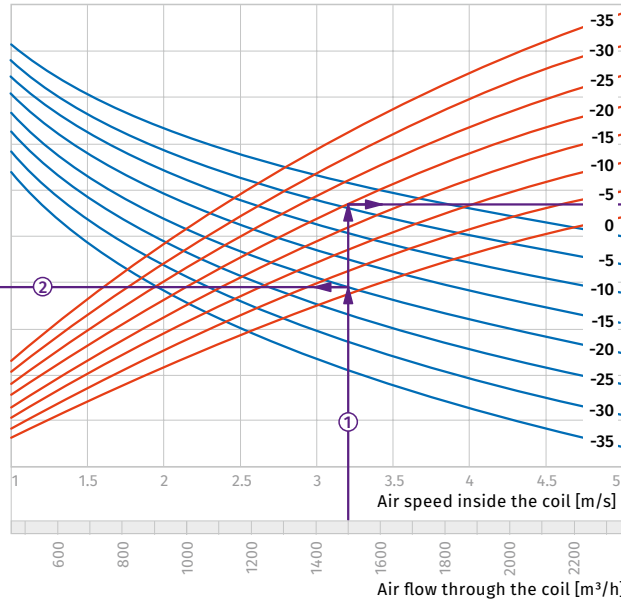
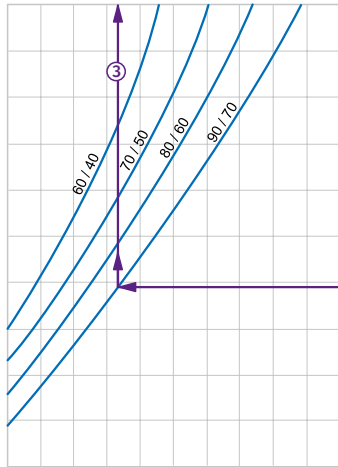

Coil heating capacity [kW]

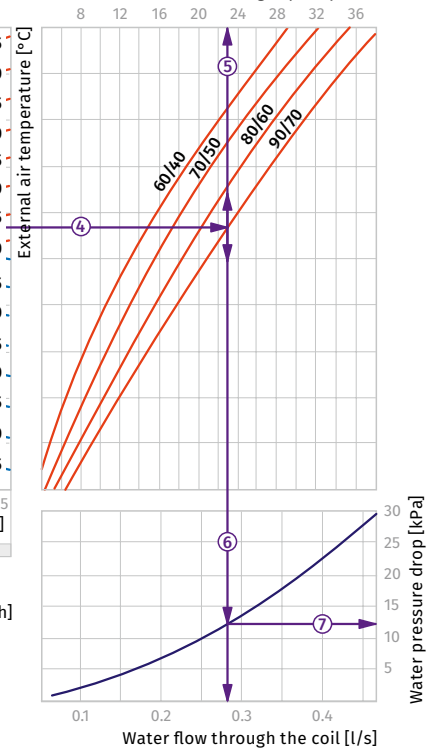

How to use water heater diagrams.

System Parameters: Air flow = 1500 m³/h.
Outside air temperature = -20 °C.
Water temperature (in/out) = +90/+70 °C.
The air flow is 1000 m³/h and the air speed in the heater is 3.2 m/s ①.

- To calculate the maximum air temperature find the intersection point of the air flow line ① with the rated outer temperature shown in blue line (e.g., -20 °C) and draw the line ② to the left until it crosses the water in/out temperature curve (e.g., +90/+70). From this point draw a vertical line to the supply air temperature downstream of the heater (+21 °C) ③.

- To calculate the heater power find the intersection point of the air flow ① with the rated winter temperature shown in red line (e.g., -20 °C) and draw the line ④ to the right until it crosses the water in/out temperature curve (e.g., +90/+70). From this point draw a vertical line to the heater power axis (23.0 kW) ⑤.

- To calculate the required water flow in the heater prolong this line ⑥ downwards to the water flow axis (0.28 l/s).
- To calculate the water pressure drop in the heater find the intersection point of the line ⑥ with the pressure loss curve and prolong the line ⑦ to the right on the water pressure drop axis (12.5 kPa).

WKH 315-4

Air temperature downstream of the water heating coils [°C]

15 20 25 30 35 40 45 50 55 60 65

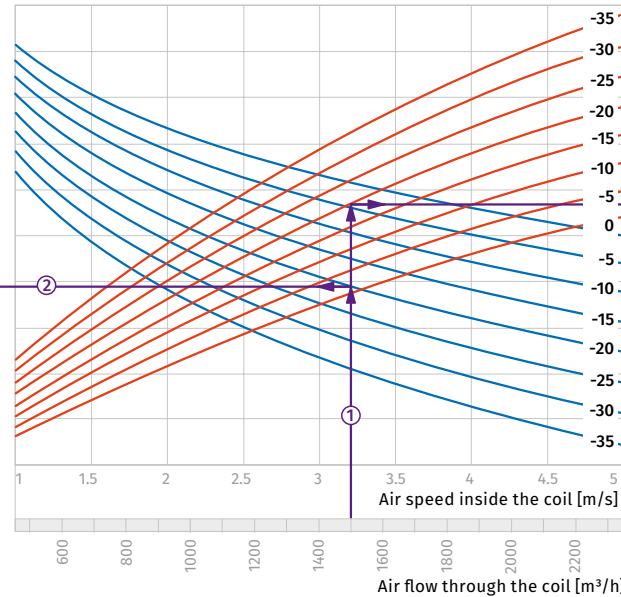
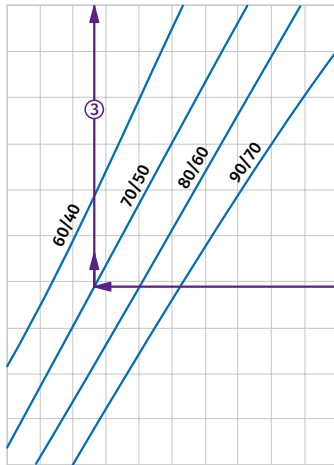

Coil heating capacity [kW]

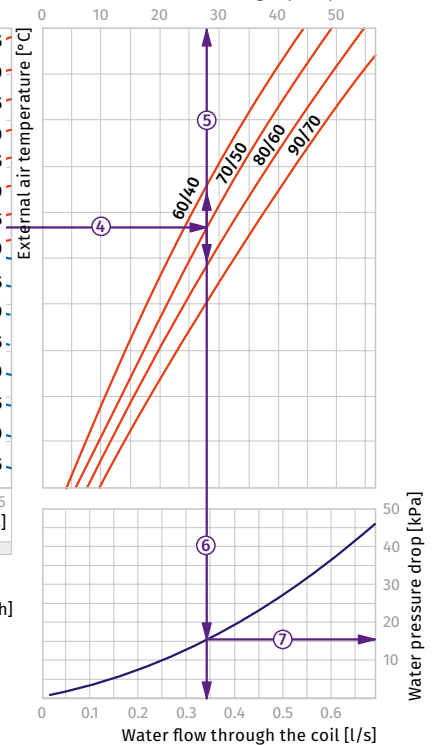

How to use water heater diagrams.

System Parameters: Air flow = 1500 m³/h.
Outside air temperature = -20 °C.
Water temperature (in/out) = +70/+50 °C.
The air flow is 1000 m³/h and the air speed in the heater is 3.2 m/s ①.

- To calculate the maximum air temperature find the intersection point of the air flow line ① with the rated outer temperature shown in blue line (e.g., -20 °C) and draw the line ② to the left until it crosses the water in/out temperature curve (e.g., +70/+50). From this point draw a vertical line to the supply air temperature downstream of the heater (+28 °C) ③.

- To calculate the heater power find the intersection point of the air flow ① with the rated winter temperature shown in red line (e.g., -20 °C) and draw the line ④ to the right until it crosses the water in/out temperature curve (e.g., +70/+50). From this point draw a vertical line to the heater power axis (28.0 kW) ⑤.

- To calculate the required water flow in the heater prolong this line ⑥ downwards to the water flow axis (0.34 l/s).
- To calculate the water pressure drop in the heater find the intersection point of the line ⑥ with the pressure loss curve and prolong the line ⑦ to the right on the water pressure drop axis (16.0 kPa).

KWK

Duct water cooling units for rectangular air ducts

Features

- Supply air cooling for ventilation systems in various premises.
- Suitable for installation into supply ventilation or into air handling units to provide air cooling.



Design

- Galvanized steel casing.
- The cooling elements are made of copper tubes and aluminum plates.
- Available in three-coil modifications and rated for maximum operating pressure 1.5 MPa (15 bar).
- Polypropylene droplet separator and drain pan for condensate drainage and removal included.
- Droplet separator is efficient at an air flow not exceeding 4 m/s.

Mounting

- Only horizontal mounting by means of flanged connection. Air evacuation and condensate drainage must be provided.
- Air filter installation upstream of the cooling unit to prevent the unit soiling.
- Installation position must ensure uniform air flow distribution in the section.
- Mounting upstream or downstream of the supply fan. The minimum air duct length downstream of the fan must be 1 m to ensure air flow stabilization.
- The maximum cooling capacity is attained if the cooling unit is connected on counter-flow basis. The attached charts are valid for counter-flow connection.
- If water is used as a cooling agent, the cooling unit is suitable for indoor use only with the ambient temperature not below 0 °C.
- If antifreezing solution, for example, ethylene glycol solution, is used as a cooling agent, the cooling unit is suitable for outdoor use as well.

- While mounting the cooling unit provide condensate drainage through the U-trap. The U-trap height must be selected with respect to the total fan pressure, refer to the table and diagram below.

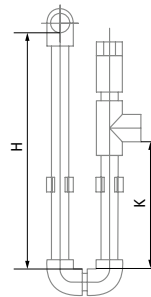

H [mm]	K [mm]	P [Pa]
100	55	600
200	105	1100
260	140	1400

H – U-trap height
K – drain height
P – total fan pressure

- For a proper and safe operation of the cooling unit it should be connected to a control system for integral control and automatic cooling capacity regulation.

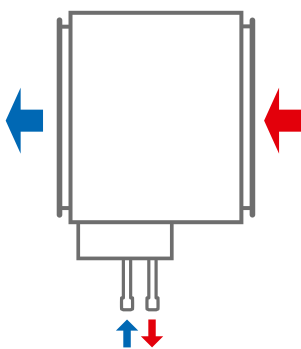

Counter air flow connection

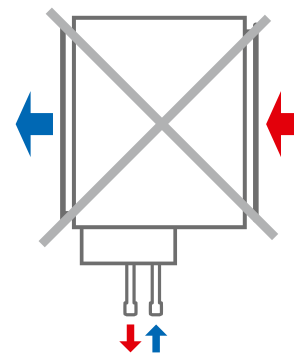

Air flow streamwise connection

Designation key

Series	Flange size (WxH) [cm]	Number of water (glycol) coil rows
KWK	40x20; 50x25; 50x30; 60x30; 60x35; 70x40; 80x50; 90x50; 100x50	3

Overall dimensions [mm]

Model	B	B1	B2	H	H1	H2	L	K
KWK 40x20-3	400	440	470	200	295	124	56	G 3/4"
KWK 50x25-3	500	540	570	250	345	188	45	G 3/4"
KWK 50x30-3	500	540	570	300	395	252	56	G 3/4"
KWK 60x30-3	600	640	670	300	395	252	56	G 3/4"
KWK 60x35-3	600	640	670	350	445	268	56	G 3/4"
KWK 70x40-3	700	740	770	400	495	314	56	G 3/4"
KWK 80x50-3	800	840	870	500	595	442	56	G 3/4"
KWK 90x50-3	900	940	970	500	595	442	56	G 3/4"
KWK 100x50-3	1000	1040	1070	500	595	442	56	G 1"

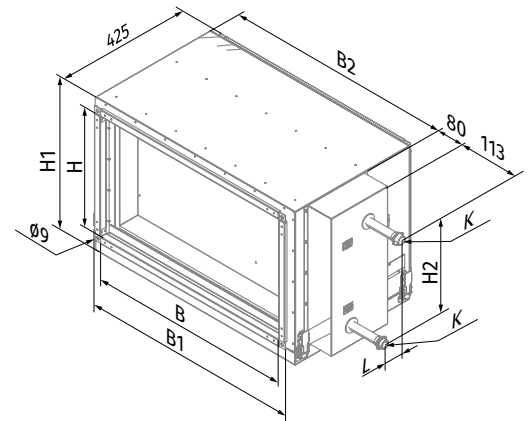

KWK

Pressure losses in water cooling coils

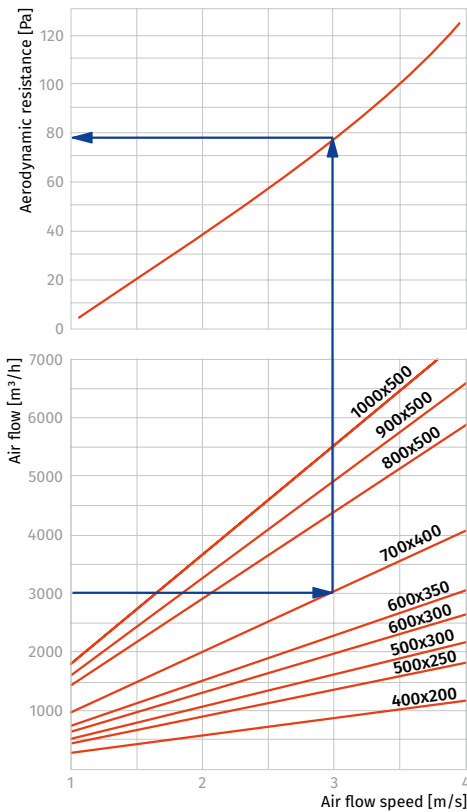

DX cooling unit calculation diagram

KWK 40x20-3

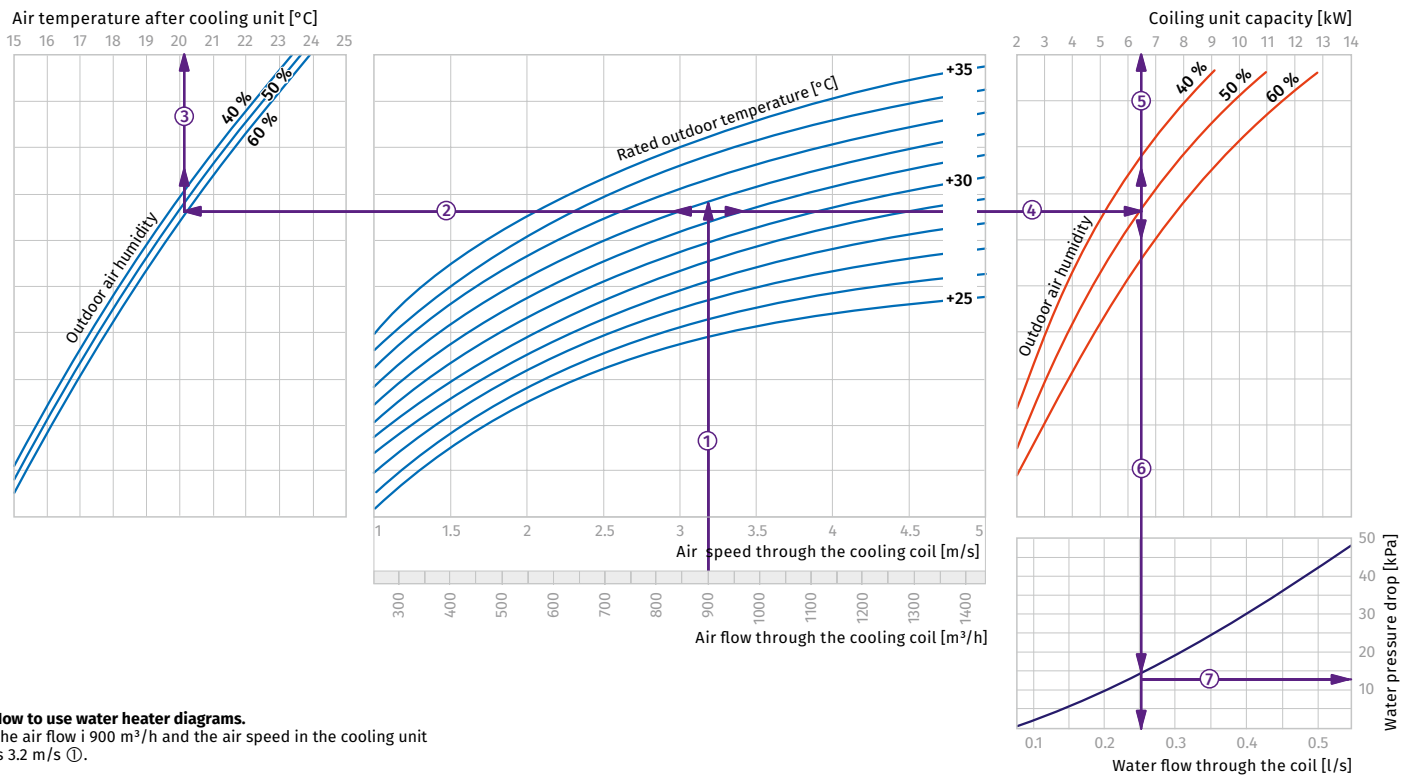

How to use water heater diagrams.

The air flow is 900 m³/h and the air speed in the cooling unit is 3.2 m/s ①.

- To calculate the coldest air temperature find the intersection point of the air flow line ① with the rated outer summer temperature shown in blue line (e.g., +32 °C) and draw the line ② to the left until it crosses the outdoor air humidity curve (e.g. 50 %). From this point draw a vertical line to the supply air temperature downstream of the cooling unit (+20.1 °C) ③.

- To calculate the power of the cooling unit find the intersection point of the air flow ① with the rated summer temperature (e.g., +32 °C) and draw the line ④ to the right until it crosses the air humidity curve (e.g., 50 %). From this point draw a vertical line to the cooling unit power axis (6.5 kW) ⑤.

- To calculate the required water flow in the cooling unit prolong this line ⑥ downwards to the water flow axis (0.26 l/s).
- To calculate the water pressure drop in the cooling unit find the intersection point of the line ⑥ with the pressure loss curve and prolong the line ⑦ to the right on the water pressure axis (15.0 kPa).

KWK 50x25-3

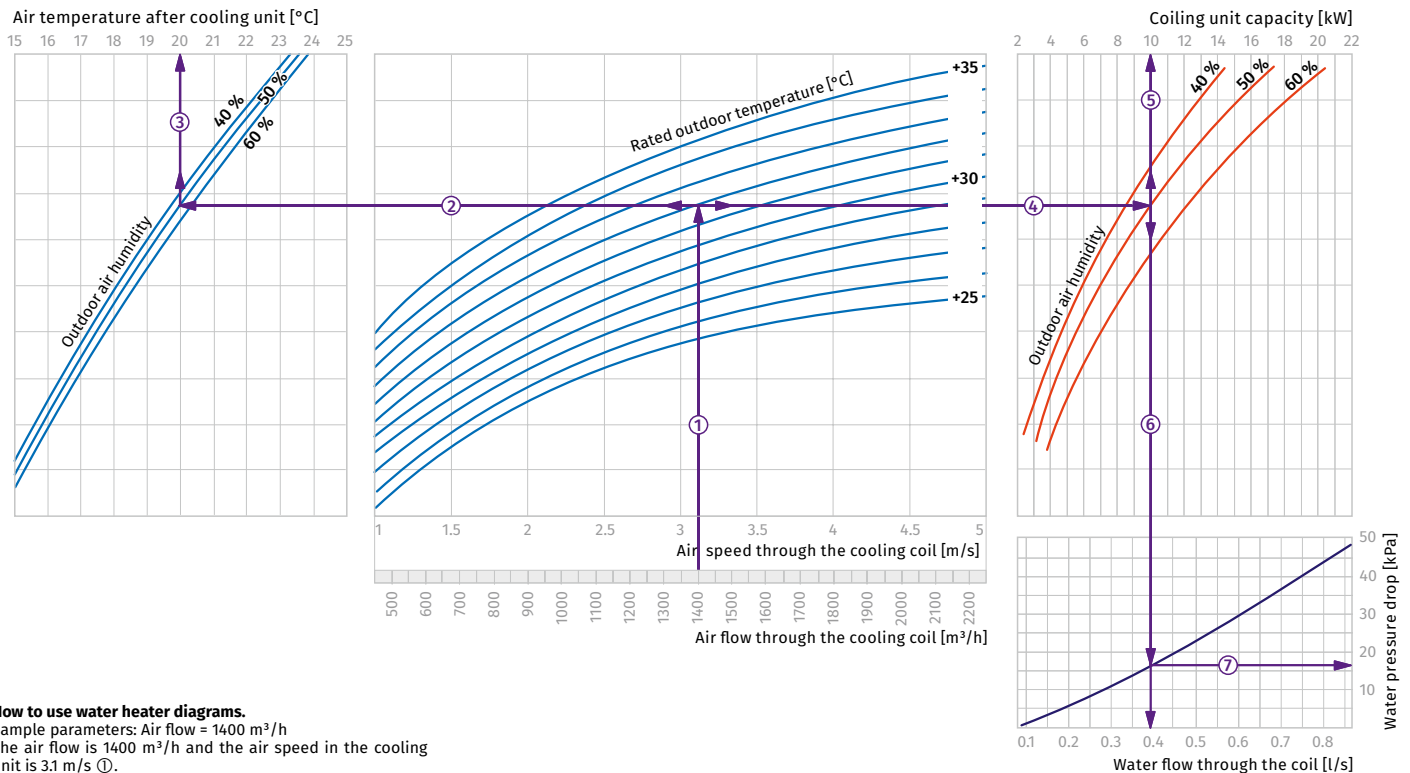

How to use water heater diagrams.

Sample parameters: Air flow = 1400 m³/h
The air flow is 1400 m³/h and the air speed in the cooling unit is 3.1 m/s ①.

- To calculate the coldest air temperature find the intersection point of the air flow line ① with the rated outer summer temperature shown in blue line (e.g., +32 °C) and draw the line ② to the left until it crosses the outdoor air humidity curve (e.g. 50 %). From this point draw a vertical line to the supply air temperature downstream of the cooling unit (+20 °C) ③.

- To calculate the power of the cooling unit find the intersection point of the air flow ① with the rated summer temperature (e.g., +32 °C) and draw the line ④ to the right until it crosses the air humidity curve (e.g., 50 %). From this point draw a vertical line to the cooling unit power axis (10.0 kW) ⑤.

- To calculate the required water flow in the cooling unit prolong this line ⑥ downwards to the water flow axis (0.4 l/s).
- To calculate the water pressure drop in the cooling unit find the intersection point of the line ⑥ with the pressure loss curve and prolong the line ⑦ to the right on the water pressure axis (17.0 kPa).

KWK 50x30-3

Air temperature after cooling unit [°C]

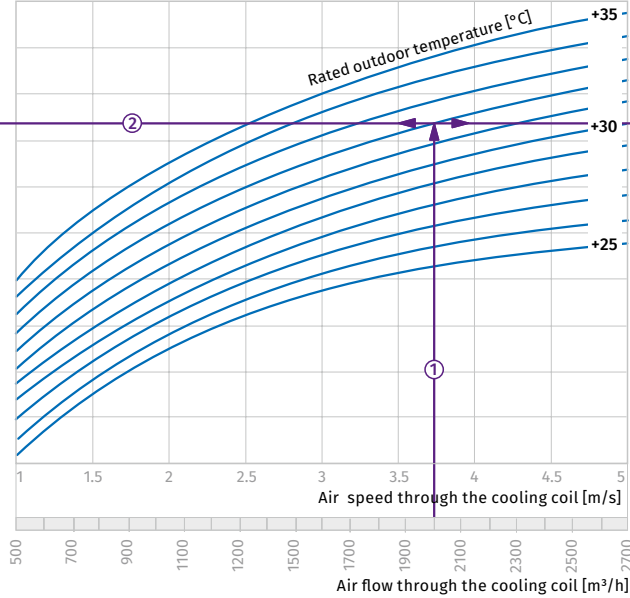
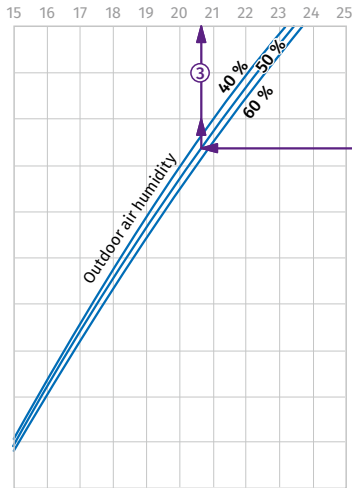

Coiling unit capacity [kW]

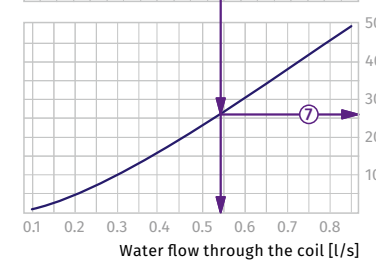
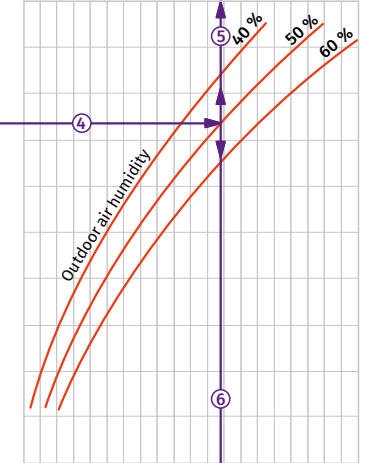

How to use water heater diagrams.

Sample parameters: Air flow = 2000 m³/h
The air flow is 2000 m³/h and the air speed in the cooling unit is 3.75 m/s ①.

- To calculate the coldest air temperature find the intersection point of the air flow line ① with the rated outer summer temperature shown in blue line (e.g., +32 °C) and draw the line ② to the left until it crosses the outdoor air humidity curve (e.g. 50 %). From this point draw a vertical line to the supply air temperature downstream of the cooling unit (+20.6 °C) ③.

- To calculate the power of the cooling unit find the intersection point of the air flow ① with the rated summer temperature (e.g., +32 °C) and draw the line ④ to the right until it crosses the air humidity curve (e.g., 50 %). From this point draw a vertical line to the cooling unit power axis (13.6 kW) ⑤.

- To calculate the required water flow in the cooling unit prolong this line ⑥ downwards to the water flow axis (0.54 l/s).
- To calculate the water pressure drop in the cooling unit find the intersection point of the line ⑥ with the pressure loss curve and prolong the line ⑦ to the right on the water pressure axis (27.0 kPa).

KWK 60x30-3

Air temperature after cooling unit [°C]

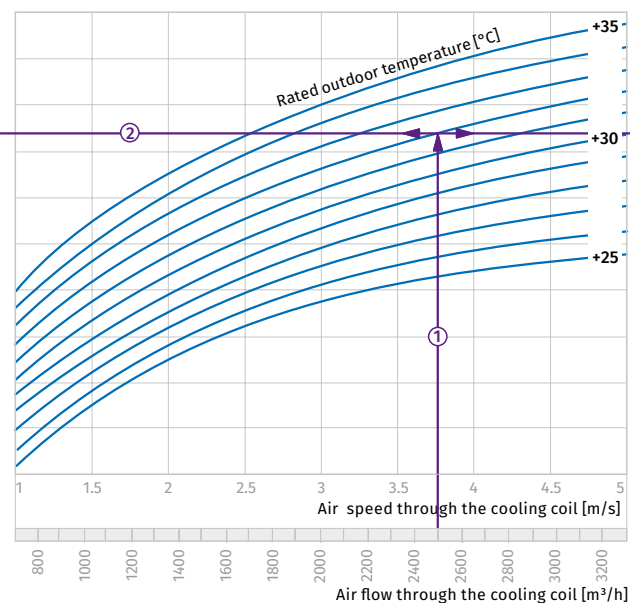
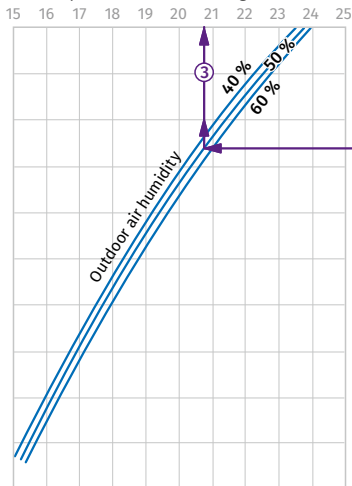

Coiling unit capacity [kW]

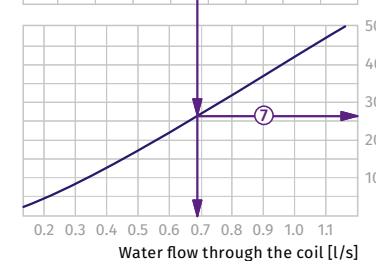
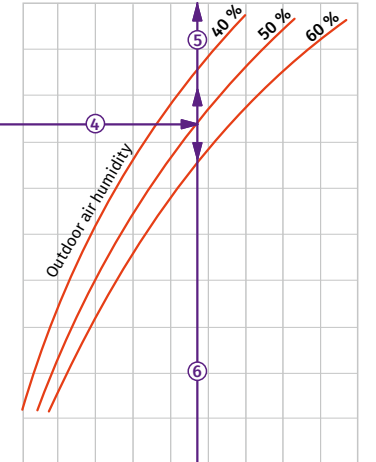

How to use water heater diagrams.

Sample parameters: Air flow = 2500 m³/h
The air flow is 2500 m³/h and the air speed in the cooling unit is 3.75 m/s ①.

- To calculate the coldest air temperature find the intersection point of the air flow line ① with the rated outer summer temperature shown in blue line (e.g., +32 °C) and draw the line ② to the left until it crosses the outdoor air humidity curve (e.g. 50 %). From this point draw a vertical line to the supply air temperature downstream of the cooling unit (+20.7 °C) ③.

- To calculate the power of the cooling unit find the intersection point of the air flow ① with the rated summer temperature (e.g., +32 °C) and draw the line ④ to the right until it crosses the air humidity curve (e.g., 50 %). From this point draw a vertical line to the cooling unit power axis (17.0 kW) ⑤.

- To calculate the required water flow in the cooling unit prolong this line ⑥ downwards to the water flow axis (0.68 l/s).
- To calculate the water pressure drop in the cooling unit find the intersection point of the line ⑥ with the pressure loss curve and prolong the line ⑦ to the right on the water pressure axis (27.0 kPa).

KWK 60x35-3

Air temperature after cooling unit [°C]

15 16 17 18 19 20 21 22 23 24 25

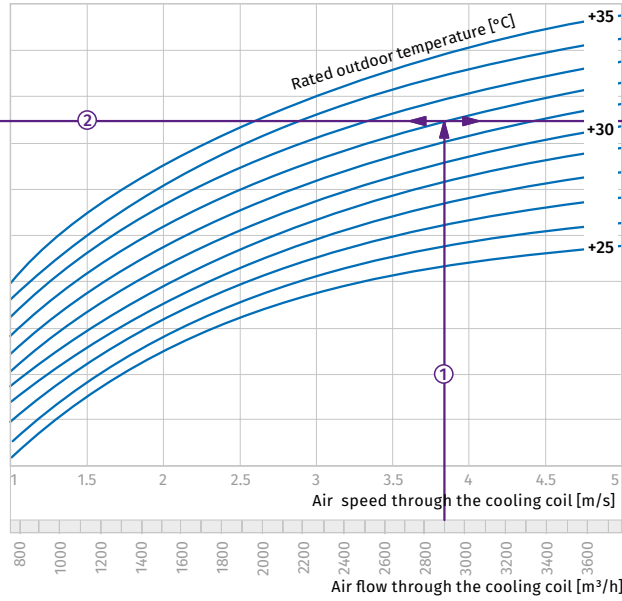
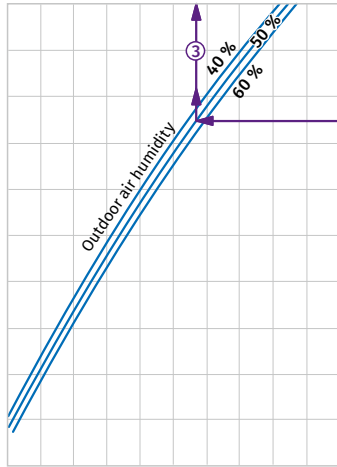

Coiling unit capacity [kW]

3 6 9 12 15 18 21 24 27 30 33

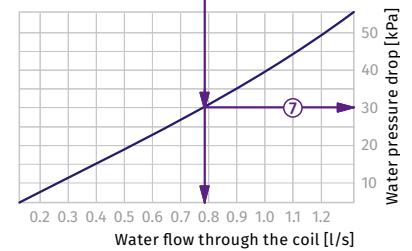
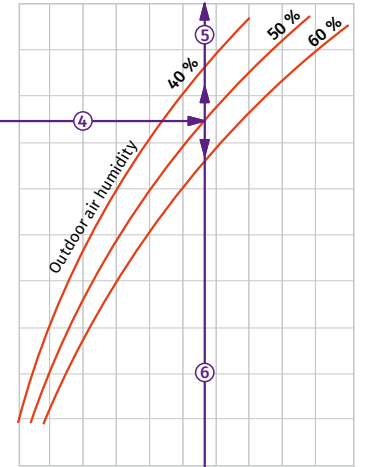

How to use water heater diagrams.

Sample parameters: Air flow = 2850 m³/h
The air flow is 2850 m³/h and the air speed in the cooling unit is 3.85 m/s ①.

- To calculate the coldest air temperature find the intersection point of the air flow line ① with the rated outer summer temperature shown in blue line (e.g., +32 °C) and draw the line ② to the left until it crosses the outdoor air humidity curve (e.g. 50 %). From this point draw a vertical line to the supply air temperature downstream of the cooling unit (+20.7 °C) ③.

- To calculate the power of the cooling unit find the intersection point of the air flow ① with the rated summer temperature (e.g., +32 °C) and draw the line ④ to the right until it crosses the air humidity curve (e.g., 50 %). From this point draw a vertical line to the cooling unit power axis (19.8 kW) ⑤.

- To calculate the required water flow in the cooling unit prolong this line ⑥ downwards to the water flow axis (0.78 l/s).
- To calculate the water pressure drop in the cooling unit find the intersection point of the line ⑥ with the pressure loss curve and prolong the line ⑦ to the right on the water pressure axis (30 kPa).

COOLERS

KWK 70x40-3

Air temperature after cooling unit [°C]

15 16 17 18 19 20 21 22 23 24 25

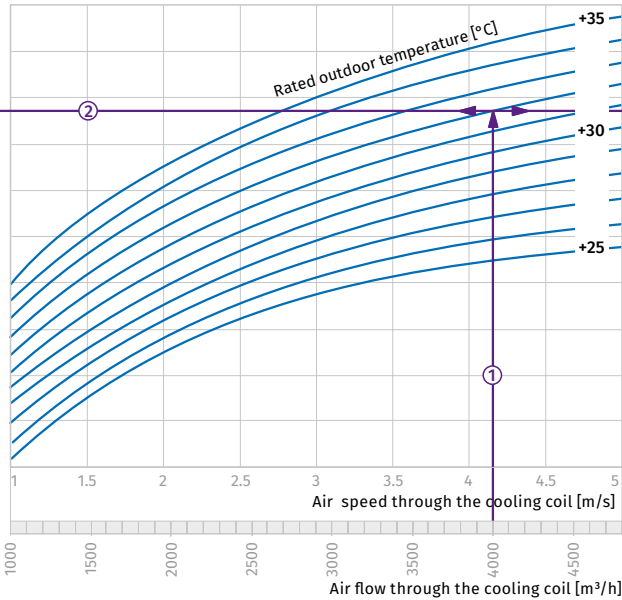
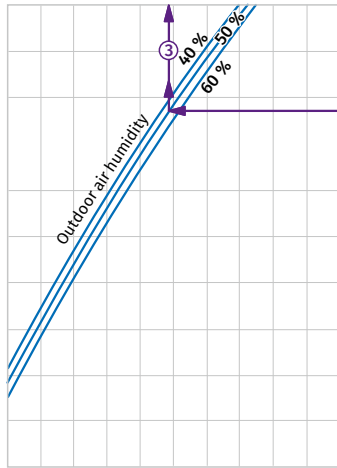

Coiling unit capacity [kW]

5 10 15 20 25 30 35 40 45

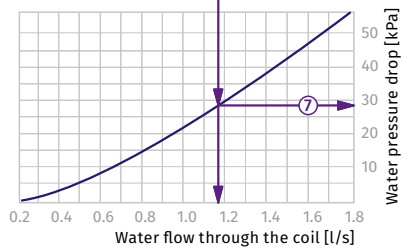
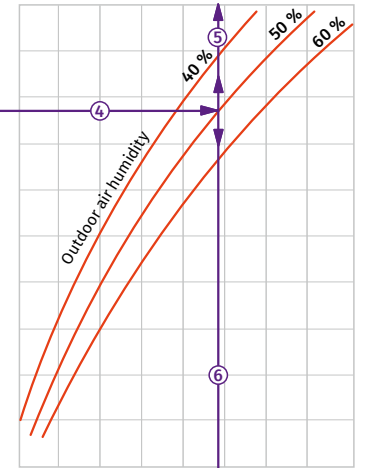

How to use water heater diagrams.

Sample parameters: Air flow = 4000 m³/h
The air flow is 4000 m³/h and the air speed in the cooling unit is 4.15 m/s ①.

- To calculate the coldest air temperature find the intersection point of the air flow line ① with the rated outer summer temperature shown in blue line (e.g., +32 °C) and draw the line ② to the left until it crosses the outdoor air humidity curve (e.g. 50 %). From this point draw a vertical line to the supply air temperature downstream of the cooling unit (+19.8 °C) ③.

- To calculate the power of the cooling unit find the intersection point of the air flow ① with the rated summer temperature (e.g., +32 °C) and draw the line ④ to the right until it crosses the air humidity curve (e.g., 50 %). From this point draw a vertical line to the cooling unit power axis (28.5 kW) ⑤.

- To calculate the required water flow in the cooling unit prolong this line ⑥ downwards to the water flow axis (1.14 l/s).
- To calculate the water pressure drop in the cooling unit find the intersection point of the line ⑥ with the pressure loss curve and prolong the line ⑦ to the right on the water pressure axis (28 kPa).

KWK 80x50-3

Air temperature after cooling unit [°C]

15 16 17 18 19 20 21 22 23 24 25

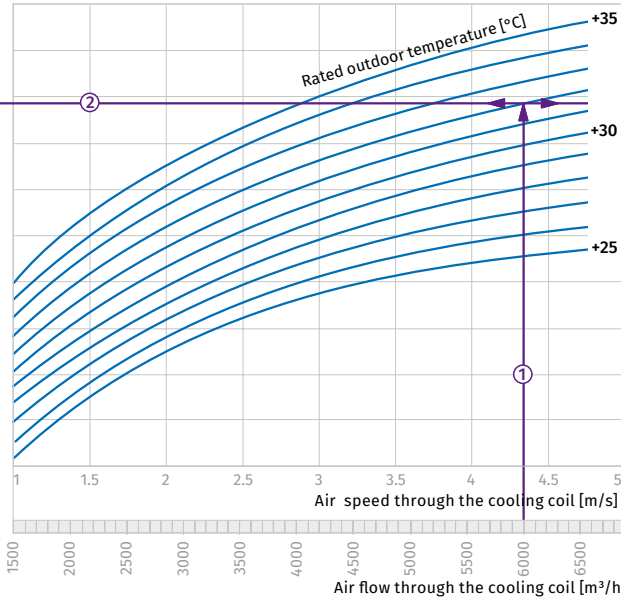
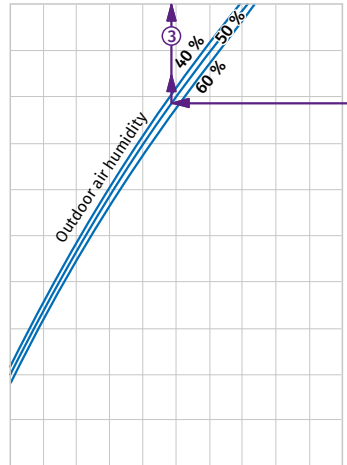

Coiling unit capacity [kW]

5 10 15 20 25 30 35 40 45 50 55 60

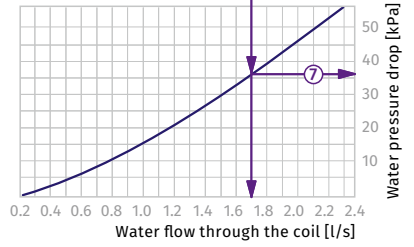
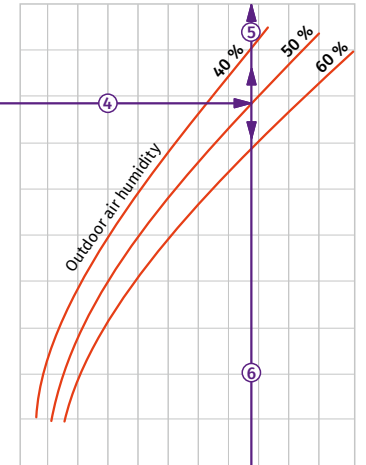

How to use water heater diagrams.

Sample parameters: Air flow = 6000 m³/h
The air flow is 6000 m³/h and the air speed in the cooling unit is 4.35 m/s ①.

- To calculate the coldest air temperature find the intersection point of the air flow line ① with the rated outer summer temperature shown in blue line (e.g., +32 °C) and draw the line ② to the left until it crosses the outdoor air humidity curve (e.g. 50 %). From this point draw a vertical line to the supply air temperature downstream of the cooling unit (+19.9 °C) ③.

- To calculate the power of the cooling unit find the intersection point of the air flow ① with the rated summer temperature (e.g., +32 °C) and draw the line ④ to the right until it crosses the air humidity curve (e.g., 50 %). From this point draw a vertical line to the cooling unit power axis (43 kW) ⑤.

- To calculate the required water flow in the cooling unit prolong this line ⑥ downwards to the water flow axis (1.7 l/s).
- To calculate the water pressure drop in the cooling unit find the intersection point of the line ⑥ with the pressure loss curve and prolong the line ⑦ to the right on the water pressure axis (36 kPa).

KWK 90x50-3

Air temperature after cooling unit [°C]

15 16 17 18 19 20 21 22 23 24 25

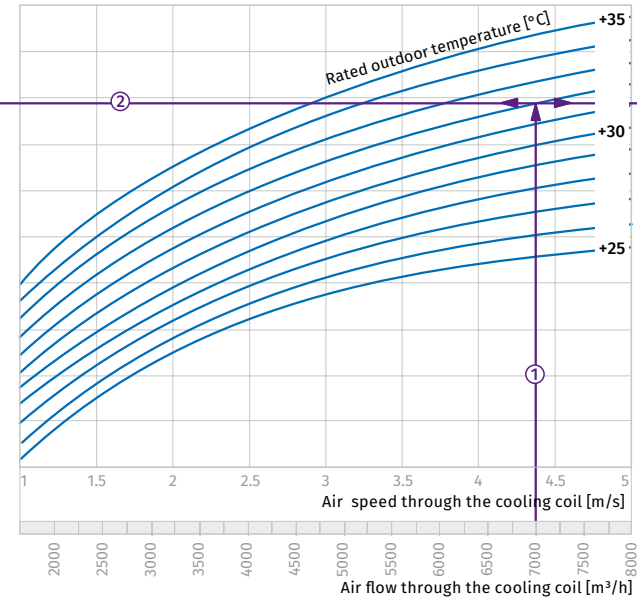
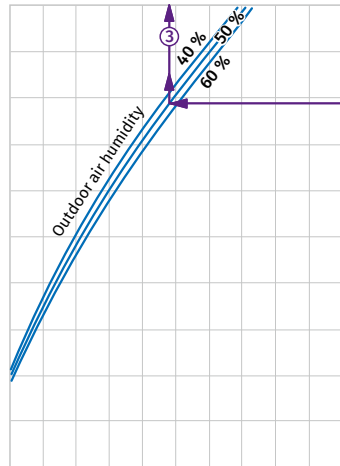

Coiling unit capacity [kW]

10 20 30 40 50 60 70

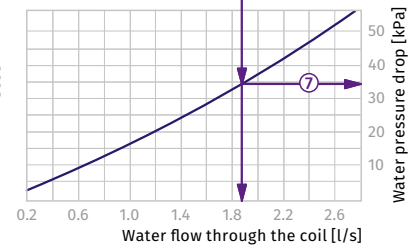
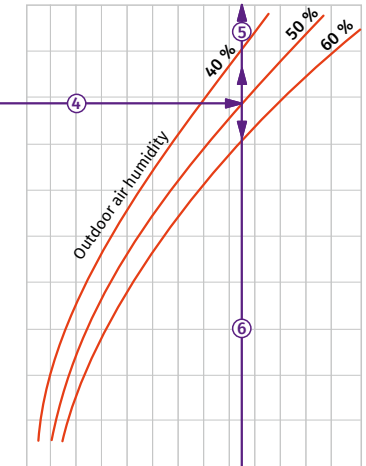

How to use water heater diagrams.

Sample parameters: Air flow = 7000 m³/h
The air flow is 7000 m³/h and the air speed in the cooling unit is 4.4 m/s ①.

- To calculate the coldest air temperature find the intersection point of the air flow line ① with the rated outer summer temperature shown in blue line (e.g., +32 °C) and draw the line ② to the left until it crosses the outdoor air humidity curve (e.g. 50 %). From this point draw a vertical line to the supply air temperature downstream of the cooling unit (+19.7 °C) ③.

- To calculate the power of the cooling unit find the intersection point of the air flow ① with the rated summer temperature (e.g., +32 °C) and draw the line ④ to the right until it crosses the air humidity curve (e.g., 50 %). From this point draw a vertical line to the cooling unit power axis (47 kW) ⑤.

- To calculate the required water flow in the cooling unit prolong this line ⑥ downwards to the water flow axis (1.9 l/s).
- To calculate the water pressure drop in the cooling unit find the intersection point of the line ⑥ with the pressure loss curve and prolong the line ⑦ to the right on the water pressure axis (34 kPa).

KWK 100x50-3

Air temperature after cooling unit [°C]

15 16 17 18 19 20 21 22 23 24 25

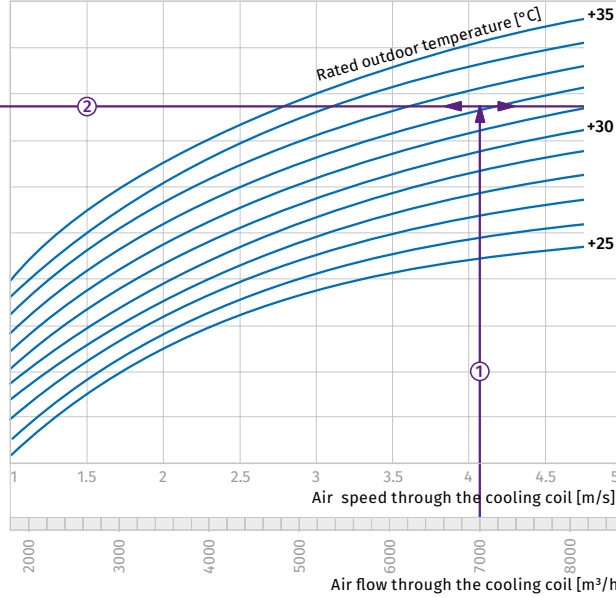
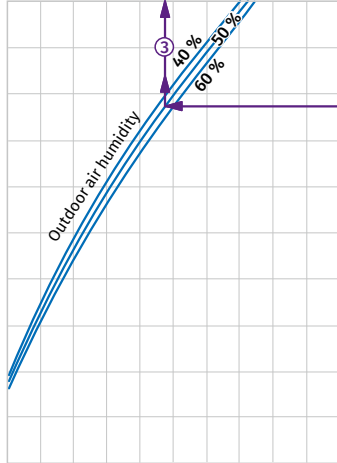

Coiling unit capacity [kW]

10 20 30 40 50 60 70 80

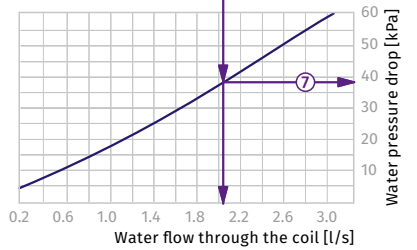
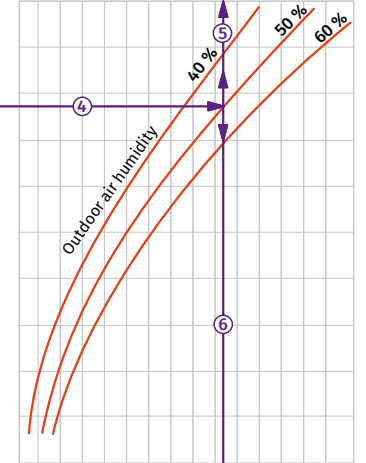

How to use water heater diagrams.

Sample parameters: Air flow = 7000 m³/h

The air flow is 7000 m³/h and the air speed in the cooling unit is 4.1 m/s ①.

- To calculate the coldest air temperature find the intersection point of the air flow line ① with the rated outer summer temperature shown in blue line (e.g., +32 °C) and draw the line ② to the left until it crosses the outdoor air humidity curve (e.g. 50 %). From this point draw a vertical line to the supply air temperature downstream of the cooling unit (+19.6 °C) ③.

- To calculate the power of the cooling unit find the intersection point of the air flow ① with the rated summer temperature (e.g., +32 °C) and draw the line ④ to the right until it crosses the air humidity curve (e.g., 50 %). From this point draw a vertical line to the cooling unit power axis (52 kW) ⑤.

- To calculate the required water flow in the cooling unit prolong this line ⑥ downwards to the water flow axis (2.05 l/s).
- To calculate the water pressure drop in the cooling unit find the intersection point of the line ⑥ with the pressure loss curve and prolong the line ⑦ to the right on the water pressure axis (37 kPa).

KFK

Duct DX cooling units for rectangular air ducts

Features

- Supply air cooling for ventilation systems in various premises.
- Suitable for installation into supply or air handling units to provide air cooling.



Design

- Galvanized steel casing.
- The cooling elements are made of copper tubes and aluminum plates.
- Available in three-coil modifications and rated for operation with R123, R134a, R152a, R404a, R407c, R410a, R507, R12, R22 refrigerants.
- Polypropylene droplet separator and drain pan for condensate drainage and removal included.
- Droplet separator operates efficiently at air flow below 4 m/s.

Mounting

- Only horizontal mounting by means of flanged connection. Condensate drainage must be provided.
- Air filter must be installed upstream of the cooling unit to prevent the unit soiling.
- Mounting position must ensure uniform air flow distribution through the entire cross section.
- Installation upstream or downstream of the supply fan. The minimum air duct length downstream of the fan must be 1 m to ensure air flow stabilization.
- The maximum cooling capacity is attained if the cooling unit is connected on counter-flow basis. The attached charts are valid for counter-flow connection.

- While mounting the cooling unit provide condensate drainage through the U-trap. The U-trap height must be selected with respect to the total fan pressure, refer to the table and diagram below.

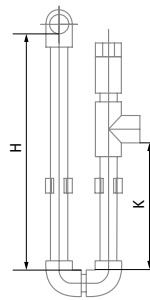

H [mm]	K [mm]	P [Pa]
100	55	600
200	105	1100
260	140	1400

H – U-trap height
K – drainage height
P – total fan pressure

- For a proper and safe operation of the cooling unit it should be connected to a control system for integral control and automatic cooling capacity regulation.

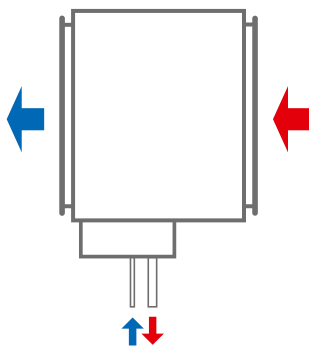

Counter air flow connection

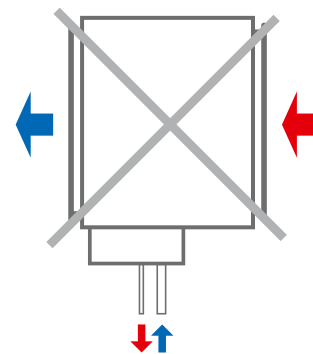

Air flow streamwise connection

Designation key

Series	Flange size (WxH) [cm]	Number of water (glycol) coil rows
KFK	40x20; 50x25; 50x30; 60x30; 60x35; 70x40; 80x50; 90x50; 100x50	3

Overall dimensions [mm]

Model	D	D1	B	B1	B2	H	H1	H2	L
KFK 40x20-3	12	22	400	440	470	200	295	103	44
KFK 50x25-3	12	22	500	540	570	250	345	155	44
KFK 50x30-3	12	22	500	540	570	300	395	210	33
KFK 60x30-3	18	28	600	640	670	300	395	199	44
KFK 60x35-3	18	28	600	640	670	350	445	199	44
KFK 70x40-3	22	28	700	740	770	400	495	224	44
KFK 80x50-3	22	28	800	840	870	500	595	340	44
KFK 90x50-3	22	28	900	940	970	500	595	340	44
KFK 100x50-3	22	28	1000	1040	1070	500	595	325	44

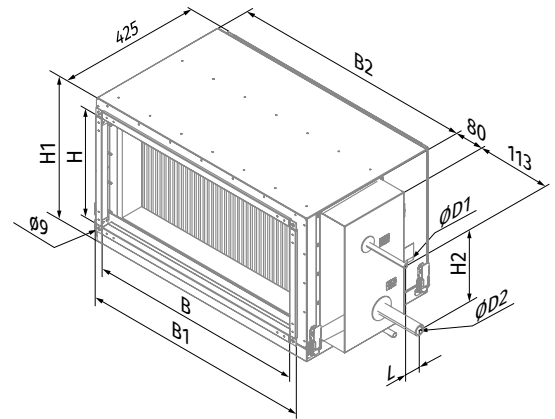

KFK

Air pressure losses in DX cooling coils

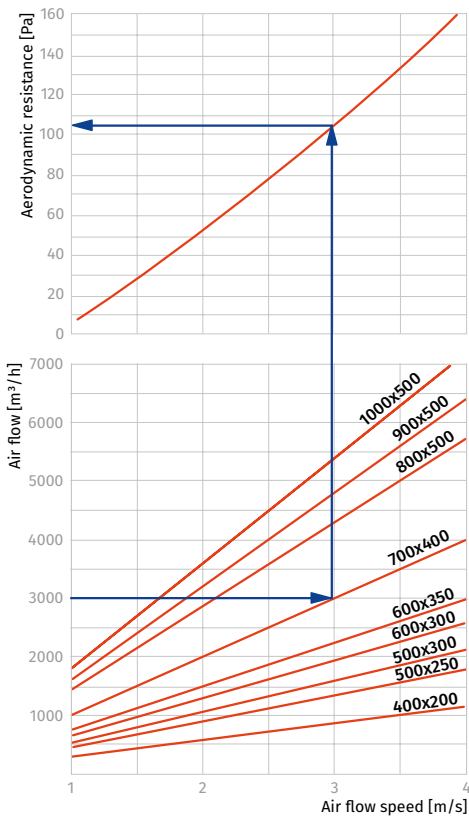

Water cooling unit calculation diagram

KFK 40x20-3

Air temperature after cooling unit [°C]

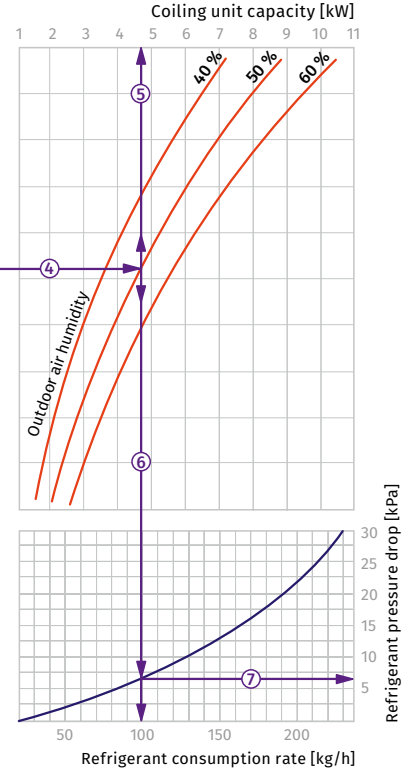
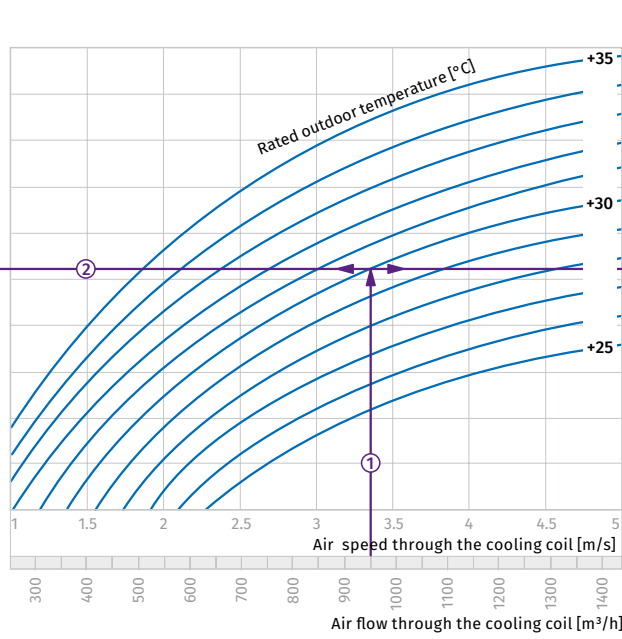
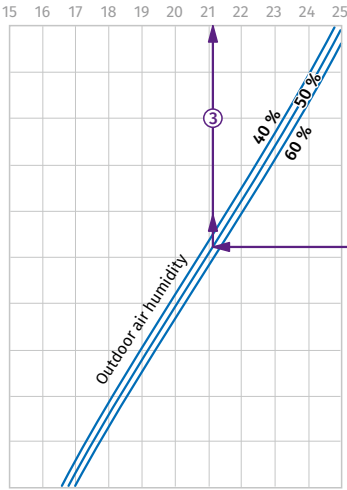

How to use water heater diagrams.

The air flow is 900 m³/h and the air speed in the cooling unit is 3.2 m/s ①.

- To calculate the coldest air temperature find the intersection point of the air flow line ① with the rated outdoor summer temperature shown in blue line (e.g., +32 °C) and draw the line ② to the left until it crosses the outdoor air humidity curve (e.g. 50 %). From this point draw a vertical line to the supply air temperature downstream of the cooling unit (+20.1 °C) ③.

- To calculate the power of the cooling unit find the intersection point of the air flow ① with the rated summer temperature (e.g., +32 °C) and draw the line ④ to the right until it crosses the air humidity curve (e.g., 50 %). From this point draw a vertical line to the cooling unit power axis (6.5 kW) ⑤.

- To define the necessary refrigerant flow through the cooling unit drop a perpendicular ⑥ on the axis which corresponds to refrigerant flow through the cooling unit (100 kg/h).
- To define refrigerant pressure drop in the cooling unit find the intersection point of line ⑥ with the pressure drop chart and draw a perpendicular ⑦ to the right until it crosses the refrigerant pressure axis (6.5 kPa).

COOLERS

KFK 50x25-3

Air temperature after cooling unit [°C]

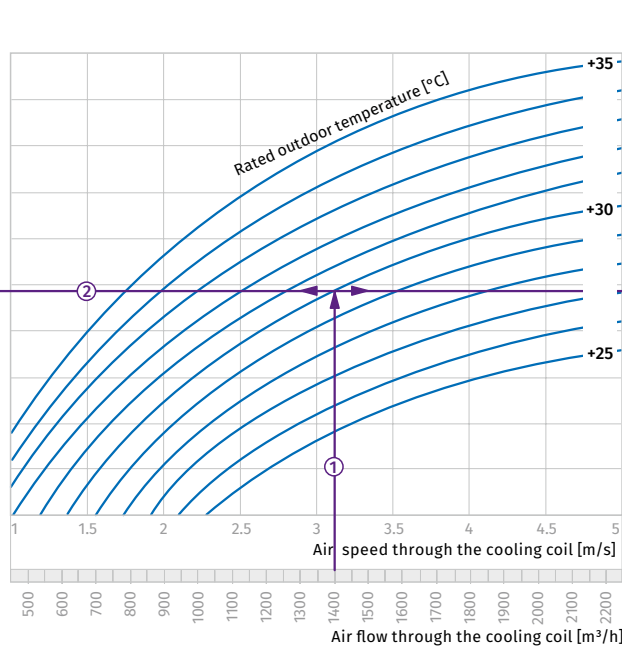
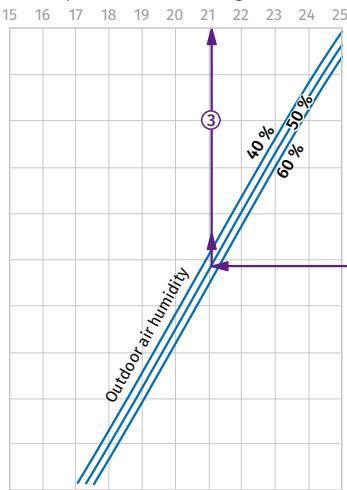

How to use water heater diagrams.

The air flow is 1400 m³/h and the air speed in the cooling unit is 3.1 m/s ①.

- To calculate the coldest air temperature find the intersection point of the air flow line ① with the rated outdoor summer temperature shown in blue line (e.g., +32 °C) and draw the line ② to the left until it crosses the outdoor air humidity curve (e.g. 50 %). From this point draw a vertical line to the supply air temperature downstream of the cooling unit (+20 °C) ③.

- To calculate the power of the cooling unit find the intersection point of the air flow ① with the rated summer temperature (e.g., +32 °C) and draw the line ④ to the right until it crosses the air humidity curve (e.g., 50 %). From this point draw a vertical line to the cooling unit power axis (10.0 kW) ⑤.

- To define the necessary refrigerant flow through the cooling unit drop a perpendicular ⑥ on the axis which corresponds to refrigerant flow through the cooling unit (152 kg/h).
- To define refrigerant pressure drop in the cooling unit find the intersection point of line ⑥ with the pressure drop chart and draw a perpendicular ⑦ to the right until it crosses the refrigerant pressure axis (7.5 kPa).

KFK 50x30-3

Air temperature after cooling unit [°C]

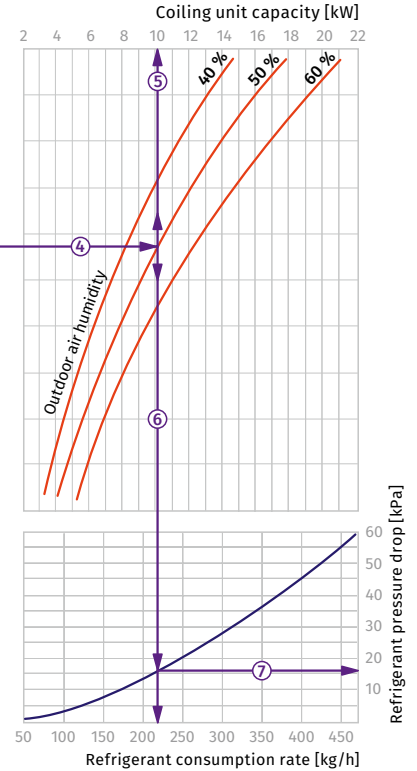
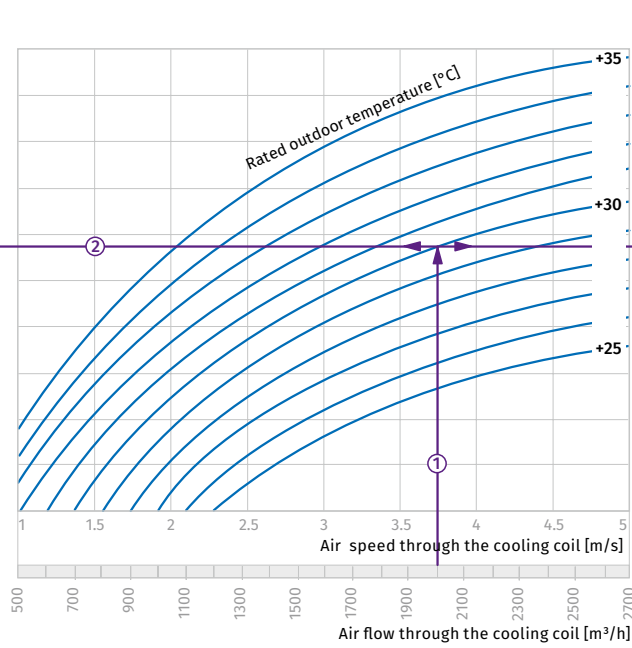
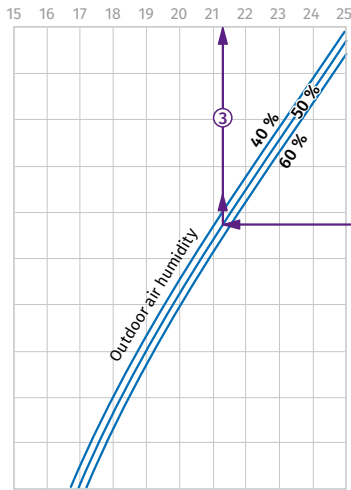

How to use water heater diagrams.

The air flow is 2000 m³/h and the air speed in the cooling unit is 3.75 m/s ①.

- To calculate the coldest air temperature find the intersection point of the air flow line ① with the rated outer summer temperature shown in blue line (e.g., +32 °C) and draw the line ② to the left until it crosses the outdoor air humidity curve (e.g. 50 %). From this point draw a vertical line to the supply air temperature downstream of the cooling unit (+20.6 °C) ③.

- To calculate the power of the cooling unit find the intersection point of the air flow ① with the rated summer temperature (e.g., +32 °C) and draw the line ④ to the right until it crosses the air humidity curve (e.g., 50 %). From this point draw a vertical line to the cooling unit power axis (13.6 kW) ⑤.

- To define the necessary refrigerant flow through the cooling unit drop a perpendicular ⑥ on the axis which corresponds to refrigerant flow through the cooling unit (215 kg/h).
- To define refrigerant pressure drop in the cooling unit find the intersection point of line ⑥ with the pressure drop chart and draw a perpendicular ⑦ to the right until it crosses the refrigerant pressure axis (16.0 kPa).

KFK 60x30-3

Air temperature after cooling unit [°C]

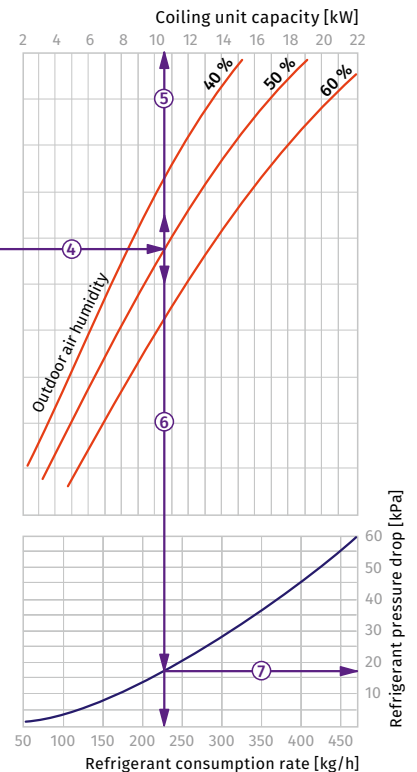
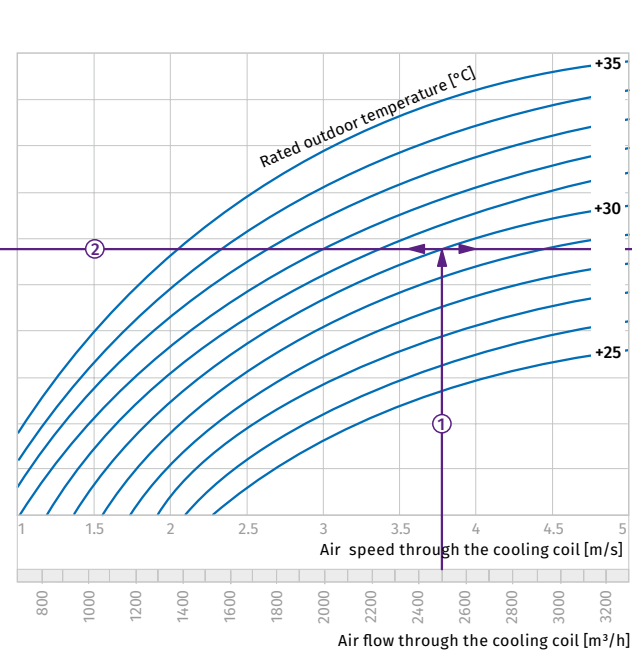
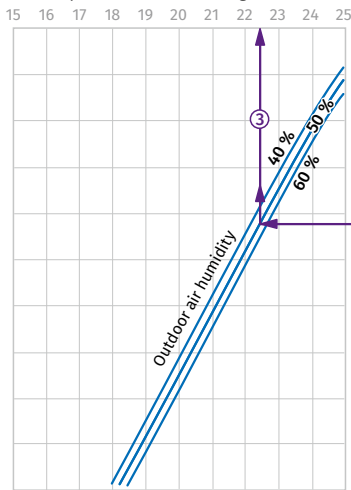

How to use water heater diagrams.

The air flow is 2500 m³/h and the air speed in the cooling unit is 3.75 m/s ①.

- To calculate the coldest air temperature find the intersection point of the air flow line ① with the rated outer summer temperature shown in blue line (e.g., +32 °C) and draw the line ② to the left until it crosses the outdoor air humidity curve (e.g. 50 %). From this point draw a vertical line to the supply air temperature downstream of the cooling unit (+20.7 °C) ③.

- To calculate the power of the cooling unit find the intersection point of the air flow ① with the rated summer temperature (e.g., +32 °C) and draw the line ④ to the right until it crosses the air humidity curve (e.g., 50 %). From this point draw a vertical line to the cooling unit power axis (17.0 kW) ⑤.

- To define the necessary refrigerant flow through the cooling unit drop a perpendicular ⑥ on the axis which corresponds to refrigerant flow through the cooling unit (225 kg/h).
- To define refrigerant pressure drop in the cooling unit find the intersection point of line ⑥ with the pressure drop chart and draw a perpendicular ⑦ to the right until it crosses the refrigerant pressure axis (17 kPa).

KFK 60x35-3

Air temperature after cooling unit [°C]

15 16 17 18 19 20 21 22 23 24 25

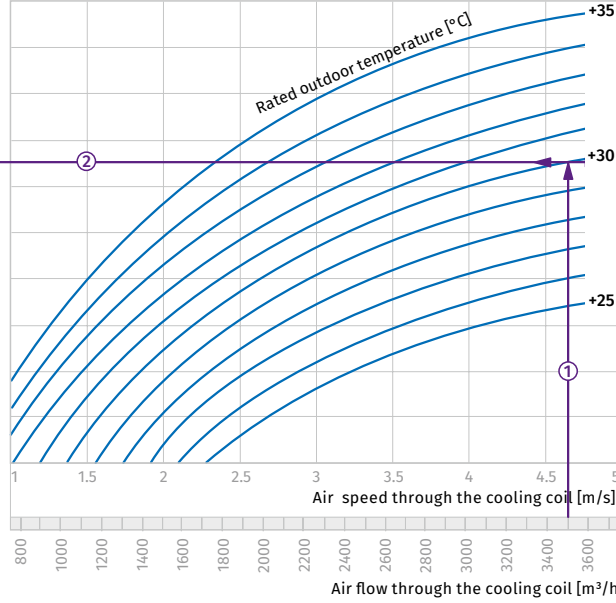

Coiling unit capacity [kW]

3 6 9 12 15 18 21 24 27

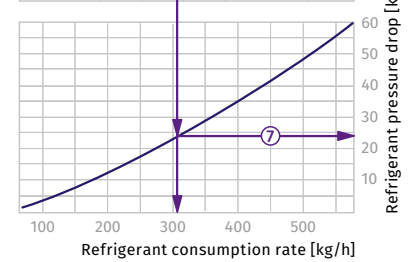
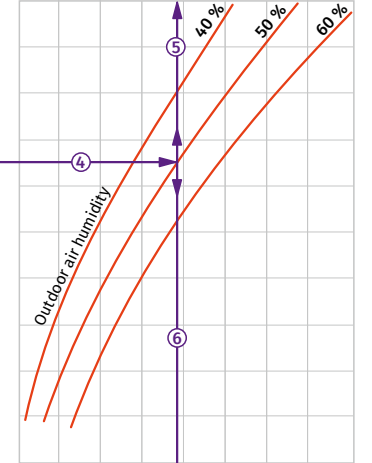

How to use water heater diagrams.

The air flow is 2850 m³/h and the air speed in the cooling unit is 3.85 m/s ①.

- To calculate the coldest air temperature find the intersection point of the air flow line ① with the rated outer summer temperature shown in blue line (e.g., +32 °C) and draw the line ② to the left until it crosses the outdoor air humidity curve (e.g. 50 %). From this point draw a vertical line to the supply air temperature downstream of the cooling unit (+20.7 °C) ③.

- To calculate the power of the cooling unit find the intersection point of the air flow ① with the rated summer temperature (e.g., +32 °C) and draw the line ④ to the right until it crosses the air humidity curve (e.g., 50 %). From this point draw a vertical line to the cooling unit power axis (19.8 kW).

- To define the necessary refrigerant flow through the cooling unit drop a perpendicular ⑥ on the axis which corresponds to refrigerant flow through the cooling unit (310 kg/h).
- To define refrigerant pressure drop in the cooling unit find the intersection point of line ⑥ with the pressure drop chart and draw a perpendicular ⑦ to the right until it crosses the refrigerant pressure axis (24.0 kPa).

COOLERS

KFK 70x40-3

Air temperature after cooling unit [°C]

15 16 17 18 19 20 21 22 23 24 25

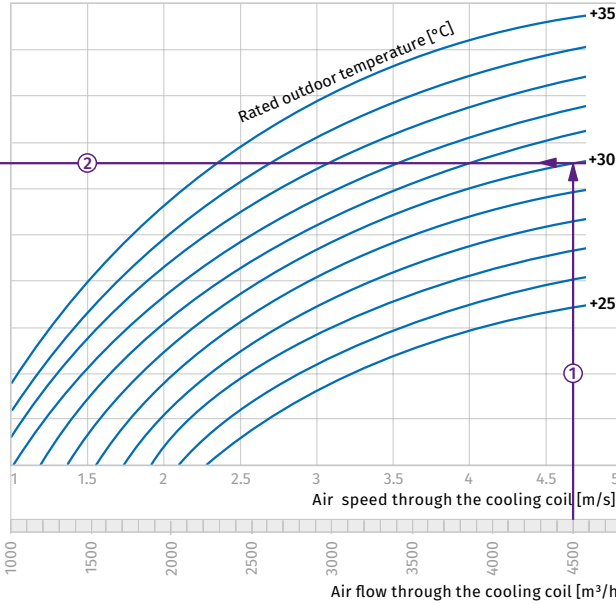

Coiling unit capacity [kW]

5 10 15 20 25 30 35

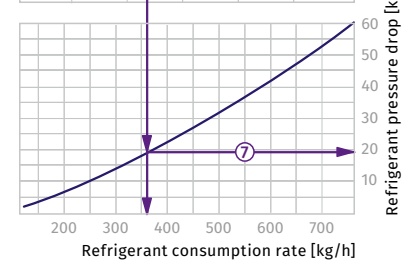
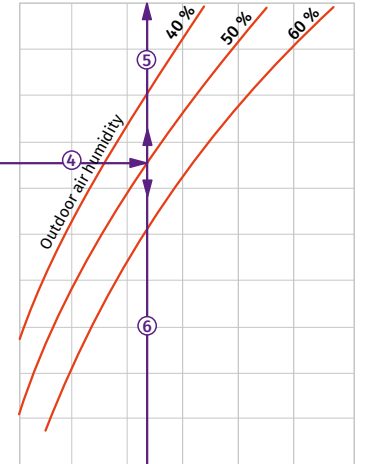

How to use water heater diagrams.

The air flow is 4000 m³/h and the air speed in the cooling unit is 4.15 m/s ①.

- To calculate the coldest air temperature find the intersection point of the air flow line ① with the rated outer summer temperature shown in blue line (e.g., +32 °C) and draw the line ② to the left until it crosses the outdoor air humidity curve (e.g. 50 %). From this point draw a vertical line to the supply air temperature downstream of the cooling unit (+19.8 °C) ③.

- To calculate the power of the cooling unit find the intersection point of the air flow ① with the rated summer temperature (e.g., +32 °C) and draw the line ④ to the right until it crosses the air humidity curve (e.g., 50 %). From this point draw a vertical line to the cooling unit power axis (28.5 kW).

- To define the necessary refrigerant flow through the cooling unit drop a perpendicular ⑥ on the axis which corresponds to refrigerant flow through the cooling unit (360kg/h).
- To define refrigerant pressure drop in the cooling unit find the intersection point of line ⑥ with the pressure drop chart and draw a perpendicular ⑦ to the right until it crosses the refrigerant pressure axis (19.0 kPa).

KFK 80x50-3

Air temperature after cooling unit [°C]

15 16 17 18 19 20 21 22 23 24 25

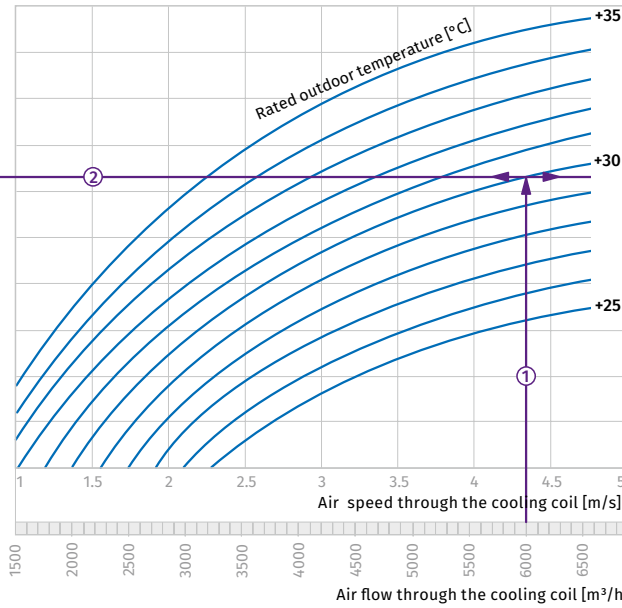
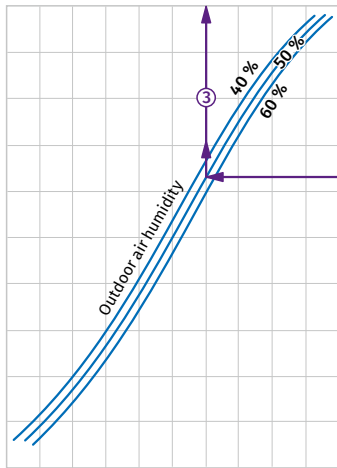

Coiling unit capacity [kW]

5 10 15 20 25 30 35 40 45

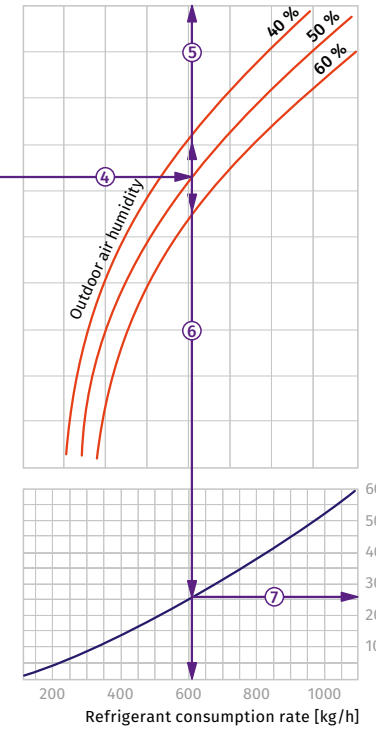

How to use water heater diagrams.

The air flow is 6000 m³/h and the air speed in the cooling unit is 4.35 m/s ①.

- To calculate the coldest air temperature find the intersection point of the air flow line ① with the rated outer summer temperature shown in blue line (e.g., +32 °C) and draw the line ② to the left until it crosses the outdoor air humidity curve (e.g. 50 %). From this point draw a vertical line to the supply air temperature downstream of the cooling unit (+19.9 °C) ③.

- To calculate the power of the cooling unit find the intersection point of the air flow ① with the rated summer temperature (e.g., +32 °C) and draw the line ④ to the right until it crosses the air humidity curve (e.g., 50 %). From this point draw a vertical line to the cooling unit power axis (43 kW) ⑤.

- To define the necessary refrigerant flow through the cooling unit drop a perpendicular ⑥ on the axis which corresponds to refrigerant flow through the cooling unit (605 kg/h).
- To define refrigerant pressure drop in the cooling unit find the intersection point of line ⑥ with the pressure drop chart and draw a perpendicular ⑦ to the right until it crosses the refrigerant pressure axis (26.0 kPa).

KFK 90x50-3

Air temperature after cooling unit [°C]

15 16 17 18 19 20 21 22 23 24 25

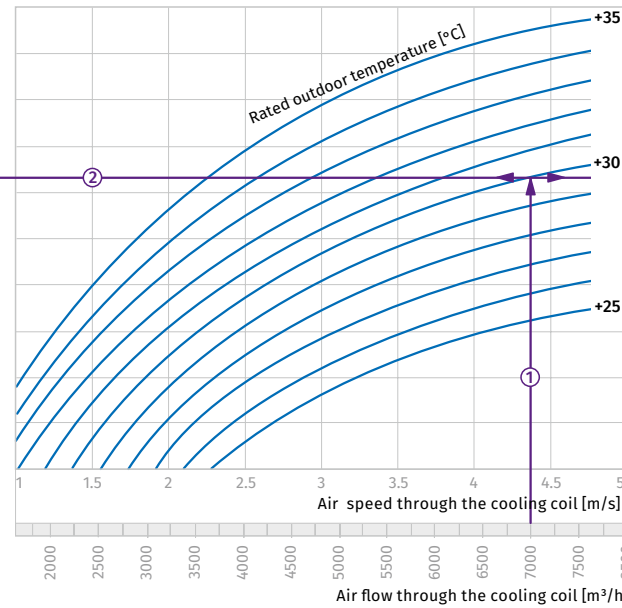
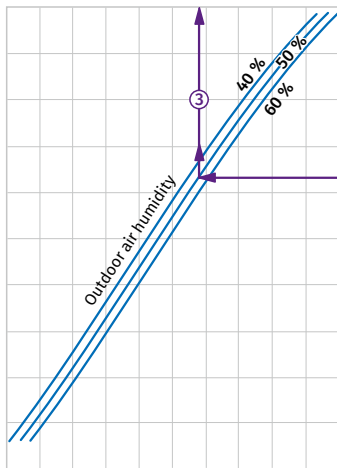

Coiling unit capacity [kW]

5 10 15 20 25 30 35 40 45 50 55

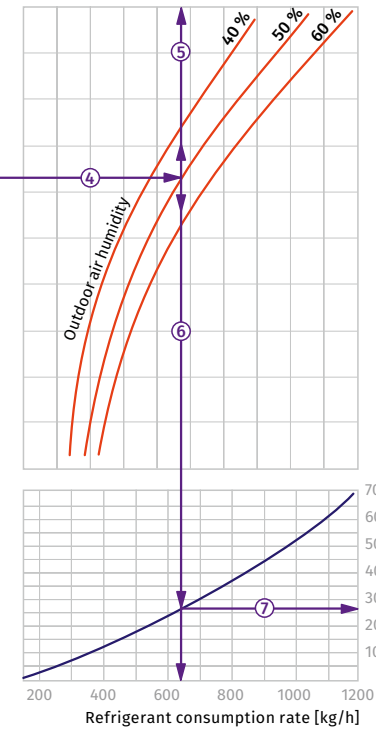

How to use water heater diagrams.

The air flow is 7000 m³/h and the air speed in the cooling unit is 4.4 m/s ①.

- To calculate the coldest air temperature find the intersection point of the air flow line ① with the rated outer summer temperature shown in blue line (e.g., +32 °C) and draw the line ② to the left until it crosses the outdoor air humidity curve (e.g. 50 %). From this point draw a vertical line to the supply air temperature downstream of the cooling unit (+19.7 °C) ③.

- To calculate the power of the cooling unit find the intersection point of the air flow ① with the rated summer temperature (e.g., +32 °C) and draw the line ④ to the right until it crosses the air humidity curve (e.g., 50 %). From this point draw a vertical line to the cooling unit power axis (47 kW) ⑤.

- To define the necessary refrigerant flow through the cooling unit drop a perpendicular ⑥ on the axis which corresponds to refrigerant flow through the cooling unit (640 kg/h).
- To define refrigerant pressure drop in the cooling unit find the intersection point of line ⑥ with the pressure drop chart and draw a perpendicular ⑦ to the right until it crosses the refrigerant pressure axis (26.0 kPa).

KFK 100x50-3

Air temperature after cooling unit [°C]

15 16 17 18 19 20 21 22 23 24 25

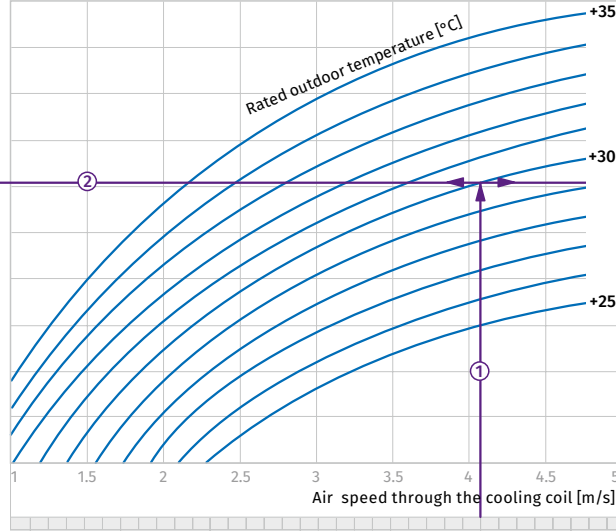
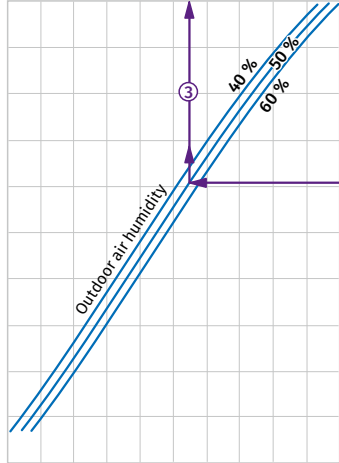

Air speed through the cooling coil [m/s]
Air flow through the cooling coil [m³/h]

Coiling unit capacity [kW]

5 10 15 20 25 30 35 40 45 50 55 60

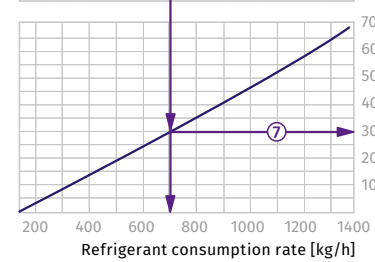
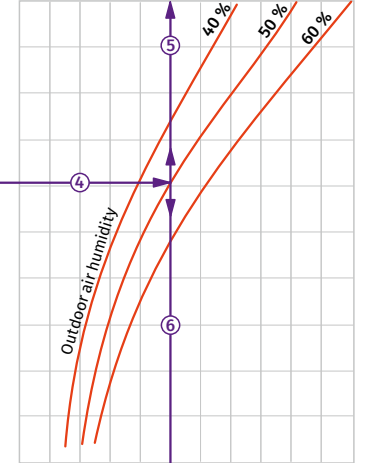

Refrigerant consumption rate [kg/h]
Refrigerant pressure drop [kPa]

How to use water heater diagrams.

The air flow is 7000 m³/h and the air speed in the cooling unit is 4.1 m/s ①.

- To calculate the coldest air temperature find the intersection point of the air flow line ① with the rated outer summer temperature shown in blue line (e.g., +32 °C) and draw the line ② to the left until it crosses the outdoor air humidity curve (e.g. 50 %). From this point draw a vertical line to the supply air temperature downstream of the cooling unit (+19.6 °C) ③.

- To calculate the power of the cooling unit find the intersection point of the air flow ① with the rated summer temperature (e.g., +32 °C) and draw the line ④ to the right until it crosses the air humidity curve (e.g., 50 %). From this point draw a vertical line to the cooling unit power axis (52 kW) ⑤.

- To define the necessary refrigerant flow through the cooling unit drop a perpendicular ⑥ on the axis which corresponds to refrigerant flow through the cooling unit (710 kg/h).
- To define refrigerant pressure drop in the cooling unit find the intersection point of line ⑥ with the pressure drop chart and draw a perpendicular ⑦ to the right until it crosses the refrigerant pressure axis (30.0 kPa).

SD

Silencers for round ducts

Features

- For attenuation of noise produced by a ventilation system and spreaded along ventilation ductworks.
- Used jointly with sound-insulated fans in premises with high requirements to noise level produced by ventilation equipment.
- Compatible with Ø 100 mm up to 315 mm round air ducts.



Design

- Galvanized steel case is filled with non-flammable sound-absorbing material with protecting covering against fiber blowing.
- Airtight connection with air ducts due to connecting flanges with rubber seals.
- A great variety of standard ranges with several length options.

Mounting

- Fixing to round ducts with clamps.
- Any mounting position.
- For better sound absorption install the silencers in Series.

Designation key

Series	Connected air duct diameter [cm]	Length
SD	100; 125; 150; 160; 200; 250; 315	600; 900; 1200

Overall dimensions [mm]

Model	D	D1	L	L1	Weight [kg]
SD 100/600	99	200	600	50	2.2
SD 100/900	99	200	900	50	3.2
SD 100/1200	99	200	1200	50	4.3
SD 125/600	124	225	600	50	2.7
SD 125/900	124	225	900	50	4.1
SD 125/1200	124	225	1200	50	5.4
SD 150/600	149	250	600	50	2.8
SD 150/900	149	250	900	50	4.2
SD 150/1200	149	250	1200	50	5.6
SD 160/600	159	260	600	50	3.1
SD 160/900	159	260	900	50	4.6
SD 160/1200	159	260	1200	50	6.2
SD 200/600	199	300	600	50	3.5
SD 200/900	199	300	900	50	5.3
SD 200/1200	199	300	1200	50	7.1
SD 250/600	249	350	600	50	4.2
SD 250/900	249	350	900	50	6.2
SD 250/1200	249	350	1200	50	8.3
SD 315/600	314	415	600	50	4.7
SD 315/900	314	415	900	50	7.1
SD 315/1200	314	415	1200	50	9.4

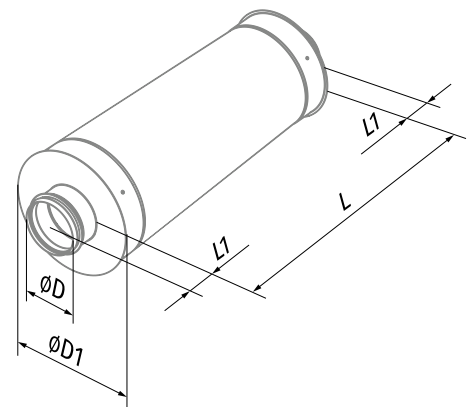

Noise level reduction, dB (octave-frequency band [Hz])

Model	63 Hz	125 Hz	250 Hz	500 Hz	1000 Hz	2000 Hz	4000 Hz	8000 Hz
SD 100/600	4	8	10	20	34	30	13	14
SD 100/900	5	10	15	23	44	30	16	15
SD 100/1200	6	11	19	28	50	34	20	18
SD 125/600	3	5	6	15	28	17	10	9
SD 125/900	4	9	12	22	43	22	16	12
SD 125/1200	4	9	16	27	48	27	21	17
SD 150/600	2	4	8	16	32	11	7	7
SD 150/900	3	5	9	18	36	25	13	14
SD 150/1200	4	8	14	25	43	30	18	19
SD 160/600	2	4	8	17	33	11	7	7
SD 160/900	2	5	10	19	37	25	13	15
SD 160/1200	4	10	14	24	42	30	19	20
SD 200/600	2	4	6	10	27	13	7	7
SD 200/900	3	7	11	20	39	23	8	7
SD 200/1200	4	10	14	23	40	26	13	12
SD 250/600	4	5	6	11	22	12	7	6
SD 250/900	4	5	7	16	32	20	12	10
SD 250/1200	4	6	8	17	34	22	14	12
SD 315/600	2	4	5	10	17	9	6	5
SD 315/900	3	5	8	17	30	14	10	8
SD 315/1200	4	7	11	22	36	18	14	10

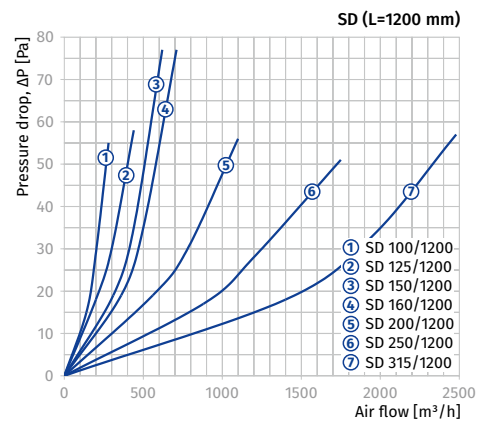
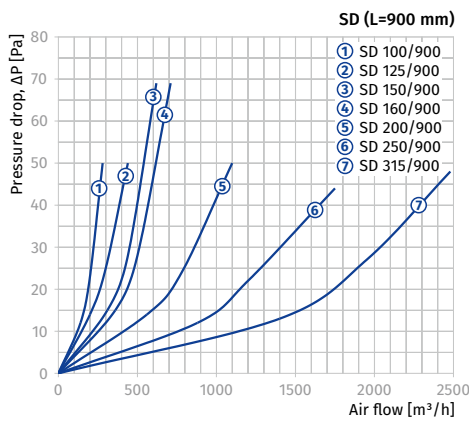
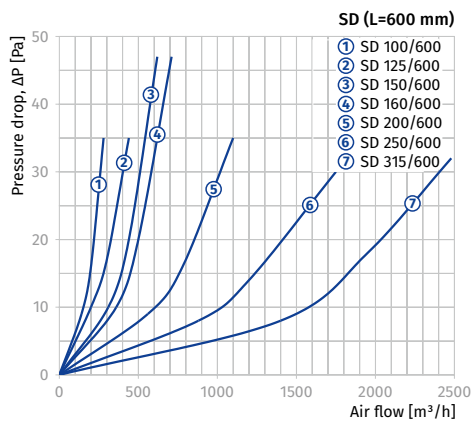

SDF

Flexible silencers for round ducts

Features

- For attenuation of noise produced by a ventilation system and spreaded along ventilation ductworks.
- Used jointly with sound-insulated fans in premises with high requirements to noise level produced by ventilation equipment.
- Compatible with Ø 100 mm up to 315 mm round air ducts.



Design

- Consists of outer and inner flexible spiral seam air ducts made of aluminium alloy and filled with non-flammable sound-absorbing material.
- Internal surface is perforated and covered with protection coating to prevent fiber blowing-out.
- A great variety of standard ranges with several length options.

Mounting

- Fixing to round ducts with clamps.
- Any mounting position.
- For better sound absorption install the silencers in Series.
- Fixing on both ends and in the middle to prevent sagging.

Designation key

Series	Connected air duct diameter [mm]	Length
SDF	100; 125; 150; 160; 200; 250; 315	600; 900; 1200

Overall dimensions [mm]

Model	D	D1	L	L1	Weight [kg]
SDF 100/600	99	220	600	55	1.6
SDF 100/900	99	220	900	55	2.4
SDF 100/2000	99	220	2000	55	5.2
SDF 125/600	124	270	600	55	2.0
SDF 125/900	124	270	900	55	3.0
SDF 125/2000	124	270	2000	55	6.6
SDF 150/600	149	270	600	55	2.1
SDF 150/900	149	270	900	55	3.1
SDF 150/2000	149	270	2000	55	6.8
SDF 160/600	159	270	600	55	2.1
SDF 160/900	159	270	900	55	3.2
SDF 160/2000	159	270	2000	55	7.0
SDF 200/600	199	320	600	55	2.6
SDF 200/900	199	320	900	55	3.9
SDF 200/2000	199	320	2000	55	8.6
SDF 250/600	249	370	600	55	3.0
SDF 250/900	249	370	900	55	4.5
SDF 250/2000	249	370	2000	55	10.1
SDF 315/600	314	420	600	55	3.4
SDF 315/900	314	420	900	55	5.1
SDF 315/2000	314	420	2000	55	11.4

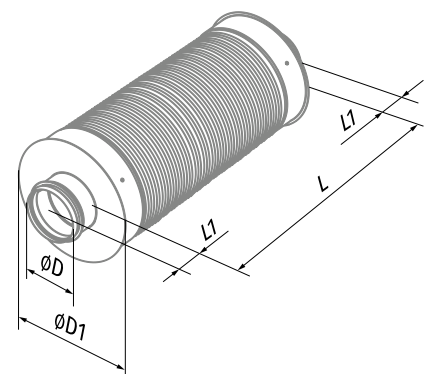

Noise level reduction, dB (octave-frequency band [Hz])

Model	63 Hz	125 Hz	250 Hz	500 Hz	1000 Hz	2000 Hz	4000 Hz	8000 Hz
SDF 100/600	6	8	13	22	28	34	17	20
SDF 100/900	8	10	15	25	33	40	21	23
SDF 100/2000	10	15	24	48	53	51	39	36
SDF 125/600	4	7	14	20	31	31	13	12
SDF 125/900	5	9	16	23	36	37	17	16
SDF 125/2000	7	15	23	47	55	50	28	25
SDF 150/600	3	7	12	32	40	40	19	20
SDF 150/900	4	8	14	40	48	49	26	25
SDF 150/2000	5	10	21	42	50	48	26	25
SDF 160/600	3	7	12	20	25	24	10	12
SDF 160/900	3	8	13	21	28	28	13	16
SDF 160/2000	5	11	20	40	48	48	25	25
SDF 200/600	2	5	12	20	26	21	10	10
SDF 200/900	3	6	12	22	28	24	12	13
SDF 200/2000	4	11	22	42	51	34	19	23
SDF 250/600	2	3	8	16	22	13	10	10
SDF 250/900	2	4	9	18	25	16	11	12
SDF 250/2000	3	6	16	30	39	27	17	22
SDF 315/600	2	4	9	18	21	12	7	9
SDF 315/900	2	5	11	21	24	14	8	10
SDF 315/2000	4	7	17	34	39	24	14	18

SILENCERS

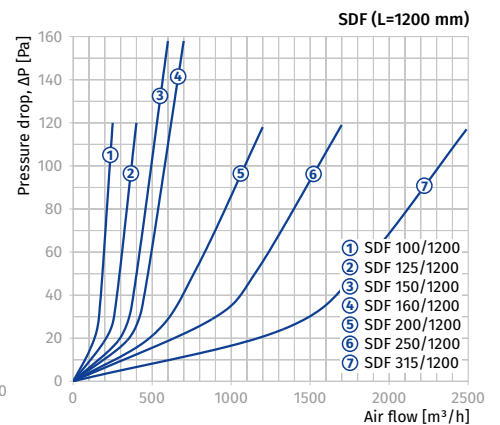
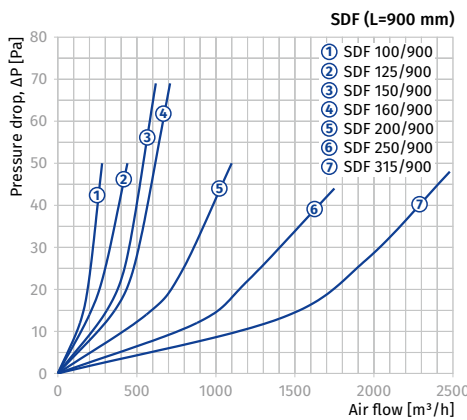
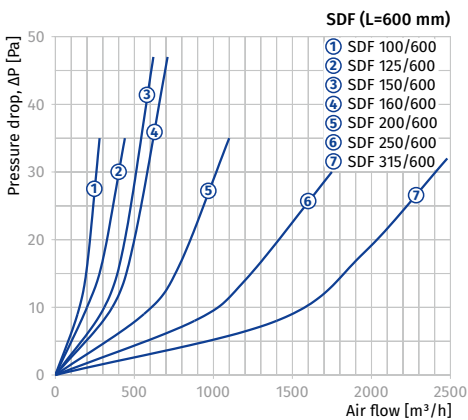

SD

Silencers for rectangular ducts

Features

- For attenuation of the noise produced by a ventilation system and spreaded along ventilation ductworks.
- Used jointly with sound-insulated fans in premises with high requirements to noise level produced by ventilation equipment.
- Compatible with 400x200 mm up to 1000x500 mm rectangular air ducts.



Design

- Galvanized steel case and sleeves.
- The plates are filled with non-flammable sound-absorption material with protecting coating to prevent fiber blowing.

Mounting

- Fixing to rectangular ducts with flange connection.
- For maximum sound absorption capacity provide a straight air duct section at least 1 m long towards the silencer.
- For better sound absorption install the silencers in Series

Designation key

Series	Flange size (WxH) [mm]
SD	40x20; 50x25; 50x30; 60x30; 60x35; 70x40; 80x50; 90x50; 100x50

Overall dimensions [mm]

Model	B	B1	B2	H	H1	H2	L	Weight [kg]
SD 40x20	400	420	440	200	220	240	950	18.5
SD 50x25	500	520	540	250	270	290	950	20.5
SD 50x30	500	520	540	300	320	340	950	24.5
SD 60x30	600	620	640	300	320	340	950	26.5
SD 60x35	600	620	640	350	370	390	950	28.7
SD 70x40	700	720	740	400	420	440	1010	36.7
SD 80x50	800	820	840	500	520	540	1010	50.0
SD 90x50	900	920	940	500	520	540	1010	51.7
SD 100x50	1000	1020	1040	500	520	540	1010	57.3

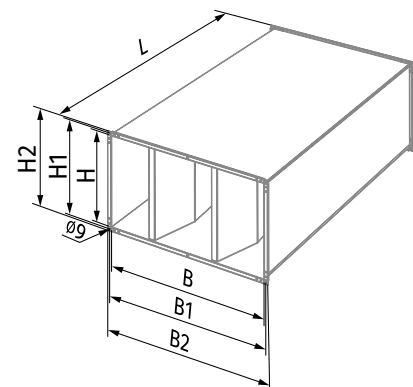

Noise level reduction, dB (octave-frequency band [Hz])

Model	63 Hz	125 Hz	250 Hz	500 Hz	1000 Hz	2000 Hz	4000 Hz	8000 Hz
SD 40x20	3	7	10	23	27	30	25	22
SD 50x25	3	6	11	22	26	25	27	22
SD 50x30	3	6	10	23	24	25	23	18
SD 60x30	3	6	10	21	24	30	24	17
SD 60x35	3	5	11	22	25	29	24	21
SD 70x40	4	7	10	15	22	19	21	18
SD 80x50	5	6	11	17	21	20	22	20
SD 90x50	3	6	10	16	20	20	21	15
SD 100x50	4	6	11	16	21	21	23	17

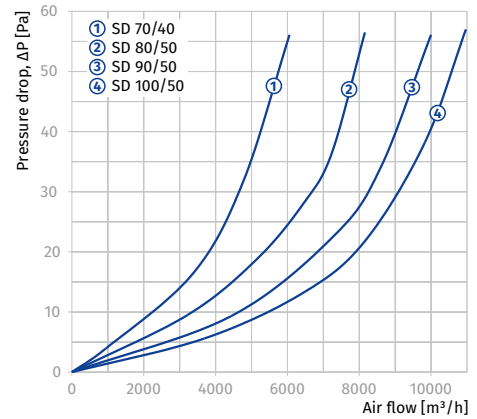
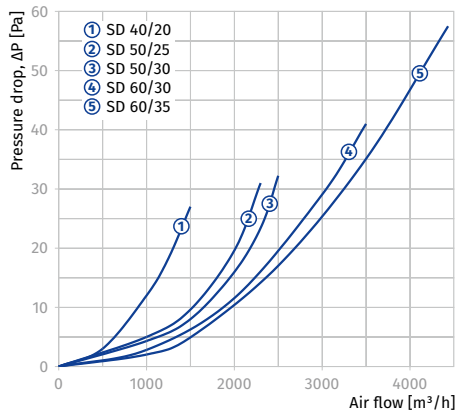

VK

Air dampers for round ducts

Features

- For manual regulation of air flow volume in the air ducts.
- Compatible with Ø 80 to 450 mm round air ducts.



Design

- The casing and the rotary blade are made of galvanized steel.
- Airtight connection to air ducts due to rubber seals.
- Air flow manual regulation with a metal handle equipped with a lever and a locking device for fixing the position of the rotary blades.

Mounting

- Fixing to round ducts with clamps.

Designation key

Series	Connected air duct diameter [mm]
VK	80; 100; 125; 150; 160; 200; 250; 315; 355; 400; 450

Overall dimensions [mm]

Model	Ø D	B	L	Weight [kg]
VK 80	79	140	200	0.57
VK 100	99	170	200	0.68
VK 125	124	195	200	0.82
VK 150	149	220	200	0.95
VK 160	159	230	200	1.01
VK 200	199	270	200	1.29
VK 250	249	320	200	1.64
VK 315	314	385	240	2.51
VK 355	348	425	240	2.84
VK 400	399	470	240	3.38
VK 450	449	520	240	3.94

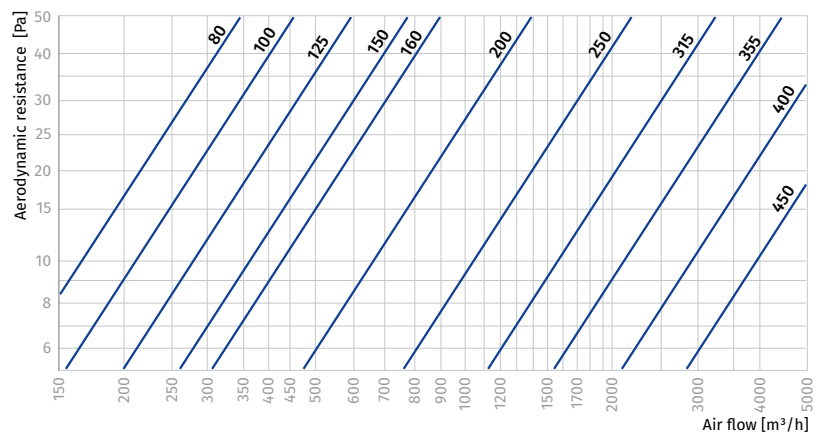
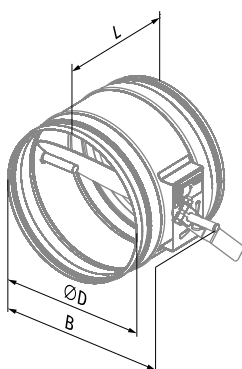

VKA

Air dampers for round ducts

Features

- For automatic shutoff of air ducts installed in ventilation systems of various premises.
- Compatible with Ø 80 to 450 mm round air ducts.



Design

- The casing and the rotary blade are made of galvanized steel.
- Airtight connection to air ducts due to rubber seals.
- A shaft and a mounting pad are provided for BELIMO electric actuator. Compatible actuators are shown in the table below.

Designation key

Series	Connected air duct diameter [mm]
VKA	80; 100; 125; 150; 160; 200; 250; 315; 355; 400; 450

Overall dimensions [mm]

Model	Ø D	B	L	H	Weight [kg]
VKA 80	79	190	200	170	0.6
VKA 100	99	220	200	180	0.72
VKA 125	124	245	200	195	0.86
VKA 150	149	270	200	205	1.01
VKA 160	159	280	200	210	1.07
VKA 200	199	320	200	230	1.33
VKA 250	249	370	200	255	1.68
VKA 315	314	435	240	-	2.44
VKA 355	348	475	240	-	2.75
VKA 400	399	520	240	-	3.26
VKA 450	449	570	240	-	3.78

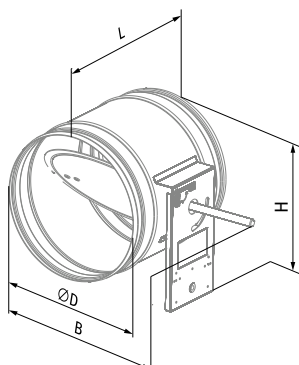

Mounting

- Fixing to round ducts with clamps.
- While mounting provide enough space for accessing the electric actuator.

Compatibility table

Compatibility table for shutters with an electrical actuator

Model	Actuator type			
	Electric actuator, 230 V	Electric actuator with spring return, 230 V	Electric actuator, 24 V	Electric actuator with spring return, 24 V
VKA 80	CM230 / LM230A	TF230	CM24 / LM24A	TF24
VKA 100	CM230 / LM230A	TF230	CM24 / LM24A	TF24
VKA 125	CM230 / LM230A	TF230	CM24 / LM24A	TF24
VKA 150	CM230 / LM230A	TF230	CM24 / LM24A	TF24
VKA 160	CM230 / LM230A	TF230	CM24 / LM24A	TF24
VKA 200	CM230 / LM230A	TF230	CM24 / LM24A	TF24
VKA 250	CM230 / LM230A	TF230	CM24 / LM24A	TF24
VKA 315	CM230 / LM230A	TF230	CM24 / LM24A	TF24
VKA 355	CM230 / LM230A	TF230	CM24 / LM24A	TF24
VKA 400	CM230 / LM230A	TF230	CM24 / LM24A	TF24
VKA 400	CM230 / LM230A	TF230	CM24 / LM24A	TF24

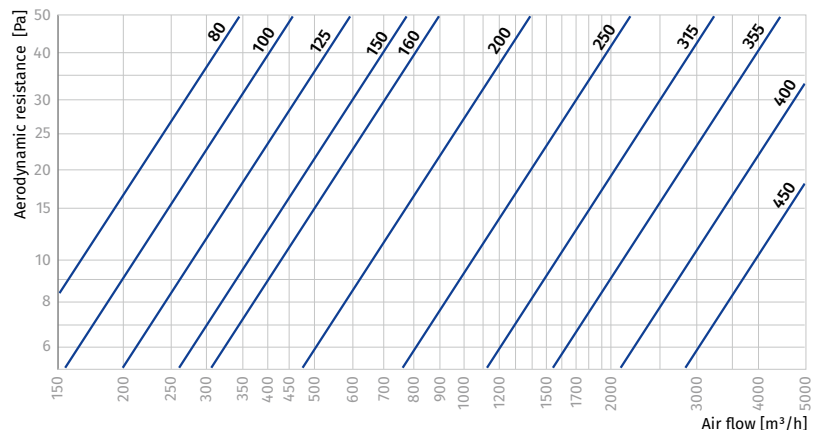

VRV

Backdraft dampers with spring for round ducts

Features

- For automatic shutoff of the air ducts and prevention of back drafting when the fan is off. Suitable for installation in various premises.
- Compatible with Ø 100 up to 315 mm round air ducts.



Design

- Galvanized steel case.
- Two spring-loaded blades made of aluminium.
- Blades are opened by air pressure and are closed with a spring.

Mounting

- Fixing to round ducts with clamps.
- Provide vertical position of blade axis.
- Install the backdraft damper into the ventilation system with respect to the air flow direction.

Designation key

Series	Connected air duct diameter [mm]
VRV	100; 125; 150; 160; 200; 250; 315

Overall dimensions [mm]

Model	D	L	Weight [kg]
VRV 100	99	80	0.18
VRV 125	124	100	0.27
VRV 150	149	115	0.38
VRV 160	159	120	0.42
VRV 200	199	145	0.63
VRV 250	249	165	0.90
VRV 315	314	190	1.31

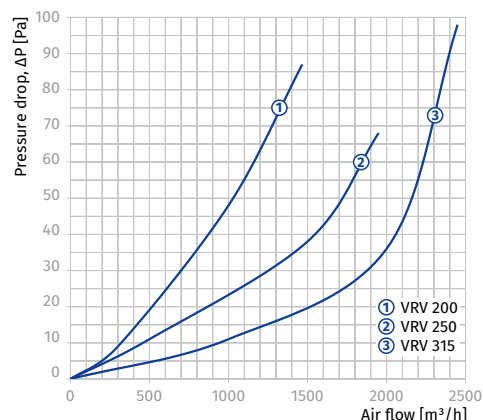
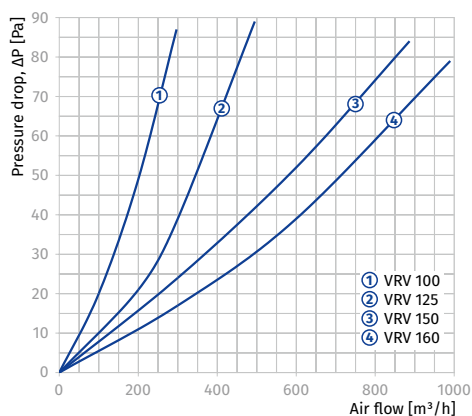
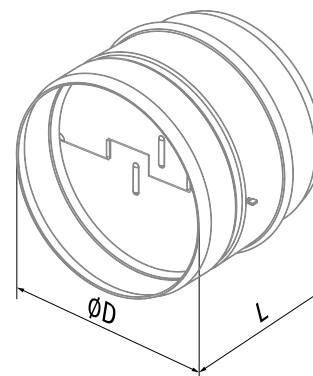

VRVS

Backdraft air dampers for round ducts



Features

- o For automatic shut-off of the air ducts and prevention of back drafting when the fan off. Suitable for installation in various premises.
- o Compatible with Ø 100 up to 315 mm round air ducts.

Design

- o Galvanized steel case and rotary gravity-actuated blade.
- o Airtight connection with the air ducts due to rubber seals.
- o The damper blade is opened with air pressure and reset automatically when the fan is off and no air pressure is produced.
- o Manual handle with a counterweight to regulate the damper opening-closing sensitivity.

Mounting

- o Fixing to round ducts with clamps.
- o Provide free gravity actuated movement of the blade.
- o Install the backdraft damper into the ventilation system with respect to the air flow direction.

Designation key

Series	Connected air duct diameter [mm]
VRVS	100; 125; 150; 160; 200; 250; 315

Overall dimensions [mm]

Model	D	B	L	Weight [kg]
VRVS 100	99	139	150	0.65
VRVS 125	124	162	170	0.81
VRVS 150	149	194	180	0.97
VRVS 160	159	204	190	1.06
VRVS 200	199	238	220	1.57
VRVS 250	249	290	270	2.2
VRVS 315	314	356	340	3.24

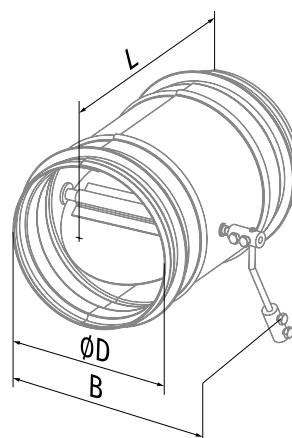

VK

Air dampers for rectangular ducts

Features

- For manual regulation of air flow or shut-off of air ducts.
- Compatible with 400x200 up to 600x350 mm rectangular air ducts.



Design

- Galvanized steel case and rotary blade.
- Manual regulation with a metal handle equipped with a lever and a locking device for fixing the position of the rotary blade.

Mounting

- Fixing to rectangular ducts with flange connection.
- Mounting with galvanized bolts and clamps that fix the end flanges of the air shutter to the mating flanges of the air ducts or any other ventilation system components.

Designation key

Series	Flange size [cm]
VK	40x20; 50x25; 50x30; 60x30; 60x35

Overall dimensions [mm]

Model	B	B1	B2	H	H1	L	Weight [kg]
VK 40x20	400	440	460	200	240	202	3.0
VK 50x25	500	540	560	250	290	202	3.8
VK 50x30	500	540	560	300	340	202	3.1
VK 60x30	600	640	660	300	340	202	4.2
VK 60x35	600	640	660	350	390	202	5.1

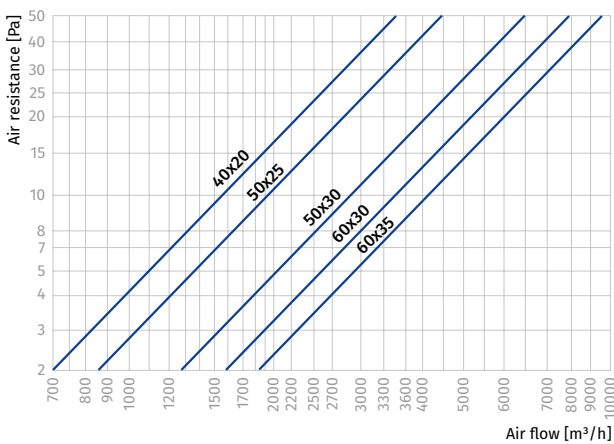
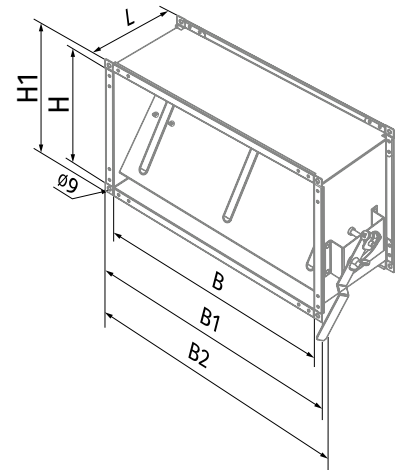

AVK

Air dampers for rectangular ducts

Features

- For automatic regulation of air flow volume or shut-off of air ducts installed in various premises.
- Compatible with 400x200 up to 600x350 mm rectangular air ducts.

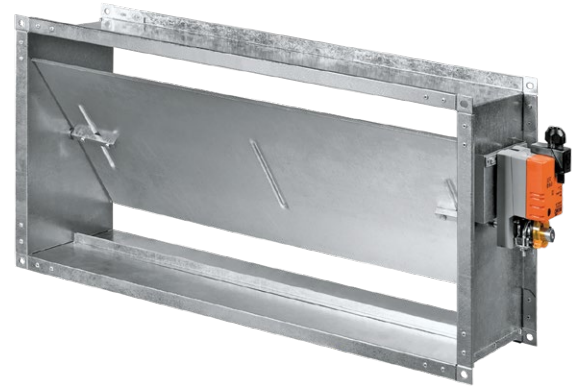

Design

- Galvanized steel case and rotary blade.
- Automatic control of the regulating mechanism with a servo actuator installed on the damper shaft. Three-point circuit provides regulation of the rotary blade; adjustable with mechanical stop blocks, maximum angle 95°. The servo actuator has overheating protection.
- Switching to manual control mode if required.

Mounting

- Fixing to rectangular ducts with flange connection.
- Mounting with galvanized bolts and clamps that fix the end flanges of the air shutter to the mating flanges of the air ducts or any other ventilation system components.
- While mounting provide enough space for accessing the servo actuator.

Designation key

Series	Flange size [cm]
AVK	40x20; 50x25; 50x30; 60x30; 60x35

Overall dimensions [mm]

Model	B	B1	B2	H	H1	L	Weight [kg]
AVK 40x20	400	440	503	200	240	202	3.6
AVK 50x25	500	540	603	250	290	202	4.4
AVK 50x30	500	540	603	300	340	202	4.8
AVK 60x30	600	640	703	300	340	202	5.4
AVK 60x35	600	640	703	350	390	202	5.8

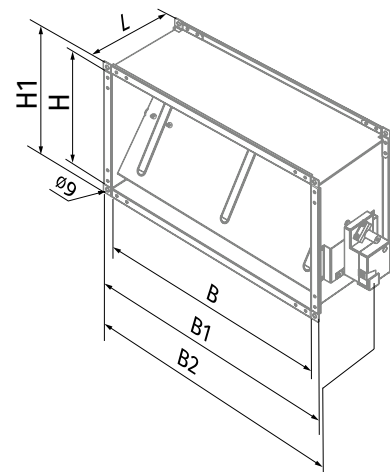
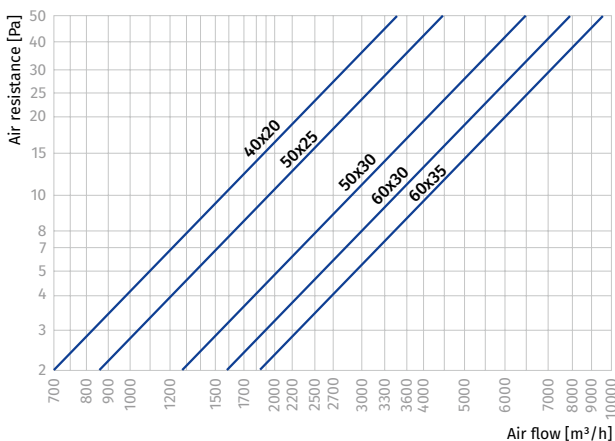

SL

Air dampers for rectangular ducts

Features

- For manual regulation of air flow volume or shut-off of air ducts installed in ventilation systems of various premises.
- Compatible with 400x200 mm up to 1000x500 mm rectangular air ducts.



Design

- The multi-blade design with the counter-rotated blades.
- The casing is made of galvanized steel.
- The rotary blades from aluminium profile are rotated with the gears.
- Air flow manual regulation with a metal handle equipped with a lever and a locking device to fix position of the rotary blades.
- A shaft and a mounting pad are provided for BELIMO electric actuator. Compatible actuators are shown in the table below.

Mounting

- Fixing to rectangular ducts with flange connection.
- Mounting with galvanized bolts and clamps that fix the end flanges of the air flow regulators to the mating flanges of the air ducts or any other ventilation system components.

Designation key

Series	Flange size [cm]
SL	40x20; 50x25; 50x30; 60x30; 60x35; 70x40; 80x50; 90x50; 100x50

Overall dimensions [mm]

Model	B	B1	B2	H	H1	L	Weight [kg]
SL 40x20	400	440	540	200	240	170	3.5
SL 50x25	500	540	640	250	290	170	4.2
SL 50x30	500	540	640	300	340	170	4.9
SL 60x30	600	640	740	300	340	170	5.4
SL 60x35	600	640	740	350	390	170	5.7
SL 70x40	700	740	840	400	440	170	7.7
SL 80x50	800	840	940	500	540	170	8.8
SL 90x50	900	940	1040	500	540	170	9.6
SL 100x50	1000	1040	1140	500	540	170	10.3

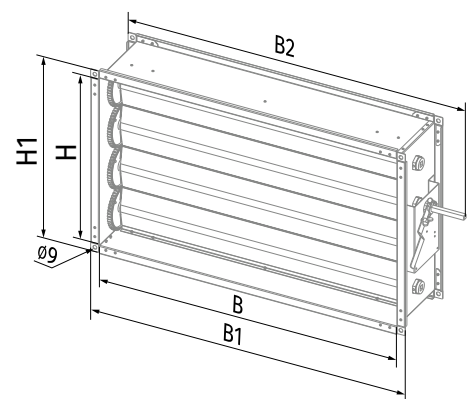

Compatibility table of air dampers with electric actuators

	Actuator type			
	Electric actuator, 230 V	Electric actuator with spring return, 230 V	Electric actuator, 24 V	Electric actuator with spring return, 24 V
SL 40x20	CM230 / LM230A	TF230 / LF230	CM24 / LM24A	TF24 / LF24
SL 50x25	CM230 / LM230A	TF230 / LF230	CM24 / LM24A	TF24 / LF24
SL 50x30	CM230 / LM230A	TF230 / LF230	CM24 / LM24A	TF24 / LF24
SL 60x30	CM230 / LM230A	TF230 / LF230	CM24 / LM24A	TF24 / LF24
SL 60x35	CM230 / LM230A	TF230 / LF230	CM24 / LM24A	TF24 / LF24
SL 70x40	LM230A	LF230	LM24A	LF24
SL 80x50	LM230A	LF230	LM24A	LF24
SL 90x50	LM230A	LF230	LM24A	LF24
SL 100x50	LM230A	LF230	LM24A	LF24

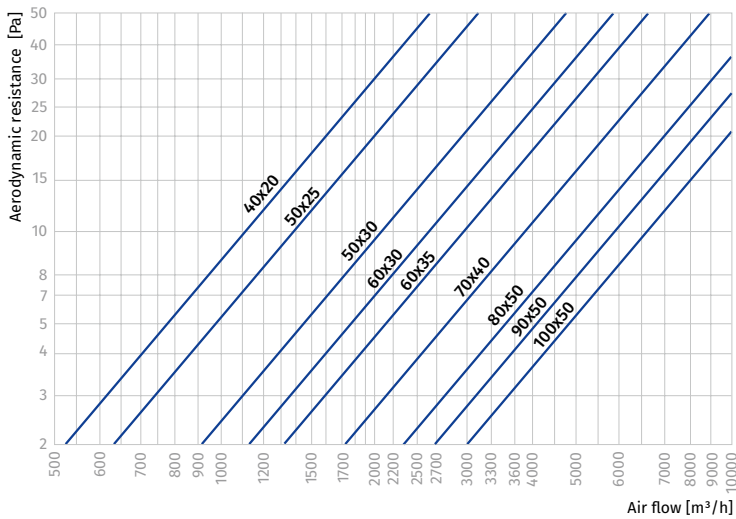

VRVS

Backdraft air dampers for rectangular ducts

Features

- For automatic shut-off of the air ducts and prevention of back drafting when the fan is off. Suitable for installation in various premises.
- Compatible with 400x200 up to 600x350 mm rectangular air ducts.

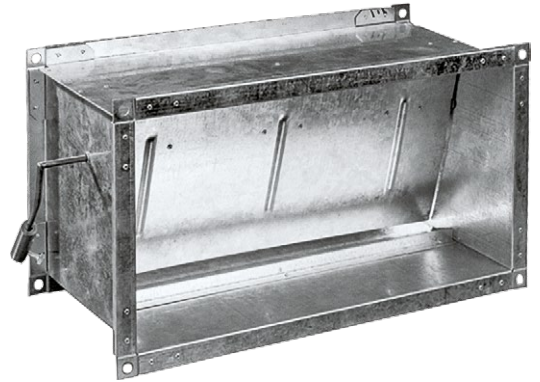

Design

- Galvanized steel case and rotary gravity-actuated blade.
- The damper blade is opened with air pressure and reset automatically when the fan is off and no air pressure is produced.
- Manual handle with a counterweight to regulate the damper opening-closing sensitivity.

Mounting

- Fixing to rectangular ducts in upright position.
- Provide free gravity actuated movement of the blade.
- Install the backdraft damper into the ventilation system with respect to the air flow direction.

Designation key

Series	Flange size [cm]
VRVS	40x20; 50x25; 50x30; 60x30; 60x35

Overall dimensions [mm]

Model	B	B1	B2	H	H1	L	Weight [kg]
VRVS 40x20	400	440	461	200	240	202	2.9
VRVS 50x25	500	540	561	200	290	202	3.73
VRVS 50x30	500	540	561	300	340	202	4.1
VRVS 60x30	600	640	661	300	340	202	4.64
VRVS 60x35	600	640	661	350	390	202	5.03

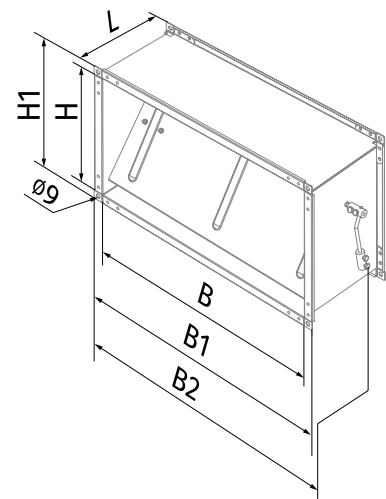

EVA

Flexible anti-vibration connectors for round ducts

Features

- For damping vibration generated by fans or ventilation equipment and transferred to air ducts.
- For partial compensation of ductwork distortion resulting from temperature changes.
- Compatible with \varnothing 100 up to 500 mm round air ducts.



Design

- Two galvanized steel flanges.
- Connecting vibration-isolating material is made of nylon reinforced polyethylene fabric.
- Not designed for mechanical load and cannot be used as a load-carrying structure.

Mounting

- Flexible vibration damping connectors are fixed to air ducts with clamps.

Designation key

Series	Connected air duct diameter [mm]
EVA	100; 125; 150; 160; 200; 250; 315; 355; 400; 450; 500

Overall dimensions [mm]

Model	D	L	Weight [kg]
EVA 100	101	130	0.14
EVA 125	126	130	0.17
EVA 150	151	130	0.21
EVA 160	161	130	0.22
EVA 200	201	130	0.28
EVA 250	251	130	0.35
EVA 315	316	130	0.44
EVA 355	356	130	0.50
EVA 400	401	130	0.56
EVA 450	451	130	0.64
EVA 500	501	130	0.71

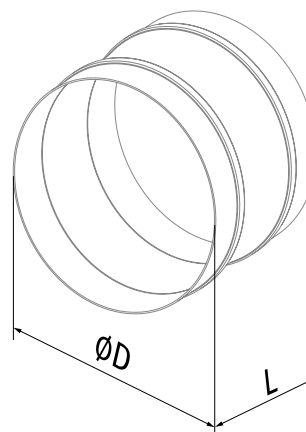

EVAF

Flexible anti-vibration connectors for round ducts

Features

- For damping the vibration generated by fans or ventilation equipment and transferred to air ducts in ventilation systems of various premises.
- For partial compensation of ductworks temperature deformation.
- Compatible with \varnothing 200 up to 630 mm round air ducts with flanges.



Design

- Two flanges are made of galvanized steel.
- The connecting vibration-isolating material is made of nylon reinforced polyethylene fabric.
- Not designed for mechanical load and cannot be used as a load carrying structure.

Mounting

- Flexible vibration damping connectors are fixed to air ducts with flange connection.

Designation key

Series	Connected air duct diameter [mm]
EVAF	200; 250; 300; 350; 400; 450; 500; 550; 630

Overall dimensions [mm]

Model	D	D1	L	Weight [kg]
EVAF 200	205	255	160	1.29
EVAF 250	260	306	160	1.21
EVAF 300	310	382	160	1.90
EVAF 350	362	421	160	2.06
EVAF 400	412	465	160	2.57
EVAF 450	462	515	160	2.88
EVAF 500	515	570	160	3.81
EVAF 550	565	636	160	4.53
EVAF 630	645	715	160	5.13

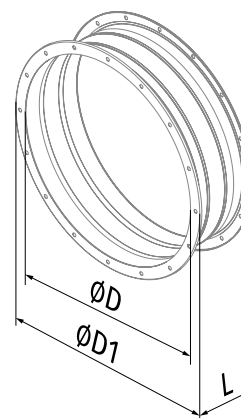

EVA

Flexible anti-vibration connectors for rectangular ducts



Features

- For damping of vibration generated by fans or ventilation equipment and transferred to air ducts for ventilation systems installed in various premises.
- For partial temperature distortion compensation in the ductworks.
- Compatible with rectangular 400x200 up to 1000x500 mm air ducts.

Design

- Two galvanized steel flanges.
- Connecting vibration-isolating material is made of nylon reinforced polyethylene fabric.
- Not designed for mechanical load and cannot be used as a load-carrying structure.

Mounting

- Mounting with galvanized bolts and clamps that fix the end flanges of the connector to the mating flanges of the air ducts or any other ventilation system components.

Designation key

Series	Flange size (WxH) [cm]
EVA	40x20; 50x25; 50x30; 60x30; 60x35; 70x40; 80x50; 90x50; 100x50

Overall dimensions [mm]

Model	B	B1	H	H1	Weight [kg]
EVA 40x20	400	440	200	240	1.1
EVA 50x25	500	540	250	290	1.4
EVA 50x30	500	540	300	340	1.6
EVA 60x30	600	640	300	340	1.82
EVA 60x35	600	640	350	390	1.95
EVA 70x40	700	740	400	440	2.4
EVA 80x50	800	840	500	540	2.8
EVA 90x50	900	940	500	540	3.0
EVA 100x50	1000	1040	500	540	3.2

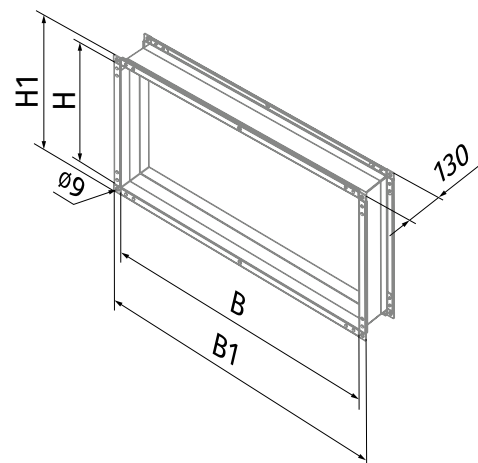

KZ

Clamps for round ducts

Features

- For reliable fixing of ventilation system components.
- Compatible with 100 up to 315 mm round ventilation system components.



Design

- Made of galvanized steel band.
- Sealed with microporous rubber from inside for vibration absorption.

Mounting

- Fixed on round ventilation system components.
- Round ventilation system components are fixed by a clamp with two bolts.

Designation key

Series	Connected air duct diameter [mm]
KZ	100; 125; 150; 160; 200; 250; 315

Overall dimensions [mm]

Model	D	H	Weight [kg]
KZ 100	100	172	0.206
KZ 125	125	198	0.232
KZ 150	150	224	0.296
KZ 160	160	232	0.358
KZ 200	200	274	0.42
KZ 250	250	326	0.55
KZ 315	315	380	0.65

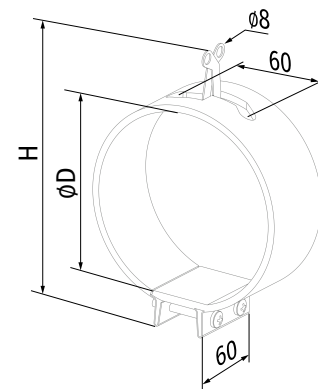

KZH

Clamps for round ducts

Features

- For reliable fixing of ventilation system components installed in various premises.
- Compatible with 100 up to 315 mm round ventilation system components.



Design

- Made of galvanized steel band.
- Sealed with microporous rubber from inside for vibration absorption.
- Equipped with a mounting bracket for fixing on wall or ceiling.

Mounting

- Fixed on round ventilation system components.
- Round ventilation system components are fixed by a clamp with a bolt.
- For installation on wall or ceiling use a mounting bracket fixed with dowels.

Designation key

Series	Connected air duct diameter [mm]
KZH	100; 125; 150; 160; 200; 250; 315

Overall dimensions [mm]

Model	D	L	Weight [kg]
KZH 100	100	204	0.21
KZH 125	125	229	0.22
KZH 150	150	254	0.25
KZH 160	160	264	0.26
KZH 200	200	304	0.31
KZH 250	250	354	0.35
KZH 315	315	419	0.42

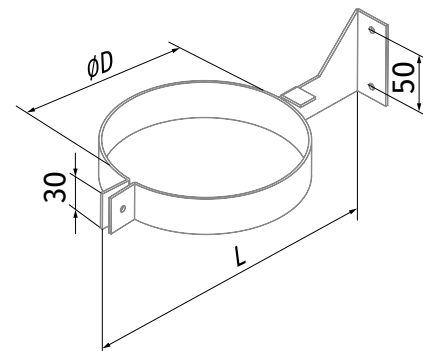

SGR-3/1

Sensor speed switch

Features

- On/off switch and speed selection for multi-speed fans.



Design

- Casing made of high-quality plastic.
- Glass sensor operating panel with three touch buttons for speed selection with light indication.
- Wall flush mounting.
- IP30 ingress protection rating.

Control

- Required speed is activated by touching the respectively marked speed button.
- The fan is turned off by touching the current speed button.

Mounting

- Designed for wall mounting in a flush mounting box.

Technical data

Parameters	SGR-3/1
Voltage 50 (60) Hz [V]	110–240
Max. current load [A]	1
Number of speeds	3
Cable cross section [mm ²]	from 0.35 up to 1
Temperature range [°C]	from -10 up to +45
Operating humidity range [%]	from 5 up to 80 (no condensation)
Service life	100 000 operations
Ingress Protection	IP30
Weight [g]	138

SPEED CONTROLLERS

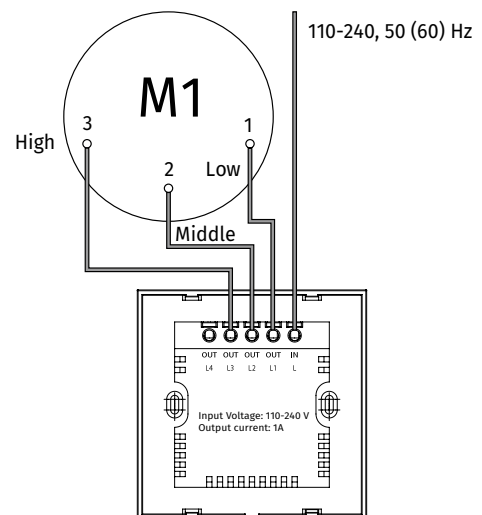
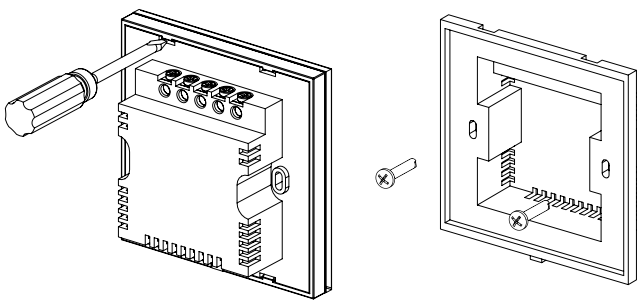

Overall dimensions [mm]

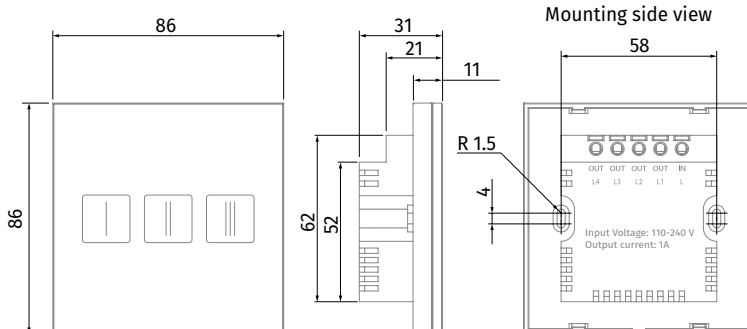

SGS E1 / SGS E2.5

Sensor speed controller



Features

- On/off switch and speed control for single-phase voltage controlled fans.

Design

- Casing made of high-quality plastic.
- Glass sensor panel with an ON/OFF button and two speed control buttons.
- The adjustable speed is displayed with the LED indicator.
- Wall flush mounting.
- IP30 ingress protection rating.

Mounting

- Designed for wall mounting in a flush mounting box.

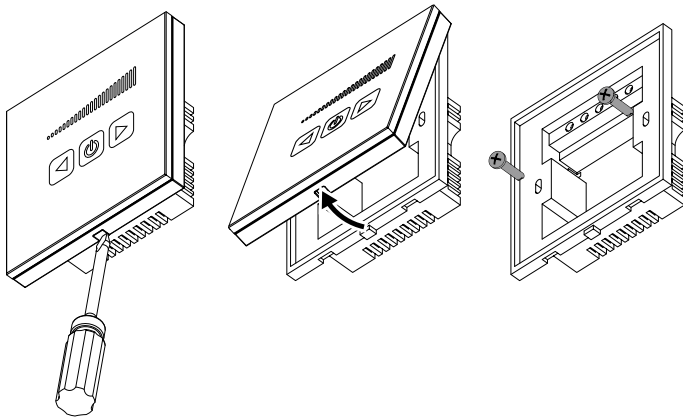

Technical data

Parameters	SGS E1	SGS E2.5
Voltage 50 (60) Hz [V]	230	230
Max. current load [A]	1	2.5
Cable cross section [mm ²]	from 0.35 up to 1	from 0.35 up to 1
Temperature range [°C]	from -10 up to +45	from -10 up to +45
Operating humidity range [%]	from 5 up to 80 (no condensation)	from 5 up to 80 (no condensation)
Service life	100 000 operations	100 000 operations
Ingress Protection	IP30	IP30
Weight [g]	138	138

SPEED CONTROLLERS

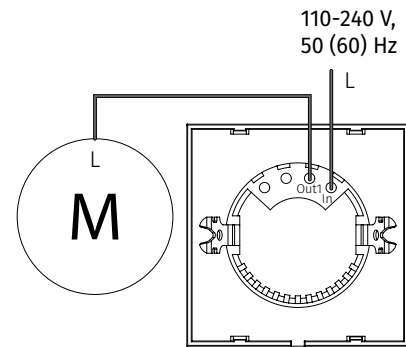

M – ventilation equipment motor

Overall dimensions [mm]

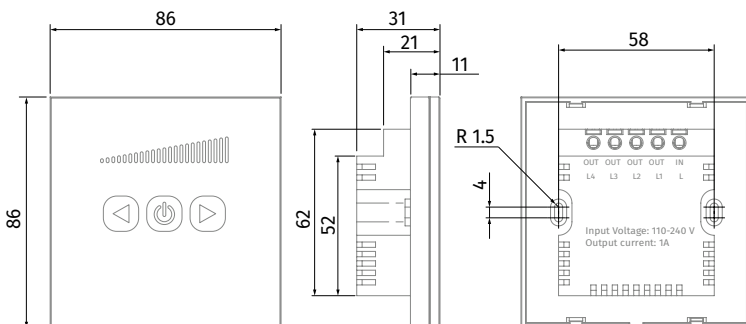

CDP-2/5 (3/5)

Multi-speed switch

Features

- On/off switch and speed switch for multi-speed fans.



Design

- Casing made of high-quality plastic.
- Flush wall mounting.
- IP40 ingress protection rating.

Control

- Switching of fan speed according to diagram 1 and switching of fan speed in parallel with switching the light in the room, diagram 2.

Mounting

- Indoor wall flush mounting in a mounting box.
- Suitable for installation in standard electric junction boxes.

Technical data

Parameters	CDP-2/5	CDP-3/5
Voltage 50 Hz [V]	1 ~ 230	1 ~ 230
Rated current [A]	3.0	3.0
Number of speeds	2	3
Overall dimensions AxBxC [mm]	88x88x51	88x88x51
Maximum ambient temperature [°C]	+40	+40
Ingress Protection	IP40	IP40

Wiring diagram options

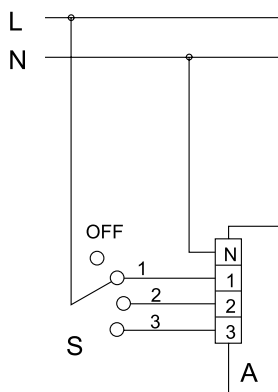

Diagram 1. The external switch S (CDP-3/5) switches the fan to one of three speeds and switches it off.

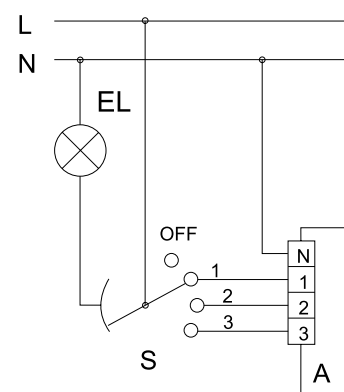

Diagram 2. The external switch S (CDP-3/5) switches the fan to one of three speeds and switches it off with parallel switching on/off the light in the room.

CDT E1.8

Thyristor speed controller



Features

- For switching fans on/off and for speed control of single-phase frequency controlled motors. For ventilation systems in various premises.

Design

- The casing is made of high-quality plastic.
- Mounting junction box for wall flush mounting.
- IP40 ingress protection rating.

Control

- Switching on/off by the control knob.
- Smooth speed control from minimum to maximum value. Minimum speed is set by a variable resistor on the control panel.
- Several fans can be controlled from one unit provided that the total current consumption does not exceed the permissible controller current.
- High efficiency and control accuracy.

Protection

- Input circuit protected with a thermal fuse.
- Equipped with a transient filter.

Mounting

- Indoor wall flush mounting in a mounting box.
- Suitable for installation in standard electric junction boxes.

Options

- Mounting box EDR-E for wall surface mounting available upon separate order.

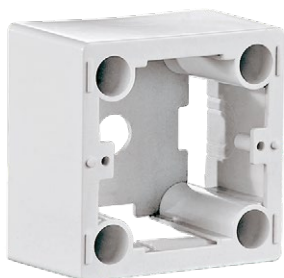

Technical data

Parameters	CDT E1.8
Voltage 50 Hz [V]	1 ~ 230
Rated current [A]	1.8
Overall dimensions AxBxC [mm]	80x80x63
Maximum ambient temperature [°C]	+35
Ingress Protection	IP40
Weight [g]	0.11

CDT E/0-10

Speed control for EC motors

Features

- For switching fans on/off and for speed control of EC motors with 0–10 V control voltage input.



Design

- Casing made of high-quality plastic.
- Mounting junction box for wall flush mounting.
- IP40 ingress protection rating.

Control

- Switching on/off by the control knob.
- Speed control from minimum to maximum value.
- Featured with high efficiency and control accuracy.

Mounting

- Indoor wall flush mounting in a mounting box.
- Suitable for installation in standard electric junction boxes.

Options

- Mounting box EDR-E for wall surface mounting available upon separate order.

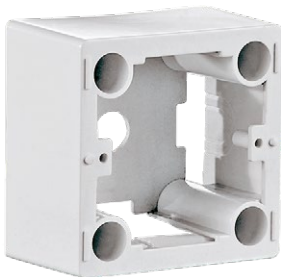

Technical data

Parameters	CDT E/0-10
Voltage [V]	10–48 DC
Control signal [V]	0–10
Maximum current [mA]	5
Overall dimensions AxBxC [mm]	78x78x63
Maximum ambient temperature [°C]	+35
Ingress Protection	IP40
Weight [kg]	0.12

Wiring diagram

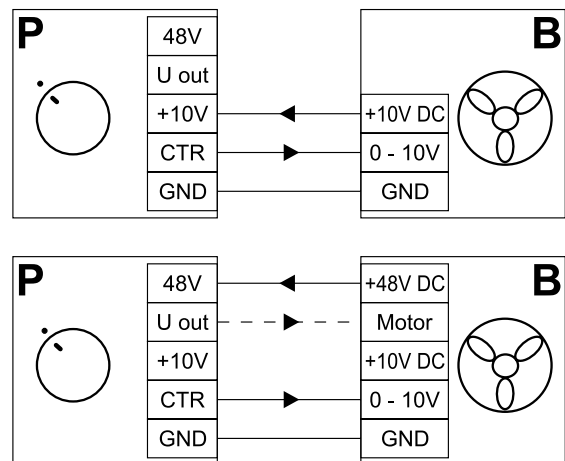

CDTE E1.8

Thyristor speed controller



Features

- For switching fans on/off and for speed control of single-phase frequency controlled motors. For ventilation systems in various premises.

Design

- Casing made of high-quality plastic.
- Surface box for mounting.
- IP40 ingress protection rating.

Control

- Switching on/off by control knob.
- Smooth speed control from minimum to maximum value. The minimum rotation speed is set by a variable resistor on the control panel.
- Several fans can be controlled from one unit provided that the total current consumption does not exceed the permissible controller current.
- Featured with high efficiency and control accuracy.

Protection

- Input circuit protected with a thermal fuse.
- Equipped with a transient filter.

Mounting

- Indoor wall mounting.

Technical data

Parameters	CDTE E1.8
Voltage 50 (60) Hz [V]	1 ~ 230
Rated current [A]	1.8
Overall dimensions AxBxC [mm]	80x80x64
Maximum ambient temperature [°C]	+35
Ingress Protection	IP40
Weight [kg]	0.11

Wiring diagram

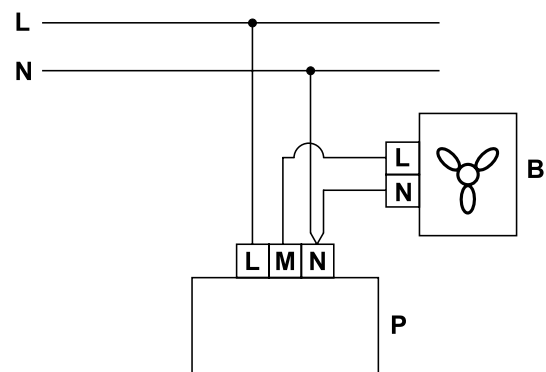

CDTE E/0-10

Speed controller for EC motors

Features

- For switching the fan on/off and for speed control of EC motors with 0–10 V control voltage input.



Design

- Casing made of high-quality plastic.
- Surface box for mounting.
- IP40 ingress protection rating.

Control

- Switching on/off by control knob.
- Speed control from minimum to maximum value.
- Featured with high efficiency and control accuracy.

Mounting

- Indoor wall mounting.

Technical data

Parameters	CDTE E/0-10
Voltage [V]	10–48 DC
Control input [V]	0–10
Overall dimensions AxBxC [mm]	80x80x63
Max. ambient temperature [°C]	+35
Ingress Protection	IP40
Weight [kg]	0.12

Wiring diagram

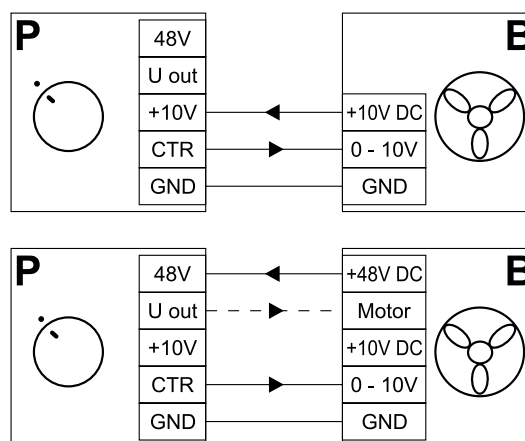

CDT1 E

Speed controller



Features

- Applied in ventilation systems for speed switching ON/OFF and speed control of single phase power-controlled motors. Several fans can be controlled synchronously in case their total current does not exceed the maximum permissible value of the controller current.

Design and control

- The controller casing is made of plastic. The control knob is equipped with the pilot light. The controller is featured with high efficiency and control accuracy. Switching is effected by means of pressing the control knob. Regulating starts from the minimum to the maximum voltage value for the fan stable running. The minimum speed is set by means of the potentiometer at the PCB. The controller is equipped with extra 230 V terminal for connection and control of the external equipment.

Protection

- Input circuit of the speed controller has a thermal fuse for overload protection. The controller is fitted with a transient filter.

Mounting

- The universal design of the controller enables its mounting either on the wall or through the wall, suitable for installation into standard round electric junction boxes.

Technical data

Parameters	CDT1 E0.5	CDT1 E1.5	CDT1 E2.5	CDT1 E4.0
Voltage [V / 50 Hz]	1 ~ 230	1 ~ 230	1 ~ 230	1 ~ 230
Minimum current [A]	0.1	0.15	0.25	0.4
Maximum current [A]	0.5	1.5	2.5	4.0
Overall dimensions LxWxH [mm]	82x82x65	82x82x65	82x82x65	82x82x65
Maximum ambient temperature [°C]	+35	+35	+35	+35
Protection rating	IP44	IP44	IP44	IP44
Weight [kg]	0.23	0.24	0.29	0.36

Wiring diagram

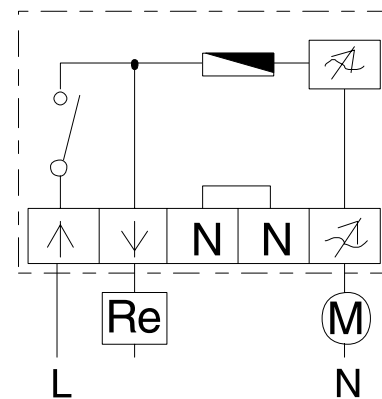
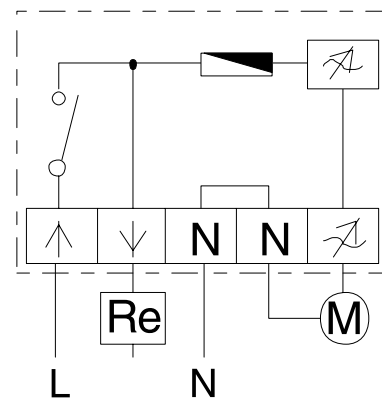

S22 / S22 Wi-Fi

Control panels

Features

- The **S22 / S22 Wi-Fi** control panels are used for control of industrial and domestic air handling units with an **S21** automation system.



Design

- Casing made of high-quality plastic.
- Glass sensor operating panel with touch buttons with light indication.
- IP40 ingress protection rating.

Control panel functions

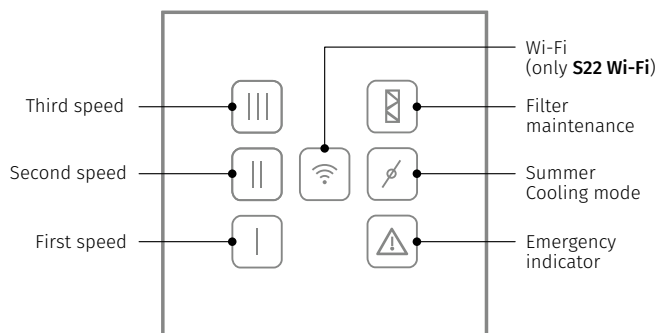

Technical data

Parameters	S22	S22 Wi-Fi
Voltage [V]	24	110–230/50 (60) Hz
Maximum current [A]	0.025	0.012
Cable type [mm ²]	4x0.25	2x0.35
Temperature range [°C]	+10...+45	+10...+45
Humidity range [%]	10–80 (no condensation)	10–80 (no condensation)
Casing material	Plastic	Plastic
Sensor surface material	Glass	Glass
SEC class	IP40	IP40
Weight [g]	190	190

Wi-Fi data

Standard	-	IEEE 802.11 b/g/n
Frequency band [GHz]	-	2.4
Transmission power [mW] (dBm)	-	100 (+20)
Network	-	DHCP
WLAN safety	-	WPA, WPA2

Installation and connection

- The **S22 / S22 Wi-Fi** control panels are suitable for flush and surface mounting.
- The delivery set includes mounting boxes for flush and surface mounting.
- Connection of the control panel is carried out according to the User's manual of the unit.

Overall dimensions [mm]

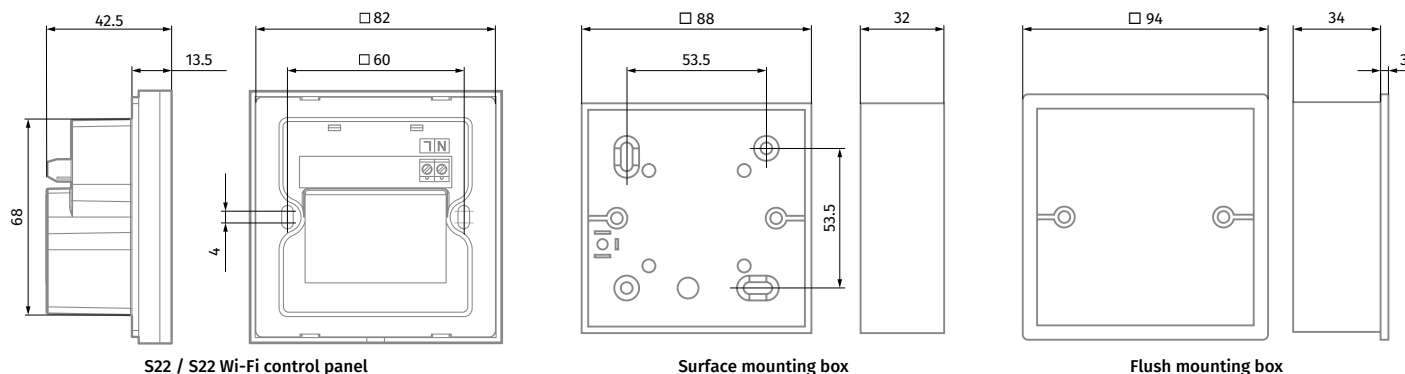

S25

Control panel with a sensor display



Features

- For control of industrial and domestic air handling units with an S21 automation system.

Design

- Casing made of high-quality plastic.
- The panel is equipped with a touch LCD display.
- Dust and moisture protection rating – IP20.

Control functions

- Speed switching.
- Filter replacement indication (according to timer or filter clogging differential pressure switch readings).
- Alarm indication: full description of the alarm.
- Week-scheduled operation.
- Bypass (automatic and manual).
- Timer.
- Boost.
- Fireplace.
- Freeze protection.
- Control of electric and water preheaters and reheaters.
- Cooler connection.
- Supply air temperature control.
- Control of humidity, CO₂, VOC, PM2.5.
- Fire alarm connection.

Mounting

- Designed for indoor installation.
- Connection and mounting of the control panel are carried out according to the User's manual of the unit.

Technical data

Parameters	S25
Voltage DC [V]	12–32
Current at 24 VDC [A]	0.1
Power cable (10 m), type	4 × 0.25 mm ²
Temperature range [°C]	-10...+45
Humidity range [%]	10 – 80 (no condensation)
Ingress Protection	IP20

Overall dimensions [mm]

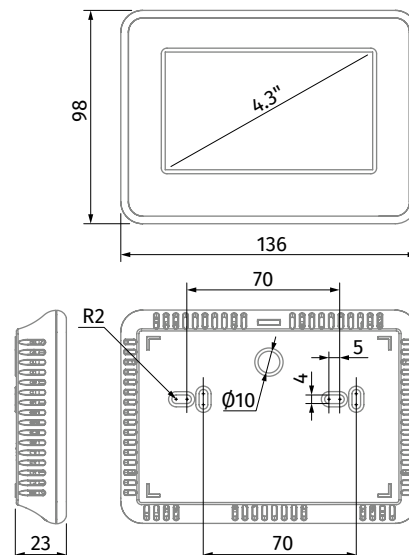

DPWQ30600

VOC sensor

Features

- Self-calibrating processor-controlled VOC sensor provides air quality measurement.
- The device is used for quantitative assessment of indoor air saturation with contaminants (e.g. cigarette smoke, expired air, and solvent and detergent vapours).
- Enables setting the sensitivity level relative to an expected maximum air pollution level.
- Enables on-demand ventilation which results in considerable energy savings as air is exchanged only upon reaching the pre-set level of air pollution.



Design

- DPWQ30600** VOC sensor has 2 analogue outputs: 0–10 V and 4–20 mA. An analogue output provides for stepless fan speed control (requires an EC motor fan or a frequency drive).
- With stepless control the fan speed is changed in proportion to air quality changes.

Mounting

- The sensor is mounted onto a wall or a mounting box inside the serviced space. The unit is powered from a 24 VAC/VDC low-current electric mains.

Technical data

Parameters	Values
Power source	24 VAC/VDC
Gas analyser	VOC sensor
Measurement range	0–100 % air quality
Output signal	0–10 V
Measurement precision	±20 %
Operating conditions	0–50 °C; 10–90 % relative humidity without condensate
Protection class	IP30
Dimensions	79x81x26 mm

Connection diagram

KOMFORT Roto EC D/S

1	2	3	4	5	6	7	8	9	10	11	12	13	14	15	16	17	18	19	20	21	22	23
GND	R+	R-	GND~	~24V	0-10V	GND	~24V	NO	NO	NO	NO	2	1	2	1	TS1	TS1	PE	N	L	N	L1

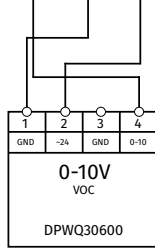

Civic EC L

1	2	3	4	5	6	7	8	9			
PE	N	L	NC	L	L	L	~24V	~24V	GND	GND	B5

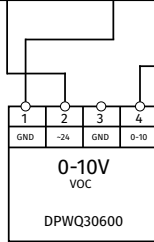

Civic EC D

1	2	3	4	5	6	7	8	9	10	11	12	13				
GND	0-10V	TACH	0-10V	TACH	NO	GND	GND	~24V	~24V	NO	L	L	L	L	L	0-10V

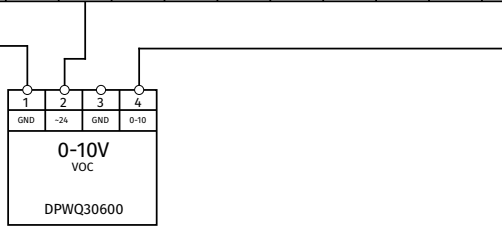

DPWC11200

Humidity and temperature sensor

Features

- The DPWC sensor is intended for temperature, humidification and/or dehumidification control in ventilation, air conditioning and heating systems.



Design

- The **DPWC11200** humidity and temperature sensor has 2 analogue outputs: 0–10 V and 4–20 mA. An analogue output provides for stepless fan speed control (requires an EC motor fan).
- With stepless control the fan speed is changed in proportion to the humidity and temperature level. Being equipped with both relay and analogue outputs the sensor is compatible with most every existing ventilation systems.

Mounting

- The sensor is mounted onto a wall in the serviced space. The unit is powered from a 24 VAC/VDC low-current electric mains.

Technical data

Parameters	Values
Power source	8–30 VDC / 12–24 VAC
Analogue outputs	0–10 V and 4–20 mA
Temperature measurement precision	±1.2 °C
Humidity measurement precision	±3 % RH
Operating conditions	-10–60 °C; 10–90 % humidity without condensate
Protection class	IP30
Dimensions	127x80x30 mm

Connection diagram

Komfort Roto EC D/S

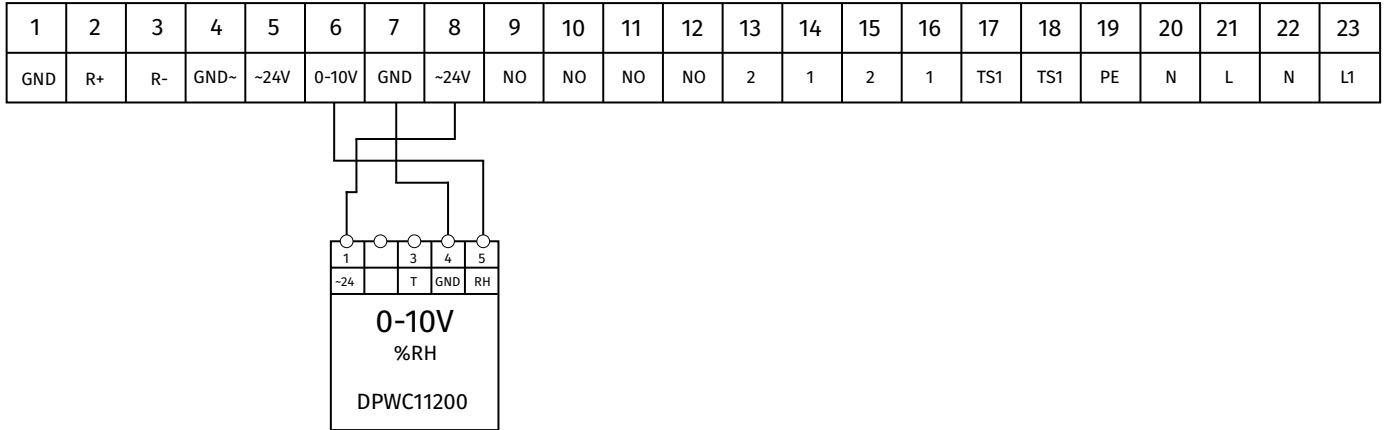

Civic EC L

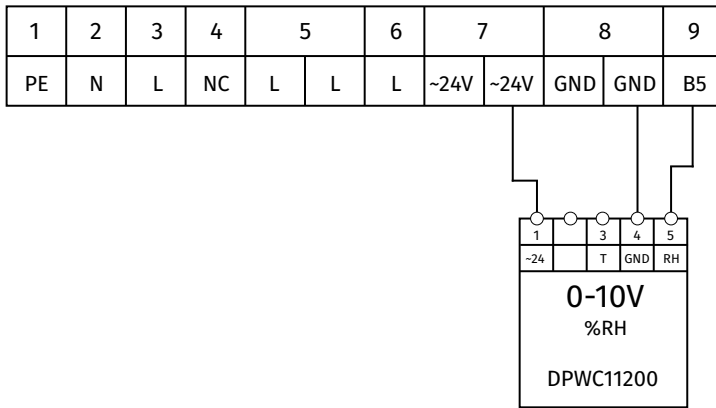

Civic EC D

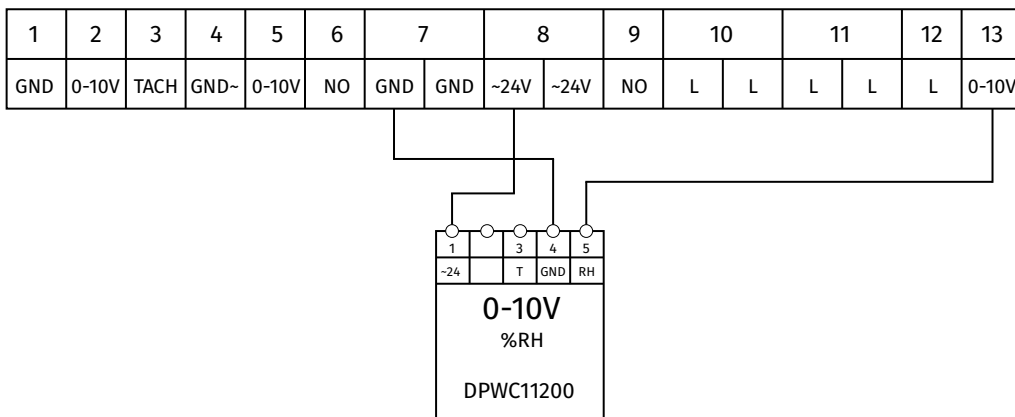

DPWQ40200

CO₂ sensor

Features

- Self-calibrating sensor with microprocessor control for measuring carbon dioxide content in the air within the range from 0 to 2.000 million⁻¹ (parts per million).



Design

- DPWQ40200** CO₂ sensor has 2 analogue outputs: 0–10 V and 4–20 mA. An analogue output provides for stepless fan speed control (requires an EC motor fan or a frequency drive).
- With stepless control the fan speed is changed in proportion to carbon dioxide concentration changes. The CO₂ content in the air is measured by means of a non-dispersive infrared analyser (NDIR).

Mounting

- The sensor is mounted onto a wall or a mounting box inside the serviced space. The unit is powered from a 24 VAC/VDC low-current electric mains.

Technical data

Parameters	Values
Power source	24 VAC/VDC
Gas analyser	optical (NDIR)
CO ₂ measurement range	0–2.000 million ⁻¹ (parts per million) of CO ₂
CO ₂ output signal	0–10 V
CO ₂ measurement precision	± 30 million ⁻¹ (parts per million), ± 5 % of maximum value
Operating conditions	0–50 °C; 10–90 % relative humidity without condensate
Protection class	IP55
Dimensions	95x97x30 mm

Connection diagram

KOMFORT Roto EC D/S

1	2	3	4	5	6	7	8	9	10	11	12	13	14	15	16	17	18	19	20	21	22	23
gnd	R+	R-	GND~	~24V	0-10V	GND	~24V	NO	NO	NO	NO	2	1	2	1	TS1	TS1	PE	N	L	N	L1

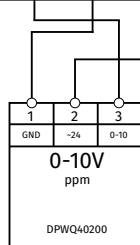

Civic EC L

1	2	3	4	5	6	7	8	9			
PE	N	L	NC	L	L	L	~24V	~24V	GND	GND	B5

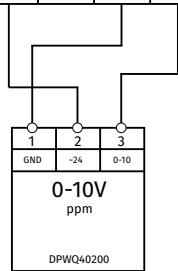

Civic EC D

1	2	3	4	5	6	7	8	9	10	11	12	13				
GND	0-10V	TACH	0-10V	TACH	NO	GND	GND	~24V	~24V	NO	L	L	L	L	L	0-10V

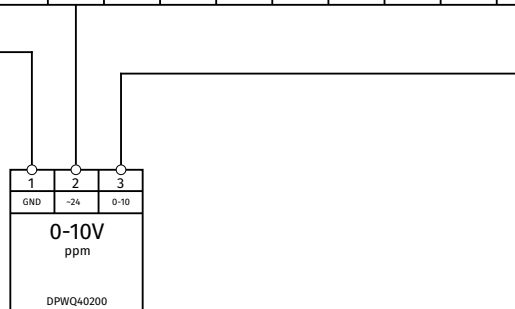

CD-1 / CD-2

CO₂ sensors

Features

- Indoor carbon dioxide concentration measurement.
- Air flow control depending on CO₂ concentration.
- Efficient energy saving device.



Design

- The sensor has two separate outputs, a normally opened dry relay contact and an analogue output 0–10 V that is adjustable fo 2–10 V/ 0–20 mA/4–20 mA.
- The relay output is used to turn the fan on/off depending on indoor CO₂ concentration and the analogue output is used for smooth fan speed control for a fan with EC motor or a fan with extra speed controller with 0–10 V input. In case of smooth fan speed control the fan speed varies proportionally to carbon dioxide emissions.
- Due to the relay and analogue outputs the sensor is compatible with any ventilation system. The self-calibration system ensures reliable sensor operation during the sensor service life.

Modifications

- **CD-1:** integrated LED lights for indication of CO₂ concentration and a touch button for operation mode switching (mode 1: on, mode 2: off, mode 3: operation according to CO₂ concentration). The button is used to turn the fan on or turn it off when CO₂-based ventilation is not required.
- **CD-2:** no integrated LED-lights and no touch button. This model is recommended for premises requiring permanent ventilation as school classes and other public premises.

Mounting and power supply

- Wall surface mounting.
- 24 VAC low current power supply.
- The sensor has a socket for AT power unit offered as an accessory (AT-220/25 or AT-120/25 models).



Technical data

Parameters	Value
Power supply / Consumption	24 VAC (50 (60) Hz ± 10 %), 24 VDC/1.6 W Max
Gas sensing element	Non-dispersive infrared detector (NDIR) with self-calibration system
CO ₂ -measuring range	0–2.000 ppm (parts per million)
Accuracy at 25 °C, 2.000 ppm	±30 ppm + 3 % of reading
Response time	max. 2 min
Warm up time for each turning-on	2 hours (first time), 2 minutes (operation)
Analogue output	0–10 VDC (default), 4–20 mA selectable by jumpers
On/Off output	1X2A switch load Four set points selectable by jumpers
6 LED lights for CO ₂ concentration indication (for CD-1 model)	1st green indicator lights when CO ₂ concentration is below 600 ppm 1st and 2nd green indicators light when CO ₂ concentration is 600–800 ppm 1st yellow indicator lights when CO ₂ concentration is 800–1200 ppm 1st and 2nd yellow indicators light when CO ₂ concentration is 1200–1400 ppm 1st red indicator lights when CO ₂ concentration is 1400–1600 ppm 1st and 2nd red indicators light when CO ₂ concentration is above 1600 ppm
Operating conditions / Storage regulations	0–50 °C; 0–95 % RH non condensing/0–50 °C
Weight/Dimensions	0.12 kg/100 mm x 80 mm x 30 mm

Sensor wiring diagram

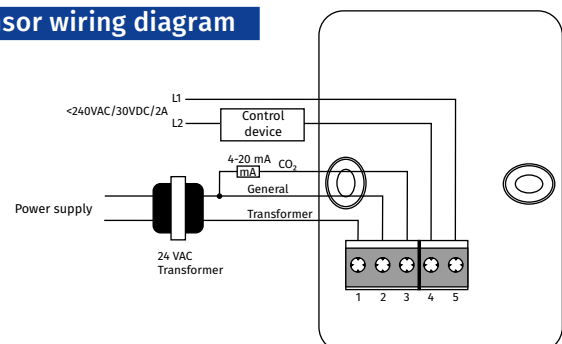

HR-S

Electro-mechanical humidistats



Purpose

- The humidistat is designed for controlling humidification and/or dehumidification in ventilation, air conditioning and heating systems.
- Can also be used to alarm when the humidity exceeds or falls below a pre-set level.

Design

- The single-stage humidistat HR-S uses a synthetic element as sensor medium. The synthetic element stretches as the humidity increases and shrinks as the humidity decreases.

Mounting

- The humidistat is designed for indoor mounting on the wall surface.

Humidistat wiring diagram

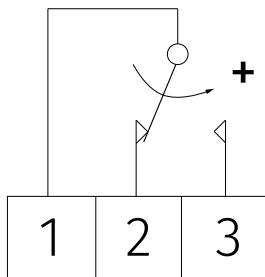

Humidification
Dehumidification

Closing contact between terminals 1 and 2
Closing contact between terminals 1 and 3

Technical data

Parameters	HR-S
Switch contact	250 VAC, 5 A
Moisture [%]	20–90
Casing material	Polycarbonate
Temperature range [°C]	0–40
Mounting	Wall surface mounting
Ingress protection	IP30
Dimensions [mm]	86x86x30

FS2

Humidity sensor



Features

- The **FS2** humidity sensor is designed to control humidity in ventilation, air conditioning and heating systems.

Overall dimensions [mm]

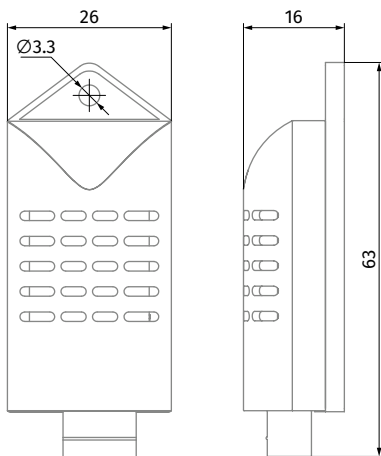

Compatibility

- The HV2 humidity sensor is compatible with air handling units with an S14 or S21 automation system.

Mounting

- Possible mounting options are shown below::

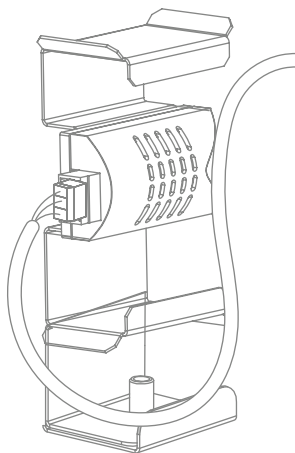

On the bracket in the exhaust air duct of the unit

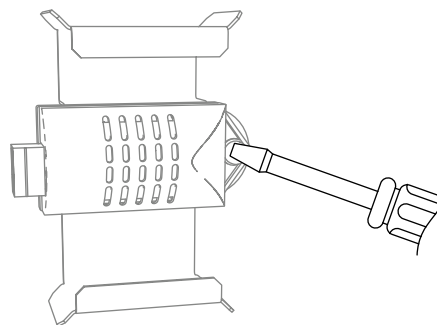

In the exhaust air duct of the unit on a threaded rivet or plastic support

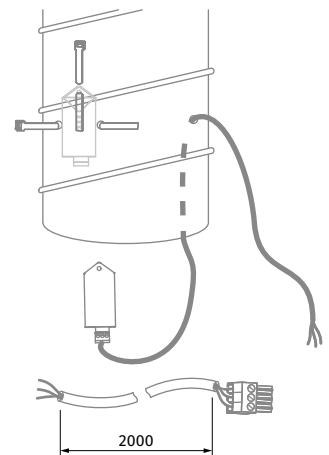

In the exhaust air duct upstream of the heat exchanger (only for KOMFORT EC S(B) 160(-E))

Find more details on the installation of the FS2 humidity sensor in the installation instructions.

BELIMO CM230 / CM24

Electric actuators

Features

- For controlling air dampers with cross section up to 0.4 m² installed in various ventilation and air conditioning systems.



Design

- The electric actuator is provided with a 2 Nm actuating torque and an overload protection.
- The actuator is installed directly on the air damper shaft.
- The angle of rotation is adjusted by mechanical end stops.

Control

- The air flow control damper can be controlled by means of the three-point or open-close controlling.

Wiring diagram

Open-Close controlling

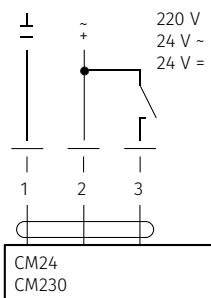

3 point controlling

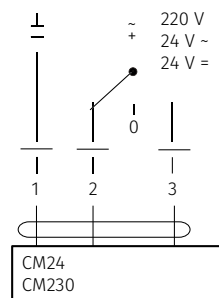

Technical data

Parameters	CM24	CM230
Voltage	24 V ~ 50 (60) Hz, 24 V=	230 V ~ 50 (60) Hz
Nominal voltage range [V]	19.2...28.8 ~ 19.2...28.8 =	85...265 ~
Rated power [VA]	1	2
Power consumption in operation / at rest [W]	0.5 / 0.5	1 / 1
Connecting cable	1 m long, 3 x 0.75 mm ²	
Positioning accuracy	± 5 %	± 5 %
Direction of rotation	determined by terminal connection	
Torque [Nm]	2 (at nominal voltage)	
Angle of rotation: - no end stop - with an end stop	endless fixed 315° / adjustable 0...287.5° in 2.5° increments	
Swing time	75 sec / 90°	75 sec / 90°
Position indication	mechanical	mechanical
Ingress protection rating	IP54 at any mounting position	
Electrical protection class	III low voltage II totally insulated	
Operation temperature [°C]	-30...+50	-30...+50
Storage temperature [°C]	-40...+80	-40...+80
Ambient humidity	95 %, no condensation	
Noise level [dBA]	35	35
Maintenance	not required	not required
Weight [kg]	0.13	0.13

Overall dimensions [mm]

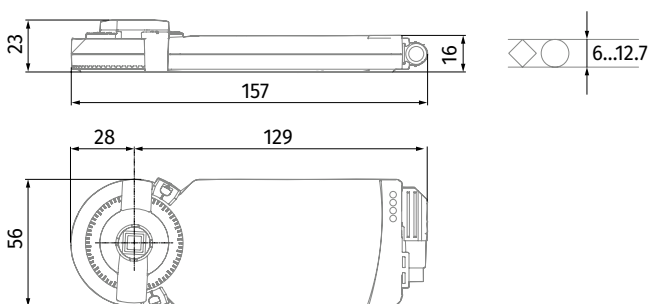

BELIMO TF230 / TF24

Electric actuators



Features

- For controlling air dampers with cross section up to 0.4 m² installed in various ventilation and air conditioning systems and performing protection functions.

Design

- The electric actuator is provided with a 2 Nm actuating torque and an overload protection.
- The actuator is installed directly on the air damper shaft.
- The actuator is equipped with a return spring, which moves the damper to its operating position while tensioning the return spring at the same time. In case of power supply cut-off, the damper moves back to its safe position by the spring energy.
- The angle of rotation is adjusted by mechanical end stops.

Wiring diagram

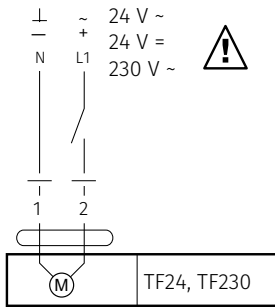

For TF24: connection via a power transformer
 For TF230: after disconnection from power supply the contacts opening gap must be within 3 mm.

Several electric actuators may be parallel connected with respect to the power

Overall dimensions [mm]

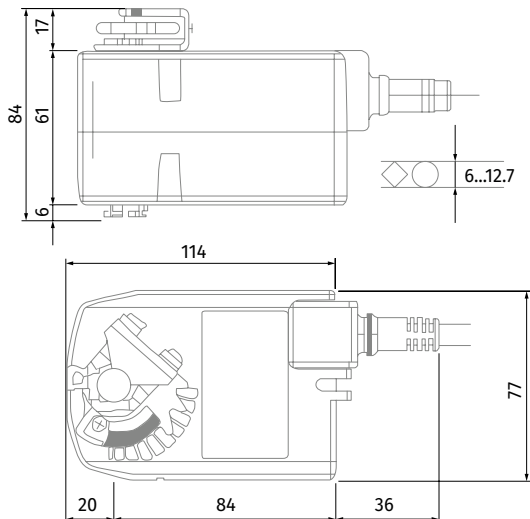

Technical data

Parameters	TF24	TF230
Voltage	24 V ~ 50 (60) Hz, 24 V=	230 V ~ 50 (60) Hz
Nominal voltage range [V]	19.2...28.8 ~ 21.6...28.8 V=	85...265 ~
Rated power [VA]	4 (max. I 5.8 A at t = 5 ms)	4 (max. I 150 mA at t = 10 ms)
Power consumption in operation / at rest [W]	2 / 1.3	2 / 1.3
Connecting cable	1 m long, 2 x 0.75 mm ²	
Direction of rotation	determined by L/R positioning	
Torque (motor / spring) [Nm]	2 (at nominal voltage) / 2	
Angle of rotation:	max. 95°, adjustable 37...100 % with a mechanical end stop	
Swing time (motor / spring) [sec]	40...75 (0...2 Nm) / < 25 bei -20...50 °C	
Service life	60 000 switching operations	
Ingress protection rating	IP42	IP42
Electrical protection class	III low voltage II totally insulated	III low voltage II totally insulated
Operation temperature [°C]	-30...+50	-30...+50
Storage temperature [°C]	-40...+80	-40...+80
Ambient humidity	95 %, no condensation	
Noise level (motor/ spring) [dBA]	50 / ≈ 62	50 / ≈ 62
Maintenance	not required	not required
Weight [kg]	0.6	0.6

ELECTRIC ACTUATORS

BELIMO LF230 / LF24

Electric actuators

Features

- For controlling air dampers with cross section up to 0.8 m² installed in various ventilation and air conditioning systems and performing protection functions.



Design

- The electric actuator is provided with a 4 Nm actuating torque and an overload protection.
- The actuator is installed directly on the air damper shaft.
- The actuator is equipped with a return spring, which moves the damper to its operating position while tensioning the return spring at the same time. In case of power supply cut-off, the damper moves back to its safe position by the spring energy.
- The angle of rotation is adjusted by mechanical end stops.

Wiring diagram

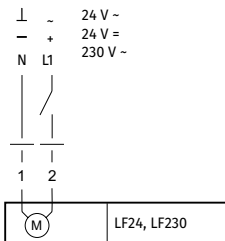

Warning!
For LF24: connection via a power transformer

For LF230: after disconnection from power supply the contacts opening gap must be within 3 mm

Several electric actuators may be parallel connected with respect to the power

Technical data

Parameters	LF24	LF230
Voltage	24 V ~ 50 (60) Hz, 24 V=	230 V ~ 50 (60) Hz
Nominal voltage range [V]	19.2...28.8 ~ 21.6...28.8 V=	198...264 ~
Rated power [VA]	7 (max. I 5.8 A at t = 5 ms)	7 (max. I 150 mA at t = 10 ms)
Power consumption in operation / at rest [W]	5 / 2.5	5 / 3
Connecting cable	1 m long, 2 x 0.75 mm ²	
Direction of rotation	determined by L/R positioning	
Torque (motor / spring) [Nm]	4 (at nominal voltage) / 4	
Angle of rotation	max. 95°, adjustable 37...100 % with a mechanical end stop	
Swing time (motor / spring) [sec]	40...75 (0...4 Nm) / ~ 20 at -20...50 °C	
Service life	60 000 switching operations	
Ingress protection rating	IP54 (installation with cable downwards)	
Electrical protection class	III low voltage II totally insulated	III low voltage II totally insulated
Operation temperature [°C]	-30...+50	
Storage temperature [°C]	-40...+80	
Ambient humidity	95 %, no condensation	
Noise level (motor/ spring) [dBA]	50 / ≈ 62	50 / ≈ 62
Maintenance	not required	
Weight [kg]	1.4	1.4

Overall dimensions [mm]

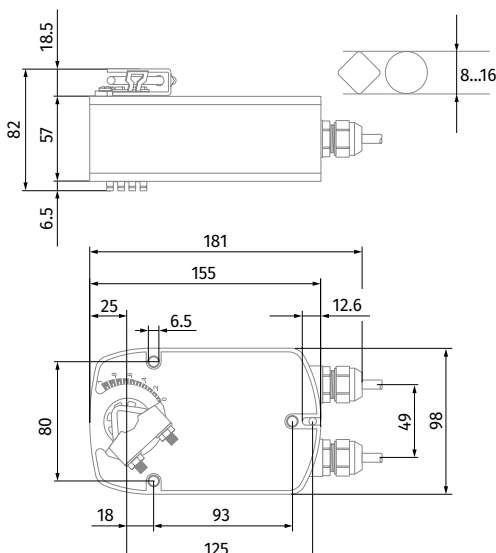

CP-2

Drain pump

Features

- The drain pump provides extraction and discharge of condensate that may form in the heat exchanger during heat recovery.



Design

- 1 – condensate water inlet
- 2 – air intake fitting for Ø 4x6 hose
- 3 – condensate outlet fitting for Ø 4x6 hose
- 4, 8 – fitting for Ø 4x6 connecting hose
- 5 – fitting for a drain pipe for Ø 4x6 hose
- 6 – removable terminal block
- 7 – mounting plate
- 9 – pump lock
- 10 – removable electric cable socket

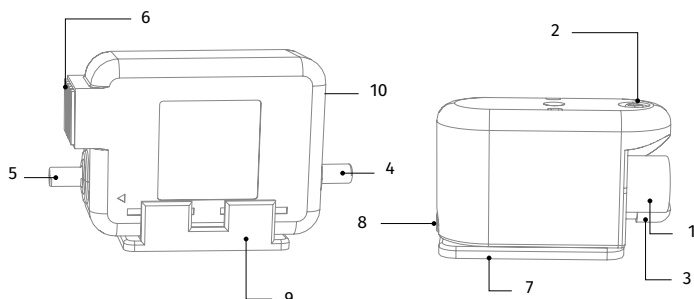

Overall dimensions [mm]

Model	Ø D2	Ø D1	A	A1	A2	H	H1	L	L1
CP-2	18	5	68	68	82	55	38	32	30

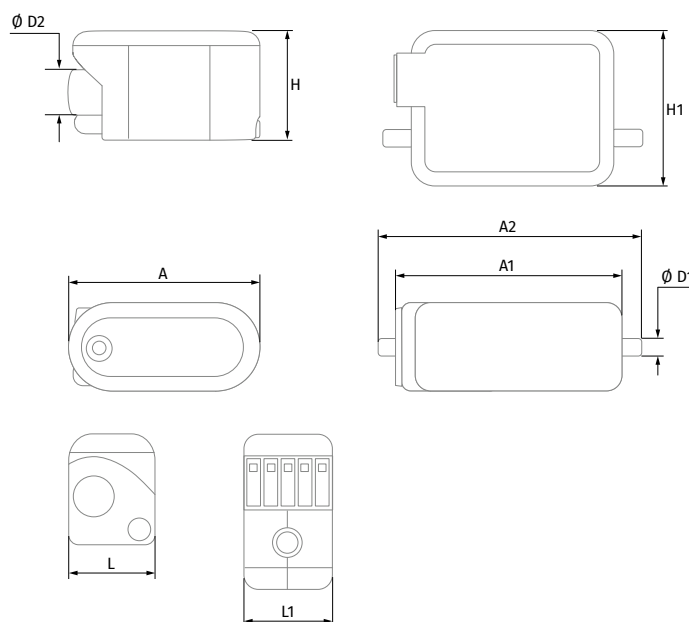

Mounting

- For CP-2 pump both horizontal and vertical installation is possible. The pump drain pan must be installed in the horizontal position only, in compliance with the user's manual.

Technical data

Model	CP-2
Water flow [l/h]	7
Water suction head [m]	2
Vertical pressure head [m]	7
Voltage [V/Hz]	230/50
Noise level [dBA]	21
Power [W]	19
C – NO signal contact parameters [A]	8

SFK 20x32

Hydraulic syphon for condensate drainage

Features

- The hydraulic syphon kit for water heat exchangers SFK 20x32 is designed for condensate drainage from heat exchangers and coolers in ventilation and air conditioning systems.
- The syphon must be connected to a drain pan pipe \varnothing 18 mm.



Design

- When the condensate is drained from the ventilation unit, it passes the drain pipe through the flexible PVC hose, the connection coupling and reaches the syphon with the mechanical locking device that does not let sewage system odours out after the hydraulic seal dries out. Then the condensate is moved to the sewage system.
- The SFK 20x32 kit consists of:
 - Coupling 32/32
 - Rubber sleeve 32/20
 - Syphon
 - PVC hose 15x2 of 1000 mm length

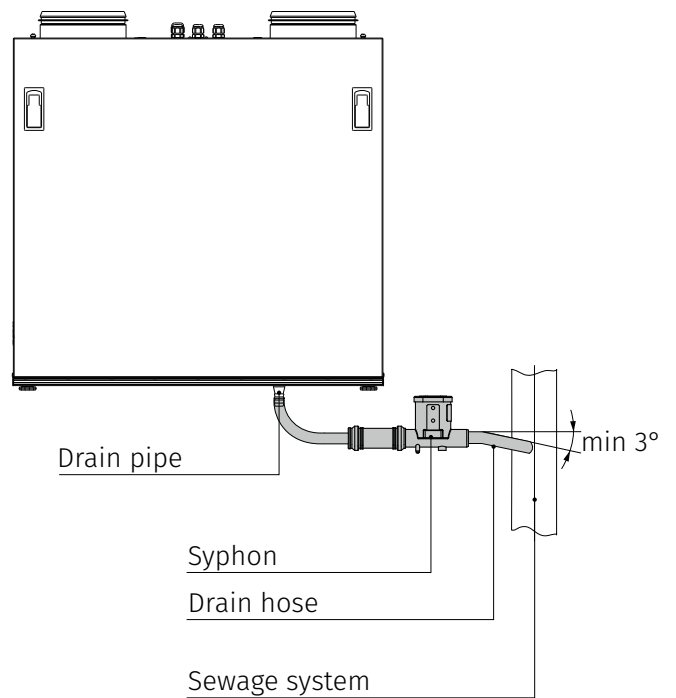

CONDENSATE DRAINAGE

Overall dimensions [mm]

Model	D	B	L
SFK 20x32	32	103	1000

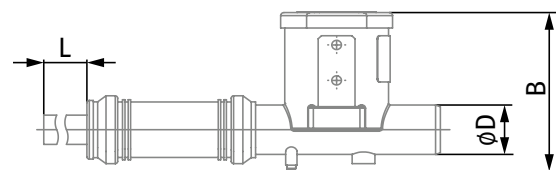

WMG

Water mixing unit

Features

- Smooth heating medium flow regulation and supply air set temperature maintaining in ventilation systems with water heating or cooling coils.
- Compatible with the WKH duct water heating coils and the KWK duct cooling coils.
- Compatible with all water heating or cooling coils installed in BLAUBOX supply units and KOMFORT air handling units.



Design

- The water mixing unit consists a circulation pump, a three-way electrically actuated heat medium control valve and a recirculation pipe.
- The three-way valve is designed for smooth mixing of the heat medium stream from the heating (cooling) system and the return heat medium in a required proportion to regulate the heat medium temperature supplied to the water heating or cooling coils.
- The three-way way is actuated with a control 0-10 V signal from the ventilation control system.
- The mixing unit is rated for heat medium operating pressure in the mixing set 10 bar.

Connection to water circuit

- Connection of the mixing unit to the water heating or cooling coils and to the water heating/cooling network through the pipes or flexible hoses of respective diameter, refer to the technical data table.
- In case of applying flexible hoses the mixing unit must be rigidly fixed.
- While installing the mixing unit the motor shaft must be installed horizontally. No mechanical loads from the pipes are allowed.

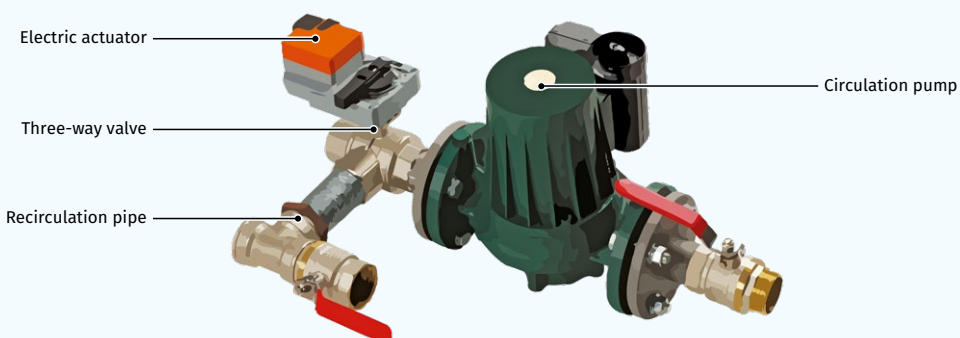

Designation key

Series	Connected spigot diameter [in]	Heat medium transmission factor (Kvs)
WMG	3/4; 1; 1 1/4; 1 1/2; 2	4; 6; 10; 16; 25; 40

Overall dimensions [mm]

Model	B	H	H1	L
WMG 3/4-4	150	290	180	460
WMG 3/4-6	150	290	180	460
WMG 1-6	175	320	210	490
WMG 1-10	175	320	210	490
WMG 1 1/4-10	175	355	240	500
WMG 1 1/4-16	175	355	240	500
WMG 1 1/2-16	266	420	255	610
WMG 1 1/2-25	266	420	255	610
WMG 2-25	312	474	290	660
WMG 2-40	312	474	290	660

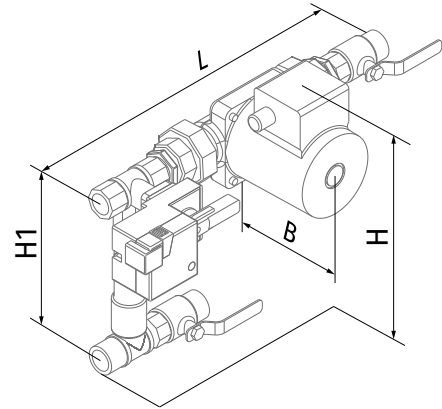

Recommended connection to water network

- T1 and T2: heat medium supply and return pipeline
- P1 and P2: water pressure gauges for supply and return pipes
- 1: mixing unit
- 2: water heater
- 3: electrically actuated three-way valve
- 4: circulation pump
- 5: shut-off valve
- 6: supply and return pipes from the heat distribution system to the water heater
- 7: non-return valve
- 8: balancing valve
- 9: coarse filter

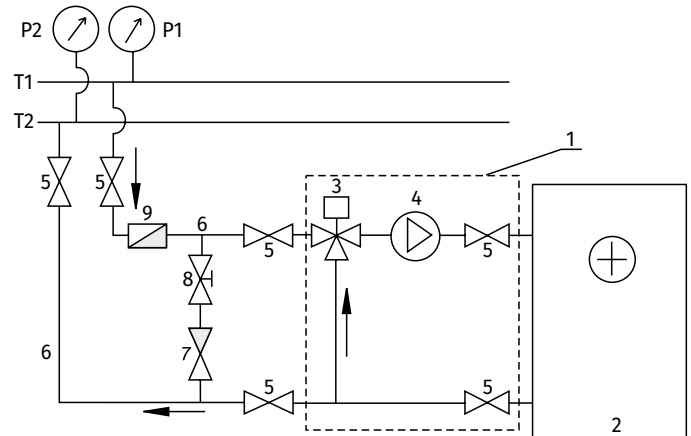

Technical data

Parameters	WMG 3/4-4	WMG 3/4-6	WMG 1-6	WMG 1-10	WMG 1 1/4-10	WMG 1 1/4-16	WMG 1 1/2-16	WMG 1 1/2-25	WMG 2-25	WMG 2-40
Circulation pump	DAB VA65/180		DAB A50/180XM		DAB A56/180XM		DAB BPH 120/250.40M		DAB BPH 120/280.50T	
Three-way valve control way	0...10 V	0...10 V	0...10 V	0...10 V	0...10 V	0...10 V	0...10 V	0...10 V	0...10 V	0...10 V
Electrically actuated three-way valve	R317	R318	R322	R323	R329	R331	R338	R339G	R348	R349G
Three-way valve actuator Belimo	LR24A-SR	LR24A-SR	LR24A-SR	LR24A-SR	LR24A-SR	LR24A-SR	NR24A-SR	SR24A-SR	NR24A-SR	SR24A-SR
Connection type	Threaded connection						Flanged connection			
Three-way valve nominal diameter	DN 20	DN 20	DN 25	DN 25	DN 32	DN 32	DN 40	DN 40	DN 50	DN 50
Three-way valve heat medium transmission factor (Kvs*)	4	6.3	6.3	10	10	16	16	25	25	40
Max. mixing unit flow capacity [m³/h]	2.3	3.0	4.1	6.0	6.8	9.0	11.0	14.0	21.0	27.0
Developed head [kPa]	57	57	57	57	62	62	110	110	115	115
Connected spigot diameter	3/4"	3/4"	1"	1"	1 1/4"	1 1/4"	1 1/2"	1 1/2"	2"	2"
Transported heat medium temperature [°C]	-10...+110	-10...+110	-10...+110	-10...+110	-10...+110	-10...+110	-10...+120	-10...+120	-10...+120	-10...+120
Max. glycol content in the transported heat medium [%]	30	30	30	30	30	30	30	30	30	30
Number of pump speeds	3	3	3	3	3	3	3	3	3	3
Phase / Pump supply voltage / 50 Hz [V]	1 ~ 230	1 ~ 230	1 ~ 230	1 ~ 230	1 ~ 230	1 ~ 230	1 ~ 230	1 ~ 230	3 ~ 400	3 ~ 400
Max. pump power [W]	78	78	184	184	271	271	510	510	898	898
Weight [kg]	4.1	4.1	6.8	6.8	7.4	7.4	23.0	23.0	31.0	31.0

Heat medium transmission factor $K_{vs} = \frac{V_{100}}{\sqrt{\frac{\Delta p_{V100}}{100}}}$, where Δp_{V100} – pressure loss when the heat medium valve is fully opened.
 V_{100} – rated heat medium flow at Δp_{V100} .

Mixing unit calculation diagram

Mixing unit selection: find the required heat medium flow through the heating (cooling) unit as well as heat medium pressure drop (available head). These parameters are determined using the heating or cooling unit calculation diagram for each water heating or cooling unit.

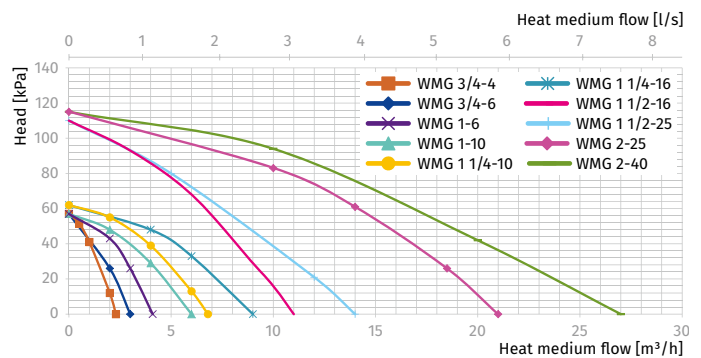



Blauberg Ventilatoren GmbH
Aidenbachstr. 52
D-81379 Munich

info@blaubergventilatoren.de
www.blaubergventilatoren.de

Technical changes reserved.
Illustrations and texts are non-binding.

02/2021