



FIRE SAFETY DAMPERS

SMOKE EXTRACTION PRODUCT CATALOGS



MEDIUM PRESSURE AXIAL FANS AND AXIAL SMOKE EXTRACTION FANS



CENTRIFUGAL SMOKE EXTRACTION FANS



SMOKE EXTRACTION VENTILATION FOR PARKING PREMISES



FIRE SAFETY DAMPERS



60 Hz



MEDIUM PRESSURE AXIAL FANS AND AXIAL SMOKE EXTRACTION FANS



60 Hz



SMOKE EXTRACTION VENTILATION FOR PARKING PREMISES



CONTENTS

Smoke extraction systems of buildings	2
RSKE / RSKM. Multi-purpose fire safety smoke dampers	6
BSK1. Fire-resisting dampers	20
BSK2. Fire-resisting dampers	28
BSK. Fire-resisting dampers	38
Accessories for fire safety dampers	44

SMOKE EXTRACTION SYSTEMS OF BUILDINGS

Smoke control is a complex process involving smoke extraction and fresh air supply by the supply and exhaust ventilation system of buildings in order to ensure safe evacuation of people in case of a fire in any of the spaces.

The smoke control system of a building or structure must ensure protection of people along the evacuation paths from the fire hazards during the time required for the personnel evacuation procedure or the entire period of fire development and control by means of extracting the combustion and thermal decomposition products and/or preventing their spreading. A smoke control system is an integral element of a utility system design including all kinds of high-rise buildings, shopping and office centres, hospital facilities, production and storage spaces etc. as well as underground structures.

According to conclusive evidence the majority of mortalities in a fire are caused by poisoning from carbon monoxide and other combustion products. Carbon monoxide is one of the most toxic smoke components. It is carbon monoxide poisoning that accounts for 80 % of the fire accident causes. Fires in closed spaces where oxygen supply is limited are especially prone to intensive carbon monoxide generation. Carbon monoxide poisoning occurs when its concentration in the inspiratory air exceeds 0.08 %. Concentration growth up to 0.32 % results in paralysis and loss of consciousness (with imminent death in about 30 minutes). Concentrations in excess of 1.2 % lead to loss of consciousness after 2-3 aspirations whereas another 2-3 minutes are fatal. Smoke spreads much faster than fire, therefore causing loss of consciousness and cardiac arrest before the victim reaches the safety outdoors. Furthermore, smoke contamination impacts spatial orientation forcing the victim to negotiate obstacles by touch and, quite often, to diverge from the escape paths.

FIRE IN A BUILDING WITHOUT A SMOKE CONTROL SYSTEM

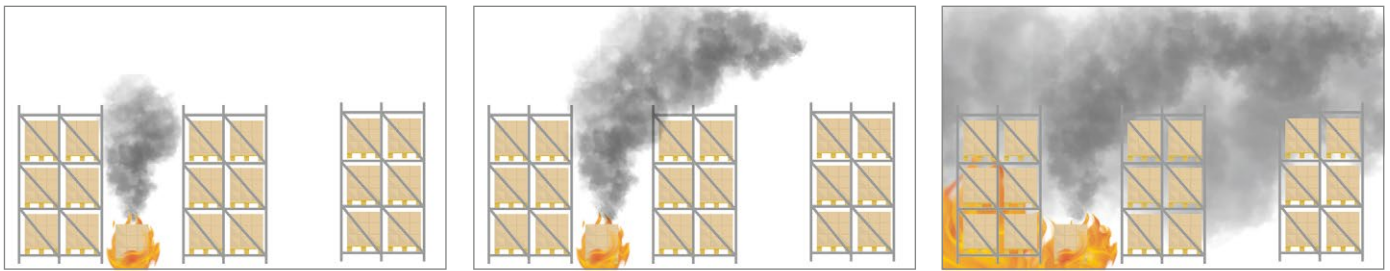

FIRE IN A BUILDING EQUIPPED WITH A SMOKE CONTROL SYSTEM

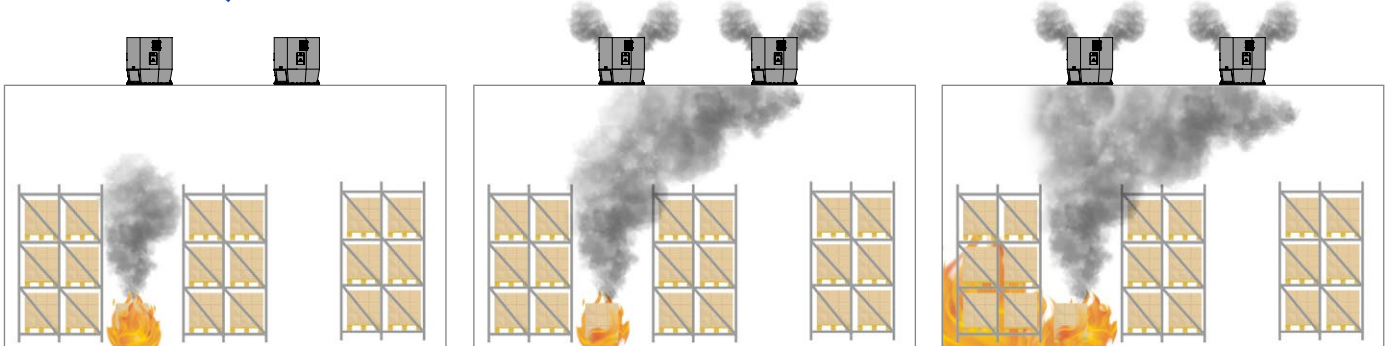

SMOKE CONTROL SYSTEM SOLUTION

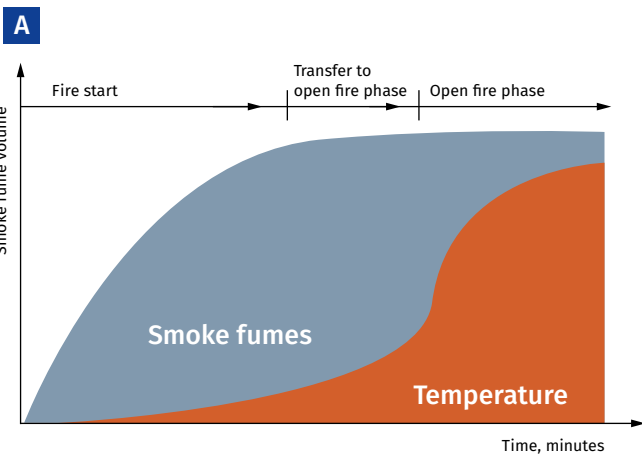

The A chart clearly shows that at the fire origin where no fire control systems are present, the smoke fume volume rapidly becomes critical.

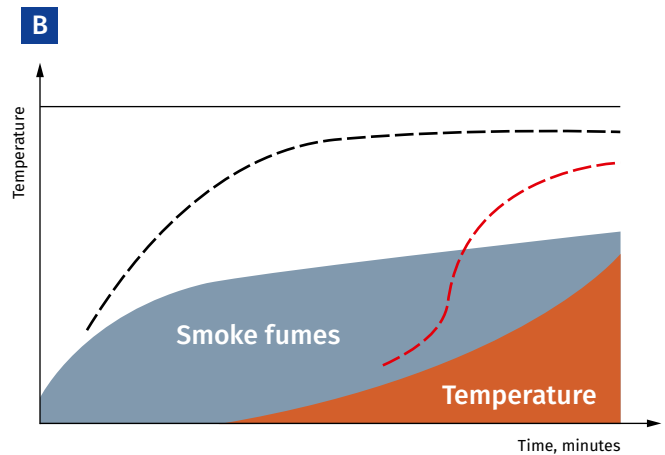

However, the B chart shows that a fire control extraction system helps to significantly reduce the content of smoke in the gas environment which remains below the safety threshold during the entire duration of fire.

SMOKE CONTROL SYSTEM FUNCTIONS:

- o Prevention of smoke spreading from the ignition source.
- o Prevention of smoke transfer to the evacuation paths (maintaining acceptable conditions for the people being evacuated from the building).
- o Maintaining a microclimate beyond the ignition source area to enable normal operation of fire-fighting teams.
- o Protecting life of people in the building.
- o Protecting property against damage.

DESIGN:

- o The smoke control system elements are integrated at the initial phase of the building (residential complex, office block, warehouse facility etc.) construction. These communications must be contained in the design engineering documents specific to the life-support system. All the works specific to the design and installation of smoke control systems are strictly covered by the applicable construction standards and regulations.
- o Smoke control plays a paramount role in making a building safe and ensuring compliance with any and all fire safety standards and regulations. Purpose-built smoke exhaust duct lines provide additional safety and enable easy evacuation of people using corridors and stairs which are completely free of hazardous fumes.
- o Smoke control is a complex process affected by numerous conditions and factors, and, therefore, the design of such communication systems requires an expert qualification. Smoke control systems must only be designed by professionals since any disregard of the commonly accepted state regulations may lead to human casualties.

SMOKE CONTROL SYSTEMS CONSIST OF:

- o **Smoke extraction fans** which are used in emergency exhaust ventilation systems for forced extraction of smoke and heated gases and simultaneous transfer of heat generated by the fire away and beyond the limits of the serviced spaces where the ignition occurs. Such units are used in production, public, residential, administrative and other spaces. Such fans are capable of handling smoke and air mixtures with temperatures up to 600 °C.
- o **Pressurization fans** are intended for creating a positive pressure differential in lift shafts, at landings and in air-lock corridors to prevent their contamination by smoke.
- o **Smoke dampers** installed on the protected premises accept smoke fumes and direct them into smoke shafts. Such devices are equipped with electric magnet or electric actuators. The dampers are rated according to the fire-resistance limit which can vary up to 180 minutes at the smoke temperature of 600 °C.
- o **Fire-resisting dampers** are installed in exhaust ventilation and general ventilation systems to prevent the spread of fire hazards (fire and smoke fumes). Such units are equipped with an electric actuator or a thermal lock.
- o **Ventilation air ducts and shafts** are intended for transferring smoke fumes from the protected premises away from the building. Air ducts are made of non-combustible materials.

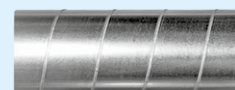
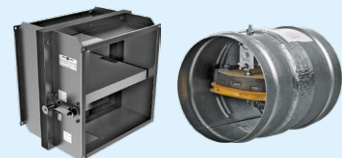
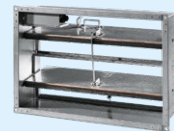

SAMPLE SCHEME AND OPERATION OF A SMOKE EXTRACTION SYSTEM IN A MULTI-STOREY RESIDENTIAL BUILDING WITH AN UNDERGROUND CAR PARK

SMOKE CONTROL SYSTEM SOLUTION

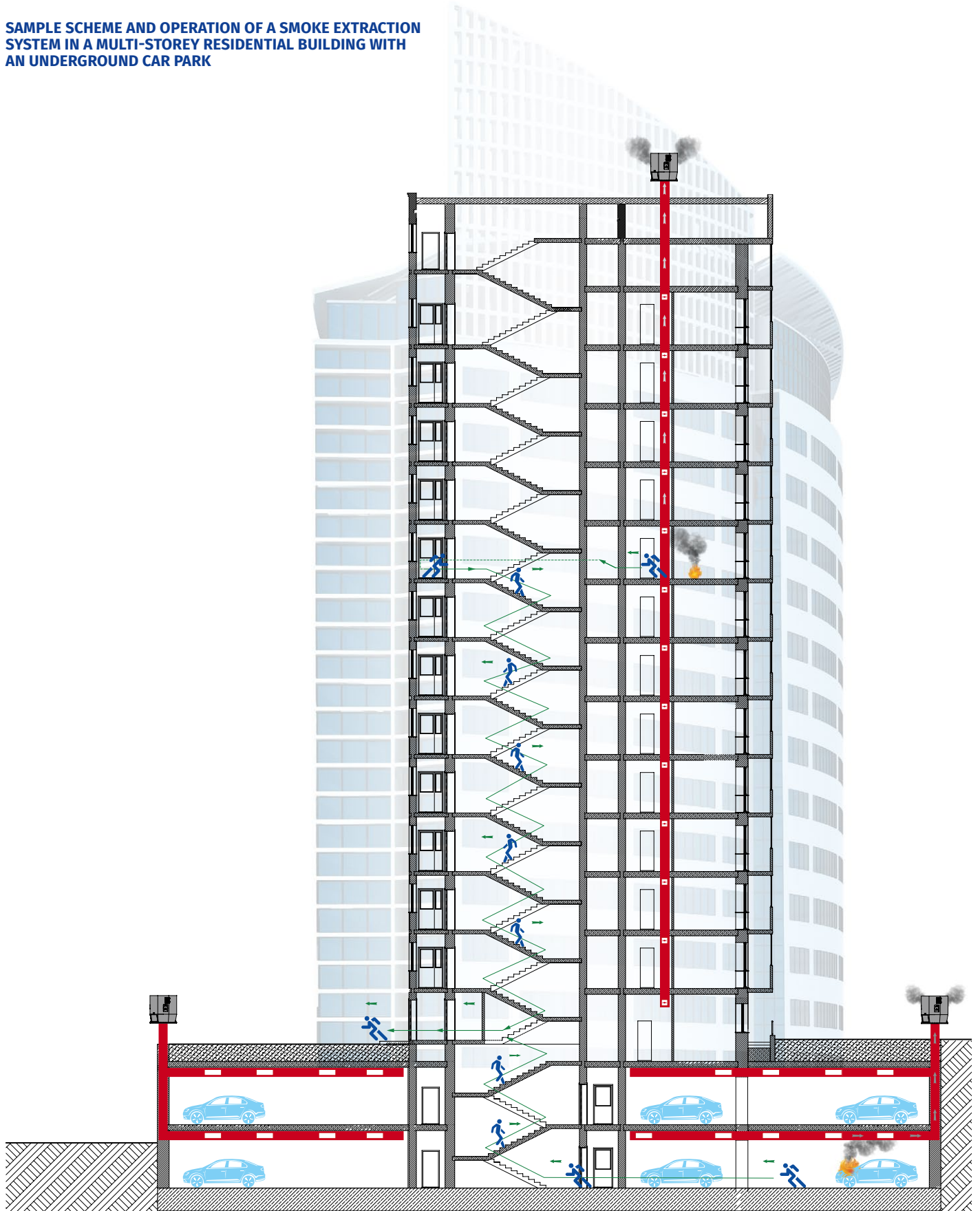

Typical smoke control system solution in case of a fire on the second floor:
Ventilation system: fire-resisting dampers **BSK** ③ and ④ block the floor 2 (closed), thus containing the fire and smoke at the ignition floor, fire-resisting dampers **BSK** ② and ⑥ remain open enabling pressurisation of the adjacent floors 1 and 3 by the supply ventilation system while fire-resisting dampers **BSK** ① and ⑤ in the exhaust ventilation branch remain closed.

Smoke control system: smoke extraction is handled by the **Tower-SH / Tower-SV** fan via the open **RSKM** ⑪ damper, the supply air is fed from the air pressurisation system via the open damper ⑧ while dampers ⑦, ⑨, ⑩ and ⑫ remain closed.

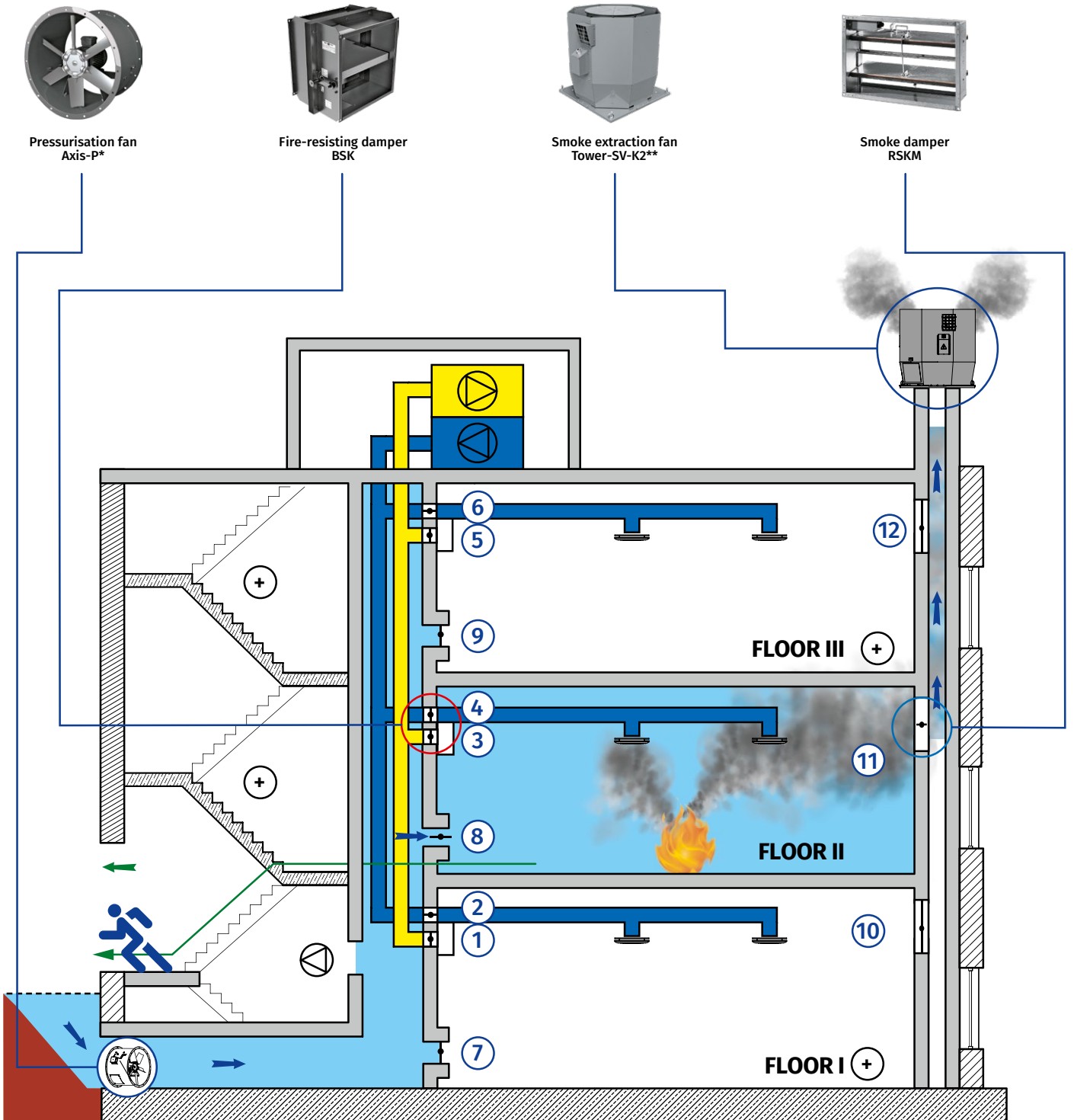

*Detailed information on fans is provided in the "Medium pressure axial fans and axial smoke extraction fans" catalogue.

**Detailed information on fans is provided in the "Centrifugal smoke extraction fans" catalogue.

RSKE / RSKM

Multi-purpose fire safety smoke dampers

Use

- The dampers are intended for integration into smoke control systems of buildings and structures of various purpose and designed for extraction of combustion products from the spaces of floor corridors, hallways, air locks etc.
- The dampers can be used as smoke dampers in emergency smoke extraction ventilation systems in the event of a fire to support evacuation of people from the building at the initial phase of the fire occurring in any of the building spaces.
- The RSKE/RSKM multi-purpose fire safety smoke dampers are rated to resist fire for 180 minutes (E 180) at the temperature of 600 °C.



Fire resistance rating:
600 °C within 180 min.



Normally closed single louvre fire safety dampers RSKE



Normally closed multiple-louvre fire safety dampers RSKM

Design

- The damper casing is made of galvanised steel 1.5 mm thick.
- The dampers are available in the wall-mounted or duct-mounted variant which have either one or two attachment flanges.

Control and modifications

- The units are available in two control options (with an electric magnet and with an electric actuator in different configurations):

THE DAMPER WITH AN ELECTRIC MAGNET (220 OR 24 V)

- The damper opens via a spring when the electric magnet is energized. When the damper reaches the end position, a limit switch opens the circuit disconnecting the electric magnet from the power mains. The electric magnet must not remain energized for more than 2 seconds. The damper is reset to the safety (closed) position manually by means of a handle. The damper equipped with an electric magnet has a special button for testing the unit performance.

THE DAMPER WITH A 230 OR 24 V ELECTRIC ACTUATOR AND A RETURN SPRING

- The flaps are automatically set to the normal (closed) position when applying voltage to the electric actuator. On a fire alarm signal the electric actuator is de-energized causing its return spring to set the damper to an open position. The electric actuator is equipped with a contact group to signal its end positions. The damper can also be controlled manually and fixed in any position. The unit can be unlocked either manually using a hex wrench or automatically upon power-up.

THE DAMPER WITH A 230 OR 24 V ELECTRIC ACTUATOR AND TWO-WIRE CONTROL

- The damper flap is set from the "Open" to the "Closed" position by an external command sending the voltage phase from one actuator contact to the other. The electric actuator is equipped with a contact group to signal its end positions. The damper can be controlled manually by means of a hex key.

Note. The RSKM dampers with a height of 300 and 350 mm have one louvre. The main difference between the RSKM and the RSKE dampers with a similar height of 300 and 350 mm is that the method of fastening the flap, which ensures a smaller overhang of the flap beyond the RSKM damper.

Mounting

- The dampers are not intended for installation in air ducts and ducts of spaces with fire and explosion hazard categories A and in local exhaust systems designed for extraction of flammable and explosive mixtures as well as in systems containing environments more aggressive to plain carbon steels than air or those containing sticky and fibrous materials.
- Fire safety dampers are only intended for installation in systems subjected to regular cleaning to prevent formation of flammable deposits.
- The damper must be installed into the building envelope structure in accordance with the applicable standards and regulations. The seal fire resistance must be at least equal to that of the building envelope. When preparing for installation the damper casing should be fitted with wooden spreader bars to prevent deformation, torsional twisting or geometry perturbation of the casing which may result in louvre jamming and, eventually, loss of the damper functionality.

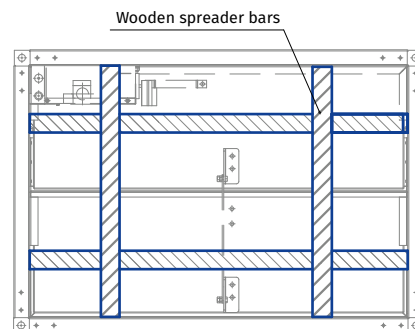

- Upon completion of the damper brickwork envelope in the smoke shaft, fire division wall or flooring and complete cure (setting) of the sealing, remove the wooden spreader bars and check the louvre for free and frictionless opening.
- Ground the damper, connect the electromagnet or electric actuator (depending on the modification) to the automatic fire-fighting system and test the damper actuation.

Designation key

RSKE/RSKM 30 x 30 / 1 PKP24 / O

Damper series:

RSKE: single-louvre

RSKM: multi-louvre

Damper flow area width [cm]:

30; 35; 40; 45; 50; 55; 60; 65; 70; 75; 80; 85; 90; 95; 100

Damper flow area height [cm]:

30; 35; 40; 45; 50; 55; 60; 65; 70; 75; 80; 85; 90; 95; 100

Number of flanges:

1: one

2: two

Actuator type:

EM220/24: 220/24 V electric magnet

PKP24: 24 V ZERN electric actuator with a return spring

PKP230: 230 V ZERN electric actuator with a return spring

PV24: 24 V BELIMO open/close electric actuator

PV230: 230 V BELIMO open/close electric actuator

PVP24: 24 V BELIMO electric actuator with a return spring

PVP230: 230 V BELIMO electric actuator with a return spring

PS24: 24 V SIEMENS open/close electric actuator

PS230: 230 V SIEMENS open/close electric actuator

PSP24: 24 V SIEMENS electric actuator with a return spring

PSP230: 230 V SIEMENS actuator with a return spring

Actuator location:

O: outside (except for EM220/24 electric magnet)

I: inside

Installation recommendation for the RSKM damper with an internally connected actuator

IN VERTICAL BUILDING STRUCTURES

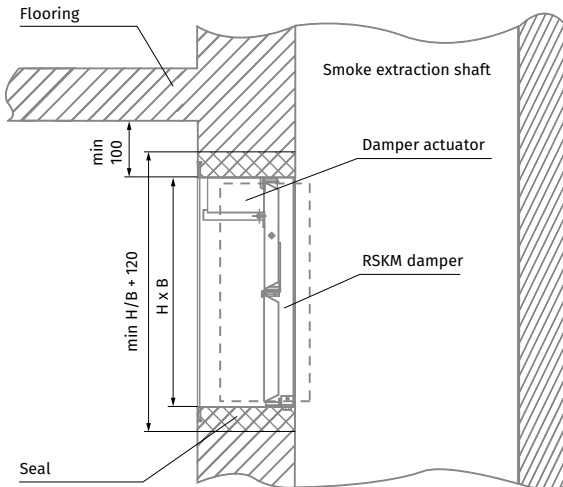

IN HORIZONTAL BUILDING STRUCTURES

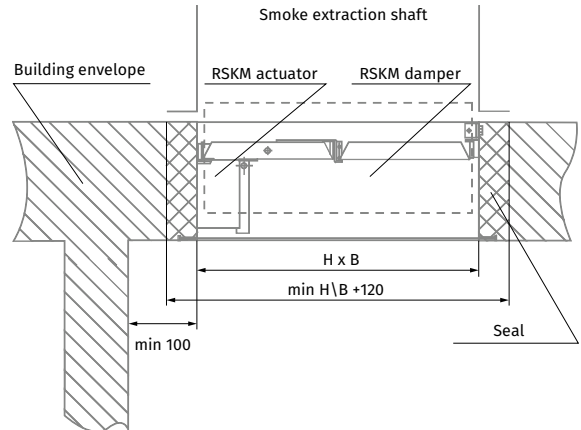

DUCT MODIFICATION WITH AN AIR DUCT

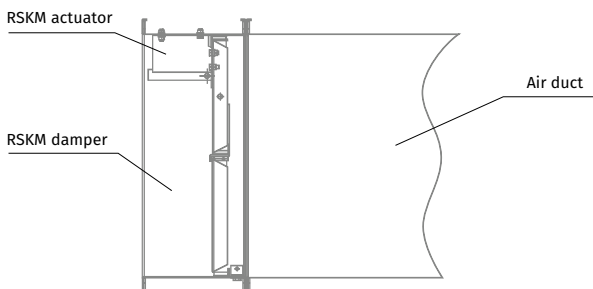

Installation recommendation for the RSKM damper with an externally located actuator

IN VERTICAL BUILDING STRUCTURES

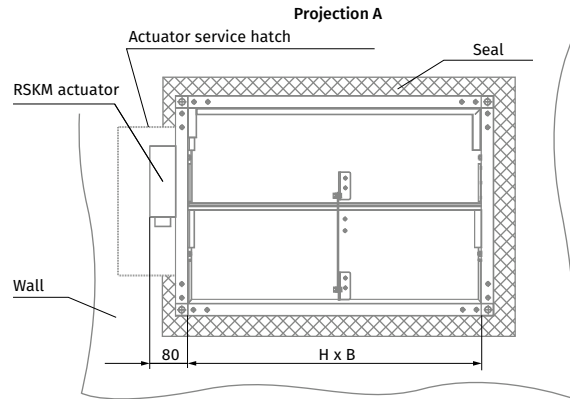
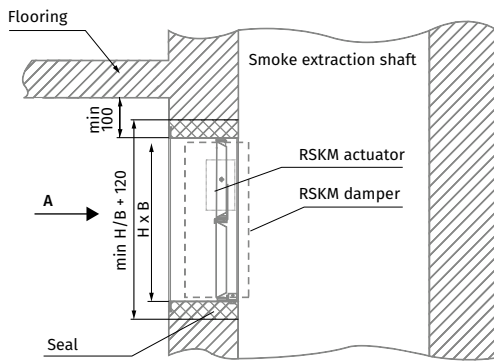

DUCT MODIFICATION WITH AN AIR DUCT

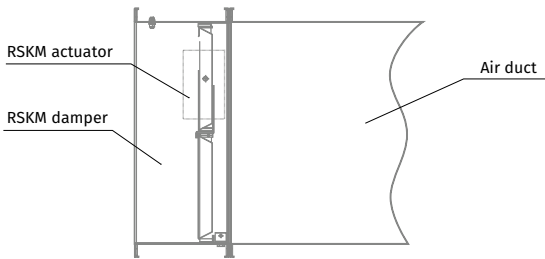

IN HORIZONTAL BUILDING STRUCTURES

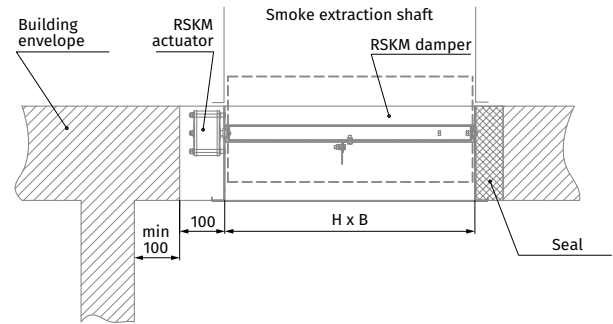

Installation recommendation for the RSKE damper with an internally connected actuator

IN VERTICAL BUILDING STRUCTURES

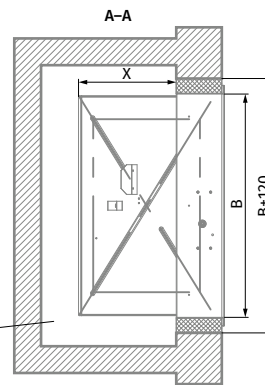
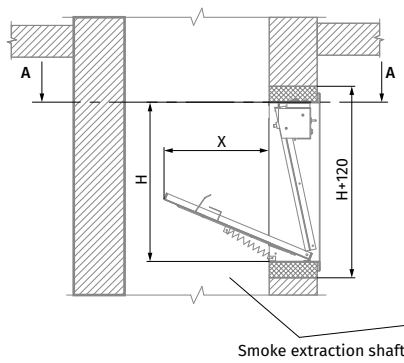

DUCT MODIFICATION WITH AN AIR DUCT

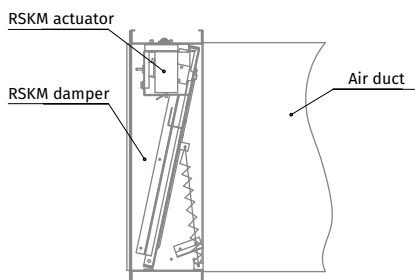

IN HORIZONTAL BUILDING STRUCTURES

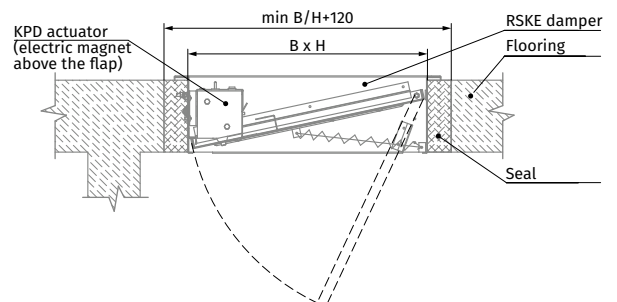

Possible RSKM damper variants

THE RSKM DAMPER WITH AN INTERNALLY INSTALLED ELECTROMAGNET (220/24 V), SINGLE OR DOUBLE FLANGE

- The single flange variant is intended for wall or ceiling mounting irrespective of the dimensional orientation. Upon the test or emergency damper actuation, the louvres can only be manually reset to the initial position.
- The double flange variant is intended for duct installation irrespective of the dimensional orientation. Upon the test or emergency damper actuation the louvres can only be manually reset to the initial position.

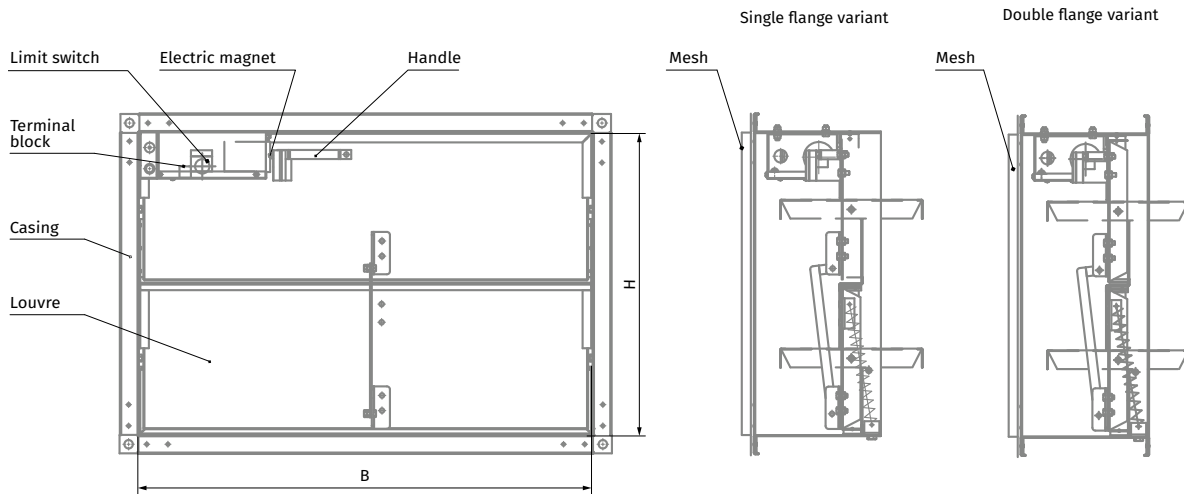

FLOW AREA OF THE RSKM SMOKE EXHAUST DAMPER WITH AN ELECTROMAGNET [m²]

B/H [mm]	300	350	400	450	500	550	600	650	700	750	800	850	900	950	1000
300	0.06														
350	0.08	0.10													
400	0.09	0.11	0.12												
450	0.10	0.13	0.14	0.16											
500	0.12	0.14	0.15	0.18	0.20										
550	0.13	0.16	0.17	0.20	0.23	0.25									
600	0.15	0.18	0.19	0.22	0.25	0.28	0.31								
650	0.16	0.19	0.20	0.24	0.27	0.30	0.33	0.37							
700	0.17	0.21	0.22	0.26	0.29	0.33	0.36	0.40	0.43						
750	0.19	0.22	0.24	0.28	0.31	0.35	0.39	0.43	0.46	0.48					
800	0.20	0.24	0.26	0.30	0.34	0.38	0.42	0.46	0.50	0.51	0.55				
850	0.21	0.26	0.27	0.31	0.36	0.40	0.44	0.48	0.53	0.54	0.59	0.63			
900	0.23	0.27	0.29	0.33	0.38	0.42	0.47	0.51	0.56	0.58	0.62	0.67	0.71		
950	0.24	0.29	0.31	0.35	0.40	0.45	0.50	0.54	0.59	0.61	0.66	0.71	0.75	0.80	
1000	0.25	0.30	0.32	0.37	0.42	0.47	0.52	0.57	0.62	0.64	0.69	0.74	0.79	0.84	0.89

Note: Select the damper of the required cross-section BxH according to the completed table cells. Since the damper can be installed in any spatial position, a change of the height and width (B and H values) orientation may enable selection of a damper with a cross-section beyond the completed cell range.

For example, a 700x500 mm damper can be ordered as 500x700 mm.

**THE RSKM DAMPER WITH AN ELECTRIC ACTUATOR (230 OR 24 V)
INSTALLED INSIDE THE DAMPER, SINGLE OR DOUBLE FLANGE**

- The single flange variant is intended for wall or ceiling mounting irrespective of the dimensional orientation.
- The double flange variant is intended for duct installation irrespective of the dimensional orientation. The louvres of dampers equipped with a

two-position electric actuator are set to the "open" or "closed" position by an external actuating signal. After a test or emergency actuation the louvres of dampers equipped with an electric actuator with a return spring can return to the initial position automatically upon feeding the supply voltage.

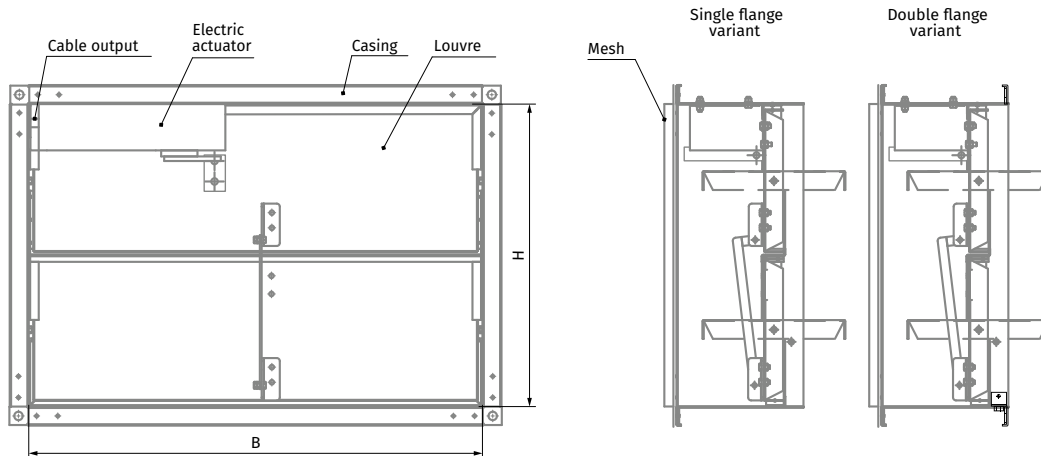

FLOW AREA OF THE RSKM SMOKE EXHAUST DAMPER WITH AN ELECTRIC ACTUATOR INSTALLED INSIDE THE DAMPER [m²]

B/H [mm]	300	350	400	450	500	550	600	650	700	750	800	850	900	950	1000
300	0.06														
350	0.08	0.10													
400	0.09	0.11	0.12												
450	0.10	0.13	0.14	0.16											
500	0.12	0.14	0.15	0.18	0.20										
550	0.13	0.16	0.17	0.20	0.23	0.25									
600	0.15	0.18	0.19	0.22	0.25	0.28	0.31								
650	0.16	0.19	0.20	0.24	0.27	0.30	0.33	0.37							
700	0.17	0.21	0.22	0.26	0.29	0.33	0.36	0.40	0.43						
750	0.19	0.22	0.24	0.28	0.31	0.35	0.39	0.43	0.46	0.48					
800	0.20	0.24	0.26	0.30	0.34	0.38	0.42	0.46	0.50	0.51	0.55				
850	0.21	0.26	0.27	0.31	0.36	0.40	0.44	0.48	0.53	0.54	0.59	0.63			
900	0.23	0.27	0.29	0.33	0.38	0.42	0.47	0.51	0.56	0.58	0.62	0.67	0.71		
950	0.24	0.29	0.31	0.35	0.40	0.45	0.50	0.54	0.59	0.61	0.66	0.71	0.75	0.80	
1000	0.25	0.30	0.32	0.37	0.42	0.47	0.52	0.57	0.62	0.64	0.69	0.74	0.79	0.84	0.89

Note: Select the damper of the required cross-section BxH according to the completed table cells. Since the damper can be installed in any spatial position, a change of the height and width (B and H values) orientation may enable selection of a damper with a cross-section beyond the completed cell range.

For example, a 700x500 mm damper can be ordered as 500x700 mm.

THE RSKM DAMPER WITH AN ELECTRIC ACTUATOR (230 OR 24 V) INSTALLED OUTSIDE THE DAMPER, SINGLE OR DOUBLE FLANGE

- o The single flange variant is intended for wall or ceiling mounting irrespective of the dimensional orientation.
- o The double flange variant is intended for duct installation irrespective of the dimensional orientation. The louvres of dampers equipped with a

two-position electric actuator are set to the "open" or "closed" position by an external actuating signal. After a test or emergency actuation the louvres of dampers equipped with an electric actuator with a return spring can return to the initial position automatically upon feeding the supply voltage.

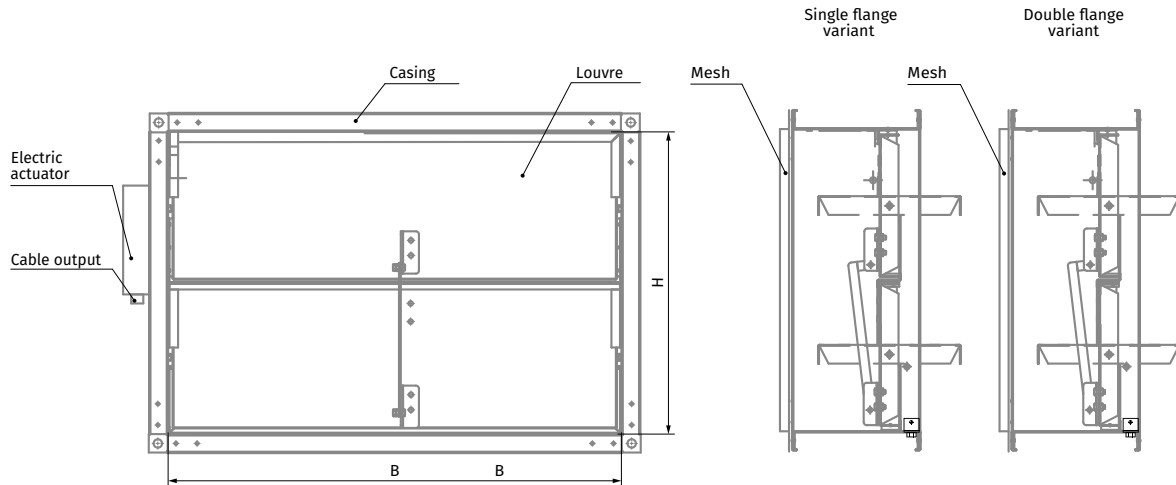

FLOW AREA OF THE RSKM SMOKE EXHAUST DAMPER WITH AN ELECTRIC ACTUATOR INSTALLED INSIDE THE DAMPER [M²]

B/H [mm]	300	350	400	450	500	550	600	650	700	750	800	850	900	950	1000
300	0.07														
350	0.09	0.11													
400	0.10	0.12	0.13												
450	0.11	0.14	0.15	0.17											
500	0.13	0.15	0.16	0.19	0.21										
550	0.14	0.17	0.18	0.21	0.24	0.26									
600	0.16	0.18	0.20	0.23	0.26	0.29	0.32								
650	0.17	0.20	0.21	0.25	0.28	0.31	0.34	0.38							
700	0.18	0.22	0.23	0.27	0.30	0.34	0.37	0.41	0.44						
750	0.20	0.23	0.25	0.29	0.32	0.36	0.40	0.44	0.47	0.49					
800	0.21	0.25	0.27	0.31	0.35	0.39	0.43	0.47	0.51	0.52	0.56				
850	0.22	0.27	0.28	0.32	0.37	0.41	0.45	0.49	0.54	0.55	0.60	0.64			
900	0.24	0.28	0.30	0.34	0.39	0.43	0.48	0.52	0.57	0.59	0.63	0.68	0.72		
950	0.25	0.30	0.32	0.36	0.41	0.46	0.51	0.55	0.60	0.62	0.67	0.72	0.76	0.81	
1000	0.26	0.31	0.33	0.38	0.43	0.48	0.53	0.58	0.63	0.65	0.70	0.75	0.80	0.85	0.90

Note: Select the damper of the required cross-section BxH according to the completed table cells. Since the damper can be installed in any spatial position, a change of the height and width (B and H values) orientation may enable selection of a damper with a cross-section beyond the completed cell range.

For example, a 700x500 mm damper can be ordered as 500x700 mm.

Possible RSKE damper variants

THE RSKE DAMPER WITH AN INTERNALLY INSTALLED ELECTROMAGNET (220/24 V), SINGLE OR DOUBLE FLANGE

- The single flange variant is intended for wall or ceiling installation. The damper must be installed according to the installation guidelines for the RSKE damper with an internal actuator (see page 14). Upon the test or emergency damper actuation, the louvres can only be manually reset to initial position.
- The double flange variant is intended for duct installation. Upon the test or emergency damper actuation the louvres can only be manually reset to the initial position.

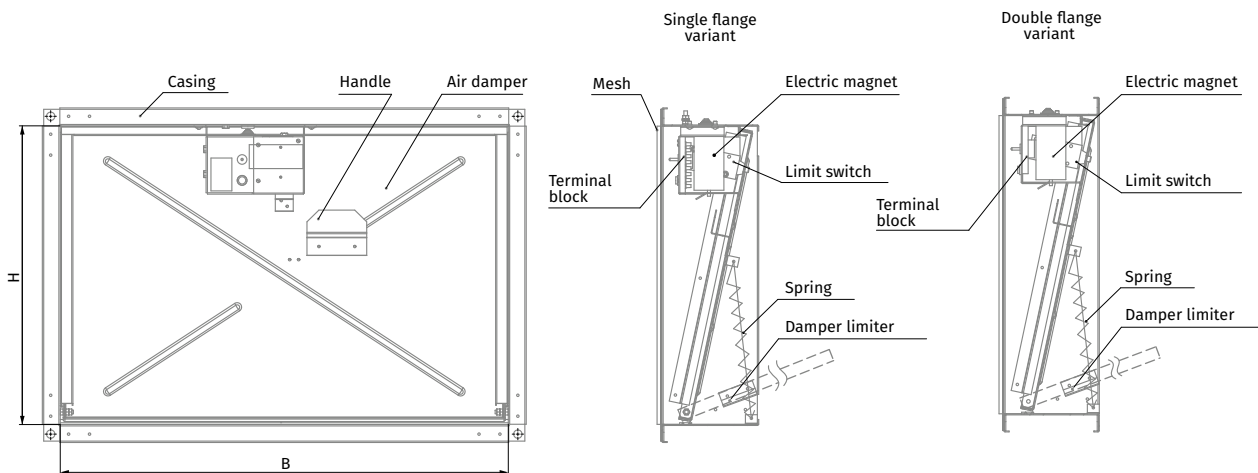

FLOW AREA OF THE RSKE SMOKE EXHAUST DAMPER WITH AN ELECTROMAGNET [m²]

B/H [mm]	300	350	400	450	500	550	600	650	700	750	800	850	900	950	1000
300	0.06														
350	0.08	0.10													
400	0.09	0.11	0.12												
450	0.10	0.13	0.14	0.16											
500	0.12	0.14	0.15	0.18	0.20										
550	0.13	0.16	0.17	0.20	0.23	0.25									
600	0.15	0.18	0.19	0.22	0.25	0.28	0.31								
650	0.16	0.19	0.20	0.24	0.27	0.30	0.33	0.37							
700	0.17	0.21	0.22	0.26	0.29	0.33	0.36	0.40	0.43						
750	0.19	0.22	0.24	0.28	0.31	0.35	0.39	0.43	0.46	0.48					
800	0.20	0.24	0.26	0.30	0.34	0.38	0.42	0.46	0.50	0.51	0.55				
850	0.21	0.26	0.27	0.31	0.36	0.40	0.44	0.48	0.53	0.54	0.59	0.63			
900	0.23	0.27	0.29	0.33	0.38	0.42	0.47	0.51	0.56	0.58	0.62	0.67	0.71		
950	0.24	0.29	0.31	0.35	0.40	0.45	0.50	0.54	0.59	0.61	0.66	0.71	0.75	0.80	
1000	0.25	0.30	0.32	0.37	0.42	0.47	0.52	0.57	0.62	0.64	0.69	0.74	0.79	0.84	0.89

Note: Select the damper of the required cross-section BxH according to the completed table cells.

THE RSKE DAMPER WITH AN ELECTRIC ACTUATOR (230 OR 24 V) INSTALLED INSIDE THE DAMPER, SINGLE OR DOUBLE FLANGE

- o The single flange variant is intended for wall or ceiling mounting irrespective of the dimensional orientation.
- o The double flange variant is intended for duct installation irrespective of the dimensional orientation. The louvres of dampers equipped with a

two-position electric actuator are set to the "open" or "closed" position by an external actuating signal. After a test or emergency actuation the louvres of dampers equipped with an electric actuator with a return spring can return to the initial position automatically upon feeding the supply voltage.

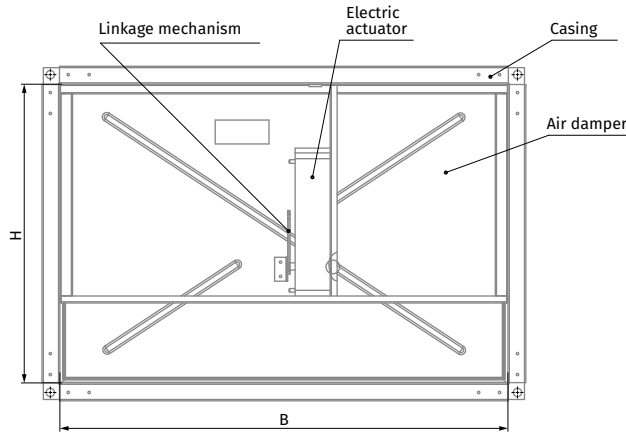

Single flange variant

Double flange variant

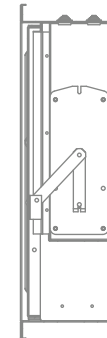
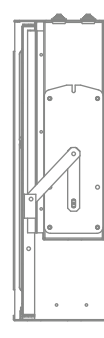

FLOW AREA OF THE RSKE SMOKE EXHAUST DAMPER WITH AN ELECTRIC ACTUATOR INSTALLED INSIDE THE DAMPER [m²]

B/H [mm]	300	350	400	450	500	550	600	650	700	750	800	850	900	950	1000
300	0.06														
350	0.08	0.10													
400	0.09	0.11	0.12												
450	0.10	0.13	0.14	0.16											
500	0.12	0.14	0.15	0.18	0.20										
550	0.13	0.16	0.17	0.20	0.23	0.25									
600	0.15	0.18	0.19	0.22	0.25	0.28	0.31								
650	0.16	0.19	0.20	0.24	0.27	0.30	0.33	0.37							
700	0.17	0.21	0.22	0.26	0.29	0.33	0.36	0.40	0.43						
750	0.19	0.22	0.24	0.28	0.31	0.35	0.39	0.43	0.46	0.48					
800	0.20	0.24	0.26	0.30	0.34	0.38	0.42	0.46	0.50	0.51	0.55				
850	0.21	0.26	0.27	0.31	0.36	0.40	0.44	0.48	0.53	0.54	0.59	0.63			
900	0.23	0.27	0.29	0.33	0.38	0.42	0.47	0.51	0.56	0.58	0.62	0.67	0.71		
950	0.24	0.29	0.31	0.35	0.40	0.45	0.50	0.54	0.59	0.61	0.66	0.71	0.75	0.80	
1000	0.25	0.30	0.32	0.37	0.42	0.47	0.52	0.57	0.62	0.64	0.69	0.74	0.79	0.84	0.89

Note: Select the damper of the required cross-section BxH according to the completed table cells. Since the damper can be installed in any spatial position, a change of the height and width (B and H values) orientation may enable selection of a damper with a cross-section beyond the completed cell range.

For example, a 700x500 mm damper can be ordered as 500x700 mm.

THE RSKE DAMPER WITH AN ELECTRIC ACTUATOR (230 OR 24 V) INSTALLED OUTSIDE THE DAMPER, SINGLE OR DOUBLE FLANGE:

- The single flange variant is intended for wall or ceiling mounting irrespective of the dimensional orientation.
- The double flange variant is intended for duct installation irrespective of the dimensional orientation. The louvres of dampers equipped with a two-position electric actuator are set to the "open" or "closed" position

tion by an external actuating signal. After a test or emergency actuation the louvres of dampers equipped with an electric actuator with a return spring can return to the initial position automatically upon feeding the supply voltage.

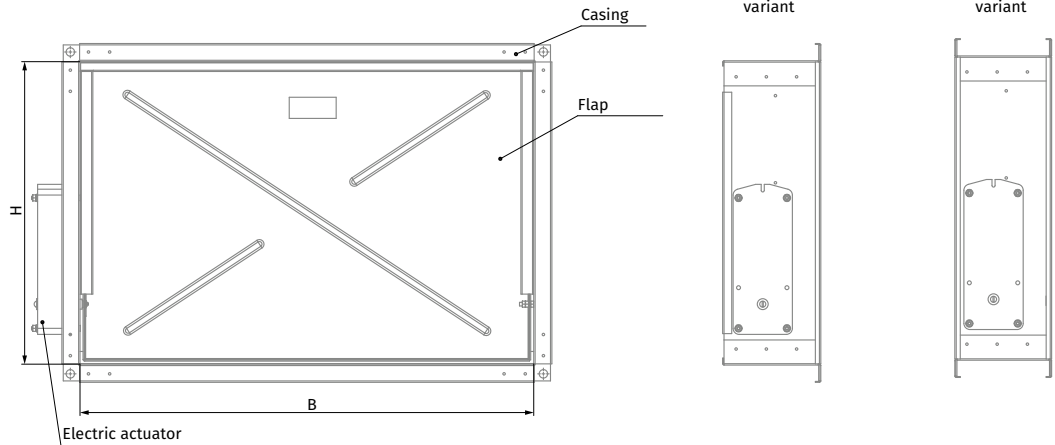

FLOW AREA OF THE RSKE SMOKE EXHAUST DAMPER WITH AN ELECTRIC ACTUATOR INSTALLED OUTSIDE THE DAMPER [m²]

B/H [mm]	300	350	400	450	500	550	600	650	700	750	800	850	900	950	1000
300	0.07														
350	0.09	0.11													
400	0.10	0.12	0.13												
450	0.11	0.14	0.15	0.17											
500	0.13	0.15	0.16	0.19	0.21										
550	0.14	0.17	0.18	0.21	0.24	0.26									
600	0.16	0.18	0.20	0.23	0.26	0.29	0.32								
650	0.17	0.20	0.21	0.25	0.28	0.31	0.34	0.38							
700	0.18	0.22	0.23	0.27	0.30	0.34	0.37	0.41	0.44						
750	0.20	0.23	0.25	0.29	0.32	0.36	0.40	0.44	0.47	0.49					
800	0.21	0.25	0.27	0.31	0.35	0.39	0.43	0.47	0.51	0.52	0.56				
850	0.22	0.27	0.28	0.32	0.37	0.41	0.45	0.49	0.54	0.55	0.60	0.64			
900	0.24	0.28	0.30	0.34	0.39	0.43	0.48	0.52	0.57	0.59	0.63	0.68	0.72		
950	0.25	0.30	0.32	0.36	0.41	0.46	0.51	0.55	0.60	0.62	0.67	0.72	0.76	0.81	
1000	0.26	0.31	0.33	0.38	0.43	0.48	0.53	0.58	0.63	0.65	0.70	0.75	0.80	0.85	0.90

Note: Select the damper of the required cross-section BxH according to the completed table cells. Since the damper can be installed in any spatial position, a change of the height and width (B and H values) orientation may enable selection of a damper with a cross-section beyond the completed cell range.

For example, a 700x500 mm damper can be ordered as 500x700 mm.

Technical data

ELECTROMAGNET

Parameters	Parameter value
Rated voltage [V]	220/24
Rated current at the ambient temperature of 25±10 °C [A]	0.6/5.5
Armature stroke [mm]	10±1
Armature release time [seconds]	2
Tractive force [N]	45
Maximum active power consumption at 220 V [W]	600
Maximum total power consumption at 220 V [W]	1200
Maximum total power consumption at 24 V [W]	60

BELIMO ELECTRIC ACTUATORS WITH A RETURN SPRING

Parameters	Basic models		Models with increased torque	
Rated voltage [V]	AC/DC 24	AC 230	AC/DC 24	AC 230
Rated voltage range [V]	AC 19.2...28.8 DC 21.6...28.8	AC 198...264	AC 19.2...28.8 DC 21.6...28.8	AC 198...264
Rated voltage frequency AC [Hz]	50/60		50/60	
Power consumption in rest position [W]	1.4	2.0	2	3
Power consumption in operation [W]	4.0	4.5	7	8.5
Maximum design capacity [VA]	6	9.0	10	11
Motor torque [Nm]	9		18	
Spring torque [Nm]	7		12	
Protection class	III	II	III	II
Ingress protection rating	IP54	IP54	IP54	IP54
Auxiliary switches	2 pcs., single-pole, reversible, 1 mA...3(0.5)A, AC 250 V		2 pcs., single-pole, reversible, 1 mA...6(3)A, AC 250 V	
Electric motor connection cable			1 m, 2 x 0.75 mm ² (halogen-free)	
Auxiliary switch connection cable			1 m, 6 x 0.75 mm ² (halogen-free)	
Running time spring	20 seconds at -10...+55 °C < 60 seconds at -30...-10 °C		16 seconds at +20 °C	
Running time motor	< 60 s/90°		< 120 s/90°	
Service life			Min. 60 000 emergency positions	
Technical maintenance			Not required	

BELIMO TWO-POSITION ELECTRIC ACTUATORS

Parameters	Basic models		Models with increased torque	
Rated voltage [V]	AC/DC 24	AC 230	AC/DC 24	AC 230
Rated voltage range [V]	AC 19.2...28.8 DC 21.6...28.8	AC 198...264	AC 19.2...28.8 DC 21.6...28.8	AC 198...264
Rated voltage frequency AC [Hz]	50/60		50/60	
Power consumption in rest position [W]	<0.5	<1	0.5	0.5
Power consumption in operation [W]	7,5	5	12	8
Maximum design capacity [VA]	9	12	18	15
Motor torque [Nm]	15		40	
Spring torque [Nm]	20		50	
Protection class	III	II	III	II
Ingress protection rating	IP54	IP54	IP54	IP54
Auxiliary switches			2 pcs., single-pole, reversible, 1 mA...3(0.5)A, AC 250 B	
Electric motor connection cable			1 m, 3 x 0.75 mm ² (halogen-free)	
Auxiliary switch connection cable			1 m, 6 x 0.75 mm ² (halogen-free)	
Running time	< 30 s/90°		< 60 s/90°	
Service life			Min. 10 000 emergency positions	
Technical maintenance			Not required	

ZERN ELECTRIC ACTUATORS WITH A RETURN SPRING

Parameters	Basic models		Models with increased torque	
Rated voltage [V]	AC/DC 24	AC 100–240	AC/DC 24	AC 100–240
Rated voltage range [V]	AC/DC 19.2...28.8	AC 85...265	AC/DC 19.2...28.8	AC 85...265
Rated voltage frequency AC [Hz]	50/60		50/60	
Power consumption in rest position [W]	3		3	
Power consumption in operation [W]	5		5	
Motor torque [Nm]	5		8	
Spring torque [Nm]	5		8	
Protection class	III	II	III	II
Ingress protection rating	IP54	IP54	IP54	IP54
Auxiliary switches	2 pcs., single-pole, reversible, 1 mA...3(0.5)A, AC 220 B 1 mA...3(0.5)A, AC 220 V			
Electric motor connection cable	1 m, 2 x 0.5 mm ² (halogen-free)			
Auxiliary switch connection cable	1 m, 6 x 0.5 mm ² (halogen-free)			
Running time spring	<20 seconds < 60 seconds at -30...-10 °C		<25 seconds < 60 seconds at -30...-10 °C	
Running time motor	< 70 s/95°		< 100 s/95°	

SIEMENS ELECTRIC ACTUATORS WITH A RETURN SPRING

Parameters	Basic models		Models with increased torque	
Rated voltage [V]	AC 24 / DC 24...48	AC 230	AC 24 / DC 24...48	AC 230
Rated voltage range [V]	AC/DC ±20 %	AC ±15 %	AC/DC ±20 %	AC ±15 %
Rated voltage frequency AC [Hz]	50/60		50/60	
Power consumption in rest position [W]	2	3.5	3	4
Power consumption in operation [W]	3.5	4.5	5	6
Maximum design capacity [VA]	5	7	7	8
Motor torque [Nm]	9		18	
Spring torque [Nm]	7		18	
Protection class	III	II	III	II
Ingress protection rating	IP54	IP54	IP54	IP54
Auxiliary switches	2 pcs., single-pole, reversible, 6(2)A, AC 24...250 V			
Electric motor connection cable	0.9 m, 2 x 0.75 mm ² (halogen-free)			
Auxiliary switch connection cable	0.9 m, 6 x 0.75 mm ² (halogen-free)			
Running time spring	15 seconds < 60 seconds at -30...-10 °C			
Running time motor	90 s/90°		90 s/90°	
Service life	10 000 emergency positions			
Technical maintenance	Not required			

Note: The table "Main technical specifications of Siemens two-position electric actuators" is in development. This information is available upon request.

Electrical connection diagrams of RSKE/RSKM dampers

RSKE/RSKM DAMPER EQUIPPED WITH AN ELECTROMAGNET

- SQ1:** end switch
- YA1:** electromagnet
- SB1:** damper louvre opening button
- PK:** contact of automatic fire suppression block
- SA1:** power supply circuit disconnection switch of electromagnetic latch
- X1:** terminal block

- 1:** supply voltage phase
- 2:** contact of automatic fire suppression block
- 3:** supply voltage neutral
- 4, 5:** command circuit control
- 6, 7:** louvre position control
- 8:** grounding bus

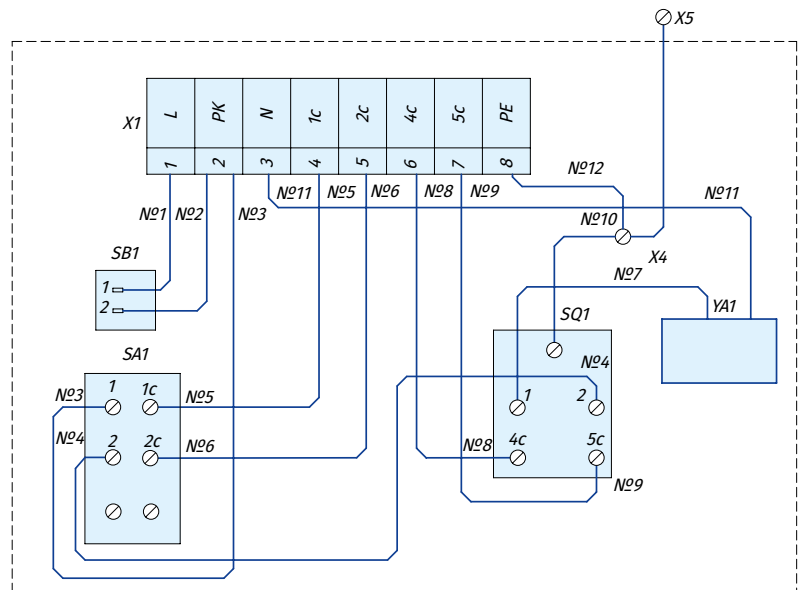

RSKE/RSKM DAMPER EQUIPPED WITH AN ELECTRIC ACTUATOR

Electric actuator with a return spring

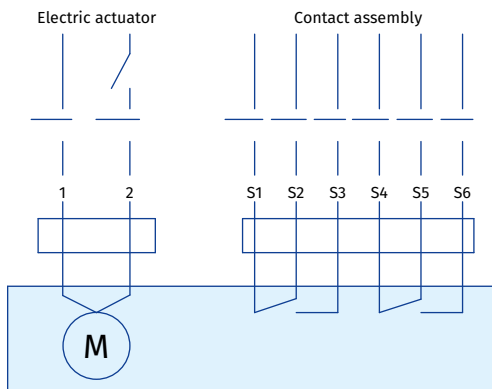

- 1:** "Neutral" contact of supply voltage
- 2:** "Line" contact of supply voltage – closing the damper louvres
- S1...S6:** fixed microswitch contacts for signalling end positions

Two-position electric actuator

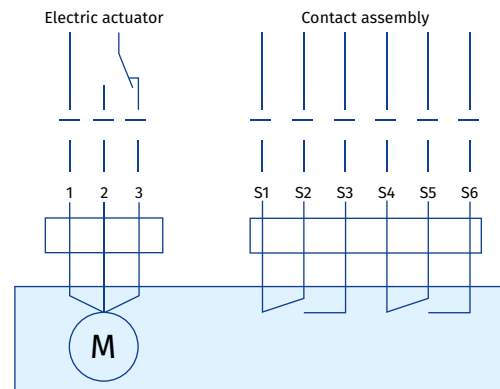

- 1:** "Neutral" contact of supply voltage
- 2, 3:** "Line" contact of supply voltage damper louvre closing or opening
- S1...S6:** fixed microswitch contacts for signalling end positions

Overall and connecting dimensions of RSKM multi-louvre dampers

Standard damper size [cm]	Minimum flow area [m ²]	Dimensions [mm]							Maximum RSKM weight [kg]
		H	H1	H2	B	B1	B2	L	
40x40	0.12	400	420	440	400	420	440	298	9.5
50x50	0.2	500	520	540	500	520	540	297	12.1
60x60	0.31	600	630	660	600	630	660	348	17
70x70	0.43	700	730	760	700	730	760	398	20.3
80x80	0.55	800	830	860	800	830	860	448	24.1
90x90	0.71	900	930	960	900	930	960	498	27.4
100x100	0.9	1000	1030	1060	1000	1030	1060	548	31.7

- o The **RSKM** damper with an internally installed electromagnet (220/24 V), single or double flange.

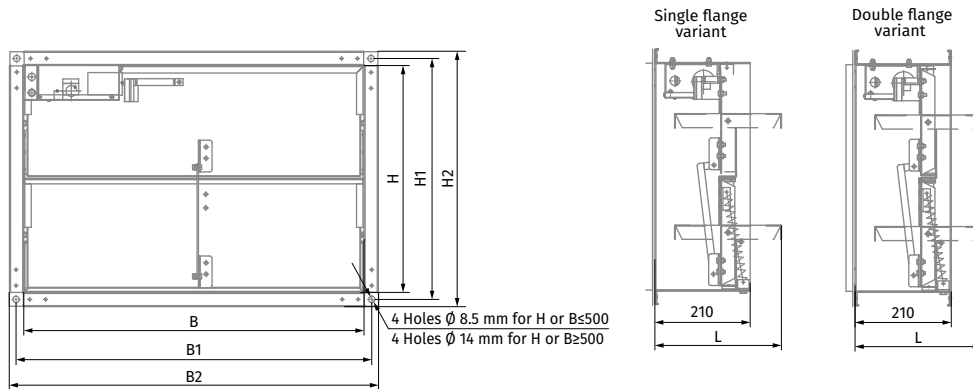

- o The **RSKM** damper with an electric actuator (230 or 24 V) installed inside the damper, single or double flange.

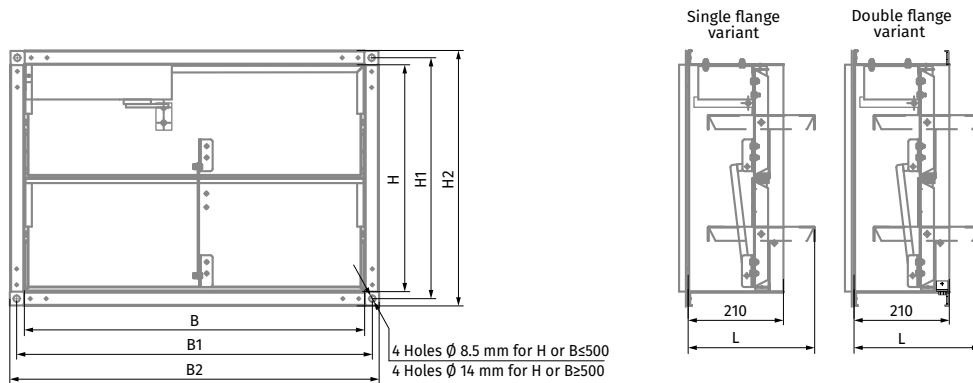

- o The **RSKM** damper with an electric actuator (230 or 24 V) installed outside the damper, single or double flange.

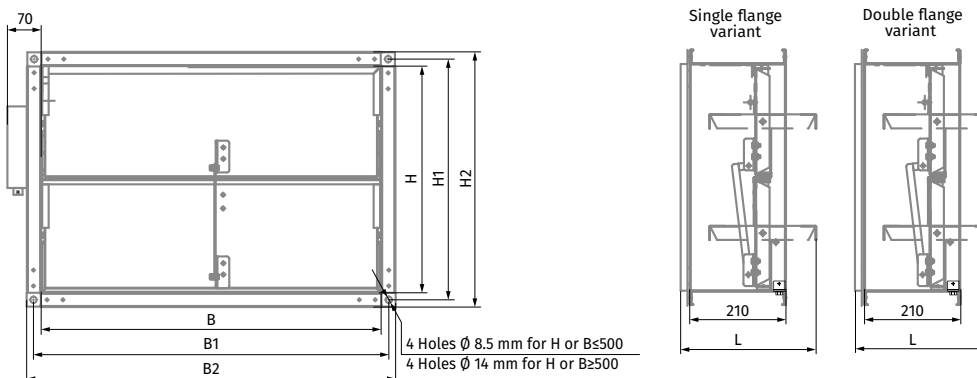

Overall and connecting dimensions of the RSKE single-louvre damper

Standard damper size [cm]	Minimum flow area [m ²]	Dimensions [mm]							Maximum RSKE weight [kg]
		H	H1	H2	B	B1	B2	L	
40x40	0.12	400	430	460	400	430	460	470	8.2
50x50	0.2	500	530	560	500	530	560	570	10.6
60x60	0.31	600	630	660	600	630	660	670	13.2
70x70	0.43	700	730	760	700	730	760	770	16
80x80	0.55	800	830	860	800	830	860	870	19
90x90	0.71	900	930	960	900	930	960	970	22.2
100 x100	0.9	1000	1030	1060	1000	1030	1060	1070	25.6

- The **RSKE** damper with an internally installed electromagnet (220/24 V), single or double flange.

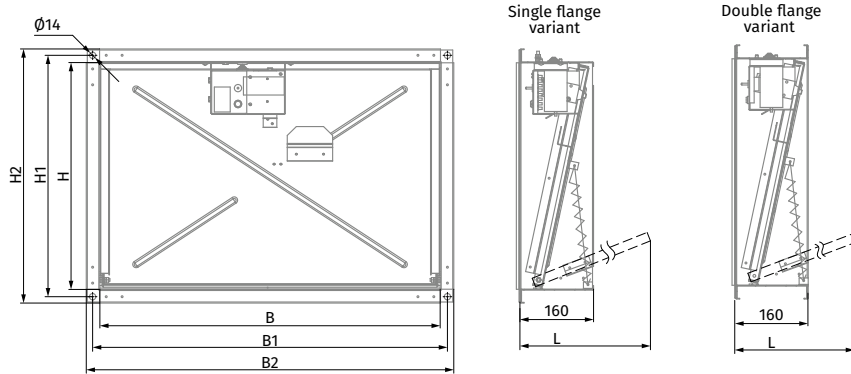

- The **RSKE** damper with an electric actuator (230 or 24 V) installed outside the damper, single or double flange.

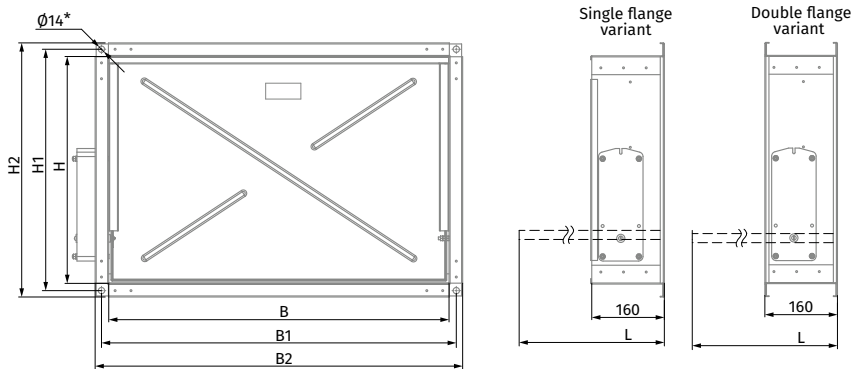

- The **RSKE** damper with an electric actuator (230 or 24 V) installed inside the damper, single or double flange.

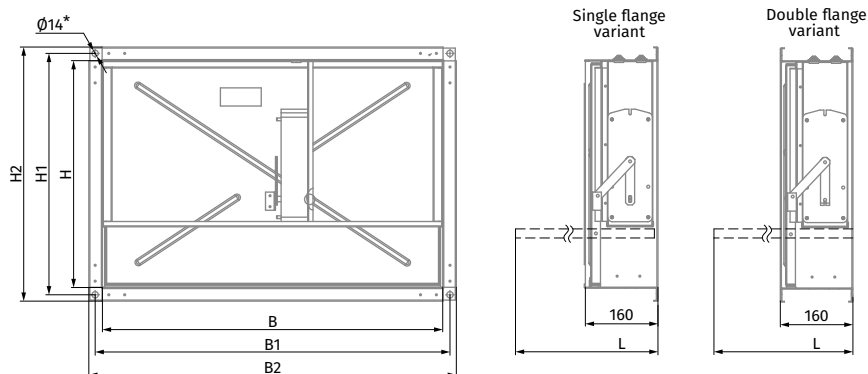

BSK1

Fire-resisting dampers

Use

- The fire-resisting dampers are intended for automatic closing of process openings and air duct penetrations in intermediate floors, walls and partitions, as well as closing of openings in supply and exhaust ducts of smoke ventilation systems.
- The dampers of this particular design are not suitable for installation in air ducts and ducts of premises with rated explosion and fire safety category A and B and in flammable and explosive mixture intakes.
- The **BSK1** fire-resisting duct dampers are capable of resisting fire for at least 60 minutes (EI 60) at the temperature of 600 °C.

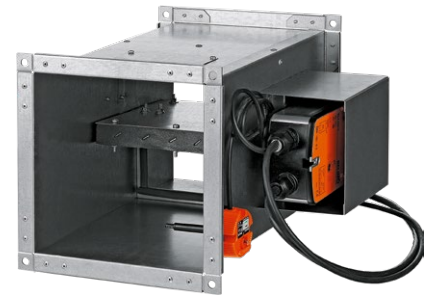

**BSK1...PKP
BSK1...PVP
BSK1...PSP**
normally open fire-resisting duct damper with electric drive mechanism.



BSK1...72S
normally open fire-resisting duct damper with mechanical drive mechanism.

Design

- The **BSK1** series dampers are made in the general-purpose industrial version with a minimized variety of hardware components using low-alloy galvanized steel. The damper flap is made of fire-resistant material.
- The duct installation design results in two mounting flanges on the casing for integration into a ventilation duct (air ducting) and external configuration of the drive mechanism for easier maintenance.
- The **BSK1** series dampers are characterised by a simplified design and the absence of a hot and cold zone baffle.

Control and modifications

- Depending on the design variant BSK1 series dampers are equipped with:

MECHANICAL ACTUATING UNIT WITH A THERMAL FUSE AND A RETURN SPRING

- The damper is set to the operating position upon the thermal fuse breakdown resulting from a temperature increase.
- Emergency damper actuation: the flap remains in protective position (damper unaffected by fire) and is fixed by a thermal fuse (when the flap is installed in security position, a reverse spring is activated). Upon emergency actuation (damper directly affected by fire) the thermal fuse breaks down and the return spring moves the flap to operating position.

ELECTRIC ACTUATOR WITH A BUILT-IN RETURN SPRING AND A BACK-UP THERMAL BREAKER

- Setting the damper to operating position (direct fire contact): remotely, via an electric actuator. The damper can be set to the operating or protective position either remotely via a control panel or manually using a manual cocking handle which is always included in the standard delivery set of the electric actuator. In case of the remote control panel failure, the back-up thermal breaker interrupts the power supply to the electric actuator and the return spring sets the damper to the operating position.
- Emergency damper actuation: the damper flap is set to the protective position automatically (damper unaffected by fire). The electric actuator remains energized at all times.
- In case of an emergency actuation (direct fire contact), the electric actuator equipped with a return spring is de-energized and the damper flap is set to the operating position by means of the spring energy. In case of a power failure not related to fire and its subsequent restoration at the actuator with a return spring, the damper flap returns to protective position.

Designation key

BSK 1 20 x30 / 2 PVP24T / O

Series:
Fire-resisting damper

Fire resistance rating:
1: 1 hour

Damper flow area width [cm]:
20; 25; 30; 40; 50; 60; 80; 100

Damper flow area height [cm]:
20; 25; 30; 40; 50; 60; 80; 100

Number of flanges:
1: one
2: two

Actuator type:
72S: thermal fuse and return spring (manual actuation)
PKP24T: 24 V ZERN electric actuator with a return spring and a thermal breaker
PVP24T: 24 V BELIMO electric actuator with a return spring and a thermal breaker
PSP230T: 230 V BELIMO electric actuator with a return spring and a thermal breaker
PSP24T: 24 V SIEMENS electric actuator with a return spring and a thermal breaker
PSP230T: 230 V SIEMENS electric actuator with a return spring and a thermal breaker

Actuator location:
O: outside
I: inside (except for dampers with height or width less than 30 cm)

BSK1...72S FIRE SAFETY DAMPER WITH A MECHANICAL ACTUATING UNIT WITH A THERMAL FUSE AND A RETURN SPRING

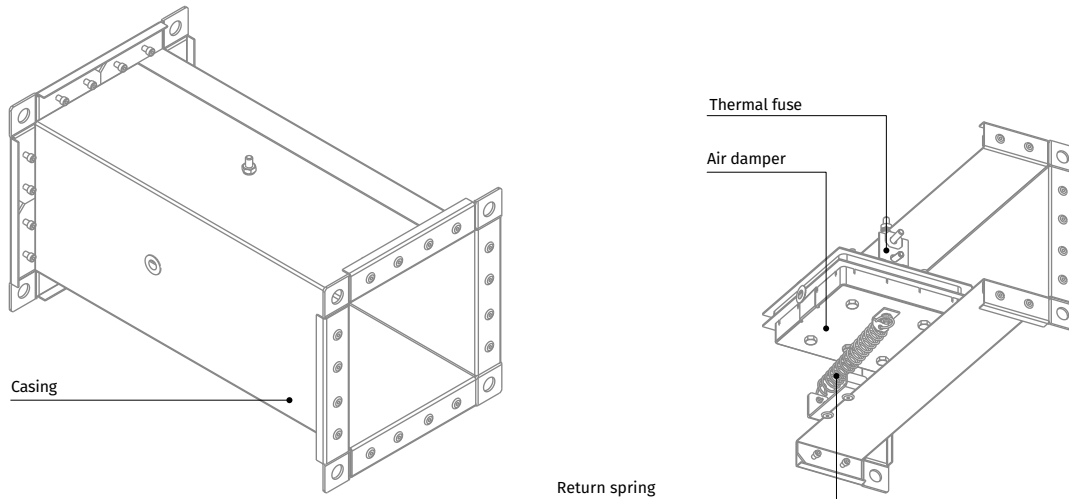

BSK1...PKP/BSK1...PVP/BSK1...PSP FIRE SAFETY DAMPER WITH A BELIMO ELECTRIC ACTUATOR AND A THERMOELECTRIC BREAKER

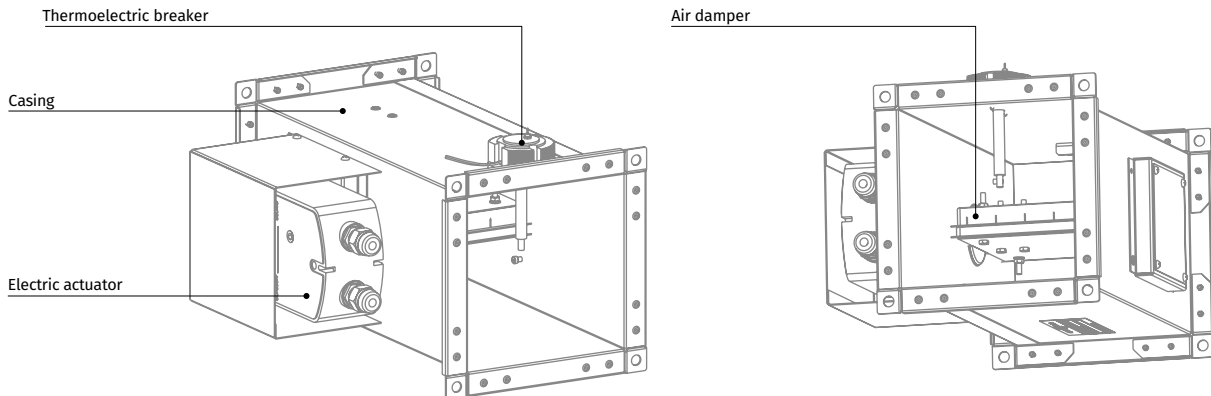

Mounting

- The damper must be installed into the building envelope structure in accordance with the applicable standards and regulations. The seal fire resistance must be at least equal to that of the building envelope.
- The dampers can be installed in any position in vertical and horizontal ducts of fire-protection structures. The ducts for damper installation must be made in such a way so as to prevent the transfer of loads caused by the fire-protection structures to the damper casing. The adjoining air duct must be suspended in such a way so as to prevent the transfer of air duct load to the damper flange. The minimum free space for accessing the control parts must be at least 350 mm. Make sure to arrange an inspection hole. While carrying out the installation consider size K. When two or more dampers are installed into the same fire-protection separation structure, the distance between the two adjacent dampers must be at least 200 mm.
- The damper must be installed in such a way that the damper flap (in its closed position) lies in the fire-protection divider structure plane. If such installation is not possible, the damper casing part between the fire-protection separation structure and the damper flap must be insulated with a suitable material pursuant to the applicable standards.
- The damper control mechanism must be protected against damage and contamination. The damper casing must not deform any deformation during embedding. After the installation the flap must not catch against the damper casing while opening or closing. The fire safety damper can be integrated into a tight wall structure - e.g. made of conventional concrete work of minimum width $W = 100$ mm or into a plasterboard wall of the necessary fire resistance class or into a tight ceiling structure - e.g. made of conventional concrete of minimum width $W = 150$ mm. Do not use any foaming substances for sealing the damper in the separation structure.

INSTALLATION RECOMMENDATIONS FOR BSK1...72S DAMPERS WITH THERMAL FUSE AND RETURN SPRING:

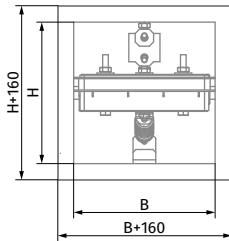

For Sizes B and H please refer to the dimension table

IN VERTICAL BUILDING STRUCTURES

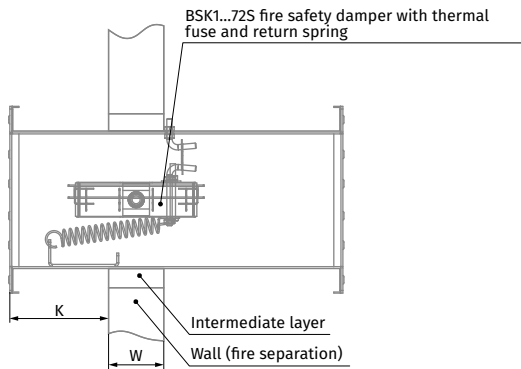

IN HORIZONTAL BUILDING STRUCTURES

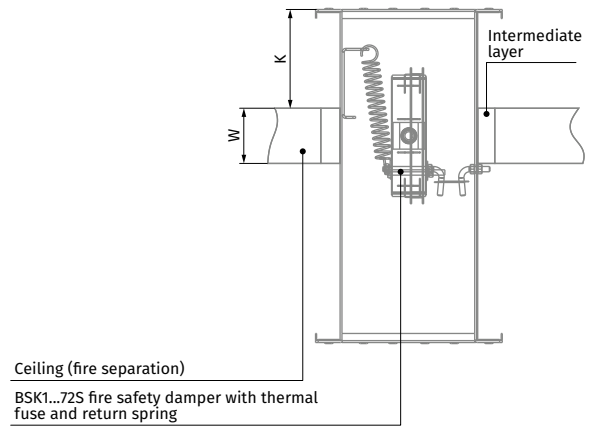

DUCT MODIFICATION WITH AN AIR DUCT

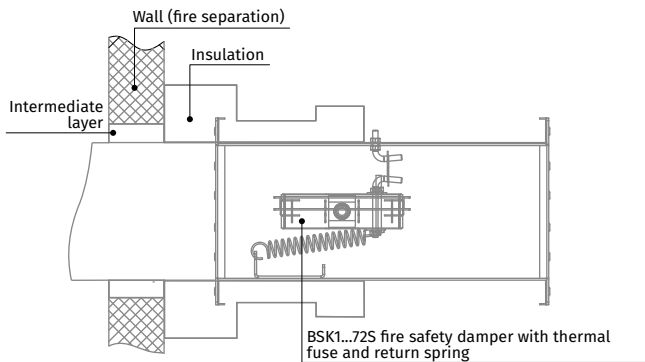

INSTALLATION RECOMMENDATIONS FOR BSK1...PKP/BSK1...PVP/BSK1...PSP FIRE SAFETY DAMPERS WITH ELECTRIC ACTUATOR AND THERMOELECTRIC BREAKER

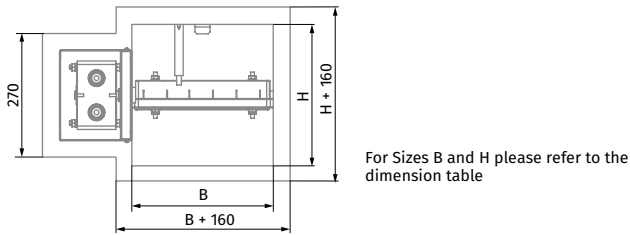

IN VERTICAL BUILDING STRUCTURES

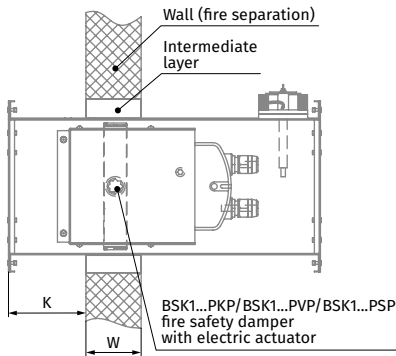

IN HORIZONTAL BUILDING STRUCTURES

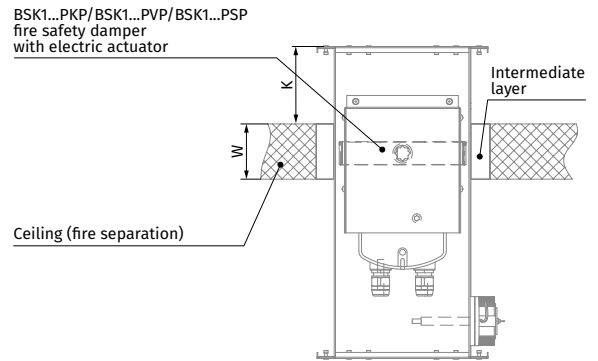

DUCT MODIFICATION WITH AN AIR DUCT

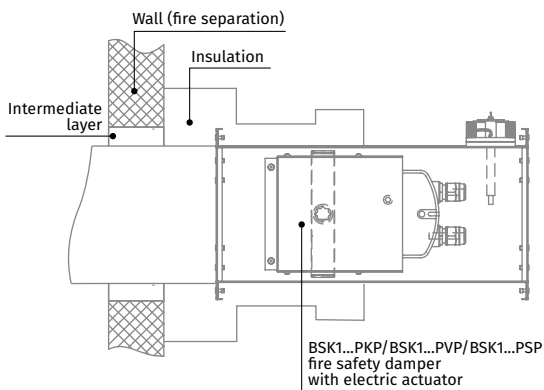

Overall and connecting dimensions

BSK1...72S DAMPERS WITH MECHANICAL ACTUATOR

Duct cross-section	Dimensions [mm]						Weight [kg]
	B	B1	B2	H	H1	H2	
BSK1 20x20/2 72S/O	200	220	240	200	220	240	3.5
BSK1 25x20/2 72S/O	250	270	290	200	220	240	4
BSK1 25x25/2 72S/O	250	270	290	250	270	290	4.5
BSK1 30x20/2 72S/O	300	320	340	200	220	240	4.5
BSK1 30x25/2 72S/O	300	320	340	250	270	290	5.1
BSK1 30x30/2 72S/O	300	320	340	300	320	340	5.8
BSK1 40x25/2 72S/O	400	420	440	250	270	290	6.3
BSK1 40x30/2 72S/O	400	420	440	300	320	340	7.1
BSK1 40x40/2 72S/O	400	420	440	400	420	440	8.7
BSK1 50x30/2 72S/O	500	520	540	300	320	340	8.5
BSK1 50x40/2 72S/O	500	520	540	400	420	440	10.3
BSK1 50x50/2 72S/O	500	520	540	500	520	540	12
BSK1 60x40/2 72S/O	600	620	640	400	420	440	11.9
BSK1 60x50/2 72S/O	600	620	640	500	520	540	13.8
BSK1 60x60/2 72S/O	600	620	640	600	620	640	16.1

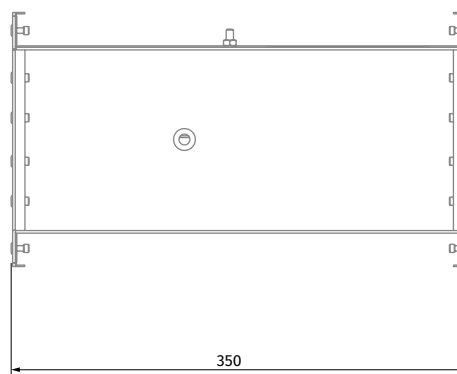
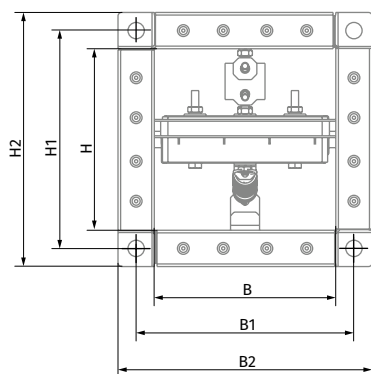

FLOW AREA OF FIRE-RESISTING DUCT DAMPER WITH MECHANICAL ACTUATOR [m²]

B/H [mm]	200	250	300	400	500	600
200	0.032					
250	0.04	0.053				
300	0.048	0.063	0.078			
400	0.064	0.084	0.104	0.144		
500	0.08	0.105	0.13	0.18	0.23	
600	0.096	0.126	0.156	0.216	0.276	0.336

Dampers with dimensions not included in the table can be produced on request.
Limit damper size: 600x600 mm

Overall and connecting dimensions

BSK1...PKP/BSK1...PVP/BSK1...PSP DAMPERS WITH ELECTRIC ACTUATORS

Duct cross-section	Dimensions [mm]							Weight [kg]
	B	B1	B2	B3	H	H1	H2	
BSK1 20x20/2 .../O	200	220	240	325	200	220	240	6.2
BSK1 25x20/2 .../O	250	270	290	375	200	220	240	6.8
BSK1 25x25/2 .../O	250	270	290	375	250	270	290	7.3
BSK1 30x20/2 .../O	300	320	340	425	200	220	240	7.3
BSK1 30x25/2 .../O	300	320	340	425	250	270	290	7.9
BSK1 30x30/2 .../O	300	320	340	425	300	320	340	8.5
BSK1 40x25/2 .../O	400	420	440	525	250	270	290	9.1
BSK1 40x30/2 .../O	400	420	440	525	300	320	340	9.8
BSK1 40x40/2 .../O	400	420	440	525	400	420	440	11.3
BSK1 50x30/2 .../O	500	520	540	625	300	320	340	10.7
BSK1 50x40/2 .../O	500	520	540	625	400	420	440	12.9
BSK1 50x50/2 .../O	500	530	560	635	500	530	560	16.6
BSK1 60x40/2 .../O	600	620	640	725	400	420	440	14.5
BSK1 60x50/2 .../O	600	630	660	735	500	530	560	18.4
BSK1 60x60/2 .../O	600	630	660	735	600	630	660	20.6
BSK1 80x50/2 .../O	800	830	860	935	500	530	560	22.3
BSK1 80x60/2 .../O	800	830	860	935	600	630	660	24.8
BSK1 80x80/2 .../O	800	830	860	935	800	830	860	30.1
BSK1 100x60/2 .../O	1000	1030	1060	1135	600	630	660	29
BSK1 100x80/2 .../O	1000	1030	1060	1135	800	830	860	35.4
BSK1 100x100/2 .../O	1000	1030	1060	1135	1000	1030	1060	41.7

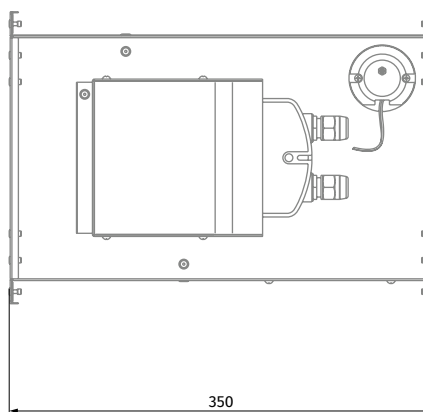
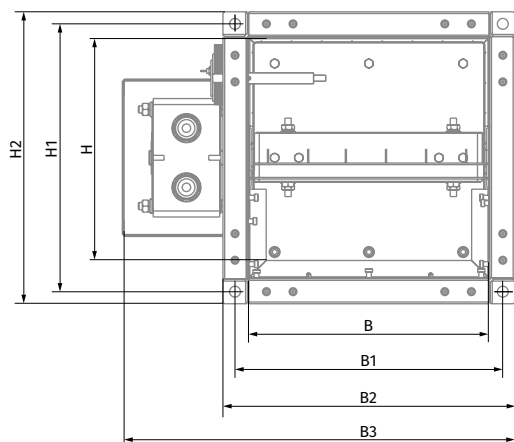

Note: The values given in the table for dampers with 230 V actuators are identical for those equipped with 24 V actuators.

FIRE SAFETY DAMPERS

FLOW AREA OF THE DUCT FIRE-RESISTANT DAMPER WITH AN ELECTRIC ACTUATOR INSTALLED OUTSIDE THE DAMPER [M²]

B/H [mm]	200	250	300	400	500	600	800	1000
200	0.032							
250	0.04	0.053						
300	0.048	0.063	0.078					
400	0.064	0.084	0.104	0.144				
500	0.08	0.105	0.13	0.18	0.23			
600	0.096	0.126	0.156	0.216	0.276	0.336		
800	0.128	0.168	0.208	0.288	0.368	0.448	0.608	
1000	0.16	0.21	0.26	0.36	0.46	0.56	0.76	0.96

Dampers with dimensions not included in the table can be produced on request.
Limit damper size: 1000x1000 mm

Technical data
BELIMO ELECTRIC ACTUATORS WITH A RETURN SPRING AND A THERMAL BREAKER

Parameters	Basic models		Models with increased torque		Models with the highest torque	
Rated voltage [V]	AC/DC 24	AC 230	AC/DC 24	AC 230	AC/DC 24	AC 230
Rated voltage range [V]	AC 19.2...28.8 DC 21.6...28.8	AC 198...264	AC 19.2...28.8 DC 21.6...28.8	AC 198...264	AC 19.2...28.8 DC 21.6...28.8	AC 198...264
Rated voltage frequency AC [Hz]	50/60		50/60		50/60	
Power consumption in rest position [W]	0.8	1.1	1.4	2.1	2	3
Power consumption in operation [W]	2.5	3.5	4	5	7	8.5
Maximum design capacity [VA]	4	6.5	6	10	10	11
Motor torque [Nm]	4		9		18	
Spring torque [Nm]	3		7		12	
Protection class	III	II	III	II	III	II
Ingress protection rating	IP54	IP54	IP54	IP54	IP54	IP54
Auxiliary switches	2 pcs., single-pole, reversible, 1 mA...3(0,5)A, AC 250 V				2 pcs., single-pole, reversible, 1 mA...6(3)A, AC 250 V	
Electric motor connection cable	1 m, 2 x 0.75 mm ² (halogen-free)					
Auxiliary switch connection cable	1 m, 6 x 0.75 mm ² (halogen-free)					
Running time spring	20 seconds at -10...+55 °C < 60 seconds at -30...-10 °C		20 seconds at -10...+55 °C < 60 seconds at -30...-10 °C		16 seconds at +20 °C	
Running time motor	< 60 s/90°		< 60 s/90°		< 120 s/90°	
Response temperature of thermal breaker sensors	Duct sensor 72 °C Outdoor sensor 72 °C					
Service life	Min. 60 000 emergency positions					
Technical maintenance	Not required					

ZERN ELECTRIC ACTUATORS WITH A RETURN SPRING AND A THERMAL BREAKER

Parameters	Basic models		Models with increased torque	
Rated voltage [V]	AC/DC 24	AC 100–240	AC/DC 24	AC 100–240
Rated voltage range [V]	AC/DC 19.2...28.8	AC 85...265	AC/DC 19.2...28.8	AC 85...265
Rated voltage frequency AC [Hz]	50/60		50/60	
Power consumption in rest position [W]	3		3	
Power consumption in operation [W]	5		5	
Motor torque [Nm]	5		8	
Spring torque [Nm]	5		8	
Protection class	III	II	III	II
Ingress protection rating	IP54	IP54	IP54	IP54
Auxiliary switches	2 pcs., single-pole, reversible, 1 mA...3(0,5)A, AC 220 V			
Electric motor connection cable	1 m, 2 x 0.5 mm ² (halogen-free)			
Auxiliary switch connection cable	1 m, 6 x 0.5 mm ² (halogen-free)			
Running time spring	<20 seconds < 60 seconds at -30...-10 °C		<25 seconds < 60 seconds at -30...-10 °C	
Running time motor	< 70 s/95°		< 100 s/95°	
Response temperature of thermal breaker sensors	Duct sensor 72 °C Outdoor sensor 72 °C			

SIEMENS ELECTRIC ACTUATORS WITH A RETURN SPRING AND A THERMAL BREAKER

Parameters	Basic models		Models with increased torque		Models with the highest torque	
Rated voltage [V]	AC 24/ DC 24...48	AC 230	AC 24/ DC 24...48	AC 230	AC 24/ DC 24...48	AC 230
Rated voltage range [V]	AC/DC ±20 %	AC ±15 %	AC/DC ±20 %	AC ±15 %	AC/DC ±20 %	AC ±15 %
Rated voltage frequency AC [Hz]	50/60		50/60		50/60	
Power consumption in rest position [W]	2	3.5	2	3.5	3	4
Power consumption in operation [W]	3.5	4.5	3.5	4.5	5	6
Maximum design capacity [VA]	5	7	5	7	7	8
Motor torque [Nm]	4		9		18	
Spring torque [Nm]	4		7		18	
Protection class	III	II	III	II	III	II
Ingress protection rating	IP54	IP54	IP54	IP54	IP54	IP54
Auxiliary switches	2 pcs., single-pole, reversible, 6(2)A, AC 24...250 V					
Electric motor connection cable	0.9 m, 2 x 0.75 mm ² (halogen-free)					
Auxiliary switch connection cable	0.9 m, 6 x 0.75 mm ² (halogen-free)					
Running time spring	15 seconds < 60 seconds at -30...-10 °C					
Running time motor	90 s/90°					
Response temperature of thermal breaker sensors	Duct sensor 72 °C Outdoor sensor 72 °C					
Service life	10 000 emergency positions					
Technical maintenance	Not required					

Electrical connection

BASIC MODELS OF BELIMO AND ZERN ELECTRIC ACTUATORS. BELIMO AND ZERN MODELS WITH INCREASED TORQUE

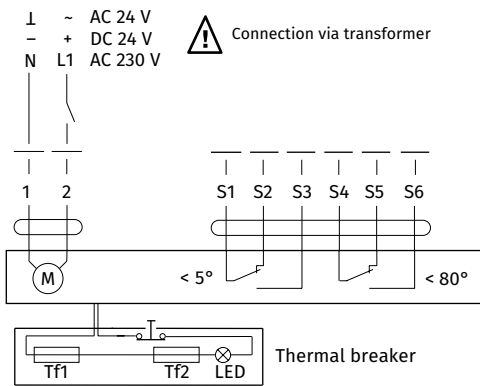

BELIMO ELECTRIC ACTUATORS WITH THE HIGHEST TORQUE, SIEMENS ELECTRIC ACTUATORS

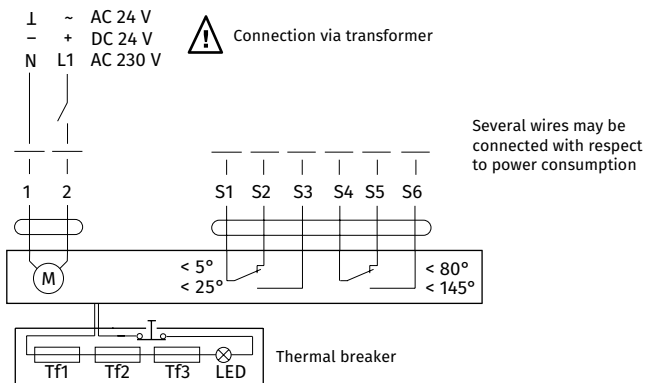

BSK2

Fire-resisting dampers

Use

- The fire-resisting dampers are intended for automatic closing of process openings and air duct penetrations in intermediate floors, walls and partitions, as well as closing of openings in supply and exhaust ducts of smoke ventilation systems. The dampers of this particular design are not suitable for installation in air ducts and ducts of premises with rated explosion and fire safety category A and B and in flammable and explosive mixture intakes. The **BSK2** fire-resisting duct dampers are capable of resisting fire for at least 120 minutes (EI 120) at the temperature of 600 °C.

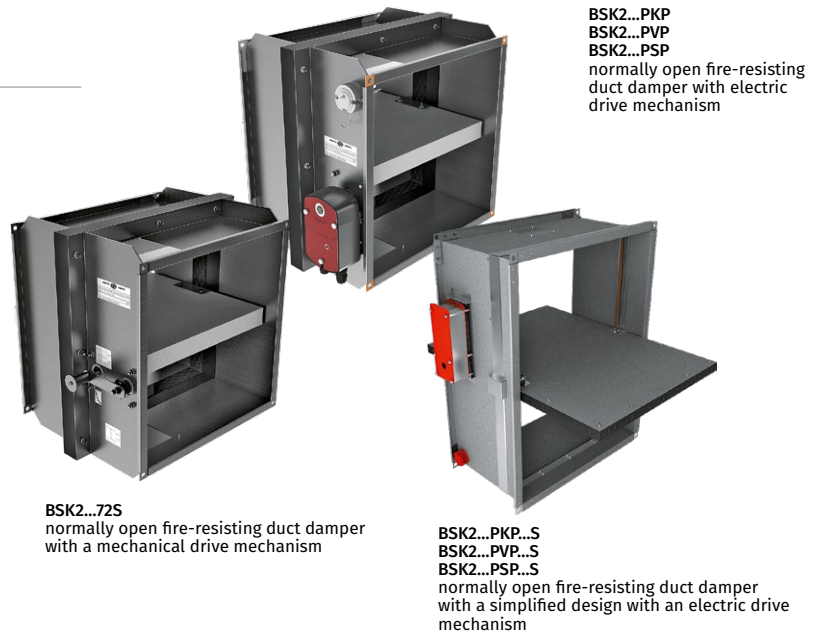

BSK2...72S
normally open fire-resisting duct damper with a mechanical drive mechanism

BSK2...PKP
BSK2...PVP
BSK2...PSP
normally open fire-resisting duct damper with electric drive mechanism

BSK2...PKP...S
BSK2...PVP...S
BSK2...PSP...S
normally open fire-resisting duct damper with a simplified design with an electric drive mechanism

Design

- The **BSK2** series dampers are made in the general-purpose industrial version with a minimized variety of hardware components using low-alloy galvanized steel. The damper flap is made of fire-resistant material.
- The duct installation design results in two mounting flanges on the casing for integration into a ventilation ducts (air ducting) and external configuration of the drive mechanism for easier maintenance.
- The **BSK2...PKP/ BSK2...PVP/ BSK2...PSP** dampers are equipped with a hot and cold zone baffle.
- The **BSK2...PKP...S/ BSK2...PVP...S/ BSK2...PSP...S** dampers have a simplified construction:
 - Simplified damper swing mechanism
 - The zone baffle has been replaced by casing perforation covered with ceramic fibre material and aluminium foil tape
 - New material and altered flap thickness.

Control and modifications

- Depending on the design variant the **BSK2** series dampers are equipped with:

MECHANICAL ACTUATING UNIT WITH A THERMAL FUSE AND A RETURN SPRING

- The damper is set to the operating position upon the thermal fuse breakdown resulting from a temperature increase. The damper can then be re-set to the protective position only manually by using a handle and by replacing the thermal fuse through the access hole.
- Emergency damper actuation: the flap remains in protective position (damper unaffected by fire) and is fixed by a thermal fuse (when the flap is installed in security position, a reverse spring is activated). Upon emergency actuation (damper directly affected by fire) the thermal fuse breaks down and the return spring moves the flap to operating position.

ELECTRIC ACTUATOR WITH A BUILT-IN RETURN SPRING AND A BACK-UP THERMAL BREAKER

- Setting the damper to operating position (direct fire contact): remotely, via electric actuator. The damper can be set to the operating or protective position either remotely via the control panel or manually using the manual cocking handle which is always included in the standard delivery set of the electric actuator.
- In case of the remote control panel failure, the back-up thermal breaker interrupts the power supply to the electric actuator and the return spring sets the damper to the operating position.
- Emergency damper actuation: The damper flap is set to the protective position automatically (damper unaffected by fire). The electric actuator remains energized at all times.
- In case of an emergency actuation (direct fire contact), the electric actuator equipped with a return spring is de-energized and the damper flap is set to the operating position by means of the spring energy. In case of a power failure not related to fire and its subsequent restoration at the actuator with a return spring, the damper flap returns to protective position.

Designation key

BSK 2 20x30 / 2 PVP24T / O S

Series:
Fire-resisting damper

Fire resistance:
2: 2 hours

Damper flow area width [cm]:
20; 25; 30; 40; 50; 60; 80; 100

Damper flow area height [cm]:
20; 25; 30; 40; 50; 60; 80; 100

Number of flanges:
1: one
2: two

Actuator type:
72S: thermal fuse and return spring (manual actuation)
PKP24T: 24 V ZERN electric actuator with a return spring and a thermal breaker
PKP230T: 230 V ZERN electric actuator with a return spring and a thermal breaker
PVP24T: 24 V BELIMO electric actuator with a return spring and a thermal breaker
PVP230T: 230 V BELIMO electric actuator with a return spring and a thermal breaker
PSP24T: 24 V SIEMENS electric actuator with a return spring and a thermal breaker
PSP230T: 230 V SIEMENS electric actuator with a return spring and a thermal breaker

Actuator location:
O: outside
I: inside (except for dampers with height or width less than 30 cm)

Design variant:
_: ordinary damper design
S: simplified damper design

THE BSK2...72S FIRE SAFETY DAMPER WITH A MECHANICAL ACTUATING UNIT WITH A THERMAL FUSE AND A RETURN SPRING

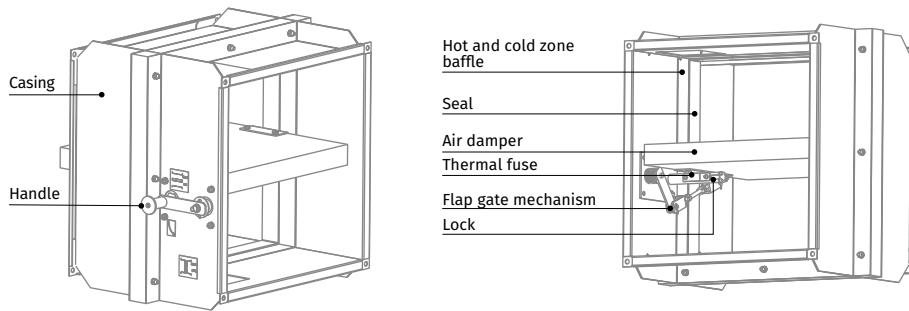

THE BSK2...PKP/BSK2...PVP/BSK2...PSP FIRE SAFETY DAMPER WITH ELECTRIC ACTUATOR AND THERMOELECTRIC BREAKER

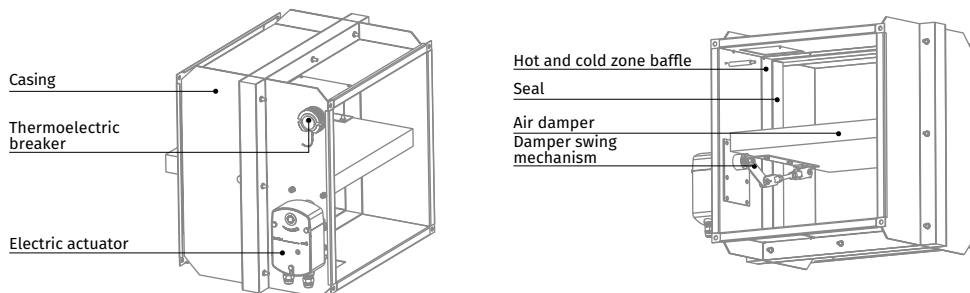

THE BSK2...PKP...S/BSK2...PVP...S/BSK2...PSP...S FIRE SAFETY DAMPER WITH BELIMO ELECTRIC ACTUATOR AND THERMOELECTRIC BREAKER

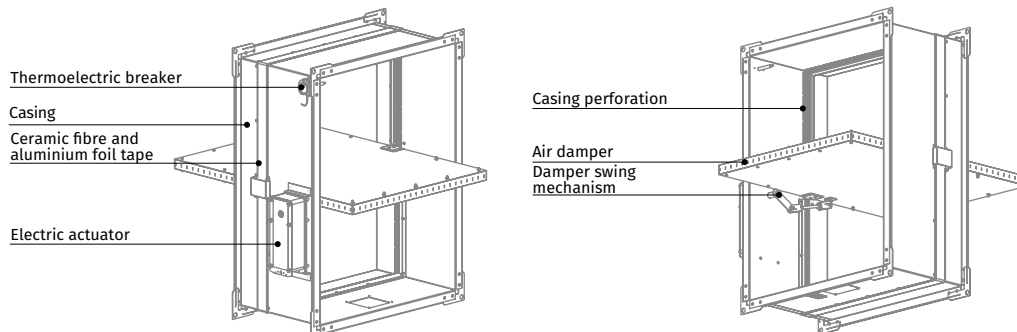

FIRE SAFETY DAMPERS

Mounting

- The damper must be installed into the building envelope structure in accordance with the applicable standards and regulations. The seal fire resistance must be at least equal to that of the building envelope.
- The dampers can be installed in any position in vertical and horizontal ducts of fire-protection structures. The ducts for damper installation must be made in such a way so as to prevent the transfer of loads caused by the fire-protection structures to the damper casing. The adjoining air duct must be suspended in such a way so as to prevent the transfer of air duct load to the damper flange. The minimum free space for accessing the control parts must be at least 350 mm. Make sure to arrange an inspection hole. While carrying out the installation consider size K. When two or more dampers are installed into the same fire-protection separation structure, the distance between the two adjacent dampers must be at least 200 mm.
- If such installation is not possible, the damper casing part between the fire-protection separation space and the damper flap must be insulated with a suitable material pursuant to the applicable standards. If such installation is not possible, the damper casing part between the fire-protection separation structure and the damper flap must be insulated with a suitable material pursuant to the applicable standards.
- The damper casing must not deform any deformation during embedding. After the installation the flap must not catch against the damper casing while opening or closing. The fire safety damper can be integrated into a tight wall structure – e.g. made of conventional concrete work of minimum width $W = 100$ mm or into a plasterboard wall of the necessary fire resistance class or into a tight ceiling structure – e.g. made of conventional concrete of minimum width $W = 150$ mm. Do not use any foaming substances for sealing the damper in the separation structure.

INSTALLATION RECOMMENDATIONS FOR BSK2...72S DAMPERS WITH THERMAL FUSE AND RETURN SPRING

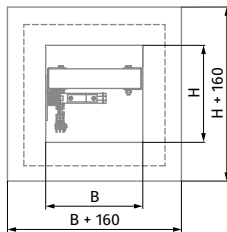

For Sizes B and H please refer to the dimension table

IN VERTICAL BUILDING STRUCTURES

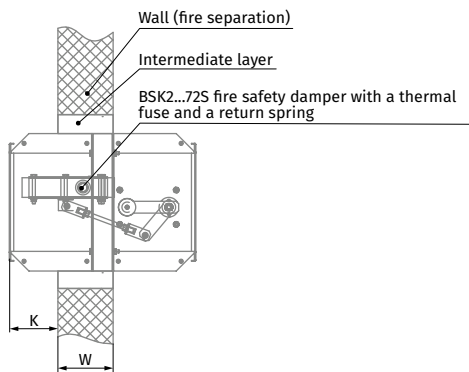

IN HORIZONTAL BUILDING STRUCTURES

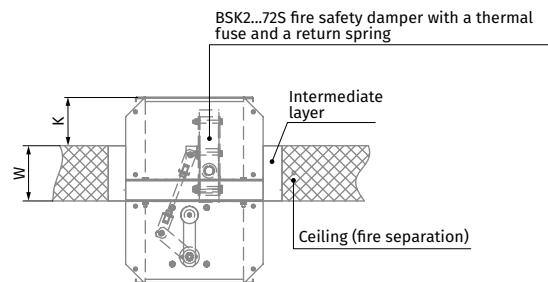

INSTALLATION RECOMMENDATIONS FOR BSK2...PKP/ BSK2...PVP/ BSK2...PSP FIRE SAFETY DAMPERS WITH AN ELECTRIC ACTUATOR AND THERMOELECTRIC BREAKER

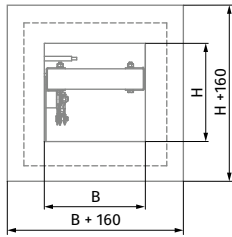

For Sizes B and H please refer to the dimension table

IN HORIZONTAL BUILDING STRUCTURES

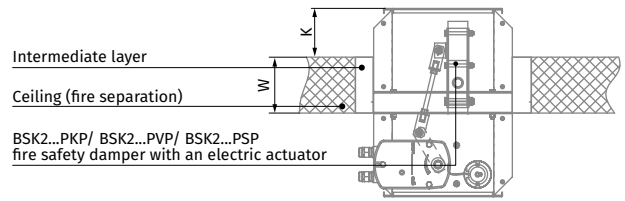

IN VERTICAL BUILDING STRUCTURES

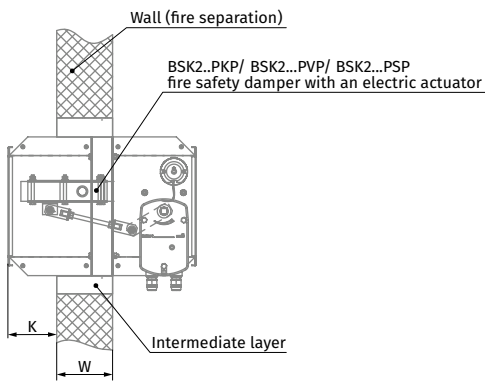

DUCT MODIFICATION WITH AN AIR DUCT

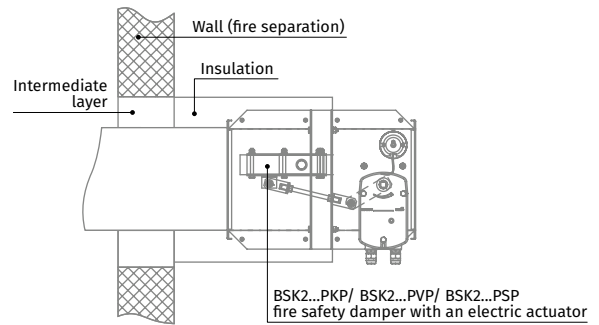

INSTALLATION RECOMMENDATIONS FOR BSK2...PKP...S/ BSK2...PVP...S/BSK2...PSP...S FIRE SAFETY DAMPERS WITH AN ELECTRIC ACTUATOR AND THERMOELECTRIC BREAKER

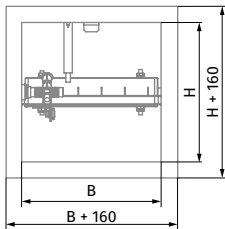

For Sizes B and H please refer to the dimension table

IN VERTICAL BUILDING STRUCTURES

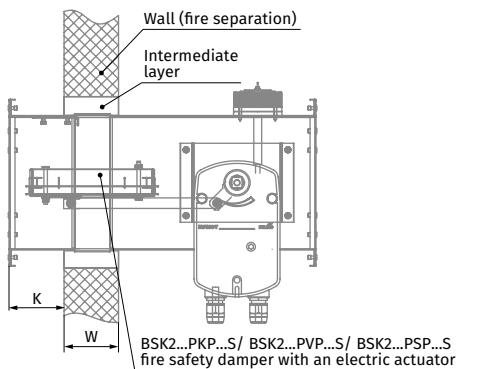

DUCT MODIFICATION WITH AN AIR DUCT

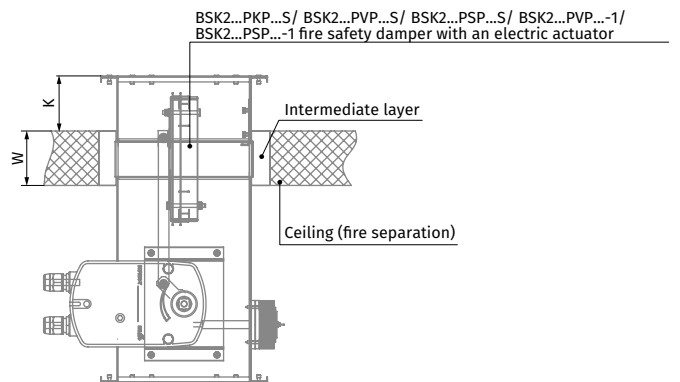

Overall and connecting dimensions

BSK2...72S DAMPERS WITH A MECHANICAL ACTUATOR

Duct cross-section	Dimensions [mm]									Weight [kg]
	B	B1	B2	B3	H	H1	H2	H3	S	
BSK2 20x20/2 72S/O	200	220	240	280	200	220	240	280	315	12
BSK2 25x20/2 72S/O	250	270	290	330	200	220	240	280	365	13
BSK2 25x25/2 72S/O	250	270	290	330	250	270	290	330	365	14.1
BSK2 30x20/2 72S/O	300	320	340	380	200	220	240	280	415	14
BSK2 30x25/2 72S/O	300	320	340	380	250	270	290	330	415	15.3
BSK2 30x30/2 72S/O	300	320	340	380	300	320	340	380	415	18.8
BSK2 40x25/2 72S/O	400	420	440	480	250	270	290	330	515	19.2
BSK2 40x30/2 72S/O	400	420	440	480	300	320	340	380	515	19.7
BSK2 40x40/2 72S/O	400	420	440	480	400	420	440	480	515	22
BSK2 50x30/2 72S/O	500	520	540	580	300	320	340	380	615	22.5
BSK2 50x40/2 72S/O	500	520	540	580	400	420	440	480	615	24.7
BSK2 50x50/2 72S/O	500	520	540	580	500	520	540	580	615	29.8
BSK2 60x40/2 72S/O	600	620	640	680	400	420	440	480	715	29.7
BSK2 60x50/2 72S/O	600	620	640	680	500	520	540	580	715	36
BSK2 60x60/2 72S/O	600	620	640	680	600	620	640	680	715	38

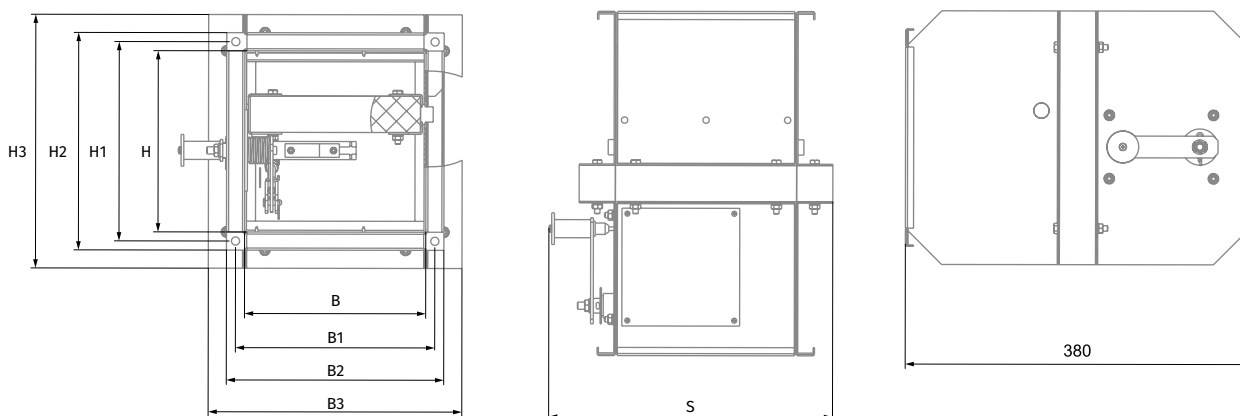

FLOW AREA OF FIRE-RESISTING DUCT DAMPER WITH MECHANICAL ACTUATOR [m²]

B/H [mm]	200	250	300	400	500	600
200	0.032					
250	0.04	0.053				
300	0.048	0.063	0.078			
400	0.064	0.084	0.104	0.144		
500	0.08	0.105	0.13	0.18	0.23	
600	0.096	0.126	0.156	0.216	0.276	0.336

Dampers with dimensions not included in the table can be produced on request.
Limit damper size: 600x600 mm.

Overall and connecting dimensions

BSK2...PKP/BSK2...PVP/BSK2...PSP DAMPERS WITH ELECTRIC ACTUATORS

Duct cross-section	Dimensions [mm]									Weight [kg]
	B	B1	B2	B3	H	H1	H2	H3	S	
BSK2 20x20/2 .../O	200	220	240	280	200	220	240	280	340	13.3
BSK2 25x20/2 .../O	250	270	290	330	200	220	240	280	390	14.3
BSK2 25x25/2 .../O	250	270	290	330	250	270	290	330	390	15.4
BSK2 30x20/2 .../O	300	320	340	380	200	220	240	280	440	15.3
BSK2 30x25/2 .../O	300	320	340	380	250	270	290	330	440	16.6
BSK2 30x30/2 .../O	300	320	340	380	300	320	340	380	440	20.1
BSK2 40x25/2 .../O	400	420	440	480	250	270	290	330	540	20.5
BSK2 40x30/2 .../O	400	420	440	480	300	320	340	380	540	21
BSK2 40x40/2 .../O	400	420	440	480	400	420	440	480	540	23.3
BSK2 50x30/2 .../O	500	520	540	580	300	320	340	380	640	23.8
BSK2 50x40/2 .../O	500	520	540	580	400	420	440	480	640	26
BSK2 50x50/2 .../O	500	530	560	580	500	530	560	580	650	33
BSK2 60x40/2 .../O	600	620	640	680	400	420	440	480	740	32.7
BSK2 60x50/2 .../O	600	630	660	680	500	530	560	580	750	38.4
BSK2 60x60/2 .../O	600	630	660	680	600	630	660	680	750	43
BSK2 80x50/2 .../O	800	830	860	880	500	530	560	580	950	47
BSK2 80x60/2 .../O	800	830	860	880	600	630	660	680	950	52
BSK2 80x80/2 .../O	800	830	860	880	800	830	860	880	950	63
BSK2 100x60/2 .../O	1000	1030	1060	1080	600	630	660	680	1150	63
BSK2 100x80/2 .../O	1000	1030	1060	1080	800	830	860	880	1150	75
BSK2 100x100/2 .../O	1000	1030	1060	1080	1000	1030	1060	1080	1150	87

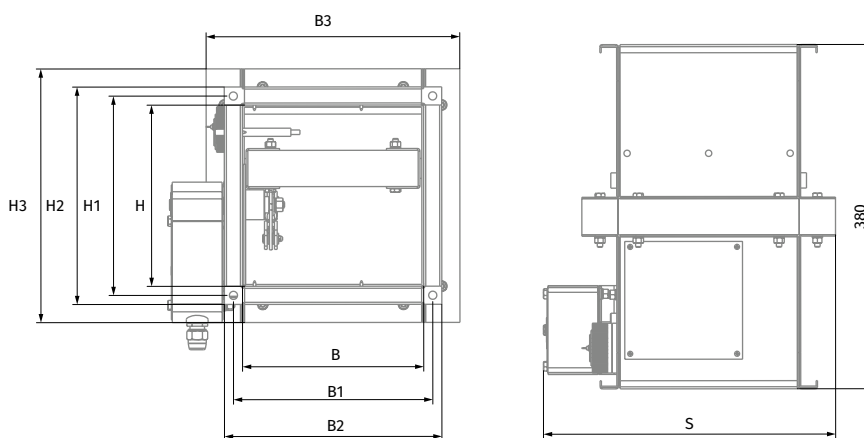

Note: The values given in the table for dampers with 230 V actuators are identical for those equipped with 24 V.

FLOW AREA OF THE DUCT FIRE-RESISTANT DAMPER WITH AN ELECTRIC ACTUATOR INSTALLED OUTSIDE THE DAMPER [M²]

B/H [mm]	200	250	300	400	500	600	800	1000
200	0.032							
250	0.04	0.053						
300	0.048	0.063	0.078					
400	0.064	0.084	0.104	0.144				
500	0.08	0.105	0.13	0.18	0.23			
600	0.096	0.126	0.156	0.216	0.276	0.336		
800	0.128	0.168	0.208	0.288	0.368	0.448	0.608	
1000	0.16	0.21	0.26	0.36	0.46	0.56	0.76	0.96

Dampers with dimensions not included in the table can be produced on request.
Limit damper size: 1000x1000 mm

Overall and connecting dimensions

BSK2...PKP...S/BSK2...PVP...S/BSK2...PSP...S DAMPERS WITH ELECTRIC ACTUATORS:

Duct cross-section	Dimensions [mm]							Weight [kg]
	B	B1	B2	B3	H	H1	H2	
BSK2 20x20/2 .../O S	200	220	240	340	200	220	240	5.7
BSK2 25x20/2 .../O S	250	270	290	390	200	220	240	6.2
BSK2 25x25/2 .../O S	250	270	290	390	250	270	290	6.9
BSK2 30x20/2 .../O S	300	320	340	440	200	220	240	6.8
BSK2 30x25/2 .../O S	300	320	340	440	250	270	290	7.5
BSK2 30x30/2 .../O S	300	320	340	440	300	320	340	9.2
BSK2 40x25/2 .../O S	400	420	440	540	250	270	290	9
BSK2 40x30/2 .../O S	400	420	440	540	300	320	340	10.8
BSK2 40x40/2 .../O S	400	420	440	540	400	420	440	12.6
BSK2 50x30/2 .../O S	500	520	540	640	300	320	340	12.3
BSK2 50x40/2 .../O S	500	520	540	640	400	420	440	14.3
BSK2 50x50/2 .../O S	500	530	560	650	500	530	560	23
BSK2 60x40/2 .../O S	600	620	640	740	400	420	440	16.2
BSK2 60x50/2 .../O S	600	630	660	750	500	530	560	25.6
BSK2 60x60/2 .../O S	600	630	660	750	600	630	660	28.6
BSK2 80x50/2 .../O S	800	830	860	950	500	530	560	31.3
BSK2 80x60/2 .../O S	800	830	860	950	600	630	660	34.7
BSK2 80x80/2 .../O S	800	830	860	950	800	830	860	42
BSK2 100x60/2 .../O S	1000	1030	1060	1150	600	630	660	40.7
BSK2 100x80/2 .../O S	1000	1030	1060	1150	800	830	860	50.2
BSK2 100x100/2 .../O S	1000	1030	1060	1150	1000	1030	1060	58

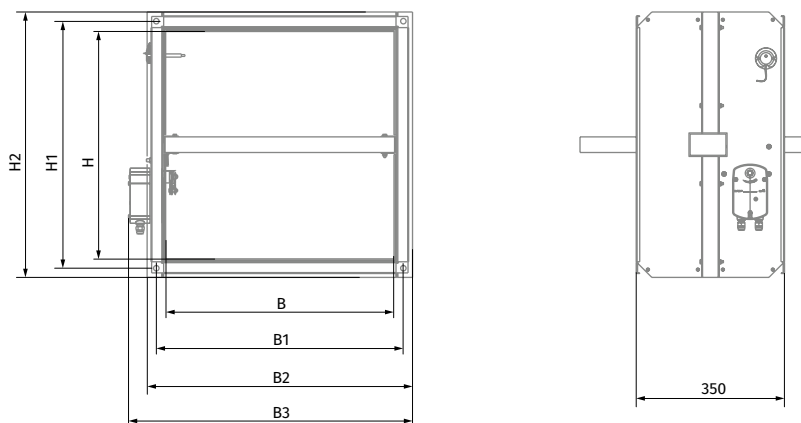

Note: The values given in the table for dampers with 230 V actuators are identical for those equipped with 24 V.

FLOW AREA OF THE DUCT FIRE-RESISTANT DAMPER WITH AN ELECTRIC ACTUATOR INSTALLED OUTSIDE THE DAMPER [m²]

B/H [mm]	200	250	300	400	500	600	800	1000
200	0.032							
250	0.04	0.053						
300	0.048	0.063	0.078					
400	0.064	0.084	0.104	0.144				
500	0.08	0.105	0.13	0.18	0.23			
600	0.096	0.126	0.156	0.216	0.276	0.336		
800	0.128	0.168	0.208	0.288	0.368	0.448	0.608	
1000	0.16	0.21	0.26	0.36	0.46	0.56	0.76	0.96

Dampers with dimensions not included in the table can be produced on request.
 Limit damper size: 1000x1000 mm

Technical data
BELIMO ELECTRIC ACTUATORS WITH A RETURN SPRING AND A THERMAL BREAKER

Parameters	Basic models		Models with increased torque		Models with the highest torque	
Rated voltage [V]	AC/DC 24	AC 230	AC/DC 24	AC 230	AC/DC 24	AC 230
Rated voltage range [V]	AC 19.2...28.8 DC 21.6...28.8	AC 198...264	AC 19.2...28.8 DC 21.6...28.8	AC 198...264	AC 19.2...28.8 DC 21.6...28.8	AC 198...264
Rated voltage frequency AC [Hz]	50/60		50/60		50/60	
Power consumption in rest position [W]	0.8	1.1	1.4	2.1	2	3
Power consumption in operation [W]	2.5	3.5	4	5	7	8.5
Maximum design capacity [VA]	4	6.5	6	10	10	11
Motor torque [Nm]	4		9		18	
Spring torque [Nm]	3		7		12	
Protection class	III	II	III	II	III	II
Ingress protection rating	IP54	IP54	IP54	IP54	IP54	IP54
Auxiliary switches	2 pcs., single-pole, reversible, 1 mA...3(0,5)A, AC 250 V				2 pcs., single-pole, reversible, 1 mA...6(3)A, AC 250 V	
Electric motor connection cable	1 m, 2 x 0.75 mm ² (halogen-free)					
Auxiliary switch connection cable	1 m, 6 x 0.75 mm ² (halogen-free)					
Running time spring	20 seconds at -10...+55 °C < 60 seconds at -30...-10 °C		20 seconds at -10...+55 °C < 60 seconds at -30...-10 °C		16 seconds at +20 °C	
Running time motor	< 60 s/90°		< 60 s/90°		< 120 s/90°	
Response temperature of thermal breaker sensors	Duct sensor 72 °C Outdoor sensor 72 °C					
Service life	Min. 60 000 emergency positions					
Technical maintenance	Not required					

ZERN ELECTRIC ACTUATORS WITH A RETURN SPRING AND A THERMAL BREAKER

Parameters	Basic models		Models with increased torque	
Rated voltage [V]	AC/DC 24	AC 100–240	AC/DC 24	AC 100–240
Rated voltage range [V]	AC/DC 19.2...28.8	AC 85...265	AC/DC 19.2...28.8	AC 85...265
Rated voltage frequency AC [Hz]	50/60		50/60	
Power consumption in rest position [W]	3		3	
Power consumption in operation [W]	5		5	
Motor torque [Nm]	5		8	
Spring torque [Nm]	5		8	
Protection class	III	II	III	II
Ingress protection rating	IP54	IP54	IP54	IP54
Auxiliary switches	2 pcs., single-pole, reversible, 1 mA...3(0,5)A, AC 220 V			
Electric motor connection cable	1 m, 2 x 0.5 mm ² (halogen-free)			
Auxiliary switch connection cable	1 m, 6 x 0.5 mm ² (halogen-free)			
Running time spring	<20 seconds < 60 seconds at -30...-10 °C		<25 seconds < 60 seconds at -30...-10 °C	
Running time motor	< 70 s/95°		< 100 s/95°	
Response temperature of thermal breaker sensors	Duct sensor 72 °C Outdoor sensor 72 °C			

SIEMENS ELECTRIC ACTUATORS WITH A RETURN SPRING AND A THERMAL BREAKER

Parameters	Basic models		Models with increased torque		Models with the highest torque	
Rated voltage [V]	AC 24/ DC 24...48	AC 230	AC 24/ DC 24...48	AC 230	AC 24/ DC 24...48	AC 230
Rated voltage range [V]	AC/DC ±20 %	AC ±15 %	AC/DC ±20 %	AC ±15 %	AC/DC ±20 %	AC ±15 %
Rated voltage frequency AC [Hz]	50/60		50/60		50/60	
Power consumption in rest position [W]	2	3.5	2	3.5	3	4
Power consumption in operation [W]	3.5	4.5	3.5	4.5	5	6
Maximum design capacity [VA]	5	7	5	7	7	8
Motor torque [Nm]	4		9		18	
Spring torque [Nm]	4		7		18	
Protection class	III	II	III	II	III	II
Ingress protection rating	IP54	IP54	IP54	IP54	IP54	IP54
Auxiliary switches	2 pcs., single-pole, reversible, 6(2)A, AC 24...250 V					
Electric motor connection cable	0.9 m, 2 x 0.75 mm ² (halogen-free)					
Auxiliary switch connection cable	0.9 m, 6 x 0.75 mm ² (halogen-free)					
Running time spring	15 seconds < 60 seconds at -30...-10 °C					
Running time motor	90 s/90°					
Response temperature of thermal breaker sensors	Duct sensor 72 °C Outdoor sensor 72 °C					
Service life	10 000 emergency positions					
Technical maintenance	Not required					

Electrical connection

BASIC MODELS BELIMO AND ZERN ELECTRIC ACTUATORS, BELIMO AND ZERN MODELS WITH INCREASED TORQUE

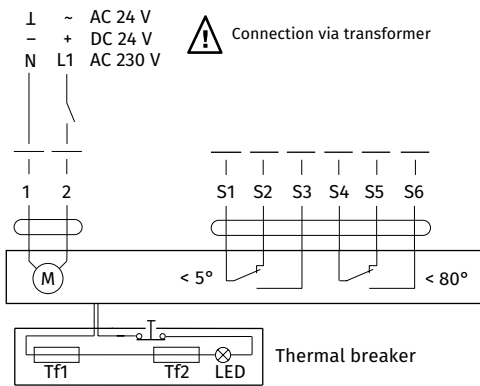

BELIMO ELECTRIC ACTUATORS WITH THE HIGHEST TORQUE, SIEMENS ELECTRIC ACTUATORS

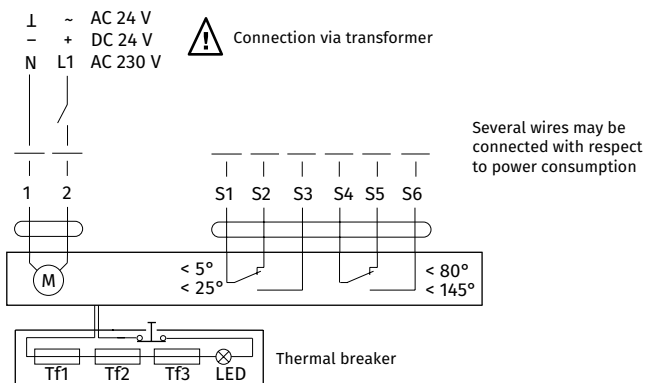

BSK

Fire-resisting dampers

Use

- A fire safety damper prevents the spread of smoke and fire via ventilation and air conditioning system ducts in the event of fire.
- Such units are installed in air ducts located in fire-separation walls and ceilings. The fire resistance rating according to EN 1366-2 is EIS 60 or EIS 120.



Normally open fire-resisting duct damper with a thermal fuse and a return spring

Normally open fire-resisting duct damper with an electric actuator, a return spring and a thermoelectric breaker

Design

- The **BSK** series dampers are made in the general-purpose industrial version with a minimized variety of hardware components using low-alloy galvanized steel. The flap is made of fire-resistant material (vermiculite) with thermoexpansive fireproof sealing.
- The duct design implies two connection ports for integration into a ventilation duct (duct system).

Control and modifications

- Depending on the design variant the **BSK** series dampers are equipped with:

MECHANICAL ACTUATING UNIT WITH A THERMAL FUSE AND A RETURN SPRING

- The fire safety damper remains open in the protective position. The damper is set to the operating position upon the thermal fuse breakdown resulting from a temperature increase. In the event of fire, the fusible element will melt upon the temperature reaching 72 °C and the spring will set the flap to the closed position.

ELECTRIC ACTUATOR WITH A BUILT-IN RETURN SPRING AND A THERMALLY SENSITIVE BREAKER

- Setting the damper to operating position (direct fire contact): remotely, via electric actuator. The damper can be set to the operating or protective position either remotely via a control panel or manually using the manual cocking handle which is always included in the standard delivery set of the electric actuator. In case of the remote control panel failure, the back-up thermal breaker interrupts the power supply to the electric actuator and the return spring sets the damper to the operating position. Emergency damper actuation: The damper flap is set to the protective position automatically (damper unaffected by fire). The electric actuator remains energized at all times. In case of an emergency actuation (direct fire contact): The electric actuator equipped with a return spring is de-energized and the damper flap is set to the operating position by means of the spring energy. In case of a power failure not related to fire and its subsequent restoration at the actuator with a return spring, the damper flap returns to a protective position.

Mounting

- During the fire safety damper installation make sure that the release mechanism and the inspection hole face an easily accessible side of the wall or ceiling. This will ensure convenient control of the thermally sensitive release mechanism and its internals.
- The damper can be embedded into brick or concrete walls with the appropriate fire resistance rating.
- Wooden spreader bars should be used to avoid casing deformation during the installation.

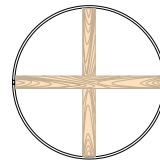

Use of wooden spreader bars during installation

- Upon completing the installation remove the wooden spreader bars.

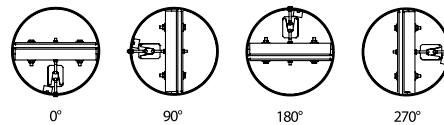

Recommended damper positions

- The damper may not be installed:
 - Into air ducts and on premises rated explosion and fire safety category A and B.
 - Into air ducts of local intakes for flammable and explosive mixtures.
 - Into systems which are do not undergo periodic cleaning pursuant to the established regulations for prevention of flammable deposit buildup.

Designation key

BSK 1 100 PVP24T

Series:
Fire-resisting damper

Fire resistance:
1: 1 hour
2: 2 hours

Rated damper diameter [mm]:
100; 125; 150; 160; 180; 200; 225; 250; 315; 355; 400

Actuator type:
1A: thermal fuse and return spring (manual actuation)
PKP24T: 24 V ZERN electric actuator with a return spring and a thermal breaker
PKP230T: 230 V ZERN electric actuator with a return spring and a thermal breaker
PVP24T: 24 V BELIMO electric actuator with a return spring and a thermal breaker
PVP230T: 230 V BELIMO electric actuator with a return spring and a thermal breaker
PSP24T: 24 V SIEMENS electric actuator with a return spring and a thermal breaker
PSP230T: 230 V SIEMENS actuator with a return spring and a thermal breaker

THE BSK...1A FIRE SAFETY DAMPER WITH A MECHANICAL ACTUATING UNIT, A THERMAL FUSE AND A RETURN SPRING

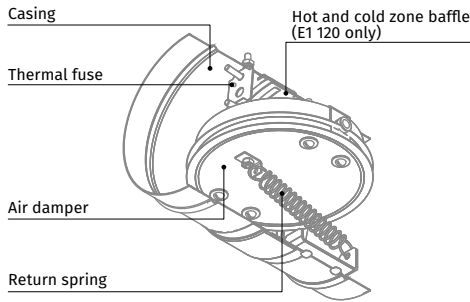

THE BSK...PKP/BSK...PVP/BSK...PSP FIRE SAFETY DAMPER WITH AN ELECTRIC ACTUATOR AND A THERMOELECTRIC BREAKER

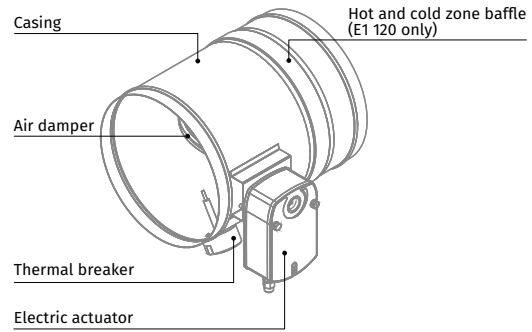

INSTALLATION RECOMMENDATIONS FOR BSK...1A DAMPERS WITH A MECHANICAL ACTUATING UNIT WITH A THERMAL FUSE AND A RETURN SPRING

IN VERTICAL BUILDING STRUCTURES

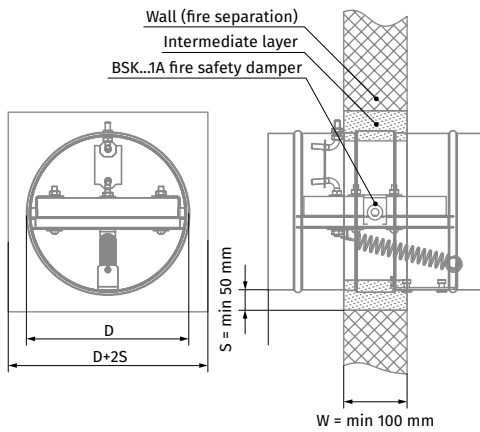

IN HORIZONTAL BUILDING STRUCTURES

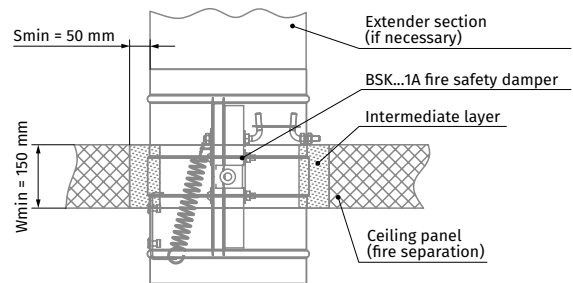

INSTALLATION RECOMMENDATIONS FOR BSK...PKP/BSK...PVP/BSK...PSP FIRE SAFETY DAMPERS WITH ELECTRIC ACTUATOR AND THERMOELECTRIC BREAKER

IN VERTICAL BUILDING STRUCTURES

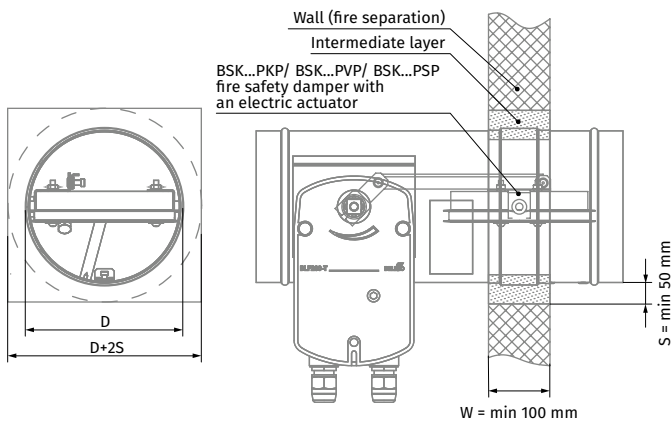

IN HORIZONTAL BUILDING STRUCTURES

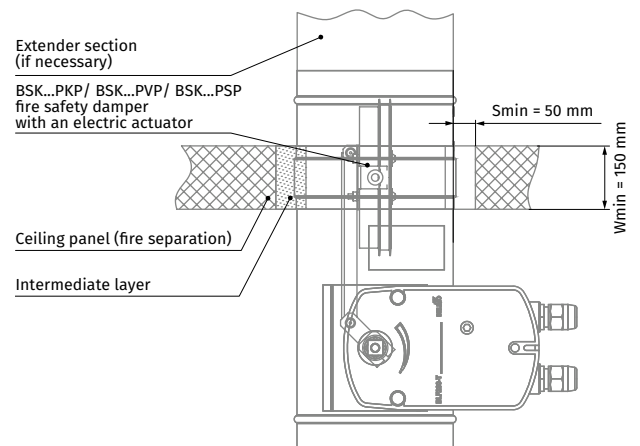

FIRE SAFETY DAMPER WITH A MECHANICAL ACTUATING UNIT, A THERMAL FUSE AND A RETURN SPRING

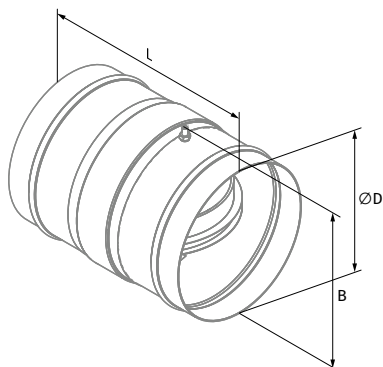

FIRE SAFETY DAMPER WITH AN ELECTRIC ACTUATOR AND A THERMALLY SENSITIVE BREAKER

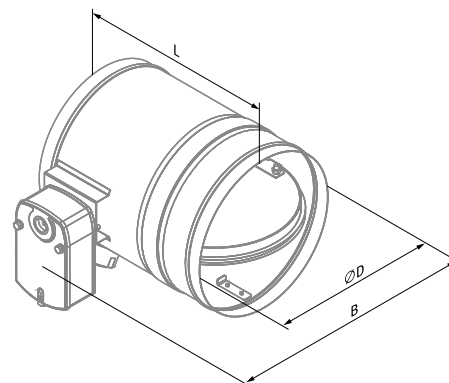

Overall and connecting dimensions

BSK DAMPERS WITH A MECHANICAL ACTUATOR

Modification	Dimensions [mm]			Weight [kg]
	Ø D	L	B	
BSK...100 1A	99	170	112	1
BSK...125 1A	124	170	137	1.2
BSK...150 1A	149	170	162	1.5
BSK...160 1A	159	170	172	1.6
BSK...180 1A	179	170	192	1.8
BSK...200 1A	199	170	212	2
BSK...225 1A	224	170	237	2.2
BSK...250 1A	249	190	262	2.5
BSK...315 1A	314	190	327	3.6
BSK...355 1A	354	190	367	4.4
BSK...400 1A	399	240	412	6

BSK DAMPERS WITH AN ELECTRIC ACTUATOR

Modification	Dimensions [mm]			Weight [kg]
	Ø D	L	B	
BSK...100 PKP(PVP, PSP)	99	300	195	2.9
BSK...125 PKP(PVP, PSP)	124	300	215	3.1
BSK...150 PKP(PVP, PSP)	149	300	245	3.4
BSK...160 PKP(PVP, PSP)	159	300	255	3.5
BSK...180 PKP(PVP, PSP)	179	300	275	3.8
BSK...200 PKP(PVP, PSP)	199	300	295	4
BSK...225 PKP(PVP, PSP)	224	300	325	4.4
BSK...250 PKP(PVP, PSP)	249	310	345	4.7
BSK...315 PKP(PVP, PSP)	314	310	415	6.5
BSK...355 PKP(PVP, PSP)	354	310	455	8.3
BSK...400 PKP(PVP, PSP)	399	310	505	9.9

Technical data

BELIMO ELECTRIC ACTUATORS WITH A RETURN SPRING AND A THERMAL BREAKER

Parameters	Basic models	
Rated voltage [V]	AC/DC 24	AC 230
Rated voltage range [V]	AC 19.2...28.8 DC 21.6...28.8	AC 198...264
Rated voltage frequency AC [Hz]	50/60	
Power consumption in rest position [W]	0.8	1.1
Power consumption in operation [W]	2.5	3.5
Maximum design capacity [VA]	4	6.5
Motor torque [Nm]	4	
Spring torque [Nm]	3	
Protection class	III	II
Ingress protection rating	IP54	IP54
Auxiliary switches	2 pcs., single-pole, reversible, 1 mA...3(0,5)A, AC 250 V	
Electric motor connection cable	1 m, 2 x 0.75 mm ² (halogen-free)	
Auxiliary switch connection cable	1 m, 6 x 0.75 mm ² (halogen-free)	
Running time spring	20 seconds at -10...+55 °C < 60 seconds at -30...-10 °C	
Running time motor	< 60 s/90°	
Response temperature of thermal breaker sensors	Duct sensor 72 °C Outdoor sensor 72 °C	
Service life	Min. 60 000 emergency positions	
Technical maintenance	Not required	

ZERN ELECTRIC ACTUATORS WITH A RETURN SPRING AND A THERMAL BREAKER

Parameters	Basic models	
Rated voltage [V]	AC/DC 24	AC 100-240
Rated voltage range [V]	AC/DC 19.2...28.8	AC 85...265
Rated voltage frequency AC [Hz]	50/60	
Power consumption in rest position [W]	3	
Power consumption in operation [W]	5	
Motor torque [Nm]	5	
Spring torque [Nm]	5	
Protection class	III	II
Ingress protection rating	IP54	IP54
Auxiliary switches	2 pcs., single-pole, reversible, 1 mA...3(0,5)A, AC 220 V	
Electric motor connection cable	1 m, 2 x 0.5 mm ² (halogen-free)	
Auxiliary switch connection cable	1 m, 6 x 0.5 mm ² (halogen-free)	
Running time spring	<20 seconds < 60 seconds at -30...-10 °C	
Running time motor	< 70 s/95°	
Response temperature of thermal breaker sensors	Duct sensor 72 °C Outdoor sensor 72 °C	

SIEMENS ELECTRIC ACTUATORS WITH A RETURN SPRING AND A THERMAL BREAKER

Parameters	Basic models	
Rated voltage [V]	AC 24/DC 24...48	AC 230
Rated voltage range [V]	AC/DC ±20 %	AC ±15 %
Rated voltage frequency AC [Hz]	50/60	
Power consumption in rest position [W]	2	3.5
Power consumption in operation [W]	3.5	4.5
Maximum design capacity [VA]	5	7
Motor torque [Nm]	4	
Spring torque [Nm]	4	
Protection class	III	II
Ingress protection rating	IP54	IP54
Auxiliary switches	2 pcs., single-pole, reversible, 6(2)A, AC 24...250 V	
Electric motor connection cable	0.9 m, 2 x 0.75 mm ² (halogen-free)	
Auxiliary switch connection cable	0.9 m, 6 x 0.75 mm ² (halogen-free)	
Running time spring	15 seconds < 60 seconds at -30...-10 °C	
Running time motor	90 s/90°	
Response temperature of thermal breaker sensors	Duct sensor 72 °C Outdoor sensor 72 °C	
Service life	10 000 emergency positions	
Technical maintenance	Not required	

ACCESSORIES FOR FIRE SAFETY DAMPERS

D-RSK

Smoke exhaust grille for fire safety dampers

Use

- The **RSKE/RSKM** smoke exhaust dampers and the **BSK-1, BSK-2** wall-mounted fire-resisting dampers (1 flange) can be additionally equipped with a smoke exhaust grille.
- The smoke exhaust grille is used to entirely block the external view of the damper internals in the absence of strict requirements to the unit appearance.
- The smoke exhaust grille also doubles as unauthorized access protection for the damper and its actuator. The grille has a single horizontal row of non-adjustable air flow guides fixed at 45°.



Design

- The grille can be made of galvanized steel (Zn), carbon steel with a special coating (M), stainless steel (N) or aluminium (A).

Mounting

- The grille is attached directly to the damper flange by means of self-tapping screws with the louvre shutters facing outwards.

Designation key

Series:
Smoke exhaust grille

Material:
Zn: galvanized steel
M: carbon steel with a special coating
N: stainless steel
A: aluminium

Damper type:
RSKM, RSKE

Working section of the damper: BxH (B – width [mm]; H – height [mm])
Damper flow area width [cm]: 30; 35; 40; 45; 50; 55; 60; 65; 70; 75; 80; 85; 90; 95; 100
Damper flow area height [cm]: 30; 35; 40; 45; 50; 55; 60; 65; 70; 75; 80; 85; 90; 95; 100

D-RSK X - X - X

Overall dimensions [mm]

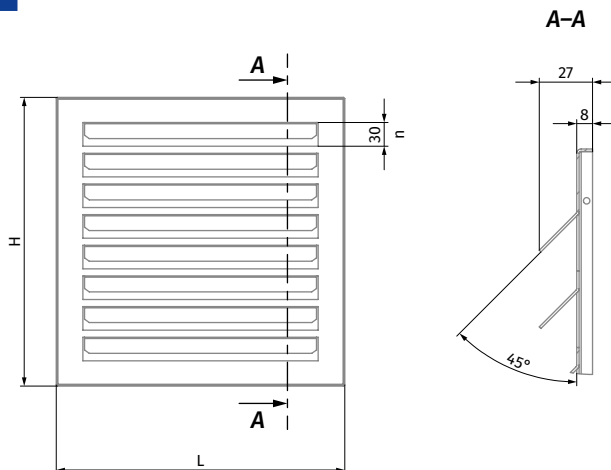
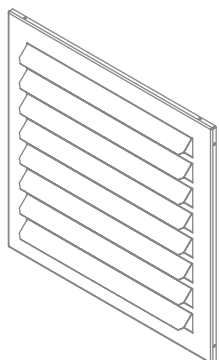

- When ordering smoke exhaust grilles for BSK-1 and BSK-2 dampers, it is necessary to order a grille with the name D-RSK... RSKM...

Model	H	L	n [items]	Cross-sectional area [m ²]	Weight of the galvanized steel grille [kg]
D-RSK 30x30 (for RSKE)	367	367	8	0.059	1.29
D-RSK 35x30 (for RSKE)	367	417	8	0.069	1.46
D-RSK 40x30 (for RSKE)	367	467	8	0.080	1.63
D-RSK 45x30 (for RSKE)	367	517	8	0.090	1.80
D-RSK 50x30 (for RSKE)	367	567	8	0.101	1.97
D-RSK 55x30 (RSKM/RSKE)	367	617	8	0.111	2.14
D-RSK 60x30 (RSKM/RSKE)	367	667	8	0.122	2.32
D-RSK 65x30 (RSKM/RSKE)	367	717	8	0.132	2.49
D-RSK 70x30 (RSKM/RSKE)	367	767	8	0.143	2.66
D-RSK 75x30 (RSKM/RSKE)	367	817	8	0.153	2.83
D-RSK 80x30 (RSKM/RSKE)	367	867	8	0.164	3.00
D-RSK 85x30 (RSKM/RSKE)	367	917	8	0.174	3.17
D-RSK 90x30 (RSKM/RSKE)	367	967	8	0.185	3.34
D-RSK 95x30 (RSKM/RSKE)	367	1017	8	0.195	3.51
D-RSK 100x30 (RSKM/RSKE)	367	1067	8	0.206	3.68
D-RSK 35x35 (for RSKE)	417	417	9	0.079	1.66
D-RSK 40x35 (for RSKE)	417	467	9	0.091	1.85
D-RSK 45x35 (for RSKE)	417	517	9	0.103	2.04
D-RSK 50x35 (for RSKE)	417	567	9	0.115	2.24
D-RSK 55x35 (RSKM/RSKE)	417	617	9	0.127	2.43
D-RSK 60x35 (RSKM/RSKE)	417	667	9	0.139	2.62
D-RSK 65x35 (RSKM/RSKE)	417	717	9	0.151	2.81
D-RSK 70x35 (RSKM/RSKE)	417	767	9	0.163	3.01
D-RSK 75x35 (RSKM/RSKE)	417	817	9	0.175	3.20
D-RSK 80x35 (RSKM/RSKE)	417	867	9	0.187	3.39
D-RSK 85x35 (RSKM/RSKE)	417	917	9	0.199	3.59
D-RSK 90x35 (RSKM/RSKE)	417	967	9	0.211	3.78
D-RSK 95x35 (RSKM/RSKE)	417	1017	9	0.223	3.97
D-RSK 100x35 (RSKM/RSKE)	417	1067	9	0.235	4.17
D-RSK 40x40 (for RSKE)	467	467	10	0.114	2.07
D-RSK 45x40 (for RSKE)	467	517	10	0.129	2.28
D-RSK 50x40 (for RSKE)	467	567	10	0.144	2.50
D-RSK 55x40 (RSKM/RSKE)	467	617	10	0.159	2.71
D-RSK 60x40 (RSKM/RSKE)	467	667	10	0.174	2.93
D-RSK 65x40 (RSKM/RSKE)	467	717	10	0.189	3.14
D-RSK 70x40 (RSKM/RSKE)	467	767	10	0.204	3.36
D-RSK 75x40 (RSKM/RSKE)	467	817	10	0.219	3.57
D-RSK 80x40 (RSKM/RSKE)	467	867	10	0.234	3.79
D-RSK 85x40 (RSKM/RSKE)	467	917	10	0.249	4.01
D-RSK 90x40 (RSKM/RSKE)	467	967	10	0.264	4.22
D-RSK 95x40 (RSKM/RSKE)	467	1017	10	0.279	4.44
D-RSK 100x40 (RSKM/RSKE)	467	1067	10	0.294	4.65
D-RSK 45x45 (for RSKE)	517	517	12	0.142	2.51
D-RSK 50x45 (for RSKE)	517	567	12	0.158	2.75

Model	H	L	n [items]	Cross-sectional area [m ²]	Weight of the galvanized steel grille [kg]
D-RSK 55x45 (RSKM/RSKE)	517	617	12	0.175	2.98
D-RSK 60x45 (RSKM/RSKE)	517	667	12	0.191	3.22
D-RSK 65x45 (RSKM/RSKE)	517	717	12	0.208	3.46
D-RSK 70x45 (RSKM/RSKE)	517	767	12	0.224	3.69
D-RSK 75x45 (RSKM/RSKE)	517	817	12	0.241	3.93
D-RSK 80x45 (RSKM/RSKE)	517	867	12	0.257	4.17
D-RSK 85x45 (RSKM/RSKE)	517	917	12	0.274	4.41
D-RSK 90x45 (RSKM/RSKE)	517	967	12	0.290	4.64
D-RSK 95x45 (RSKM/RSKE)	517	1017	12	0.307	4.88
D-RSK 100x45 (RSKM/RSKE)	517	1067	12	0.323	5.12
D-RSK 50x50 (for RSKE)	567	567	13	0.173	3.01
D-RSK 55x50 (RSKM/RSKE)	567	617	13	0.191	3.27
D-RSK 60x50 (RSKM/RSKE)	567	667	13	0.209	3.53
D-RSK 65x50 (RSKM/RSKE)	567	717	13	0.227	3.79
D-RSK 70x50 (RSKM/RSKE)	567	767	13	0.245	4.05
D-RSK 75x50 (RSKM/RSKE)	567	817	13	0.263	4.31
D-RSK 80x50 (RSKM/RSKE)	567	867	13	0.281	4.57
D-RSK 85x50 (RSKM/RSKE)	567	917	13	0.299	4.82
D-RSK 90x50 (RSKM/RSKE)	567	967	13	0.317	5.08
D-RSK 95x50 (RSKM/RSKE)	567	1017	13	0.335	5.34
D-RSK 100x50 (RSKM/RSKE)	567	1067	13	0.353	5.60
D-RSK 55x55 (RSKM/RSKE)	617	617	14	0.207	3.55
D-RSK 60x55 (RSKM/RSKE)	617	667	14	0.226	3.83
D-RSK 65x55 (RSKM/RSKE)	617	717	14	0.246	4.12
D-RSK 70x55 (RSKM/RSKE)	617	767	14	0.265	4.40
D-RSK 75x55 (RSKM/RSKE)	617	817	14	0.285	4.68
D-RSK 80x55 (RSKM/RSKE)	617	867	14	0.304	4.96
D-RSK 85x55 (RSKM/RSKE)	617	917	14	0.324	5.24
D-RSK 90x55 (RSKM/RSKE)	617	967	14	0.343	5.53
D-RSK 95x55 (RSKM/RSKE)	617	1017	14	0.363	5.81
D-RSK 100x55 (RSKM/RSKE)	617	1067	14	0.382	6.09
D-RSK 60x60 (RSKM/RSKE)	667	667	15	0.244	4.14
D-RSK 65x60 (RSKM/RSKE)	667	717	15	0.265	4.44
D-RSK 70x60 (RSKM/RSKE)	667	767	15	0.286	4.75
D-RSK 75x60 (RSKM/RSKE)	667	817	15	0.307	5.05
D-RSK 80x60 (RSKM/RSKE)	667	867	15	0.328	5.36
D-RSK 85x60 (RSKM/RSKE)	667	917	15	0.349	5.66
D-RSK 90x60 (RSKM/RSKE)	667	967	15	0.370	5.97
D-RSK 95x60 (RSKM/RSKE)	667	1017	15	0.391	6.27
D-RSK 100x60 (RSKM/RSKE)	667	1067	15	0.412	6.58
D-RSK 65x65 (RSKM/RSKE)	717	717	16	0.284	4.77
D-RSK 70x65 (RSKM/RSKE)	717	767	16	0.306	5.10
D-RSK 75x65 (RSKM/RSKE)	717	817	16	0.329	5.43
D-RSK 80x65 (RSKM/RSKE)	717	867	16	0.351	5.75
D-RSK 85x65 (RSKM/RSKE)	717	917	16	0.374	6.08
D-RSK 90x65 (RSKM/RSKE)	717	967	16	0.396	6.41
D-RSK 95x65 (RSKM/RSKE)	717	1017	16	0.419	6.74
D-RSK 100x65 (RSKM/RSKE)	717	1067	16	0.441	7.06
D-RSK 70x70 (RSKM/RSKE)	767	767	18	0.347	5.44
D-RSK 75x70 (RSKM/RSKE)	767	817	18	0.372	5.78
D-RSK 80x70 (RSKM/RSKE)	767	867	18	0.398	6.13
D-RSK 85x70 (RSKM/RSKE)	767	917	18	0.423	6.48
D-RSK 90x70 (RSKM/RSKE)	767	967	18	0.449	6.83
D-RSK 95x70 (RSKM/RSKE)	767	1017	18	0.474	7.18
D-RSK 100x70 (RSKM/RSKE)	767	1067	18	0.500	7.53
D-RSK 75x75 (RSKM/RSKE)	817	817	19	0.394	6.16
D-RSK 80x75 (RSKM/RSKE)	817	867	19	0.421	6.53
D-RSK 85x75 (RSKM/RSKE)	817	917	19	0.448	6.90
D-RSK 90x75 (RSKM/RSKE)	817	967	19	0.475	7.27
D-RSK 95x75 (RSKM/RSKE)	817	1017	19	0.502	7.64
D-RSK 100x75 (RSKM/RSKE)	817	1067	19	0.529	8.01

Model	H	L	n [items]	Cross-sectional area [m ²]	Weight of the galvanized steel grille [kg]
D-RSK 80x80 (RSKM/RSKE)	867	867	20	0.445	6.93
D-RSK 85x80 (RSKM/RSKE)	867	917	20	0.473	7.32
D-RSK 90x80 (RSKM/RSKE)	867	967	20	0.502	7.71
D-RSK 95x80 (RSKM/RSKE)	867	1017	20	0.530	8.11
D-RSK 100x80 (RSKM/RSKE)	867	1067	20	0.559	8.50
D-RSK 85x85 (RSKM/RSKE)	917	917	21	0.498	7.74
D-RSK 90x85 (RSKM/RSKE)	917	967	21	0.528	8.16
D-RSK 95x85 (RSKM/RSKE)	917	1017	21	0.558	8.57
D-RSK 100x85 (RSKM/RSKE)	917	1067	21	0.588	8.99
D-RSK 90x90 (RSKM/RSKE)	967	967	22	0.554	8.60
D-RSK 95x90 (RSKM/RSKE)	967	1017	22	0.586	9.04
D-RSK 100x90 (RSKM/RSKE)	967	1067	22	0.617	9.47
D-RSK 95x95 (RSKM/RSKE)	1017	1017	23	0.614	9.50
D-RSK 100x95 (RSKM/RSKE)	1017	1067	23	0.647	9.96
D-RSK 100x100 (RSKM/RSKE)	1067	1067	24	0.676	10.45
D-RSK 30x30 (for RSKM)	347	347	8	0.059	1.15
D-RSK 35x30 (for RSKM)	347	397	8	0.069	1.31
D-RSK 40x30 (for RSKM)	347	447	8	0.080	1.48
D-RSK 45x30 (for RSKM)	347	497	8	0.090	1.64
D-RSK 50x30 (for RSKM)	347	547	8	0.101	1.80
D-RSK 35x35 (for RSKM)	397	397	9	0.079	1.50
D-RSK 40x35 (for RSKM)	397	447	9	0.091	1.68
D-RSK 45x35 (for RSKM)	397	497	9	0.103	1.87
D-RSK 50x35 (for RSKM)	397	547	9	0.115	2.05
D-RSK 40x40 (for RSKM)	447	447	10	0.114	1.89
D-RSK 45x40 (for RSKM)	447	497	10	0.129	2.09
D-RSK 50x40 (for RSKM)	447	547	10	0.144	2.30
D-RSK 45x45 (for RSKM)	497	497	11	0.142	2.32
D-RSK 50x45 (for RSKM)	497	547	11	0.158	2.55
D-RSK 50x50 (for RSKM)	547	547	12	0.173	2.79

The BSK-1, BSK-2 fire-resisting duct dampers (2 flanges) for completing with an D-RSK grille can be ordered separately.

S-RSK

Protective grille for fire safety dampers

Use

- The **RSKE/RSKM** smoke exhaust dampers and the **BSK-1, BSK-2** wall-mounted fire-resisting dampers (1 flange) can be additionally equipped with a protective grille **S-RSK**.
- The protective grille serves for protection against unauthorized access to the damper and its actuating mechanism.



Design

- The grille is only made from galvanized steel.

Mounting

- The grille is attached directly to the damper flange by means of self-tapping screws.

Designation key

Series:
Protective grille

S-RSK X

Working section of the damper: BxH (B – width [mm]; H – height [mm])
Damper flow area width [cm]: 30; 35; 40; 45; 50; 55; 60; 65; 70; 75; 80; 85; 90; 95; 100
Damper flow area height [cm]: 30; 35; 40; 45; 50; 55; 60; 65; 70; 75; 80; 85; 90; 95; 100

Overall dimensions [mm]

Model	H	L	Cross-sectional area [m²]	Weight [kg]
S-RSK 30x30	340	340	0.072	0.75
S-RSK 35x30	340	390	0.090	0.86
S-RSK 35x35	390	390	0.103	0.91
S-RSK 40x30	340	440	0.103	0.91
S-RSK 40x35	390	440	0.120	0.94
S-RSK 40x40	440	440	0.141	0.99
S-RSK 45x30	340	490	0.120	0.94
S-RSK 45x35	390	490	0.141	0.99
S-RSK 45x40	440	490	0.159	1.02
S-RSK 45x45	490	490	0.178	1.12
S-RSK 50x30	340	540	0.141	0.99
S-RSK 50x35	390	540	0.159	1.02
S-RSK 50x40	440	540	0.178	1.12
S-RSK 50x45	490	540	0.190	1.20
S-RSK 50x50	540	540	0.210	1.22
S-RSK 55x30	360	610	0.159	1.02
S-RSK 55x35	410	610	0.178	1.12
S-RSK 55x40	460	610	0.190	1.20
S-RSK 55x45	510	610	0.210	1.22

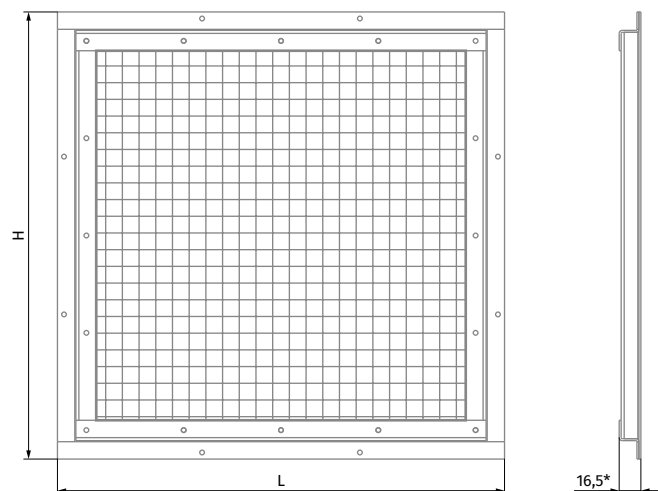

Model	H	L	Cross-sectional area [m ²]	Weight [kg]
S-RSK 55x50	560	610	0.269	1.30
S-RSK 55x55	610	610	0.293	1.37
S-RSK 60x30	360	660	0.178	1.12
S-RSK 60x35	410	660	0.190	1.20
S-RSK 60x40	460	660	0.210	1.22
S-RSK 60x45	510	660	0.269	1.30
S-RSK 60x50	560	660	0.293	1.37
S-RSK 60x55	610	660	0.305	1.42
S-RSK 60x60	660	660	0.321	1.45
S-RSK 65x30	360	710	0.190	1.30
S-RSK 65x35	410	710	0.210	1.22
S-RSK 65x40	460	710	0.269	1.30
S-RSK 65x45	510	710	0.293	1.37
S-RSK 65x50	560	710	0.305	1.42
S-RSK 65x55	610	710	0.321	1.45
S-RSK 65x60	660	710	0.340	1.48
S-RSK 65x65	710	710	0.392	1.51
S-RSK 70x30	360	760	0.210	1.22
S-RSK 70x35	410	760	0.269	1.30
S-RSK 70x40	460	760	0.293	1.37
S-RSK 70x45	510	760	0.305	1.42
S-RSK 70x50	560	760	0.321	1.45
S-RSK 70x55	610	760	0.340	1.48
S-RSK 70x60	660	760	0.392	1.51
S-RSK 70x65	710	760	0.411	1.56
S-RSK 70x70	760	760	0.446	1.59
S-RSK 75x30	360	810	0.269	1.30
S-RSK 75x35	410	810	0.293	1.37
S-RSK 75x40	460	810	0.305	1.42
S-RSK 75x45	510	810	0.321	1.45
S-RSK 75x50	560	810	0.340	1.48
S-RSK 75x55	610	810	0.392	1.51
S-RSK 75x60	660	810	0.411	1.56
S-RSK 75x65	710	810	0.446	1.59
S-RSK 75x70	760	810	0.495	1.65
S-RSK 75x75	810	810	0.507	1.70
S-RSK 80x30	360	860	0.293	1.37
S-RSK 80x35	410	860	0.305	1.42
S-RSK 80x40	460	860	0.321	1.45
S-RSK 80x45	510	860	0.340	1.48
S-RSK 80x50	560	860	0.392	1.51
S-RSK 80x55	610	860	0.411	1.56
S-RSK 80x60	660	860	0.446	1.59
S-RSK 80x65	710	860	0.495	1.65
S-RSK 80x70	760	860	0.507	1.70
S-RSK 80x75	810	860	0.582	1.74
S-RSK 80x80	860	860	0.614	1.78
S-RSK 85x30	360	910	0.305	1.46
S-RSK 85x35	410	910	0.321	1.45
S-RSK 85x40	460	910	0.340	1.48
S-RSK 85x45	510	910	0.392	1.51

Model	H	L	Cross-sectional area [m ²]	Weight [kg]
S-RSK 85x50	560	910	0.411	1.56
S-RSK 85x55	610	910	0.446	1.59
S-RSK 85x60	660	910	0.495	1.65
S-RSK 85x65	710	910	0.507	1.70
S-RSK 85x70	760	910	0.582	1.74
S-RSK 85x75	810	910	0.614	1.78
S-RSK 85x80	860	910	0.639	1.84
S-RSK 85x85	910	910	0.694	1.90
S-RSK 90x30	360	960	0.321	1.45
S-RSK 90x35	410	960	0.340	1.48
S-RSK 90x40	460	960	0.392	1.51
S-RSK 90x45	510	960	0.411	1.56
S-RSK 90x50	560	960	0.446	1.59
S-RSK 90x55	610	960	0.495	1.65
S-RSK 90x60	660	960	0.507	1.70
S-RSK 90x65	710	960	0.582	1.74
S-RSK 90x70	760	960	0.614	1.78
S-RSK 90x75	810	960	0.639	1.84
S-RSK 90x80	860	960	0.694	1.90
S-RSK 90x85	910	960	0.715	1.93
S-RSK 90x90	960	960	0.769	1.98
S-RSK 95x30	360	1010	0.340	1.48
S-RSK 95x35	410	1010	0.392	1.51
S-RSK 95x40	460	1010	0.411	1.56
S-RSK 95x45	510	1010	0.446	1.59
S-RSK 95x50	560	1010	0.495	1.65
S-RSK 95x55	610	1010	0.507	1.70
S-RSK 95x60	660	1010	0.582	1.74
S-RSK 95x65	710	1010	0.614	1.78
S-RSK 95x70	760	1010	0.639	1.84
S-RSK 95x75	810	1010	0.694	1.90
S-RSK 95x80	860	1010	0.715	1.93
S-RSK 95x85	910	1010	0.769	1.98
S-RSK 95x90	960	1010	0.811	2.05
S-RSK 95x95	1010	1010	0.874	2.10
S-RSK 100x30	360	1060	0.392	1.51
S-RSK 100x35	410	1060	0.411	1.56
S-RSK 100x40	460	1060	0.446	1.59
S-RSK 100x45	510	1060	0.495	1.65
S-RSK 100x50	560	1060	0.507	1.70
S-RSK 100x55	610	1060	0.582	1.74
S-RSK 100x60	660	1060	0.614	1.78
S-RSK 100x65	710	1060	0.639	1.84
S-RSK 100x70	760	1060	0.694	1.90
S-RSK 100x75	810	1060	0.715	1.93
S-RSK 100x80	860	1060	0.769	1.98
S-RSK 100x85	910	1060	0.811	2.05
S-RSK 100x90	960	1060	0.874	2.10
S-RSK 100x95	1010	1060	0.913	2.17
S-RSK 100x100	1060	1060	0.945	2.21

The BSK-1, BSK-2 fire-resisting duct dampers (2 flanges) for completing with an S-RSK grille can be ordered separately.

MR RSKE/RSKM

Mounting frame for fire safety dampers

Use

- The **RSKE/RSKM** smoke exhaust dampers can be additionally equipped with a mounting frame.
- The mounting frame eases the installation of the damper in the wall opening, creating additional rigidity and preventing deformation of the damper during installation.

Designation key

Series:
Mounting frame

Working section of the damper: BxH (B – width [mm]; H – height [mm])
 Damper flow area width [cm]: 55; 60; 65; 70; 75; 80; 85; 90; 95; 100
 Damper flow area height [cm]: 30; 35; 40; 45; 50; 55; 60; 65; 70; 75; 80; 85; 90; 95; 100

MR RSKE/RSKM X

Overall dimensions [mm]

Model	H	H1	H2	H3	L	L1	L2	L3	Weight [kg]
MR RSKE/RSKM 55x30	317	345	370	330.6	567	580	620	580.6	2.97
MR RSKE/RSKM 60x30	317	345	370	330.6	617	630	670	630.6	3.13
MR RSKE/RSKM 65x30	317	345	370	330.6	667	680	720	680.6	3.29
MR RSKE/RSKM 70x30	317	345	370	330.6	717	730	770	730.6	3.45
MR RSKE/RSKM 75x30	317	345	370	330.6	767	780	820	780.6	3.61
MR RSKE/RSKM 80x30	317	345	370	330.6	817	830	870	830.6	3.77
MR RSKE/RSKM 85x30	317	345	370	330.6	867	880	920	880.6	3.93
MR RSKE/RSKM 90x30	317	345	370	330.6	917	930	970	930.6	4.09
MR RSKE/RSKM 95x30	317	345	370	330.6	967	980	1020	980.6	4.25
MR RSKE/RSKM 100x30	317	345	370	330.6	1017	1030	1070	1030.6	4.41
MR RSKE/RSKM 55x35	367	395	420	380.6	567	580	620	580.6	3.13
MR RSKE/RSKM 60x35	367	395	420	380.6	617	630	670	630.6	3.29
MR RSKE/RSKM 65x35	367	395	420	380.6	667	680	720	680.6	3.45
MR RSKE/RSKM 70x35	367	395	420	380.6	717	730	770	730.6	3.61
MR RSKE/RSKM 75x35	367	395	420	380.6	767	780	820	780.6	3.77
MR RSKE/RSKM 80x35	367	395	420	380.6	817	830	870	830.6	3.93
MR RSKE/RSKM 85x35	367	395	420	380.6	867	880	920	880.6	4.09
MR RSKE/RSKM 90x35	367	395	420	380.6	917	930	970	930.6	4.25
MR RSKE/RSKM 95x35	367	395	420	380.6	967	980	1020	980.6	4.41
MR RSKE/RSKM 100x35	367	395	420	380.6	1017	1030	1070	1030.6	4.57
MR RSKE/RSKM 55x40	417	445	470	430.6	567	580	620	580.6	3.29
MR RSKE/RSKM 60x40	417	445	470	430.6	617	630	670	630.6	3.45
MR RSKE/RSKM 65x40	417	445	470	430.6	667	680	720	680.6	3.61
MR RSKE/RSKM 70x40	417	445	470	430.6	717	730	770	730.6	3.77
MR RSKE/RSKM 75x40	417	445	470	430.6	767	780	820	780.6	3.93
MR RSKE/RSKM 80x40	417	445	470	430.6	817	830	870	830.6	4.09
MR RSKE/RSKM 85x40	417	445	470	430.6	867	880	920	880.6	4.25
MR RSKE/RSKM 90x40	417	445	470	430.6	917	930	970	930.6	4.41
MR RSKE/RSKM 95x40	417	445	470	430.6	967	980	1020	980.6	4.57
MR RSKE/RSKM 100x40	417	445	470	430.6	1017	1030	1070	1030.6	4.73
MR RSKE/RSKM 55x45	467	495	520	480.6	567	580	620	580.6	3.45
MR RSKE/RSKM 60x45	467	495	520	480.6	617	630	670	630.6	3.61

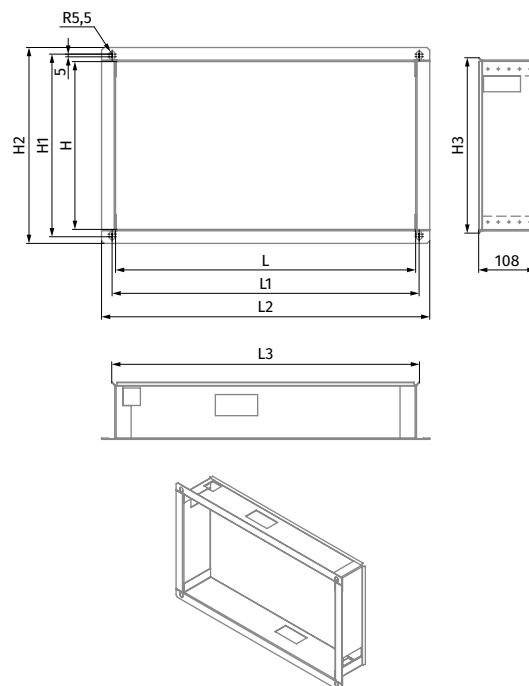

Model	H	H1	H2	H3	L	L1	L2	L3	Weight [kg]
MR RSKE/RSKM 65x45	467	495	520	480.6	667	680	720	680.6	3.77
MR RSKE/RSKM 70x45	467	495	520	480.6	717	730	770	730.6	3.93
MR RSKE/RSKM 75x45	467	495	520	480.6	767	780	820	780.6	4.09
MR RSKE/RSKM 80x45	467	495	520	480.6	817	830	870	830.6	4.25
MR RSKE/RSKM 85x45	467	495	520	480.6	867	880	920	880.6	4.41
MR RSKE/RSKM 90x45	467	495	520	480.6	917	930	970	930.6	4.57
MR RSKE/RSKM 95x45	467	495	520	480.6	967	980	1020	980.6	4.73
MR RSKE/RSKM 100x45	467	495	520	480.6	1017	1030	1070	1030.6	4.89
MR RSKE/RSKM 55x50	517	545	570	530.6	567	580	620	580.6	3.61
MR RSKE/RSKM 60x50	517	545	570	530.6	617	630	670	630.6	3.77
MR RSKE/RSKM 65x50	517	545	570	530.6	667	680	720	680.6	3.93
MR RSKE/RSKM 70x50	517	545	570	530.6	717	730	770	730.6	4.09
MR RSKE/RSKM 75x50	517	545	570	530.6	767	780	820	780.6	4.25
MR RSKE/RSKM 80x50	517	545	570	530.6	817	830	870	830.6	4.41
MR RSKE/RSKM 85x50	517	545	570	530.6	867	880	920	880.6	4.57
MR RSKE/RSKM 90x50	517	545	570	530.6	917	930	970	930.6	4.73
MR RSKE/RSKM 95x50	517	545	570	530.6	967	980	1020	980.6	4.89
MR RSKE/RSKM 100x50	517	545	570	530.6	1017	1030	1070	1030.6	5.05
MR RSKE/RSKM 55x55	567	595	620	580.6	567	580	620	580.6	3.77
MR RSKE/RSKM 60x55	567	595	620	580.6	617	630	670	630.6	3.93
MR RSKE/RSKM 65x55	567	595	620	580.6	667	680	720	680.6	4.09
MR RSKE/RSKM 70x55	567	595	620	580.6	717	730	770	730.6	4.25
MR RSKE/RSKM 75x55	567	595	620	580.6	767	780	820	780.6	4.41
MR RSKE/RSKM 80x55	567	595	620	580.6	817	830	870	830.6	4.57
MR RSKE/RSKM 85x55	567	595	620	580.6	867	880	920	880.6	4.73
MR RSKE/RSKM 90x55	567	595	620	580.6	917	930	970	930.6	4.89
MR RSKE/RSKM 95x55	567	595	620	580.6	967	980	1020	980.6	5.05
MR RSKE/RSKM 100x55	567	595	620	580.6	1017	1030	1070	1030.6	5.21
MR RSKE/RSKM 60x60	617	645	670	630.6	617	630	670	630.6	4.09
MR RSKE/RSKM 65x60	617	645	670	630.6	667	680	720	680.6	4.25
MR RSKE/RSKM 70x60	617	645	670	630.6	717	730	770	730.6	4.41
MR RSKE/RSKM 75x60	617	645	670	630.6	767	780	820	780.6	4.57
MR RSKE/RSKM 80x60	617	645	670	630.6	817	830	870	830.6	4.73
MR RSKE/RSKM 85x60	617	645	670	630.6	867	880	920	880.6	4.89
MR RSKE/RSKM 90x60	617	645	670	630.6	917	930	970	930.6	5.05
MR RSKE/RSKM 95x60	617	645	670	630.6	967	980	1020	980.6	5.21
MR RSKE/RSKM 100x60	617	645	670	630.6	1017	1030	1070	1030.6	5.37
MR RSKE/RSKM 65x65	667	695	720	680.6	667	680	720	680.6	4.41
MR RSKE/RSKM 70x65	667	695	720	680.6	717	730	770	730.6	4.57
MR RSKE/RSKM 75x65	667	695	720	680.6	767	780	820	780.6	4.73
MR RSKE/RSKM 80x65	667	695	720	680.6	817	830	870	830.6	4.89
MR RSKE/RSKM 85x65	667	695	720	680.6	867	880	920	880.6	5.05
MR RSKE/RSKM 90x65	667	695	720	680.6	917	930	970	930.6	5.21
MR RSKE/RSKM 95x65	667	695	720	680.6	967	980	1020	980.6	5.37
MR RSKE/RSKM 100x65	667	695	720	680.6	1017	1030	1070	1030.6	5.53
MR RSKE/RSKM 70x70	717	745	770	730.6	717	730	770	730.6	4.73
MR RSKE/RSKM 75x70	717	745	770	730.6	767	780	820	780.6	4.89
MR RSKE/RSKM 80x70	717	745	770	730.6	817	830	870	830.6	5.05
MR RSKE/RSKM 85x70	717	745	770	730.6	867	880	920	880.6	5.21
MR RSKE/RSKM 90x70	717	745	770	730.6	917	930	970	930.6	5.37
MR RSKE/RSKM 95x70	717	745	770	730.6	967	980	1020	980.6	5.53
MR RSKE/RSKM 100x70	717	745	770	730.6	1017	1030	1070	1030.6	5.69
MR RSKE/RSKM 75x75	767	795	820	780.6	767	780	820	780.6	5.05
MR RSKE/RSKM 80x75	767	795	820	780.6	817	830	870	830.6	5.21
MR RSKE/RSKM 85x75	767	795	820	780.6	867	880	920	880.6	5.37
MR RSKE/RSKM 90x75	767	795	820	780.6	917	930	970	930.6	5.53
MR RSKE/RSKM 95x75	767	795	820	780.6	967	980	1020	980.6	5.69
MR RSKE/RSKM 100x75	767	795	820	780.6	1017	1030	1070	1030.6	5.85
MR RSKE/RSKM 80x80	817	845	870	830.6	817	830	870	830.6	5.37
MR RSKE/RSKM 85x80	817	845	870	830.6	867	880	920	880.6	5.53
MR RSKE/RSKM 90x80	817	845	870	830.6	917	930	970	930.6	5.69
MR RSKE/RSKM 95x80	817	845	870	830.6	967	980	1020	980.6	5.85
MR RSKE/RSKM 100x80	817	845	870	830.6	1017	1030	1070	1030.6	6.01
MR RSKE/RSKM 85x85	867	895	920	880.6	867	880	920	880.6	5.69
MR RSKE/RSKM 90x85	867	895	920	880.6	917	930	970	930.6	5.85
MR RSKE/RSKM 95x85	867	895	920	880.6	967	980	1020	980.6	6.01
MR RSKE/RSKM 100x85	867	895	920	880.6	1017	1030	1070	1030.6	6.17
MR RSKE/RSKM 90x90	917	945	970	930.6	917	930	970	930.6	6.01
MR RSKE/RSKM 95x90	917	945	970	930.6	967	980	1020	980.6	6.17
MR RSKE/RSKM 100x90	917	945	970	930.6	1017	1030	1070	1030.6	6.33
MR RSKE/RSKM 95x95	967	995	1020	980.6	967	980	1020	980.6	6.33
MR RSKE/RSKM 100x95	967	995	1020	980.6	1017	1030	1070	1030.6	6.49
MR RSKE/RSKM 100x100	1017	1045	1070	1030.6	1017	1030	1070	1030.6	6.65

Note: MR RSKE/RSKM frames not indicated in the table can be produced on request.

Mounting

- The damper is attached directly to the flange of the mounting frame by means of self-tapping screws.

FRAME MOUNTING METHODS

Sealing of the damper with an MR RSKE/RSKM mounting frame in the wall opening

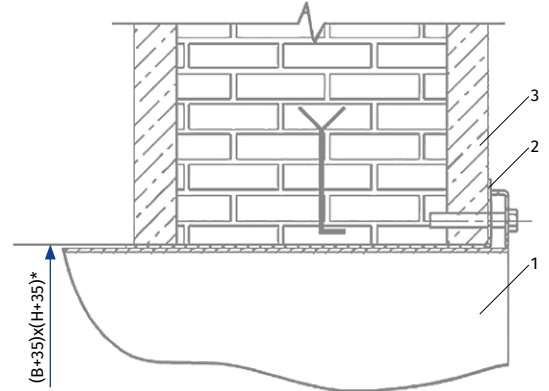

- 1 - damper
 - 2 - mounting frame
 - 3 - wall overlap, where
- B [mm] H [mm] – working section of the damper

*dimensions of the wall opening for the frame

SRFS

Aluminium decorative grille

Use

- For supply and exhaust ventilation, heating and air conditioning systems in industrial, commercial and domestic premises.



Design

- Made of high quality extruded aluminium profile.
- The polymer or anodized coating of the grille provides resistance to adverse weather conditions.
- Grilles with special dimensions can be manufactured upon request.
- Grilles from 450 mm in size are produced with an additional partition to provide rigidity (ONFS series).

Modifications

- Can be equipped with an adapter (A).
- Can be equipped with special springs (P) for quick installation.
- The unit can be equipped with a decorative grille made of aluminium for a more aesthetic appearance.
- The grille has a single horizontal row of non-adjustable air flow guides fixed at 45°.
- The grille is polymer coated and anodised for extra protection against the weather elements.
- To enable the decorative grille installation, the damper must be embedded at least 40 mm deep into the wall as measured from the wall face to the damper flange.

NOTE:

- While selecting the aluminium decorative grille mind the wall opening dimensions.

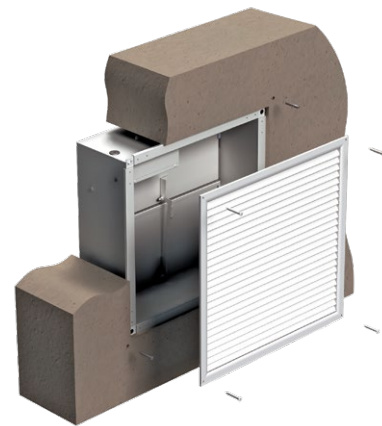

Designation key

Series:
Aluminium decorative grille

Opening dimensions: LxH (L – length [mm]; H – height [mm])
Length [cm]: 10; 15; 20; 25; 30; 35; 40; 45; 50; 60; 70; 80; 90; 100
Height [cm]: 10; 15; 20; 25; 30; 35; 40; 45; 50; 60; 70; 80; 90; 100

Grille fastening:
P: spring

Modifications:
_: no
A: adapter

Grille coating:
_: white colour
***colour*:** according to RAL
An: anodized
Zn: galvanized steel

SRFS X X X X

Pressure drop and sound power level

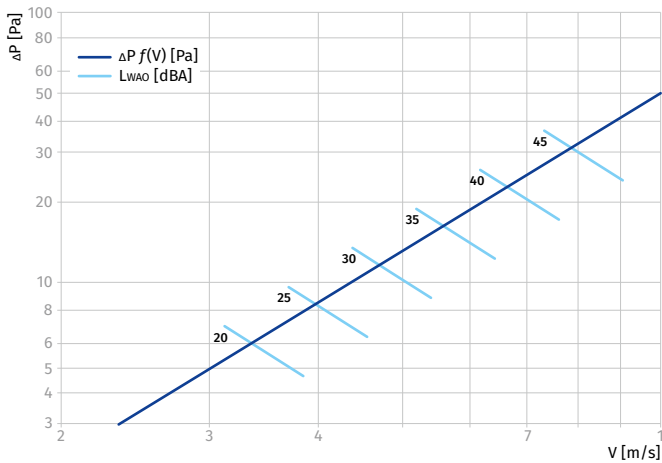

Calculation formula	Correction factor K							
$LWA = LWA0 \times K$	Scs [m ²]	0.005	0.01	0.02	0.03	0.05	0.07	1
	K [dBA]	-13	-9	-6	-4.5	-3	-1.5	0

Designation key:
 ΔP – pressure drop [Pa]
 LWA – sound power level [dBA]
 LWA0 – sound power level for cross-sectional area of 0.1 m² [dBA]
 K – correction factor for sound power level depending on cross-sectional area [dBA]
 Scs – cross-sectional area [m²]
 V – design speed [m/s]

Overall and mounting dimensions

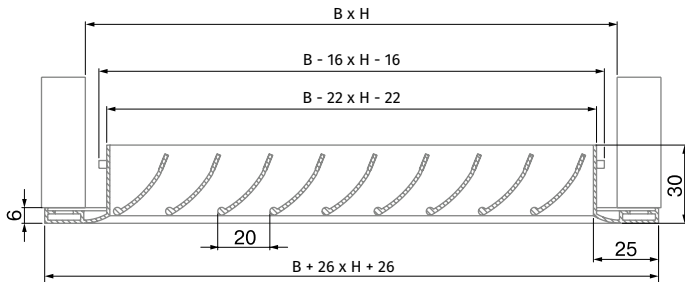

AIR FLOW DISTRIBUTION



Deflection angle of air flow guides – 45°

Cross-section dimensions and area [m²]

Height H [mm]	Length L [mm]													
	100	150	200	250	300	350	400	450	500	600	700	800	900	1000
100	0.004	0.007	0.010	0.012	0.015	0.018	0.021	0.024	0.027	0.033	0.039	0.045	0.051	0.057
150	0.070	0.010	0.015	0.018	0.023	0.027	0.031	0.035	0.039	0.047	0.055	0.064	0.072	0.080
200	0.010	0.015	0.021	0.026	0.033	0.038	0.045	0.051	0.058	0.070	0.081	0.093	0.105	0.115
250	0.012	0.018	0.026	0.032	0.041	0.047	0.055	0.062	0.070	0.084	0.098	0.106	0.113	0.128
300	0.015	0.023	0.033	0.041	0.051	0.059	0.069	0.077	0.086	0.096	0.115	0.132	0.149	0.168
350	0.017	0.026	0.038	0.047	0.059	0.068	0.080	0.090	0.099	0.111	0.132	0.151	0.170	0.193
400	0.020	0.030	0.044	0.054	0.069	0.079	0.093	0.103	0.117	0.142	0.166	0.189	0.212	0.237
450	0.023	0.035	0.051	0.062	0.080	0.090	0.107	0.117	0.131	0.160	0.186	0.214	0.239	0.265
500	0.026	0.039	0.056	0.070	0.089	0.100	0.119	0.130	0.145	0.178	0.206	0.238	0.265	0.293
600	0.031	0.047	0.067	0.084	0.105	0.121	0.142	0.158	0.173	0.214	0.246	0.287	0.318	0.349
700	0.036	0.055	0.078	0.094	0.124	0.145	0.170	0.184	0.203	0.251	0.288	0.336	0.372	0.408
800	0.042	0.063	0.090	0.112	0.141	0.163	0.190	0.211	0.232	0.288	0.330	0.385	0.426	0.467
900	0.048	0.072	0.103	0.129	0.160	0.185	0.228	0.238	0.262	0.325	0.372	0.435	0.481	0.527
1000	0.053	0.079	0.113	0.141	0.177	0.204	0.239	0.266	0.292	0.361	0.414	0.484	0.536	0.587

Blauberg Ventilatoren GmbH
Aidenbachstr. 52
D-81379 Munich

info@blaubergventilatoren.de
www.blaubergventilatoren.de

Technical changes reserved.
Illustrations and texts are non-binding.