



SMOKE EXTRACTION VENTILATION

- Roof-mounted smoke extraction fans
- Axial smoke extraction fans
- Smoke extraction fans for parking
- Fire safety dampers
- Frequency converters

CONTENTS

SMOKE EXTRACTION SOLUTIONS

Smoke extraction systems of buildings	2
Smoke extraction for underground parking	6

ROOF-MOUNTED SMOKE EXTRACTION FANS

Roof-mounted centrifugal smoke extraction fans Tower-SV / Tower-SH	12
--	----

AXIAL SMOKE EXTRACTION FANS

Complete solutions for axial fans	24
Medium pressure axial fans Axis-P	26
Axial smoke extraction fans Axis-FP	50
Fan accessories selection table	118

SMOKE EXTRACTION FANS FOR PARKING

Jet axial fans Axis-Jet	128
Impulse centrifugal fans Centro-Jet	132

FIRE SAFETY DAMPERS

Multi-purpose fire safety smoke dampers RSKE / RSKM	136
Fire-resisting dampers BSK1	150
Fire-resisting dampers BSK2	158
Fire-resisting dampers BSK	168
Smoke exhaust grille D-RSK for fire safety dampers	174
Protective grille S-RSK for fire safety dampers	178
Mounting frame MR RSKE/RSKM for fire safety dampers	180
Aluminium decorative grille SRFS	182

FREQUENCY CONVERTERS

Operation of fans with frequency converters	186
Frequency converters Micro Drive FC-51	187
Frequency converters Basic Drive FC-101	188

SMOKE EXTRACTION SYSTEMS OF BUILDINGS

Smoke control is a complex process involving smoke extraction and fresh air supply by the supply and exhaust ventilation system of buildings in order to ensure safe evacuation of people in case of a fire in any of the spaces.

The smoke control system of a building or structure must ensure protection of people along the evacuation paths from the fire hazards during the time required for the personnel evacuation procedure or the entire period of fire development and control by means of extracting the combustion and thermal decomposition products and/or preventing their spreading. A smoke control system is an integral element of a utility system design including all kinds of high-rise buildings, shopping and office centres, hospital facilities, production and storage spaces etc. as well as underground structures.

According to conclusive evidence the majority of mortalities in a fire are caused by poisoning from carbon monoxide and other combustion products. Carbon monoxide is one of the most toxic smoke components. It is carbon monoxide poisoning that accounts for 80 % of the fire accident causes. Fires in closed spaces where oxygen supply is limited are especially prone to intensive carbon monoxide generation. Carbon monoxide poisoning occurs when its concentration in the inspiratory air exceeds 0.08 %. Concentration growth up to 0.32 % results in paralysis and loss of consciousness (with imminent death in about 30 minutes). Concentrations in excess of 1.2 % lead to loss of consciousness after 2-3 aspirations whereas another 2-3 minutes are fatal. Smoke spreads much faster than fire, therefore causing loss of consciousness and cardiac arrest before the victim reaches the safety outdoors. Furthermore, smoke contamination impacts spatial orientation forcing the victim to negotiate obstacles by touch and, quite often, to diverge from the escape paths.

FIRE IN A BUILDING WITHOUT A SMOKE CONTROL SYSTEM

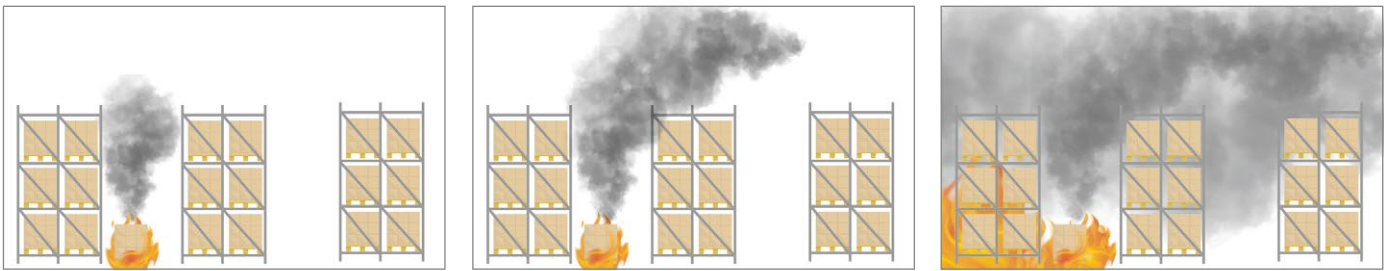

FIRE IN A BUILDING EQUIPPED WITH A SMOKE CONTROL SYSTEM

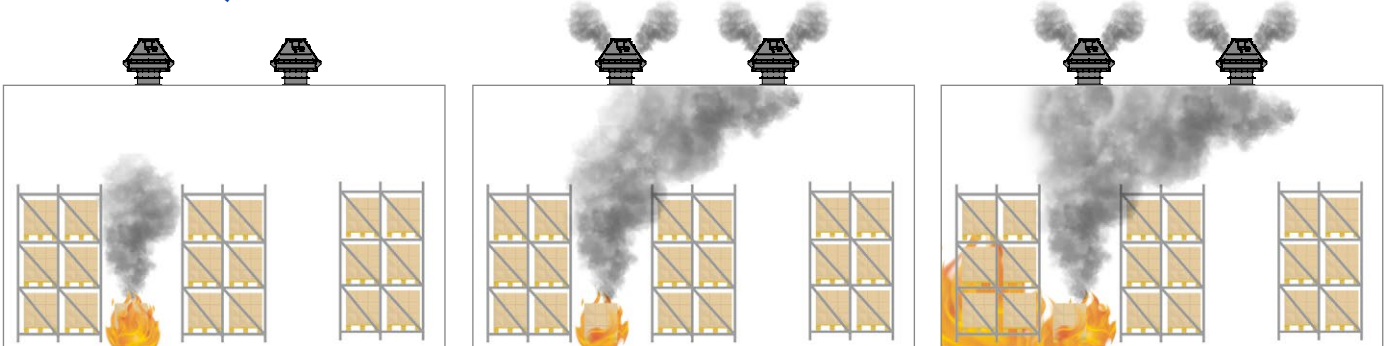

SMOKE CONTROL SYSTEM SOLUTION

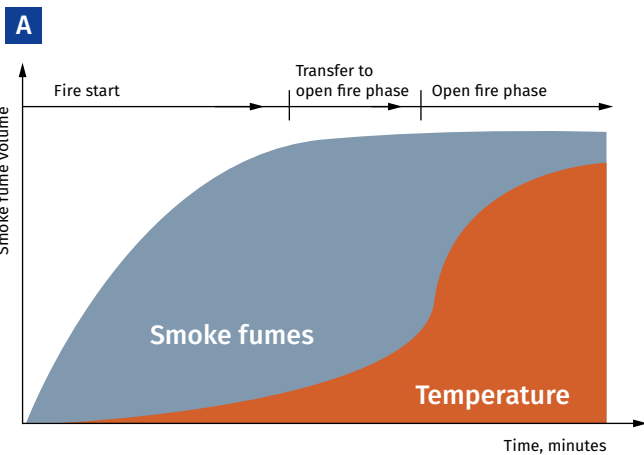

The A chart clearly shows that at the fire origin where no fire control systems are present, the smoke fume volume rapidly becomes critical.

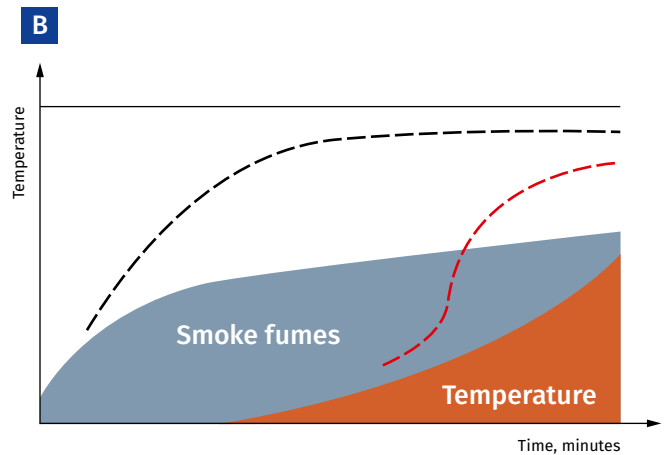

However, the B chart shows that a fire control extraction system helps to significantly reduce the content of smoke in the gas environment which remains below the safety threshold during the entire duration of fire.

IMPURITY CONTENT IN THE AIR [MG/M³] AND HEALTH EFFECT

Influence	CO	SO ₂	NOx
No marked effect in case of exposure for several hours	115	6	15
Symptoms of light poisoning or mucous membrane irritation in 2-3 hours	115...575	130	20
Poisoning in 30 minutes	2300...3500	210...400	100
Life hazard even if short-term exposure	5700	1600	150

COMPOSITION OF AUTOMOTIVE EXHAUST GASES

Content, volume in %	Petrol type	Diesel type
N ₂	74-77	76-78
O ₂	0.3-0.8	2.0-18.0
H ₂ O (vapours)	3.0-5.5	0.5-4.0
CO ₂	0.0-16.0	1.0-10.0
CO*	0.1-5.0	0.01-0.5
Nitrogen oxide*	0.0-0.8	0.0002-0.5000
Hydrocarbons*	0.2-3.0	0.09-0.500
Aldehydes*	0.0-0.2	0.001-0.009
Soot** [g/m ³]	0.0-0.04	0.01-1.10
Benzpyrene3.4** [g/m ³]	10-20 x 10 ⁻⁶	10 x 10 ⁻⁶

* Toxic components
 ** Carcinogens

SMOKE CONTROL SYSTEM FUNCTIONS:

- o Prevention of smoke spreading from the ignition source.
- o Prevention of smoke transfer to the evacuation paths (maintaining acceptable conditions for the people being evacuated from the building).
- o Maintaining a microclimate beyond the ignition source area to enable normal operation of fire-fighting teams.
- o Protecting life of people in the building.
- o Protecting property against damage.

DESIGN:

- o The smoke control system elements are integrated at the initial phase of the building (residential complex, office block, warehouse facility etc.) construction. These communications must be contained in the design engineering documents specific to the life-support system. All the works

specific to the design and installation of smoke control systems are strictly covered by the applicable construction standards and regulations.

- o Smoke control plays a paramount role in making a building safe and ensuring compliance with any and all fire safety standards and regulations. Purpose-built smoke exhaust duct lines provide additional safety and enable easy evacuation of people using corridors and stairs which are completely free of hazardous fumes.
- o Smoke control is a complex process affected by numerous conditions and factors, and, therefore, the design of such communication systems requires an expert qualification. Smoke control systems must only be designed by professionals since any disregard of the commonly accepted state regulations may lead to human casualties.

SMOKE CONTROL SYSTEM SOLUTION

SMOKE CONTROL SYSTEMS CONSIST OF:

- o **Smoke extraction fans** which are used in emergency exhaust ventilation systems for forced extraction of smoke and heated gases and simultaneous transfer of heat generated by the fire away and beyond the limits of the serviced spaces where the ignition occurs. Such units are used in production, public, residential, administrative and other spaces. Such fans are capable of handling smoke and air mixtures with temperatures up to 600 °C.
- o **Pressurization fans** are intended for creating a positive pressure differential in lift shafts, at landings and in air-lock corridors to prevent their contamination by smoke.
- o **Smoke dampers** installed on the protected premises accept smoke fumes and direct them into smoke shafts. Such devices are equipped with electric magnet or electric actuators. The dampers are rated according to the fire-resistance limit which can vary up to 180 minutes at the smoke temperature of 600 °C.
- o **Fire-resisting dampers** are installed in exhaust ventilation and general ventilation systems to prevent the spread of fire hazards (fire and smoke fumes). Such units are equipped with an electric actuator or a thermal lock.
- o **Ventilation air ducts and shafts** are intended for transferring smoke fumes from the protected premises away from the building. Air ducts are made of non-combustible materials.



SAMPLE SCHEME AND OPERATION OF A SMOKE EXTRACTION SYSTEM IN A MULTI-STOREY RESIDENTIAL BUILDING WITH AN UNDERGROUND CAR PARK

SMOKE CONTROL SYSTEM SOLUTION

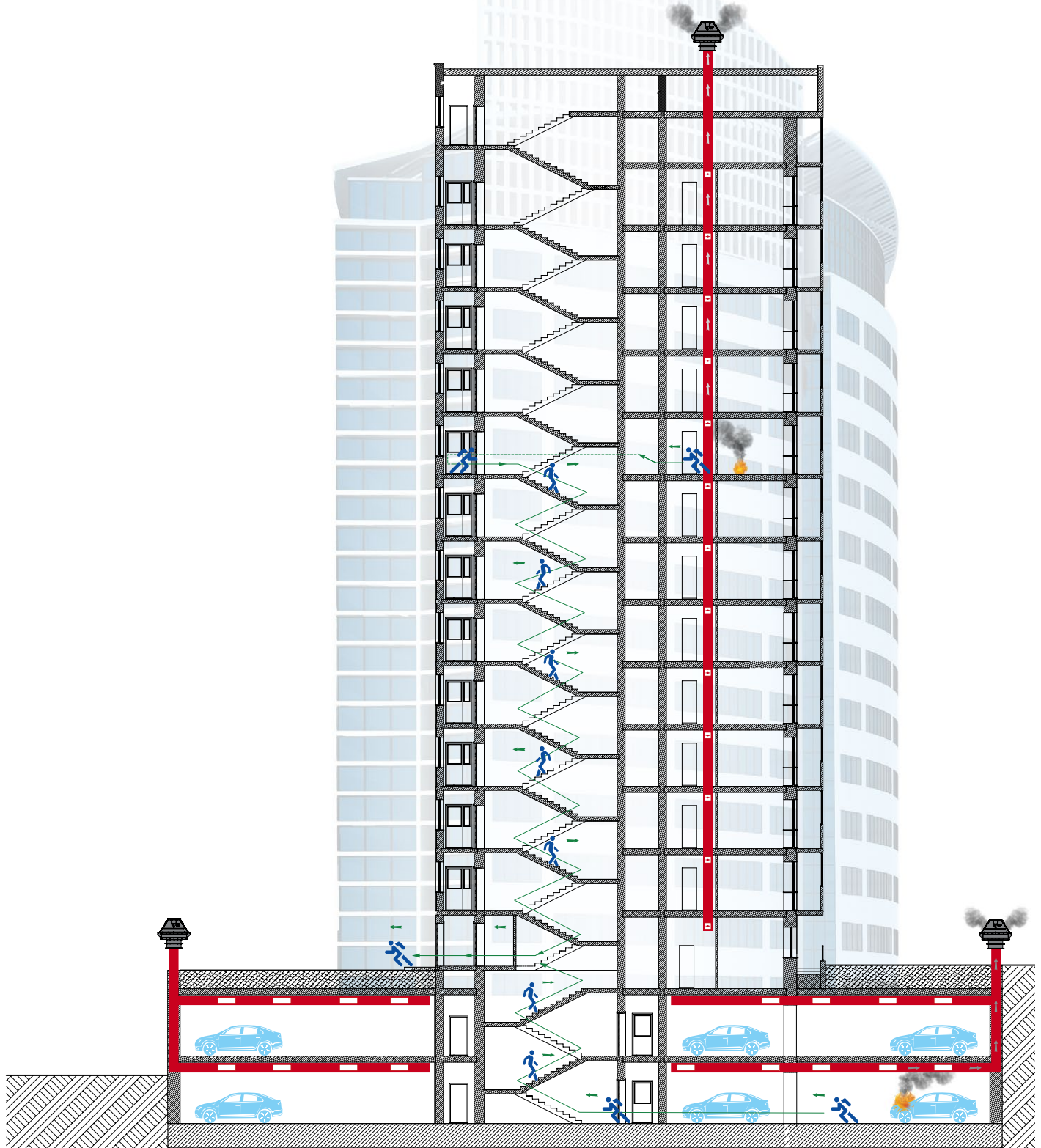

Typical smoke control system solution in case of a fire on the second floor:
Ventilation system: fire-resisting dampers BSK ③ and ④ block the floor 2 (closed), thus containing the fire and smoke at the ignition floor, fire-resisting dampers BSK ② and ⑥ remain open enabling pressurisation of the adjacent floors 1 and 3 by the supply ventilation system while fire-resisting dampers BSK ① and ⑤ in the exhaust ventilation branch remain closed.

Smoke control system: smoke extraction is handled by the Tower-SH / Tower-SV fan via the open RSKM ⑪ damper, the supply air is fed from the air pressurisation system via the open damper ⑧ while dampers ⑦, ⑨, ⑩ and ⑫ remain closed.

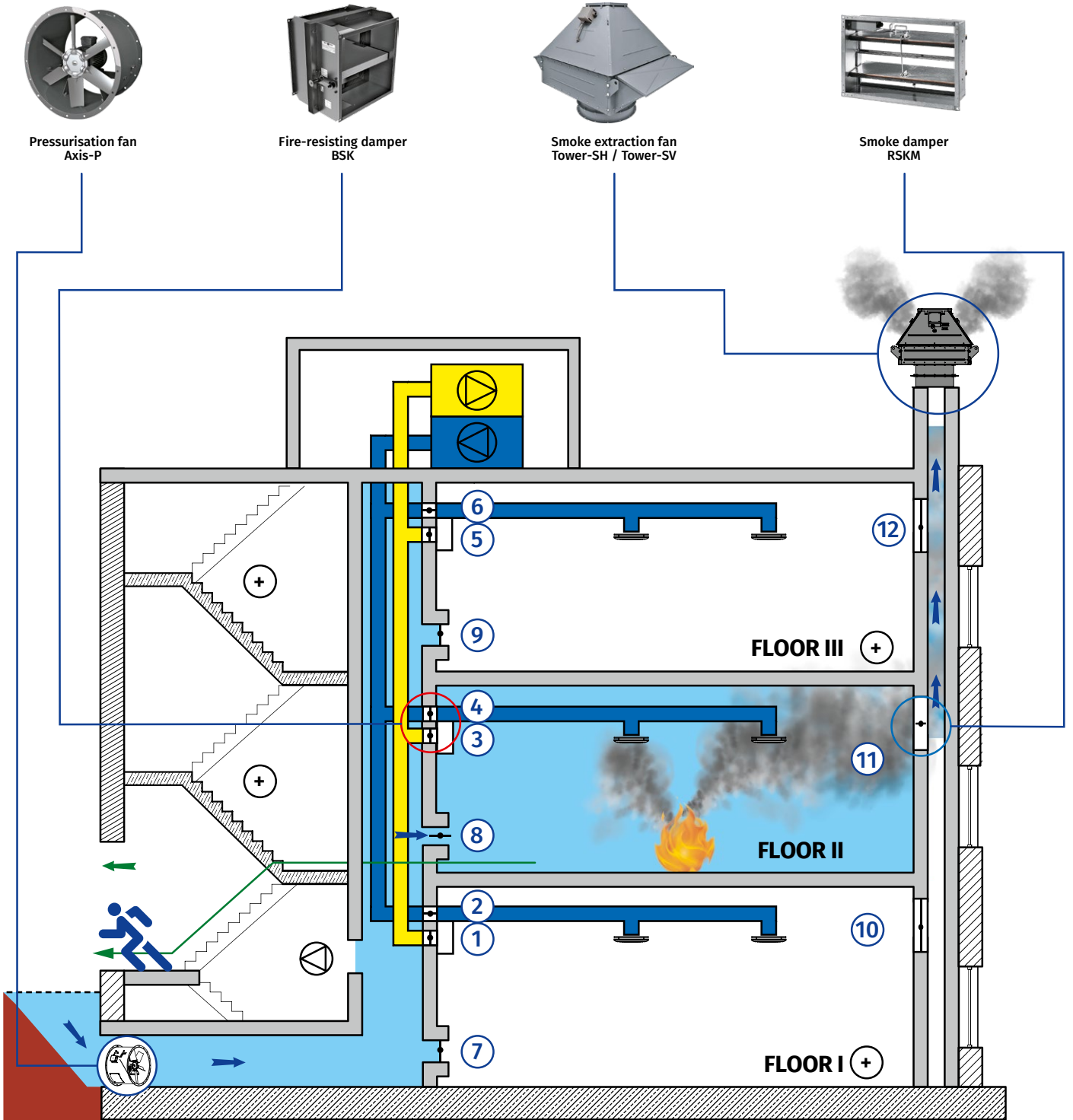

SMOKE CONTROL SYSTEM SOLUTION

SMOKE EXTRACTION FOR UNDERGROUND PARKING

Underground parking ventilation example

SMOKE CONTROL SYSTEM SOLUTION

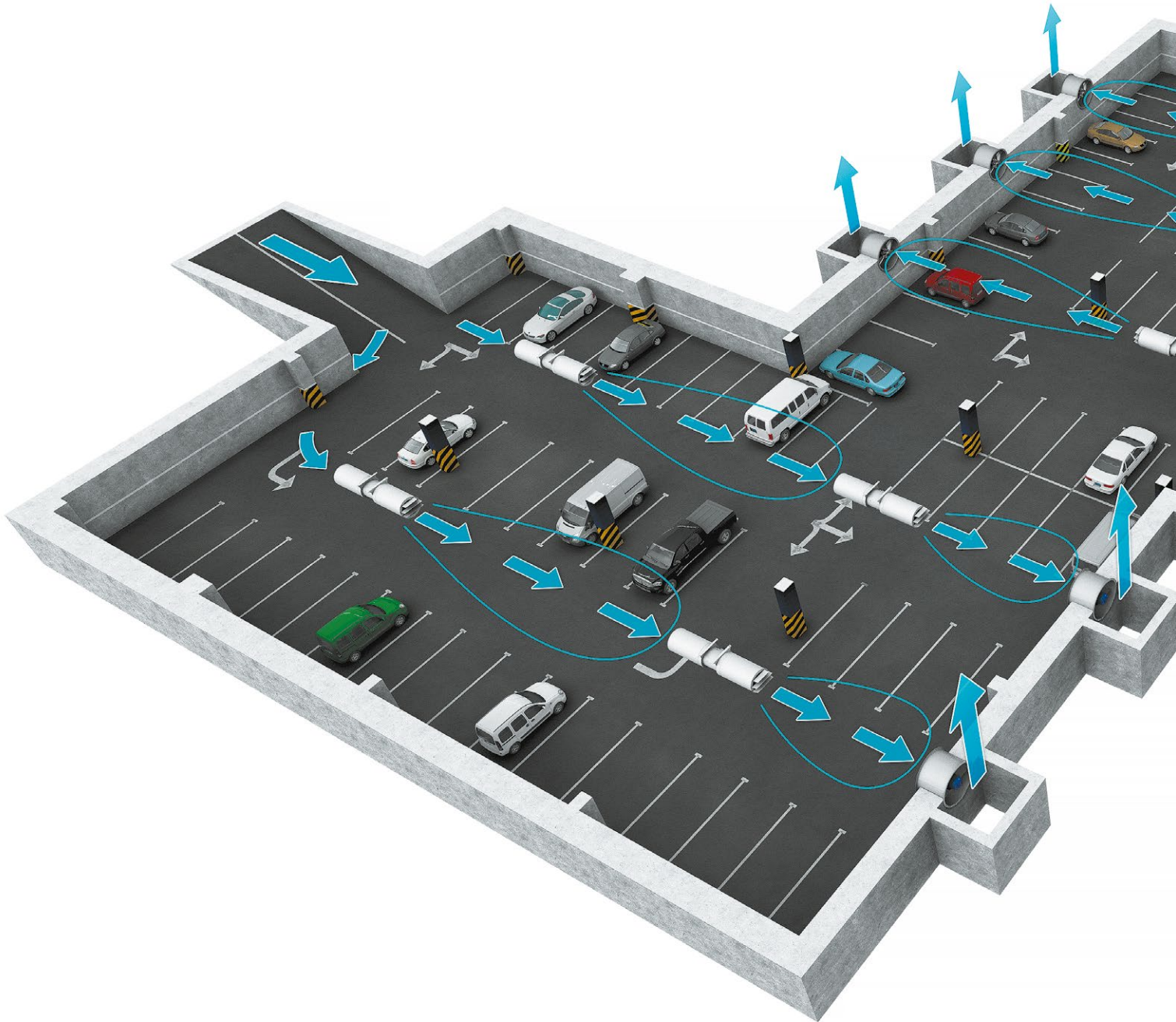

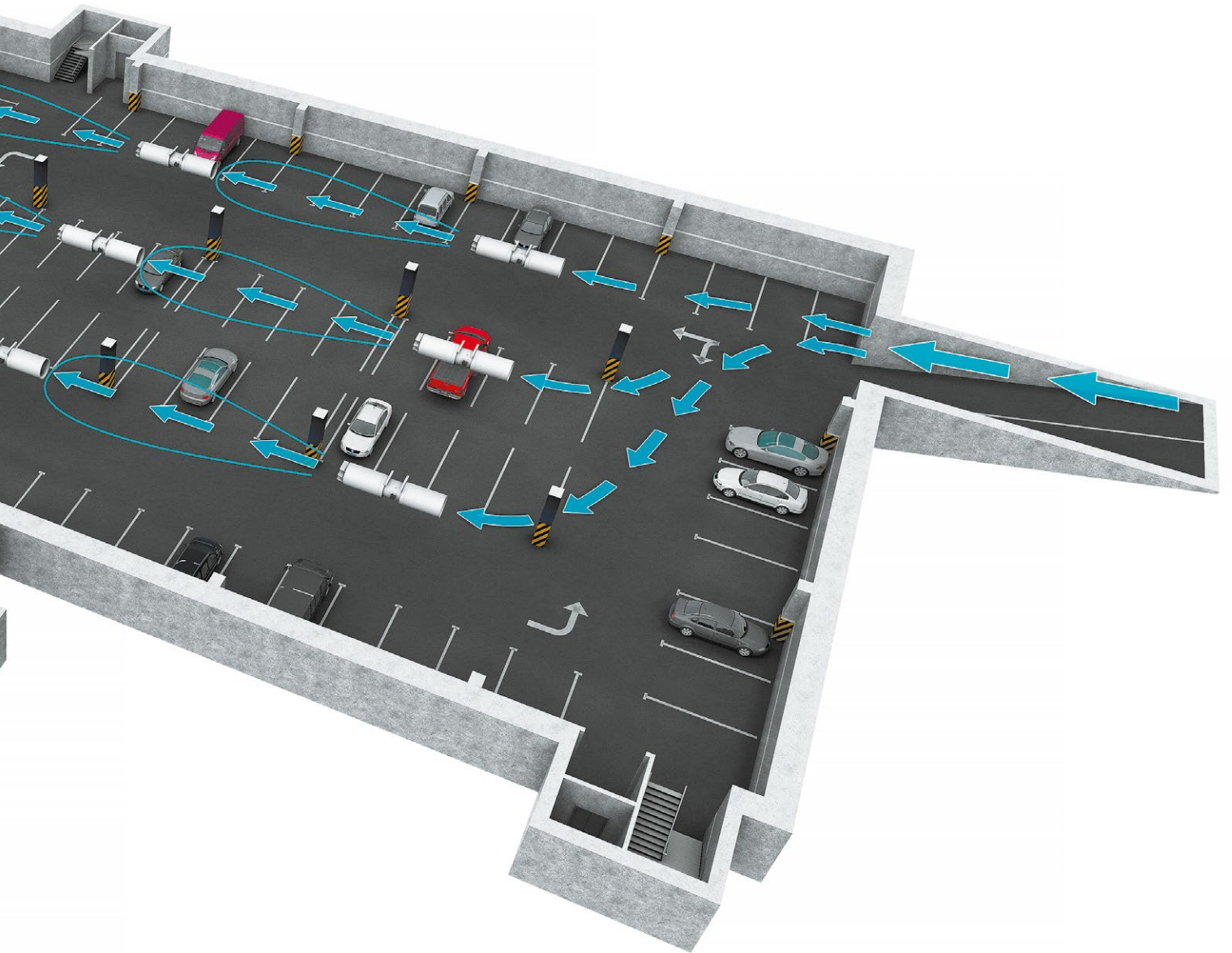

SMOKE CONTROL SYSTEM SOLUTION

Underground parking smoke extraction example

SMOKE CONTROL SYSTEM SOLUTION

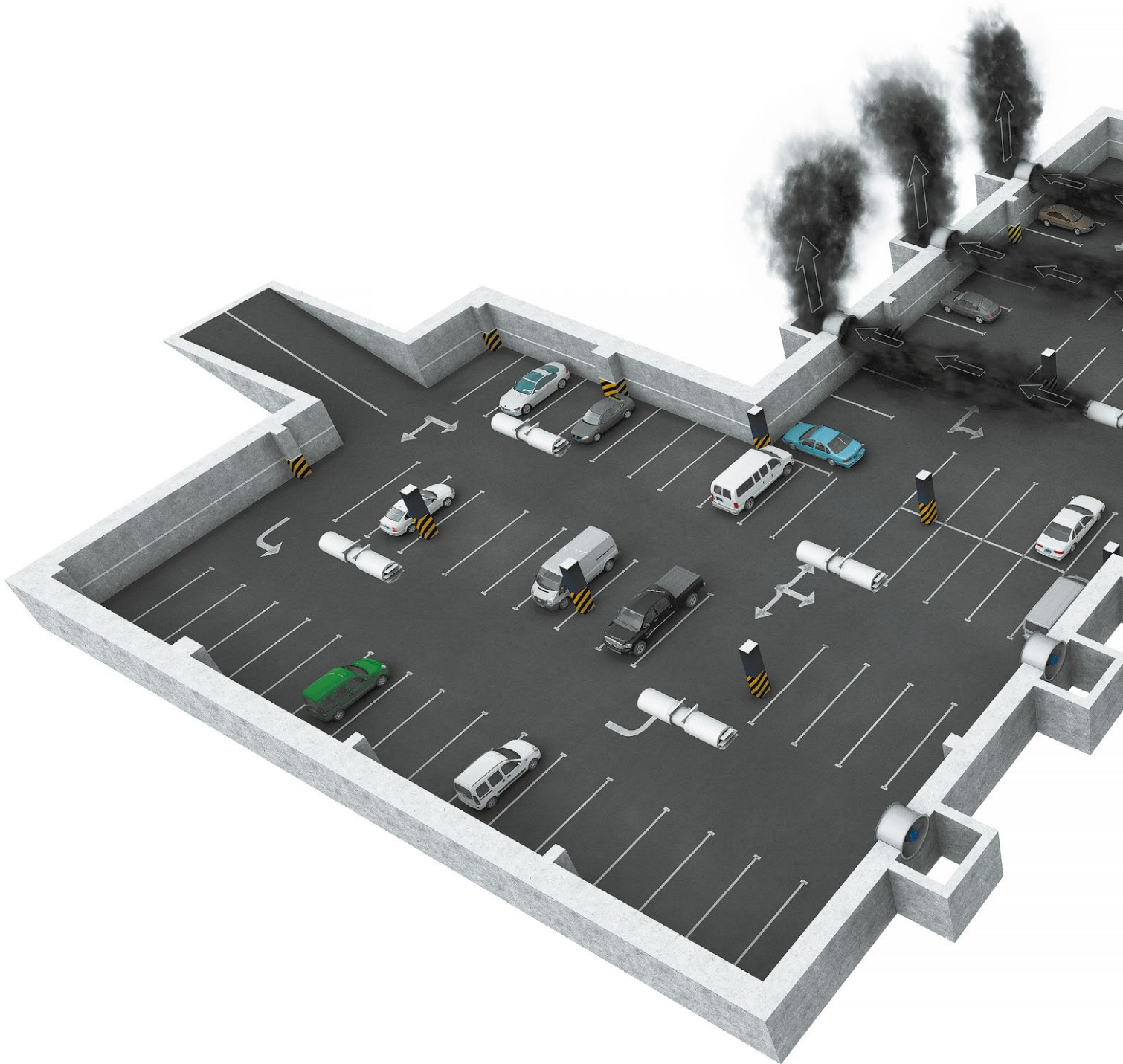



SMOKE CONTROL SYSTEM SOLUTION

ROOF-MOUNTED SMOKE EXTRACTION FANS

Roof-mounted centrifugal smoke extraction fans
Tower-SV / Tower-SH

12

TOWER-SV / TOWER-SH

Roof-mounted centrifugal smoke extraction fans

Use

- Smoke extraction fans are used in emergency exhaust ventilation systems for forced extraction of smoke and heated gases and simultaneous transfer of heat away and beyond the limits of the serviced spaces in case of fire.
- Such units are used in production, public, residential, administrative and other spaces.



Air flow:
up to 105 000 m³/h



Transported air temperature:
600 °C/2 hours



Operation

- The fans are capable of handling smoke and air mixtures with temperatures up to +600 °C for 120 minutes.
- The fans can operate in conjunction with a frequency converter (herein-after referred to as FC) or directly when connected to power supply. The relevant characteristics for these modes are listed in the tables below.
- The fan can be used for general exhaust ventilation at a rotational speed reduced by at least 25 % of the nominal speed of the electric motor.
- The fan can be designed for moderate (**U**) or tropical (**T**) climate conditions.

Design

- The fans are made of heat resistant steel with polymer coating providing weathering resistance.
- There are two types of roof-mounted smoke extraction fans: with horizontal air discharge (**Tower-SH**) and vertical air discharge (**Tower-SV**).
- The models with vertical air discharge are equipped with a backdraft damper. The fan has a protective grille to prevent accidental contact and penetration of foreign objects. The impeller with backward curved blades is painted with powder coating.

Motor

- The fans are equipped with three-phase electric motors rated for 400 V.
- The motor is located in the compartment offset from the transported air stream. Motor ingress protection rating is IP54.

Mounting

- The roof fans are installed on the **MRDL** (simplified version) or **MIRDL** mounting frame (heat-insulated version).
- The **MRDL** and **MIRDL** mounting frames are designed for mounting the fan on the roof without a slope.
- Make sure that the location provides for sufficient space as required for the fan maintenance.



MRDL 630
MRDL 710-800
MRDL 900
MRDL 1000-1100

Designation key

	TOWER-S	V	630	1.5/720	M	Zn
Fan series: Roof-mounted smoke extraction fan						
Air discharge direction: V: vertical H: horizontal						
Impeller diameter [mm]: 630; 710; 800; 900; 1000; 1100						
Rated power of the electric motor [kW] / Motor speed [RPM]: 1.5...37/720...1470						
Terminal box: _: no terminal box M: terminal box						
_: RAL7040 gray by default RALxxx: paint colour according to RALxxx Zn: galvanized steel						

Overall dimensions [mm]

Model	H	H1	L1	L2	L3	L4	∅ D	∅ D1	∅ D2	∅ d1	∅ d2	n	Weight [kg]	MRDL, MIRDL mounting frame compatibility			
Tower-SV(SH) 630 1.5/930	1038	302	1424	750	955	1153	503	541	634	10	21	12	200	MRDL/MIRDL 630			
Tower-SV(SH) 630 2.2/940		210											225		216	230	
Tower-SV(SH) 630 3/960	1043	307	1424	750	955	1153	503	541	634	10	21	12	225		MRDL/MIRDL 630		
Tower-SV(SH) 630 4/1440	1038	302											216			230	
Tower-SV(SH) 630 5.5/1450	1043	307	1424	750	955	1153	503	541	634	10	21	12	230			MRDL/MIRDL 630	
Tower-SV(SH) 630 7.5/1440	1134												255				
Tower-SV(SH) 710 2.2/940	1181	317	1508	840	1040	1238	633	674	730	12	21	16	242				MRDL/MIRDL 710-800
Tower-SV(SH) 710 3/960	1186	322											252				
Tower-SV(SH) 710 4/950			253														
Tower-SV(SH) 710 5.5/960	280																
Tower-SV(SH) 710 7.5/1455	281																
Tower-SV(SH) 710 11/1460	292																
Tower-SV(SH) 800 4/960	1239	345	1543	840	1040	1238	633	674	784	12	21	16	286	MRDL/MIRDL 710-800			
Tower-SV(SH) 800 5.5/950													305				
Tower-SV(SH) 800 7.5/970	312																
Tower-SV(SH) 800 11/960	390																
Tower-SV(SH) 800 15/1460	390																
Tower-SV(SH) 800 18.5/1470	395																
Tower-SV(SH) 900 4/720	1379	363	1871	1050	1200	1398	713	751	874	12	21	16	376		MRDL/MIRDL 900		
Tower-SV(SH) 900 5.5/960	376																
Tower-SV(SH) 900 7.5/970	380																
Tower-SV(SH) 900 11/970	418																
Tower-SV(SH) 900 15/960	433																
Tower-SV(SH) 900 18.5/960	482																
Tower-SV(SH) 900 22/960	566																
Tower-SV(SH) 1000 5.5/720	1365	398	2111	1240	1430	1628	803	837	974	12	23	24	467	MRDL/MIRDL 1000-1100			
Tower-SV(SH) 1000 7.5/730	588																
Tower-SV(SH) 1000 11/970	590																
Tower-SV(SH) 1000 15/970	595																
Tower-SV(SH) 1000 18.5/970	639																
Tower-SV(SH) 1000 22/970	670																
Tower-SV(SH) 1000 30/970	690																
Tower-SV(SH) 1100 11/730	720																
Tower-SV(SH) 1100 15/730	775																
Tower-SV(SH) 1100 18.5/970	1721	441	2236	1240	1430	1628	903	934	1075	12	23	24	763		MRDL/MIRDL 1000-1100		
Tower-SV(SH) 1100 22/970	794																
Tower-SV(SH) 1100 30/970	812																
Tower-SV(SH) 1100 37/980	1773	930															

ROOF-MOUNTED SMOKE EXTRACTION FANS

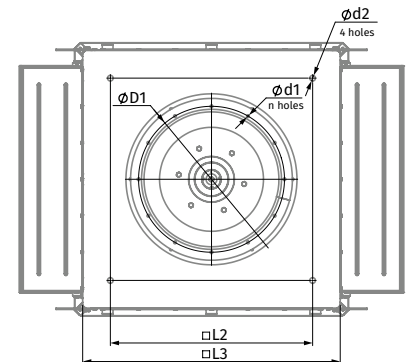
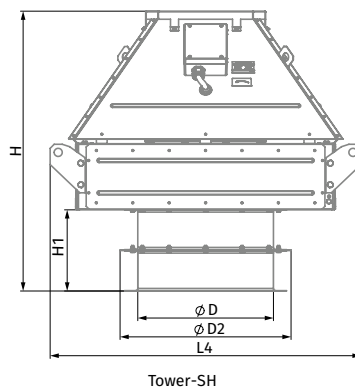
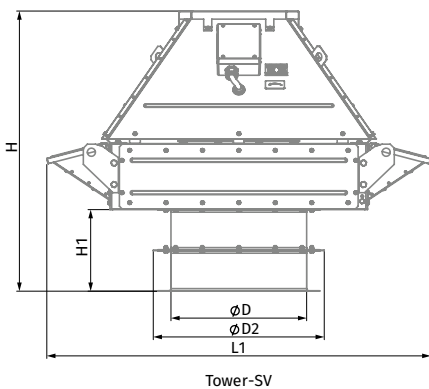

Overall dimensions of MRDL and MIRD L mounting frames [mm]

Model	A	B	C	H	M	Weight MRDL [kg]	Weight MIRD L [kg]
MRDL/MIRD L 630	1212	912	750	600	M18	65.9	85.45
MRDL/MIRD L 710-800	1262	962	840	600	M18	68.5	89.04
MRDL/MIRD L 900	1512	1212	1050	650	M18	85.7	113
MRDL/MIRD L 1000-1100	1712	1412	1240	730	M20	103.7	140.59

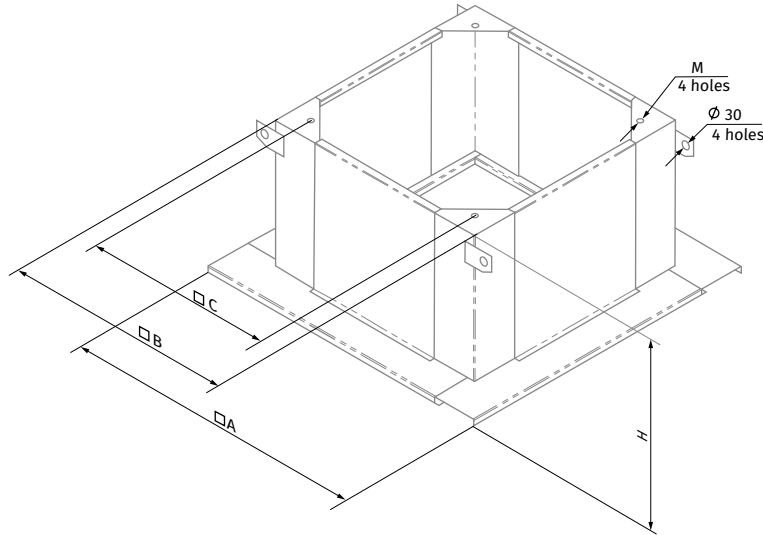

Technical data

Parameters	Tower-SV/SH 630 1.5/930	Tower-SV/SH 630 2.2/940	Tower-SV/SH 630 3.0/960	Tower-SV/SH 630 4.0/1440	Tower-SV/SH 630 5.5/1450	Tower-SV/SH 630 7.5/1440
Voltage [V]	3~400	3~400	3~400	3~400	3~400	3~400
Rated frequency [Hz]	50	50	50	50	50	50
Rated power Ny [kW]	1.5	2.2	3.0	4.0	5.5	7.5
Rated current [A]	3.7	5.6	7.4	8.8	11.3	15.5
Rated RPM [min ⁻¹]	930	940	960	1440	1450	1440
Maximum RPM when operating from FC [min ⁻¹]	1010	1160	1280	1370	1550	1730
Maximum frequency when operating from FC [Hz]	54	62	67	48	53	60
Curve number at the diagram when operating from FC	①	②	③	④	⑤	⑥
Curve number at the diagram when operating from supply network	⑦	⑧	⑨	-	⑩	⑪

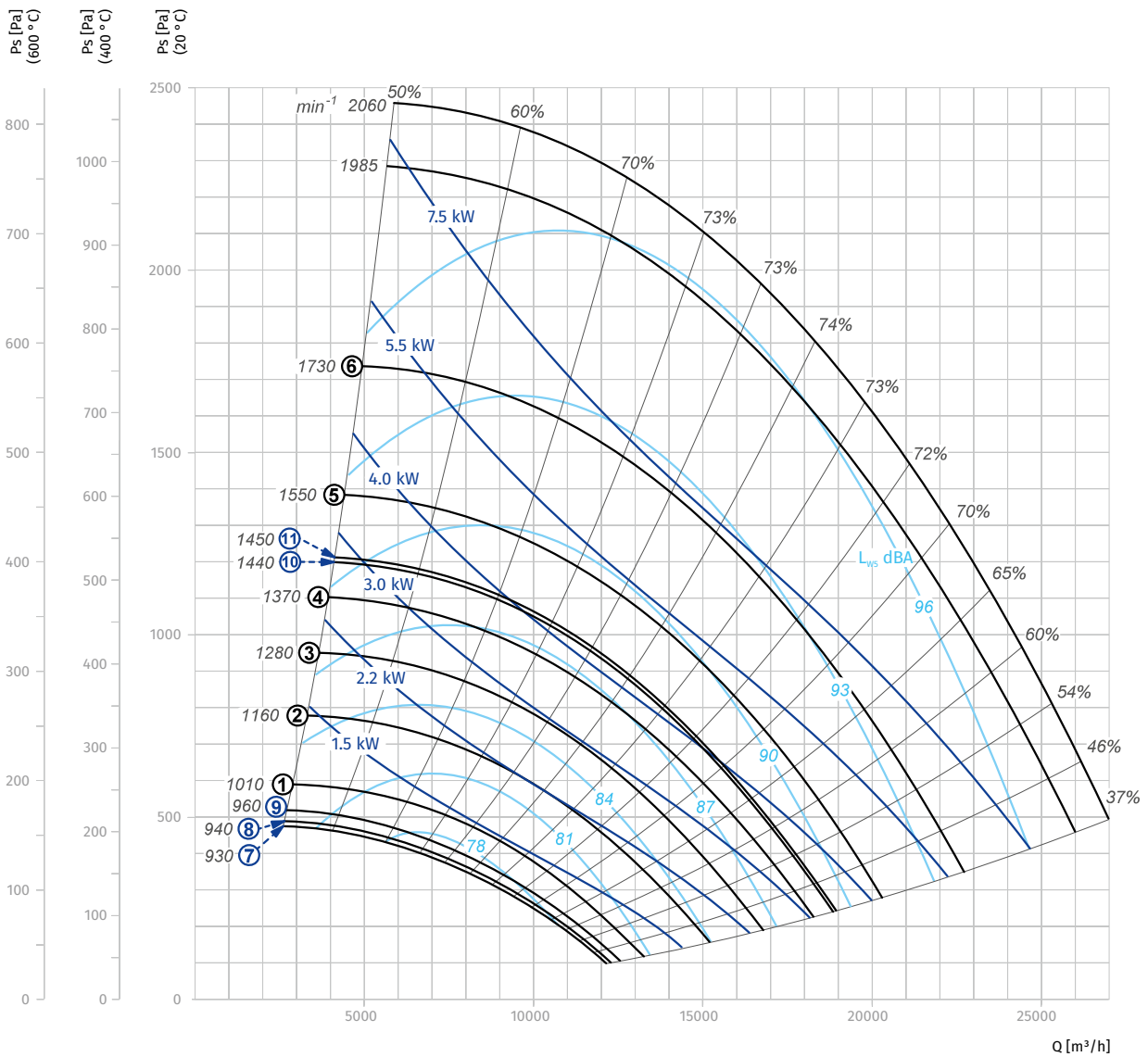

Parameters	Tower-SV/SH 710 2.2/940	Tower-SV/SH 710 3/960	Tower-SV/SH 710 4/950	Tower-SV/SH 710 5.5/960	Tower-SV/SH 710 7.5/1455	Tower-SV/SH 710 11/1460
Voltage [V]	3~400	3~400	3~400	3~400	3~400	3~400
Rated frequency [Hz]	50	50	50	50	50	50
Rated power Ny [kW]	2.2	3.0	4.0	5.5	7.5	11.0
Rated current [A]	5.3	7.4	8.4	11.2	15.1	21.2
Rated RPM [min ⁻¹]	940	960	950	960	1455	1460
Maximum RPM when operating from FC [min ⁻¹]	940	1050	1140	1280	1380	1620
Maximum frequency when operating from FC [Hz]	50	55	60	67	47	55
Curve number at the diagram when operating from FC	①	②	③	④	⑤	⑥
Curve number at the diagram when operating from supply network	⑦	⑨	⑧	⑨	-	⑩

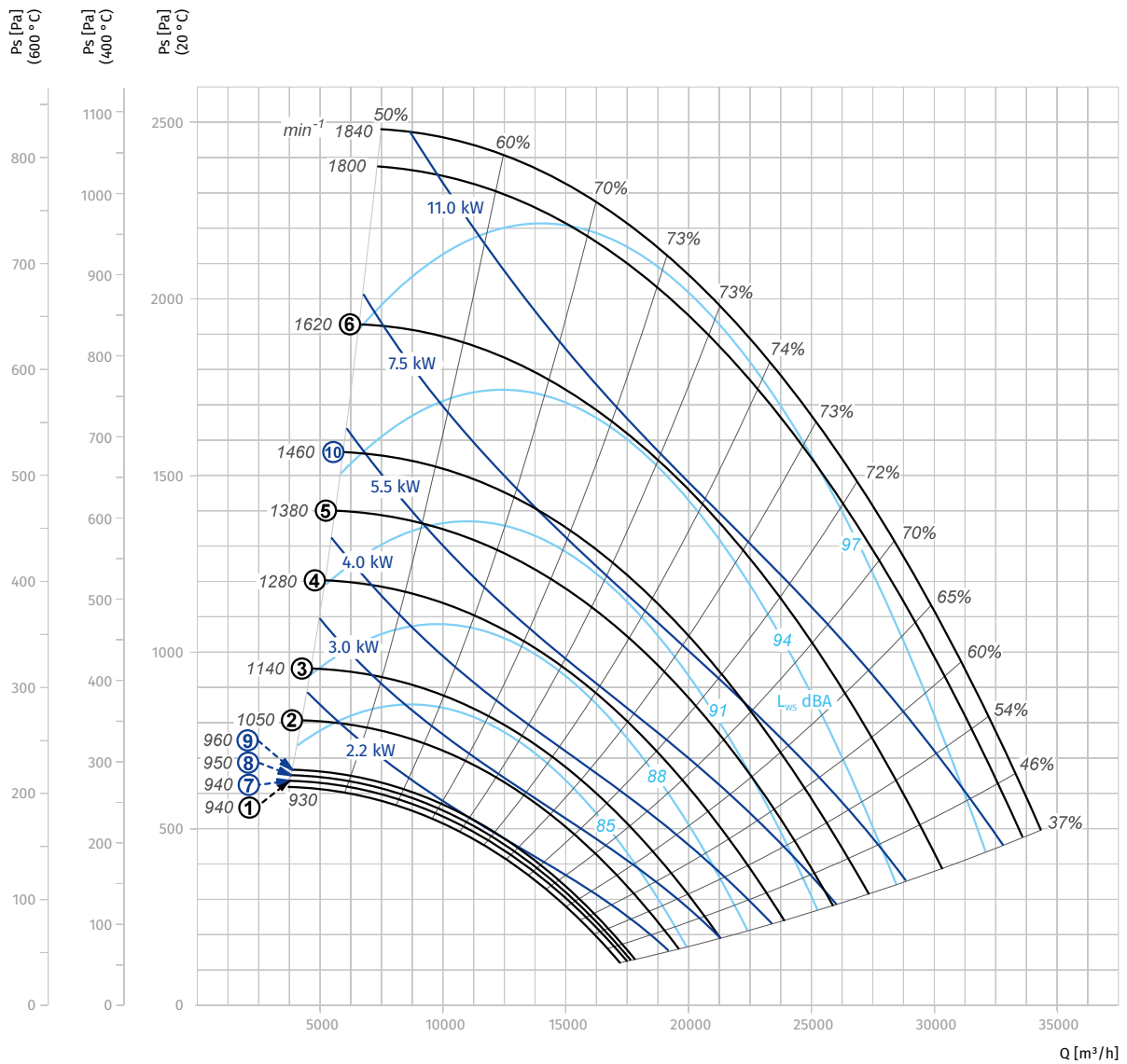

Parameters	Tower-SV/SH 800 4/960	Tower-SV/SH 800 5.5/950	Tower-SV/SH 800 7.5/970	Tower-SV/SH 800 11/960	Tower-SV/SH 800 15/1460	Tower-SV/SH 800 18.5/1470
Voltage [V]	3~400	3~400	3~400	3~400	3~400	3~400
Rated frequency [Hz]	50	50	50	50	50	50
Rated power Ny [kW]	4.0	5.5	7.5	11.0	15.0	18.5
Rated current [A]	9.2	12.3	15.7	21.2	29.5	36.4
Rated RPM [min ⁻¹]	960	950	970	960	1460	1470
Maximum RPM when operating from FC [min ⁻¹]	960	1050	1170	1330	1480	1580
Maximum frequency when operating from FC [Hz]	50	55	60	69	51	54
Curve number at the diagram when operating from FC	①	②	③	④	⑤	⑥
Curve number at the diagram when operating from supply network	⑧	⑦	⑨	⑧	⑩	⑪

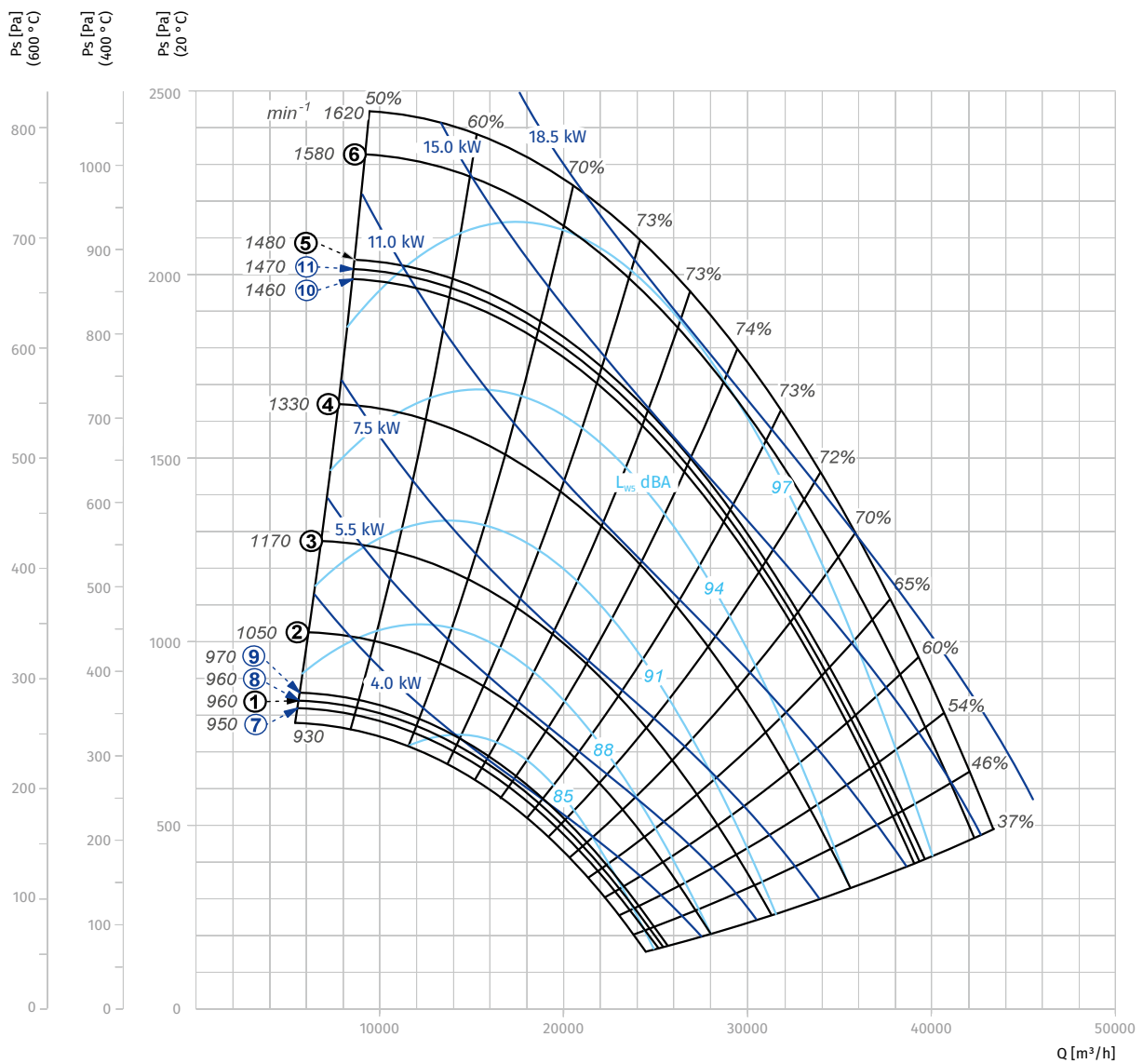

ROOF-MOUNTED SMOKE EXTRACTION FANS

Parameters	Tower-SV/SH 900 4/720	Tower-SV/SH 900 5.5/960	Tower-SV/SH 900 7.5/970	Tower-SV/SH 900 11/970	Tower-SV/SH 900 15/960	Tower-SV/SH 900 18.5/960	Tower-SV/SH 900 22/960
Voltage [V]	3~400	3~400	3~400	3~400	3~400	3~400	3~400
Rated frequency [Hz]	50	50	50	50	50	50	50
Rated power Ny [kW]	4.0	5.5	7.5	11.0	15.0	18.5	22.0
Rated current [A]	10.0	12.3	15.7	23	31.0	36.4	44
Rated RPM [min ⁻¹]	720	960	970	970	960	960	960
Maximum RPM when operating from FC [min ⁻¹]	770	860	970	1070	1210	1290	1370
Maximum frequency when operating from FC [Hz]	53	45	50	55	63	67	71
Curve number at the diagram when operating from FC	①	②	③	④	⑤	⑥	⑦
Curve number at the diagram when operating from supply network	⑧	-	⑩	⑩	⑨	⑨	⑨

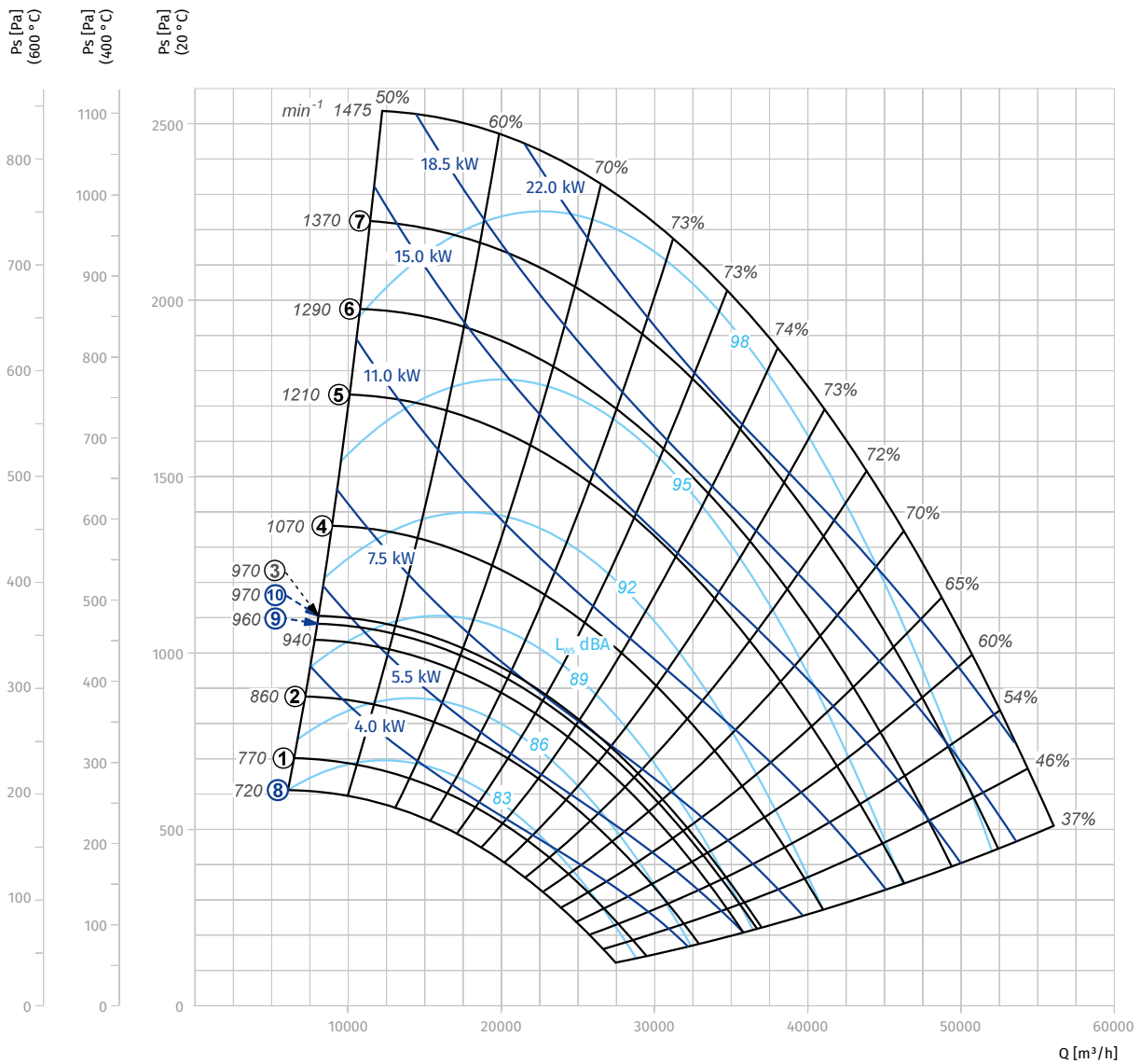

ROOF-MOUNTED SMOKE EXTRACTION FANS

Parameters	Tower-SV/SH 1000 5.5/720	Tower-SV/SH 1000 7.5/730	Tower-SV/SH 1000 11/970	Tower-SV/SH 1000 15/970	Tower-SV/SH 1000 18.5/970	Tower-SV/SH 1000 22/970	Tower-SV/SH 1000 30/970
Voltage [V]	3~400	3~400	3~400	3~400	3~400	3~400	3~400
Rated frequency [Hz]	50	50	50	50	50	50	50
Rated power Ny [kW]	5.5	7.5	11.0	15.0	18.5	22.0	30.0
Rated current [A]	13.6	18	23.0	31.0	36.5	44.6	59.6
Rated RPM [min ⁻¹]	720	730	970	970	970	970	970
Maximum RPM when operating from FC [min ⁻¹]	690	770	880	990	1060	1110	1230
Maximum frequency when operating from FC [Hz]	48	53	45	51	55	57	63
Curve number at the diagram when operating from FC	①	②	③	④	⑤	⑥	⑦
Curve number at the diagram when operating from supply network	-	⑧	-	⑨	⑨	⑨	⑨

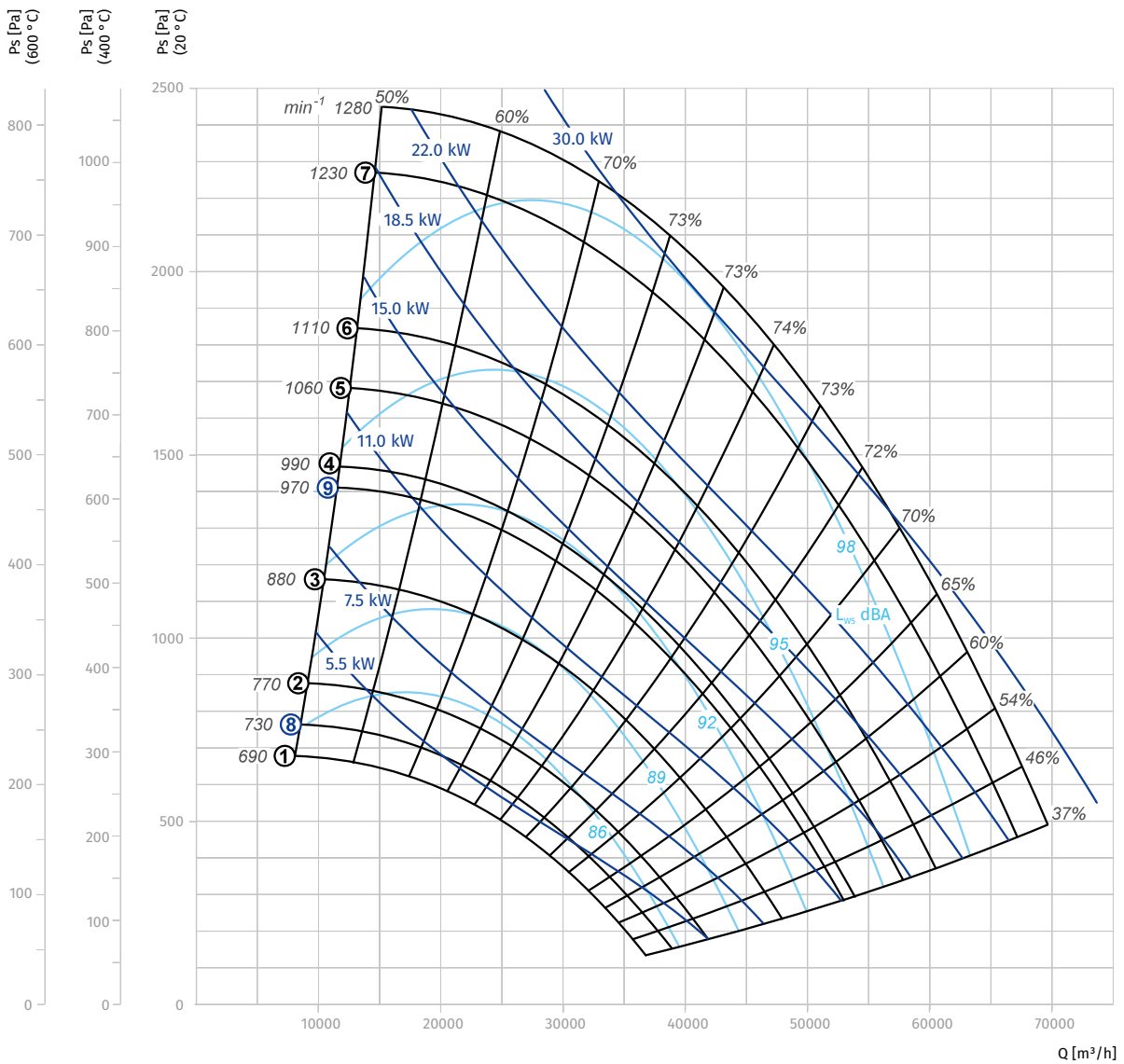

Parameters	Tower-SV/SH 1100 11/730	Tower-SV/SH 1100 15/730	Tower-SV/SH 1100 18.5/970	Tower-SV/SH 1100 22/970	Tower-SV/SH 1100 30/970	Tower-SV/SH 1100 37/980
Voltage [V]	3~400	3~400	3~400	3~400	3~400	3~400
Rated frequency [Hz]	50	50	50	50	50	50
Rated power Ny [kW]	11.0	15.0	18.5	22.0	30.0	37.0
Rated current [A]	25.1	32.3	36.5	44.6	59.6	70.0
Rated RPM [min ⁻¹]	730	730	970	970	970	980
Maximum RPM when operating from FC [min ⁻¹]	715	775	830	880	980	1040
Maximum frequency when operating from FC [Hz]	49	53	43	45	51	53
Curve number at the diagram when operating from FC	①	②	③	④	⑤	⑥
Curve number at the diagram when operating from supply network	-	⑦	-	-	⑧	⑨

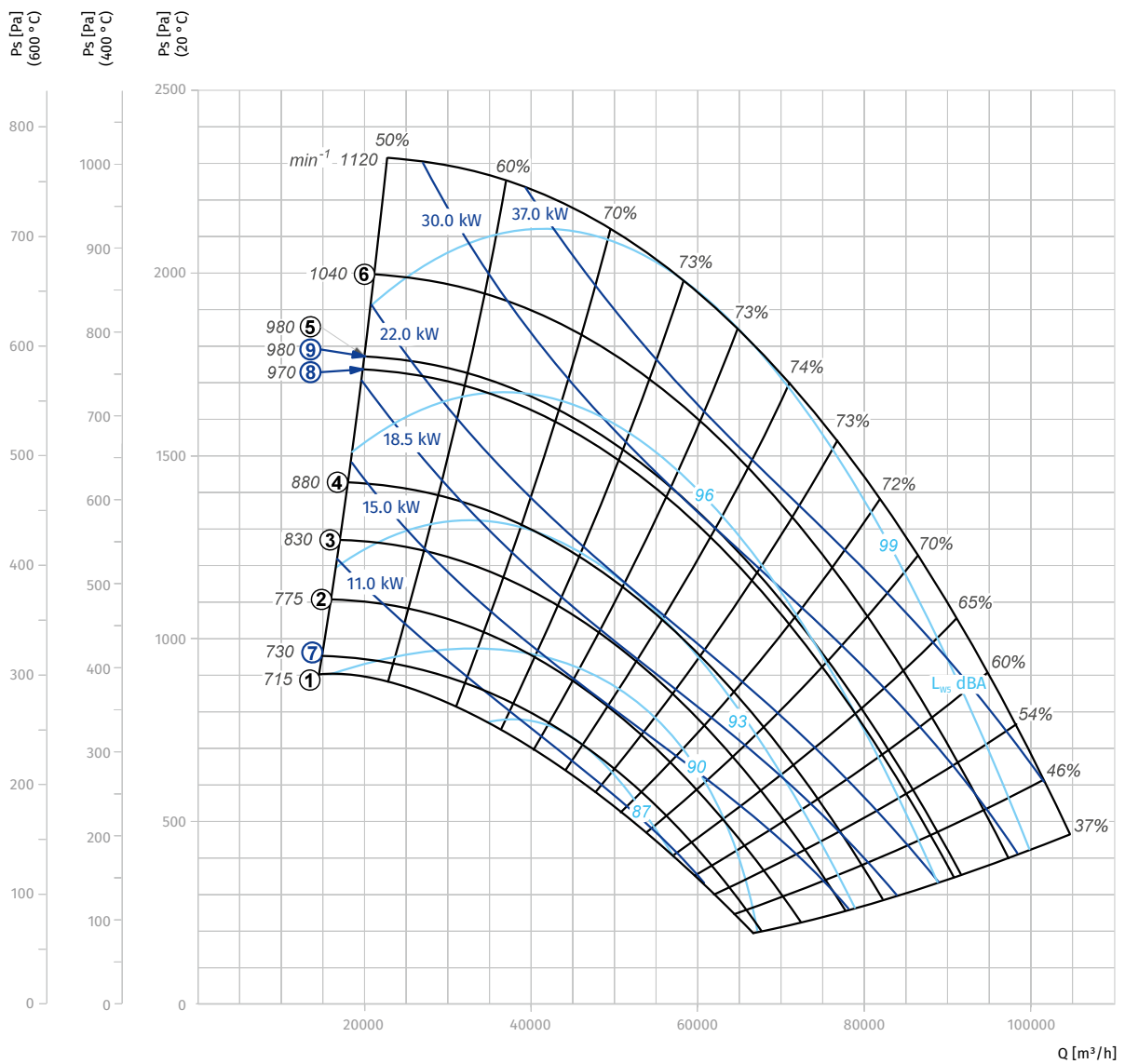

AXIAL SMOKE EXTRACTION FANS

Complete solutions for axial fans	24
Medium pressure axial fans Axis-P	26
Axial smoke extraction fans Axis-FP	50
Fan accessories selection table	118

COMPLETE SOLUTIONS FOR AXIAL FANS

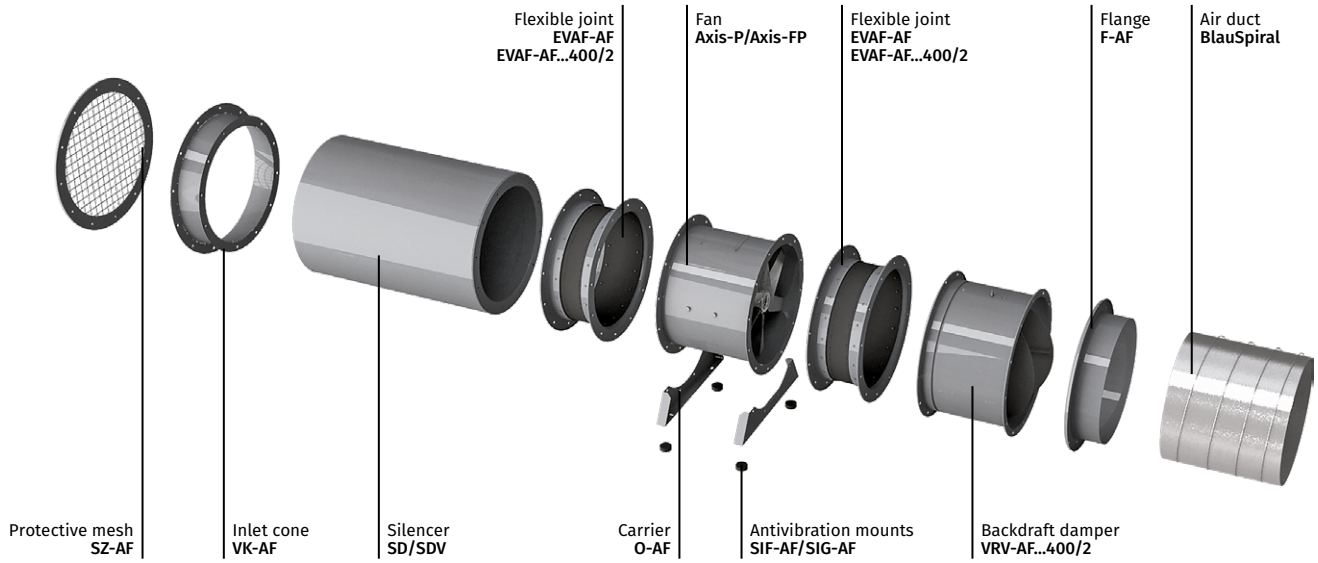

AXIAL SMOKE EXTRACTION FANS

Installation example of axial fans on rooftop

Air pressurisation system

Smoke extraction system

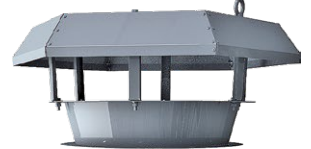

Roof hood Z-AF



Backdraft damper VRV1-AF

Fire-resistant backdraft damper VRV-AF...400/2



Axial fan Axis-P

Axial smoke extraction fan Axis-FP

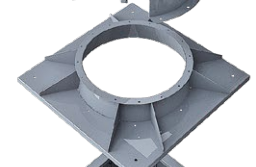
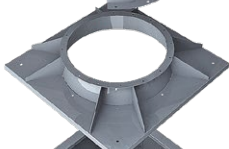

Roof adapter PK-AF

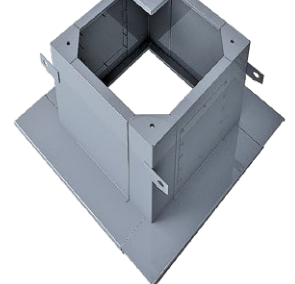
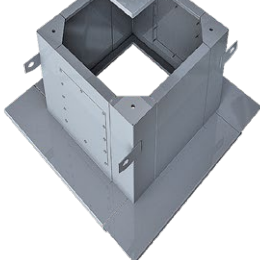

Mounting curb SM-AF

FAN INSTALLATION INTO AN AIR DUCT SYSTEM

- o To ensure a uniform air flow, the fan should be preceded by a straight duct section with a cross-section area equal to half of that of the fan. The length of the duct section should be $3 \div 4 D$ (D is the inner diameter of the fan). The length of the straight duct section downstream of the fan should be $1.5 \div 2 D$.
- o Reduction of the recommended duct length values results in a drop of the fan pressure and performance. To reduce noise and vibration, use the VVGF flexible joints.

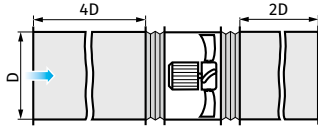

FAN INSTALLATION WITH NO UPSTREAM DUCTING

- o Axial fans without upstream ducting must be equipped with a VK-AF inlet cone to improve the air flow parameters.

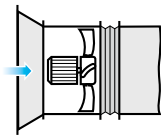

FAN INSTALLATION WITH NO DOWNSTREAM DUCTING

- o If the axial fan is a terminal device of the ventilation system (i.e. there is no downstream ducting), the unit must be equipped with a diffuser to reduce the air flow velocity and the fan dynamic pressure. Reduction of the air discharge velocity results in a significant reduction of shock losses which are proportional to the square of velocity decrement.
- o The fan should not be equipped with a downstream contractor.

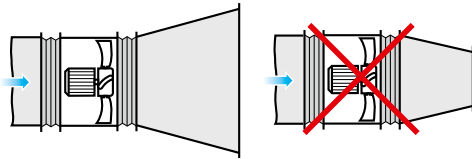

INSTALLATION NEAR BENDS

- o To install the fan directly downstream of a bend (elbow), use a curved section with a large bending radius or an array of internal guide vanes.

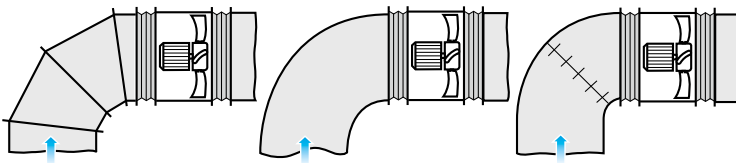

CHANGING DIAMETER INSTALLATION

- o When changing from a smaller diameter to a larger one use a connector diffuser with the maximum opening angle of 12° .

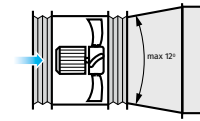

OBSTRUCTED SPACE INSTALLATION

- o To ensure normal operation of the fan in an obstructed space, make sure to provide for a sufficient distance between the inlet and outlet flanges and the floor, walls, bulky equipment and obstacles.

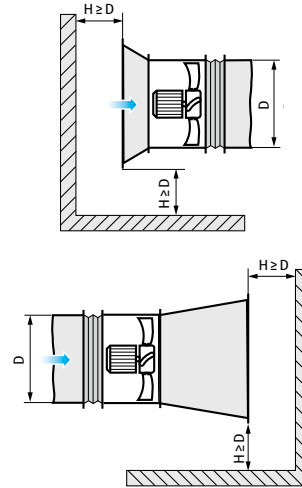

AXIS-P

Medium pressure axial fans

Use

The fans are used:

- as a part of a smoke extraction system for air pressurization to create a positive air pressure differential in stairway enclosures, airlock vestibules and lift shafts, to prevent spreading of smoke in premises, protect people using evacuation routes from fire hazards and enable conditions for fire-extinguishing measures.
- in general ventilation systems in industrial, administrative and residential buildings.



Air flow:
up to 113 000 m³/h



Design

- The metal casing with rolled flanges helps achieve outstanding rigidity and minimum clearances between the casing and the blades. There is an inspection hatch in the casing for easy maintenance.
- All the casing components are powder coated for improved protection against the environmental effects.
- The weight of the fans may differ from the one stated in the catalogue and depends on the components used (motor, terminal box, etc.).

Motor

- The fans are equipped with three-phase (400 V/50 Hz) single-speed 2-, 4- or 6-pole electric motors.
- Motor with energy efficiency class IE3 on request.
- Motor ingress protection rating is IP55.

Impeller

- Depending on the size and the required air capacity the fans are equipped with impellers with 6 or 8 blades angled from 20° to 50° with variation from 2.5 up to 5° to ensure precise matching of fans with the operating point.
- The specially designed impeller blades ensure high efficiency of the fan while keeping noise well under control. The impellers are dynamically balanced. Low weight and low moment of the impeller inertia help reduce the fan start-up time.
- The fan blades can be made of the following materials:
 - PAG – fiberglass reinforced polyamide
 - AL – aluminium
- Please confirm the blade material while placing your order.

Mounting

- The fans can be mounted on any flat surface or directly into a ventilation duct. The units are suitable for both horizontal and vertical configurations. In-duct installation requires flanges to attach the fan to the ductwork.
- To attach the fan to the floor, the wall or the ceiling use the O-AF carriers (not included as standard, should be purchased separately).
- The units are suitable for installation on rooftops to provide direct supply of outdoor air to the stairway areas.

Designation key

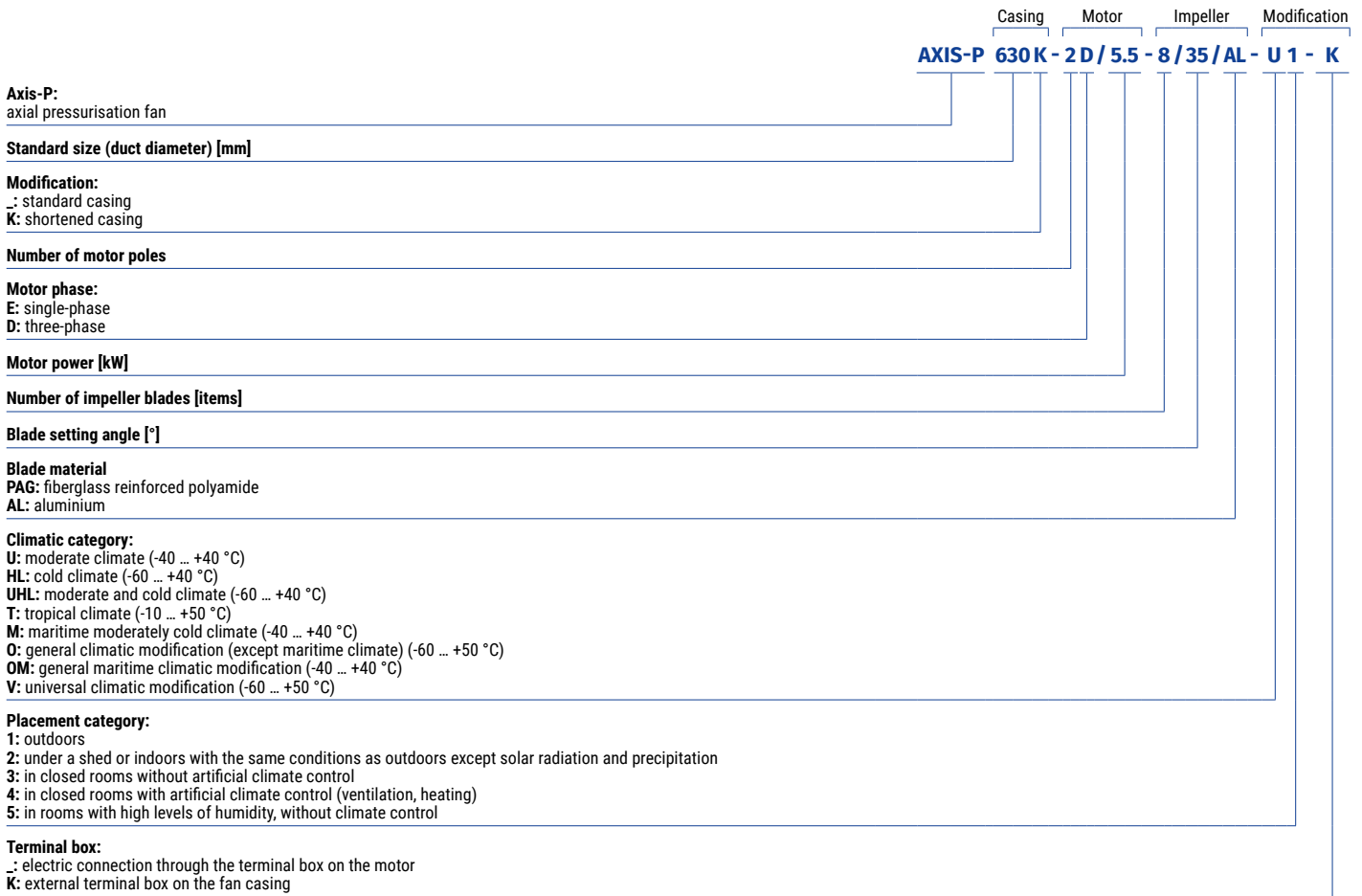

Technical data

AXIS-P 400-4

Size	Number of poles	Voltage [V/50 Hz]	Fan model with aluminum impeller (AL)	Fan model with fiberglass reinforced polyamide impeller (PAG)	Installed motor power Ny [kW]	RPM [min ⁻¹]	Number of blades	Blade setting angle [°]	Weight [kg]	Length L [mm]	Curve number on graph
400	4	3~400	Axis-P 400-4D/0.12-6/30/AL	Axis-P 400-4D/0.12-6/30/PAG	0.12	1440	6	30	19.5	350	①
			Axis-P 400-4D/0.18-6/35/AL	Axis-P 400-4D/0.18-6/35/PAG	0.18	1440	6	35	19.8	350	②
			Axis-P 400-4D/0.18-6/40/AL	Axis-P 400-4D/0.18-6/40/PAG	0.18	1440	6	40	19.8	350	③
			Axis-P 400-4D/0.25-6/45/AL	Axis-P 400-4D/0.25-6/45/PAG	0.25	1440	6	45	23.2	350	④
			Axis-P 400-4D/0.37-8/45/AL	Axis-P 400-4D/0.37-8/45/PAG	0.37	1440	8	45	23.9	350	⑤

Aerodynamic characteristics

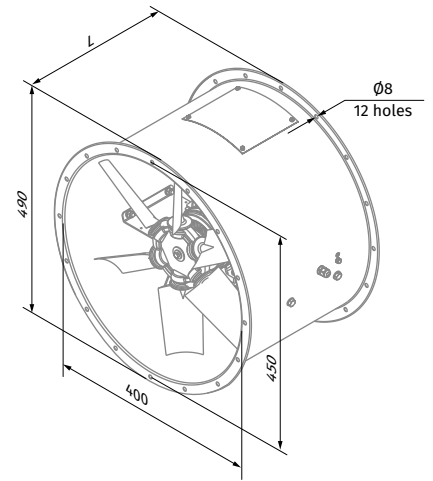
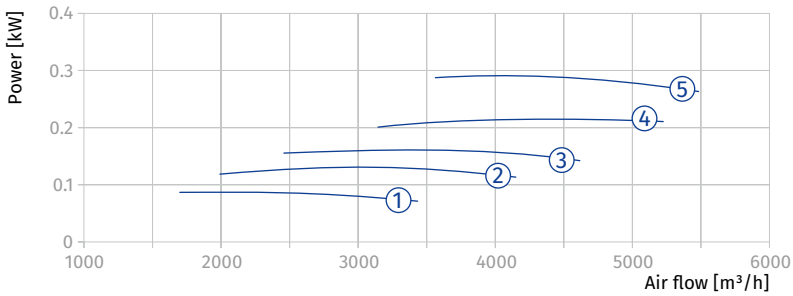
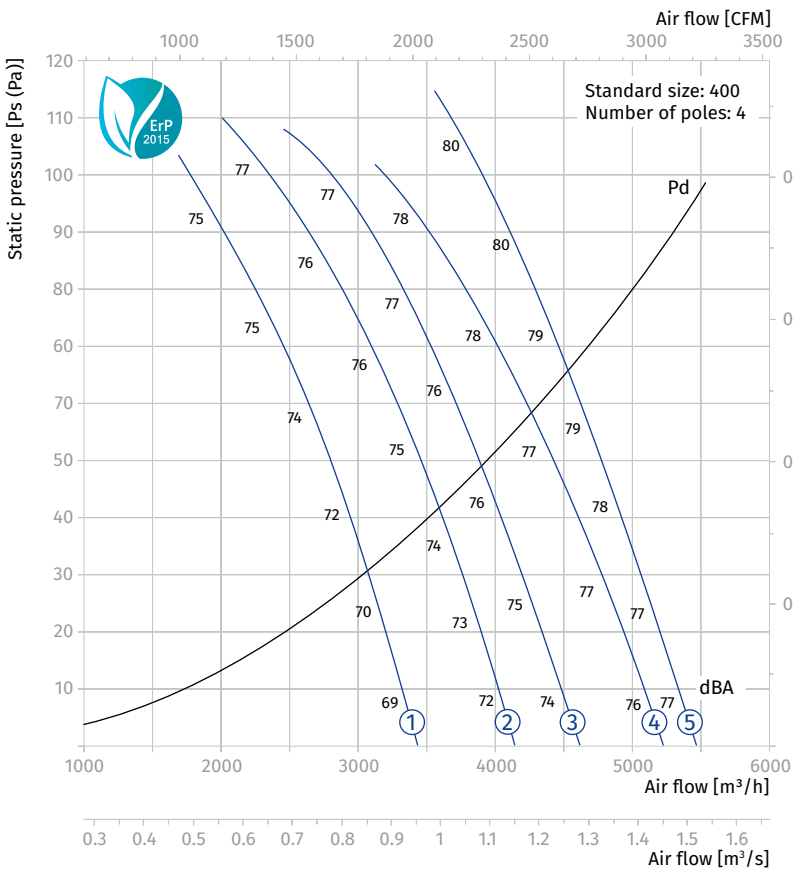

Axis-P 400-4

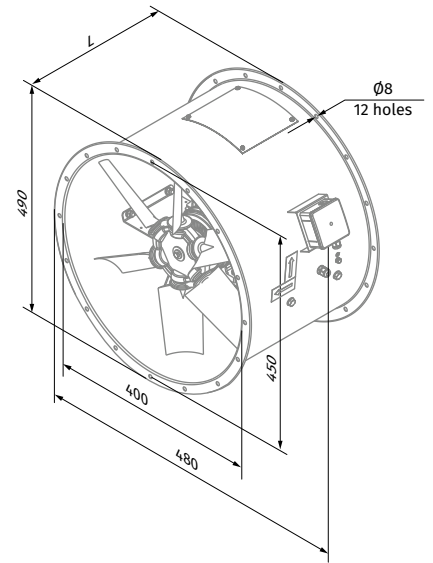

Axis-P 400-4...-K

Technical data

AXIS-P 400-2

Size	Number of poles	Voltage [V/50 Hz]	Fan model with aluminum impeller (AL)	Fan model with fiberglass reinforced polyamide impeller (PAG)	Installed motor power N_y [kW]	RPM [min ⁻¹]	Number of blades	Blade setting angle [°]	Weight [kg]	Length L [mm]	Curve number on graph
400	2	3~400	-	Axis-P 400-2D/0.55-6/25/PAG	0.55	2880	6	25	23.4	350	①
			Axis-P 400-2D/0.75-6/30/AL	Axis-P 400-2D/0.75-6/30/PAG	0.75	2880	6	30	26.5	350 (450*)	②
			Axis-P 400-2D/1.1-6/35/AL	Axis-P 400-2D/1.1-6/35/PAG	1.1	2880	6	35	27.0	450	③
			Axis-P 400-2D/1.5-6/40/AL	Axis-P 400-2D/1.5-6/40/PAG	1.5	2880	6	40	32.5	450	④
			Axis-P 400-2D/2.2-6/45/AL	Axis-P 400-2D/2.2-6/45/PAG	2.2	2880	6	45	34.5	450	⑤
			Axis-P 400-2D/2.2-8/45/AL	Axis-P 400-2D/2.2-8/45/PAG	2.2	2880	8	45	35.0	450	⑥

* Including a motor with energy efficiency IE3

Aerodynamic characteristics

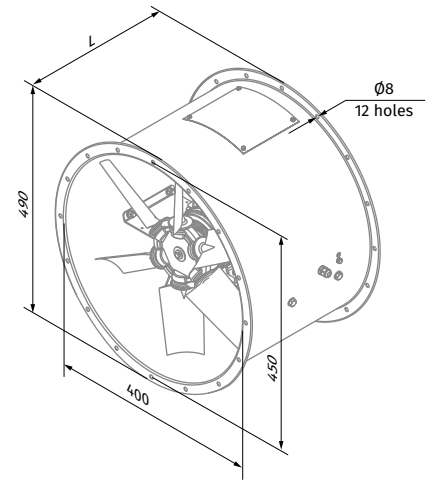
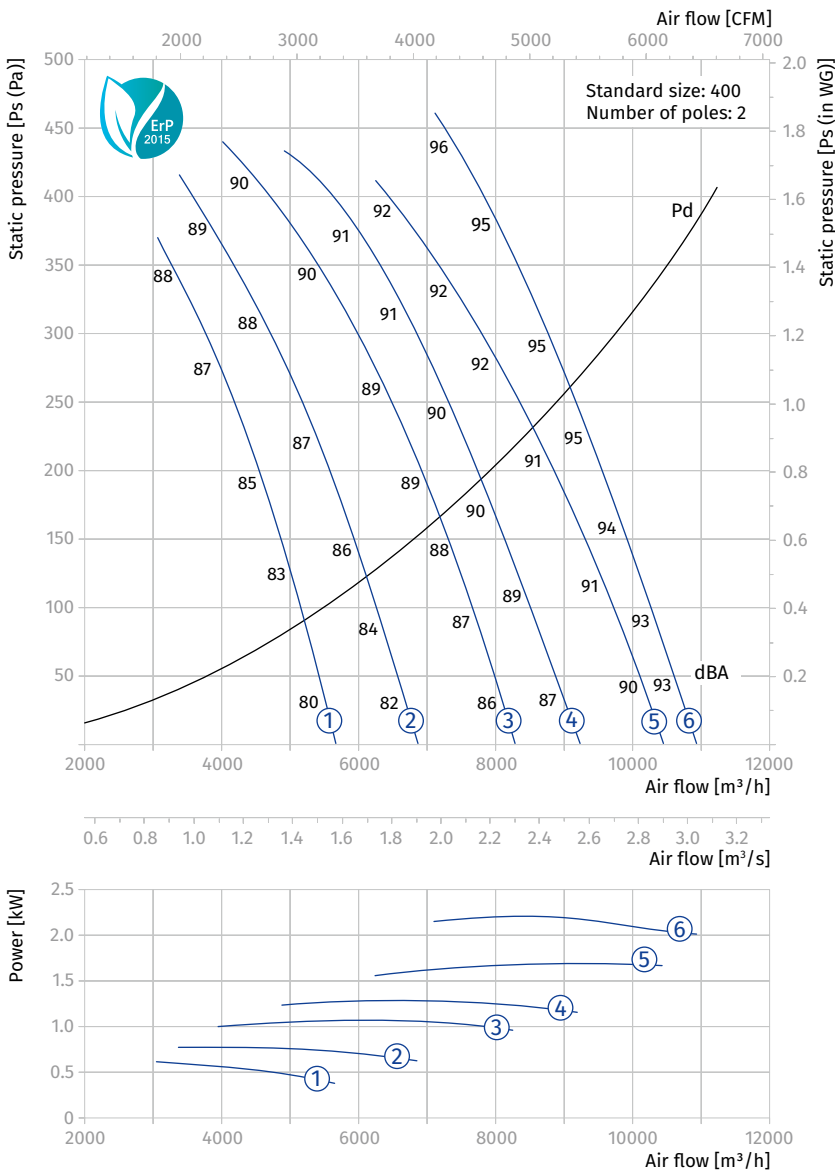

Axis-P 400-2

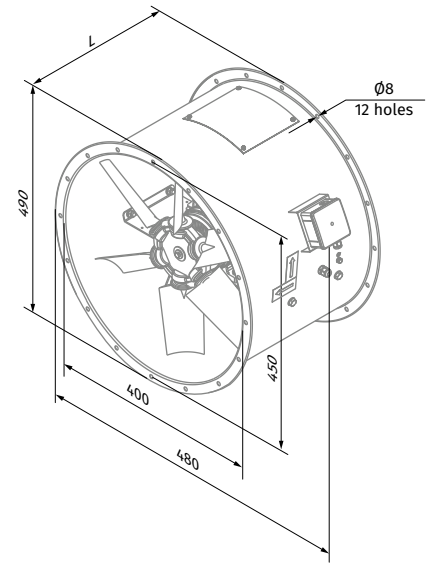

Axis-P 400-2...-K

AXIAL SMOKE EXTRACTION FANS

Technical data

AXIS-P 450-4

Size	Number of poles	Voltage [V/50 Hz]	Fan model with aluminum impeller (AL)	Fan model with fiberglass reinforced polyamide impeller (PAG)	Installed motor power Ny [kW]	RPM [min ⁻¹]	Number of blades	Blade setting angle [°]	Weight [kg]	Length L [mm]	Curve number on graph
450	4	3~400	-	Axis-P 450-4D/0.12-6/25/PAG	0.12	1440	6	25	29.1	350	①
			Axis-P 450-4D/0.18-6/30/AL	Axis-P 450-4D/0.18-6/30/PAG	0.18	1440	6	30	29.4	350	②
			Axis-P 450-4D/0.25-6/35/AL	Axis-P 450-4D/0.25-6/35/PAG	0.25	1440	6	35	32.8	350	③
			Axis-P 450-4D/0.25-6/40/AL	Axis-P 450-4D/0.25-6/40/PAG	0.25	1440	6	40	32.8	350	④
			Axis-P 450-4D/0.37-6/45/AL	Axis-P 450-4D/0.37-6/45/PAG	0.37	1440	6	45	33	350	⑤
			Axis-P 450-4D/0.55-8/45/AL	Axis-P 450-4D/0.55-8/45/PAG	0.55	1440	8	45	36.6	350 (450*)	⑥

* Including a motor with energy efficiency IE3

Aerodynamic characteristics

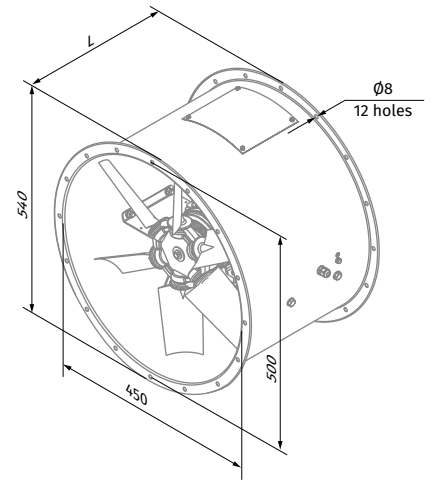
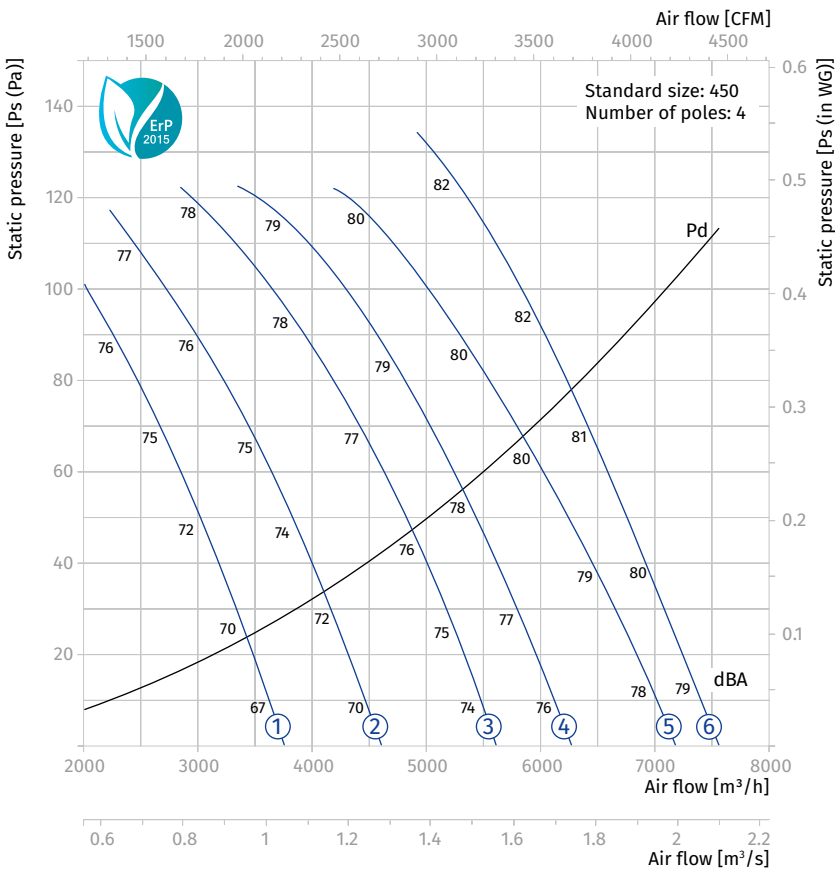

Axis-P 450-4

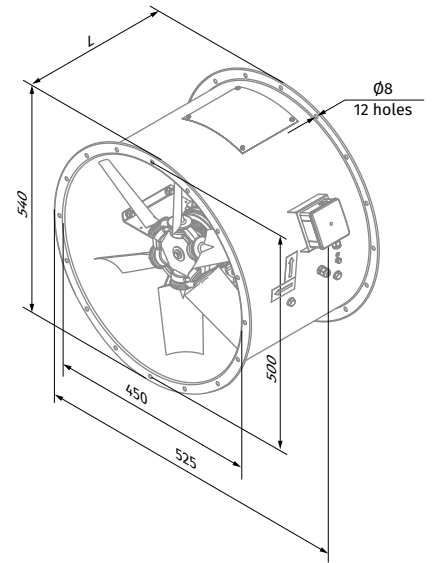

Axis-P 450-4...-K

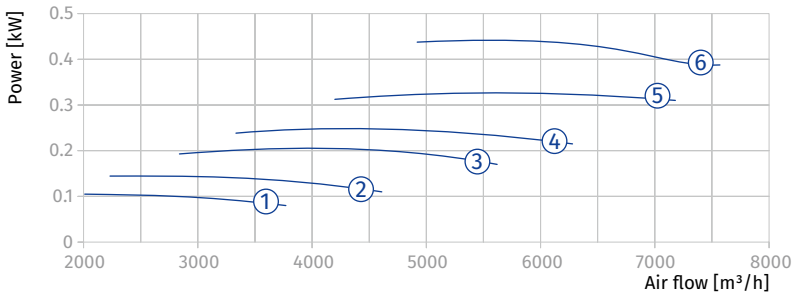

AXIAL SMOKE EXTRACTION FANS

Technical data

AXIS-P 450-2

Size	Number of poles	Voltage [V/50 Hz]	Fan model with aluminum impeller (AL)	Fan model with fiberglass reinforced polyamide impeller (PAG)	Installed motor power Ny [kW]	RPM [min ⁻¹]	Number of blades	Blade setting angle [°]	Weight [kg]	Length L [mm]	Curve number on graph
450	2	3~400	-	Axis-P 450-2D/0.75-6/25/PAG	0.75	2880	6	25	36.1	350 (450*)	①
			Axis-P 450-2D/1.1-6/30/AL	Axis-P 450-2D/1.1-6/30/PAG	1.1	2880	6	30	36.6	450	②
			Axis-P 450-2D/1.5-6/35/AL	Axis-P 450-2D/1.5-6/35/PAG	1.5	2880	6	35	42.1	450	③
			Axis-P 450-2D/2.2-6/40/AL	Axis-P 450-2D/2.2-6/40/PAG	2.2	2880	6	40	44.1	450	④
			Axis-P 450-2D/3-8/40/AL	Axis-P 450-2D/3-8/40/PAG	3	2880	8	40	53.6	450 (550*)	⑤
			Axis-P 450-2D/4-8/45/AL	Axis-P 450-2D/4-8/45/PAG	4	2880	8	45	63.7	550	⑥

* Including a motor with energy efficiency IE3

Aerodynamic characteristics

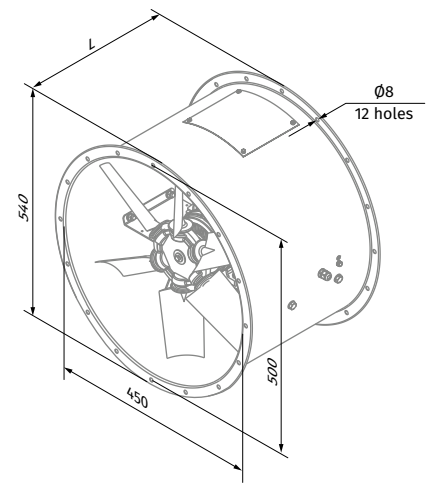
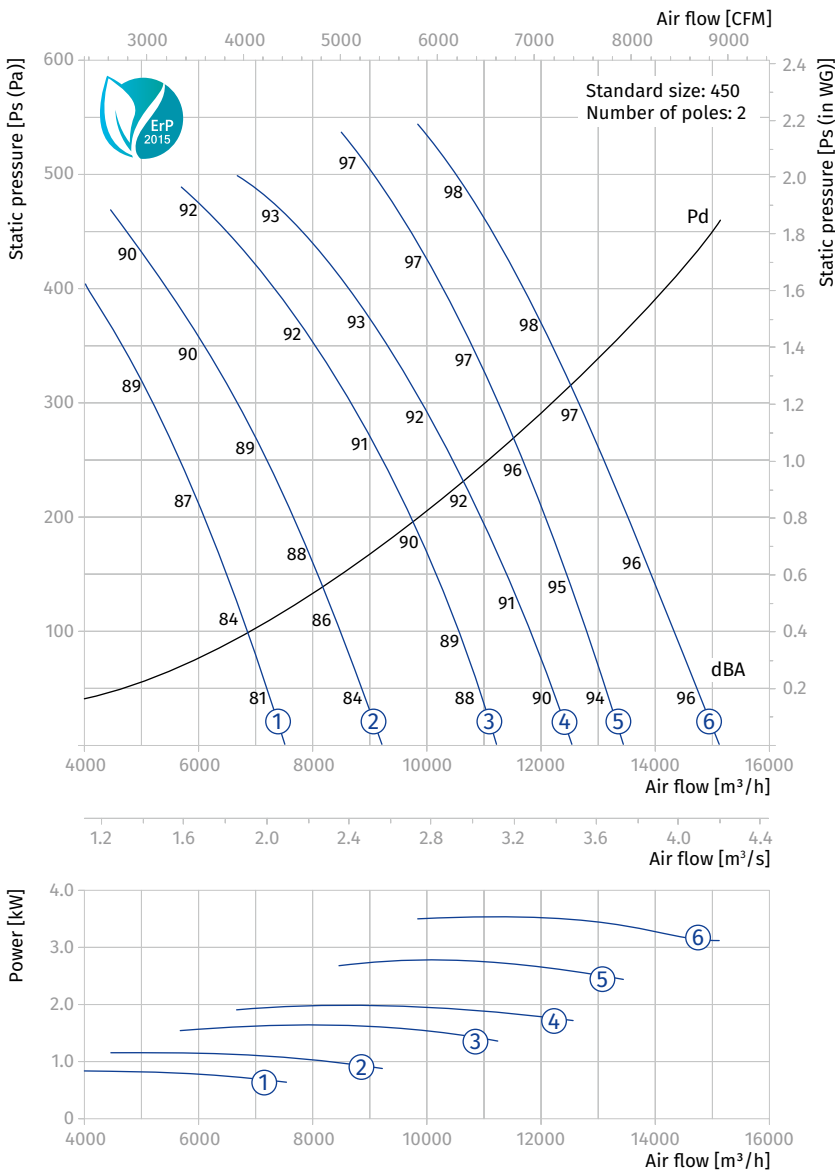

Axis-P 450-2

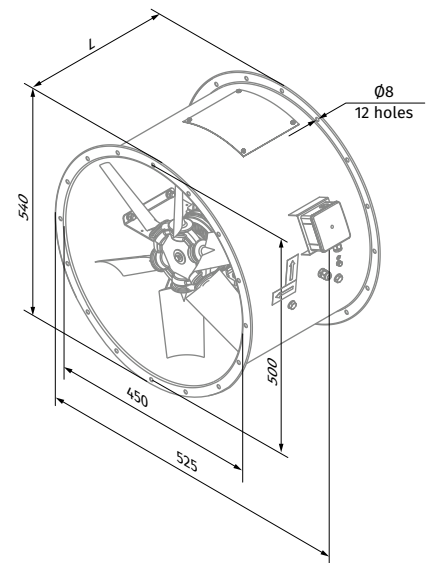

Axis-P 450-2...-K

AXIAL SMOKE EXTRACTION FANS

Technical data

AXIS-P 500-4

Size	Number of poles	Voltage [V/50 Hz]	Fan model with aluminum impeller (AL)	Fan model with fiberglass reinforced polyamide impeller (PAG)	Installed motor power Ny [kW]	RPM [min ⁻¹]	Number of blades	Blade setting angle [°]	Weight [kg]	Length L [mm]	Curve number on graph
500	4	3~400	-	Axis-P 500-4D/0.18-6/25/PAG	0.18	1440	6	25	61.5	350	①
			Axis-P 500-4D/0.25-6/30/AL	Axis-P 500-4D/0.25-6/30/PAG	0.25	1440	6	30	61.7	350	②
			Axis-P 500-4D/0.37-6/35/AL	Axis-P 500-4D/0.37-6/35/PAG	0.37	1440	6	35	64.8	350	③
			Axis-P 500-4D/0.37-6/40/AL	Axis-P 500-4D/0.37-6/40/PAG	0.37	1440	6	40	64.8	350	④
			Axis-P 500-4D/0.55-6/45/AL	Axis-P 500-4D/0.55-6/45/PAG	0.55	1440	6	45	65.6	450	⑤
			Axis-P 500-4D/0.75-8/45/AL	Axis-P 500-4D/0.75-8/45/PAG	0.75	1440	8	45	71.4	450	⑥

* Including a motor with energy efficiency IE3

Aerodynamic characteristics

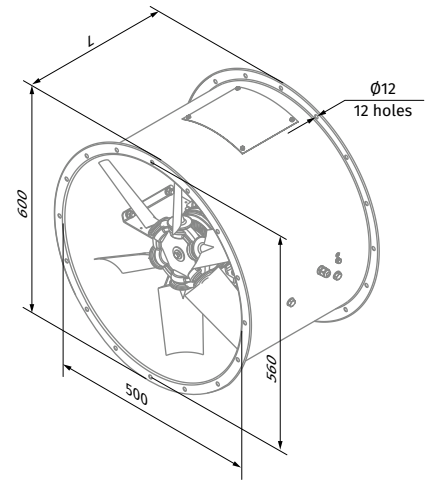
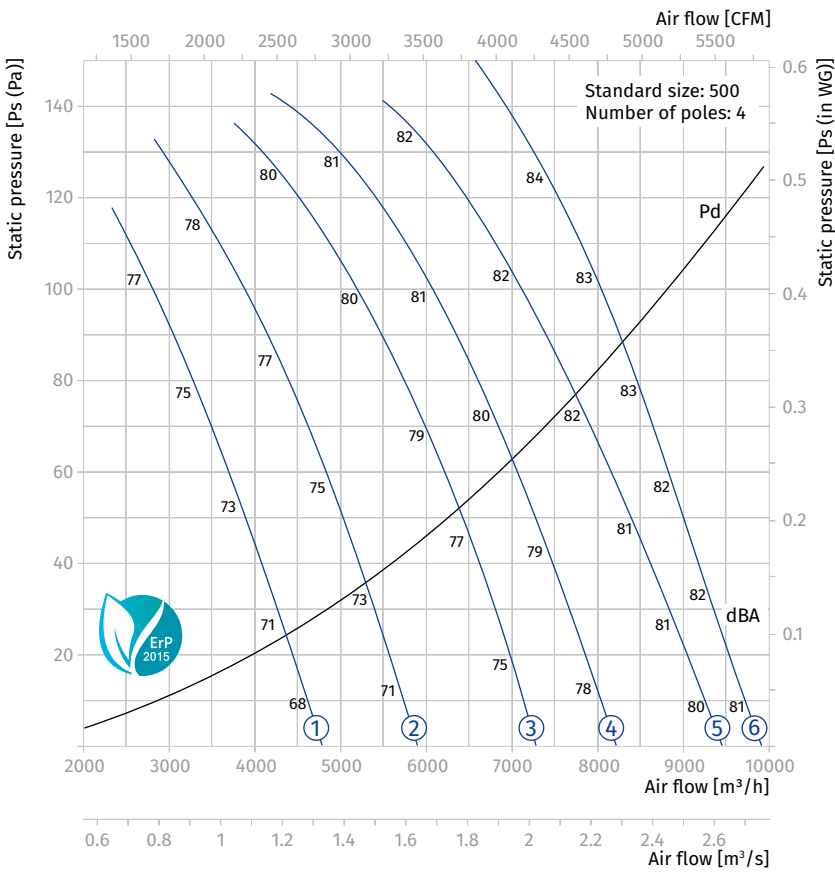

Axis-P 500-4

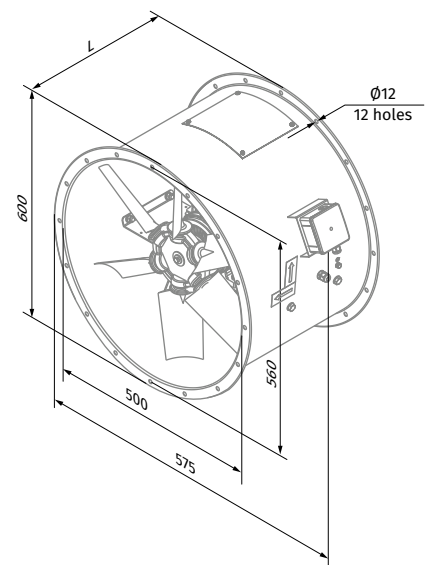

Axis-P 500-4...-K

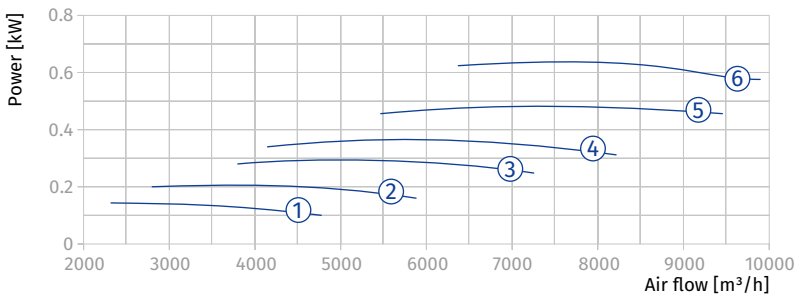

Technical data

AXIS-P 500-2

Size	Number of poles	Voltage [V/50 Hz]	Fan model with aluminum impeller (AL)	Fan model with fiberglass reinforced polyamide impeller (PAG)	Installed motor power N_y [kW]	RPM [min ⁻¹]	Number of blades	Blade setting angle [°]	Weight [kg]	Length L [mm]	Curve number on graph
500	2	3~400	-	Axis-P 500-2D/1.1-6/25/PAG	1.1	2880	6	25	48.2	450	①
			Axis-P 500-2D/1.5-6/30/AL	Axis-P 500-2D/1.5-6/30/PAG	1.5	2880	6	30	53.7	450	②
			Axis-P 500-2D/2.2-6/35/AL	Axis-P 500-2D/2.2-6/35/PAG	2.2	2880	6	35	55.7	450	③
			Axis-P 500-2D/3-8/35/AL	Axis-P 500-2D/3-8/35/PAG	3	2880	8	35	65.3	450 (550*)	④
			Axis-P 500-2D/4-8/40/AL	Axis-P 500-2D/4-8/40/PAG	4	2880	8	40	75.4	550	⑤
			Axis-P 500-2D/5.5-8/45/AL	Axis-P 500-2D/5.5-8/45/PAG	5.5	2880	8	45	96.8	550	⑥

* Including a motor with energy efficiency IE3

Aerodynamic characteristics

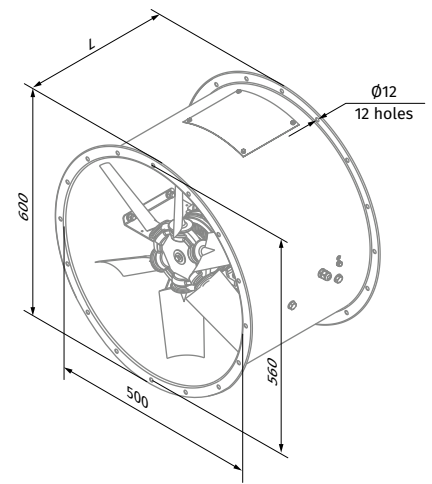
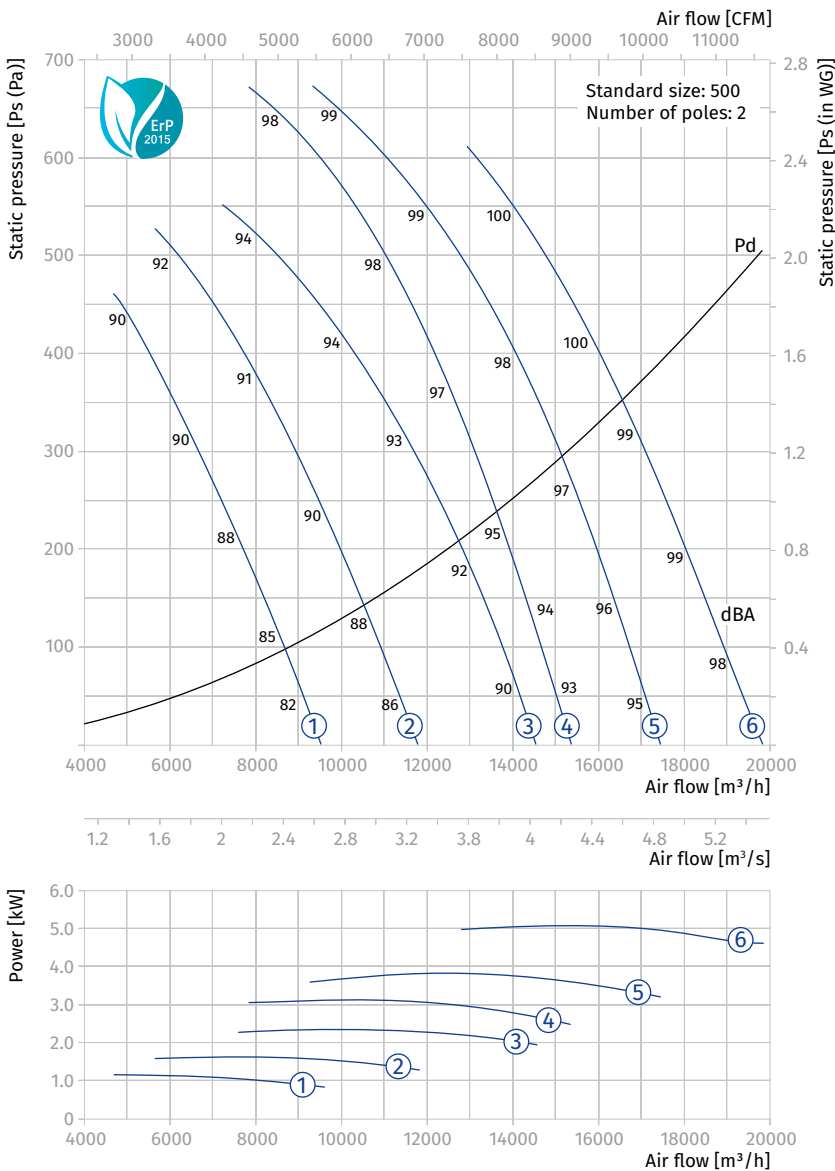

Axis-P 500-2

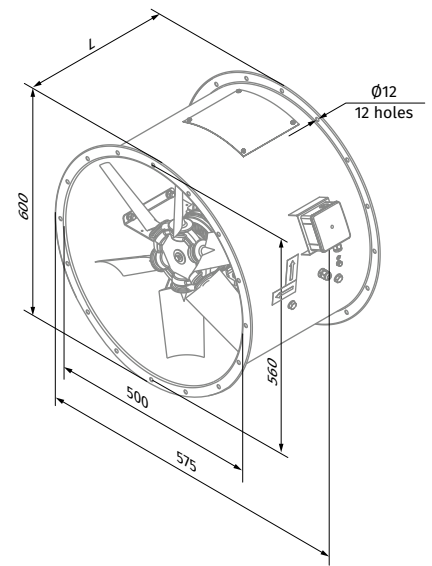

Axis-P 500-2...-K

AXIAL SMOKE EXTRACTION FANS

Technical data

AXIS-P 560-4

Size	Number of poles	Voltage [V/50 Hz]	Fan model with aluminum impeller (AL)	Fan model with fiberglass reinforced polyamide impeller (PAG)	Installed motor power Ny [kW]	RPM [min ⁻¹]	Number of blades	Blade setting angle [°]	Weight [kg]	Length L [mm]	Curve number on graph
560	4	3~400	-	Axis-P 560-4D/0.25-6/25/PAG	0.25	1440	6	25	61.5	350	①
			Axis-P 560-4D/0.37-6/30/AL	Axis-P 560-4D/0.37-6/30/PAG	0.37	1440	6	30	61.7	350	②
			Axis-P 560-4D/0.55-6/35/AL	Axis-P 560-4D/0.55-6/35/PAG	0.55	1440	6	35	64.8	350 (450*)	③
			Axis-P 560-4D/0.55-6/40/AL	Axis-P 560-4D/0.55-6/40/PAG	0.55	1440	6	40	64.8	350 (450*)	④
			Axis-P 560-4D/0.75-6/45/AL	Axis-P 560-4D/0.75-6/45/PAG	0.75	1440	6	45	65.6	450	⑤
			Axis-P 560-4D/1.1-8/45/AL	Axis-P 560-4D/1.1-8/45/PAG	1.1	1440	8	45	71.4	450	⑥

* Including a motor with energy efficiency IE3

Aerodynamic characteristics

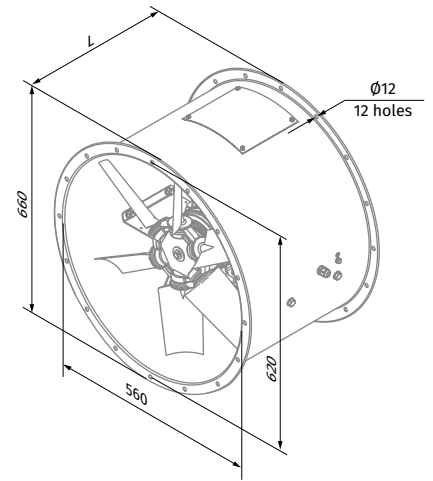
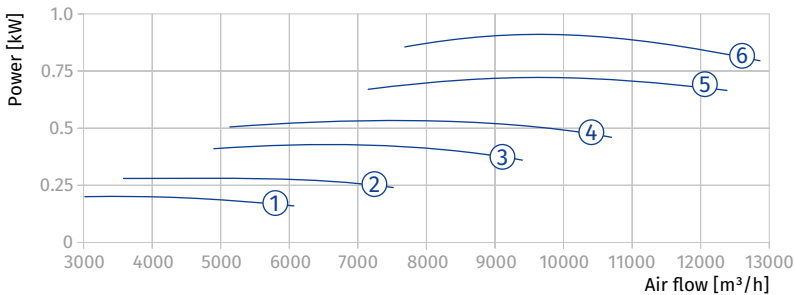
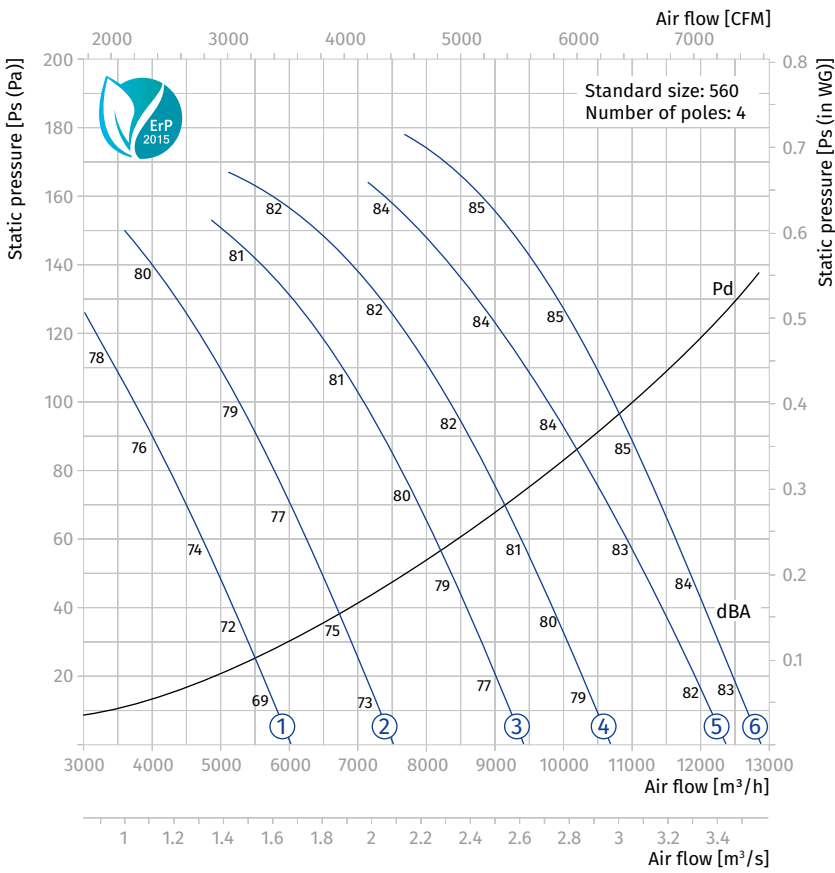

Axis-P 560-4

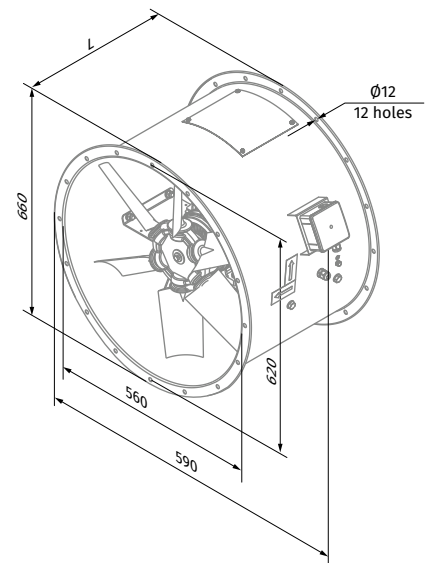

Axis-P 560-4...-K

Technical data

AXIS-P 560-2

Size	Number of poles	Voltage [V/50 Hz]	Fan model with aluminum impeller (AL)	Fan model with fiberglass reinforced polyamide impeller (PAG)	Installed motor power N_y [kW]	RPM [min ⁻¹]	Number of blades	Blade setting angle [°]	Weight [kg]	Length L [mm]	Curve number on graph
560	2	3~400	-	Axis-P 560-2D/1.5-6/25/PAG	1.5	2880	6	25	70.8	450	①
			Axis-P 560-2D/2.2-6/30/AL	Axis-P 560-2D/2.2-6/30/PAG	2.2	2880	6	30	72.8	450	②
			Axis-P 560-2D/3-8/30/AL	Axis-P 560-2D/3-8/30/PAG	3	2880	8	30	82.4	450 (550*)	③
			Axis-P 560-2D/4-8/35/AL	Axis-P 560-2D/4-8/35/PAG	4	2880	8	35	92.5	550	④
			Axis-P 560-2D/5.5-8/40/AL	Axis-P 560-2D/5.5-8/40/PAG	5.5	2880	8	40	113.9	550	⑤
			Axis-P 560-2D/7.5-8/45/AL	Axis-P 560-2D/7.5-8/45/PAG	7.5	2880	8	45	117.9	550 (650*)	⑥

* Including a motor with energy efficiency IE3

Aerodynamic characteristics

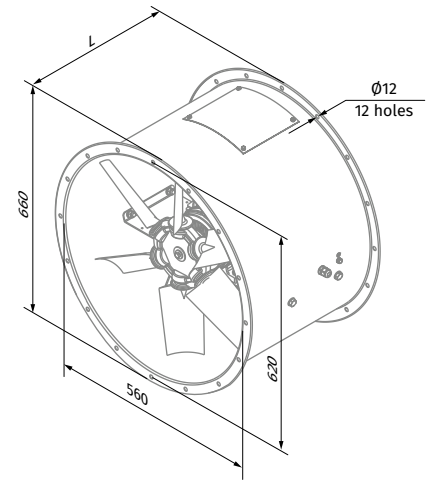
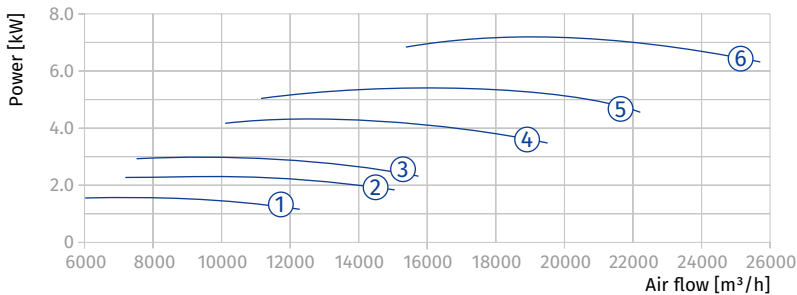
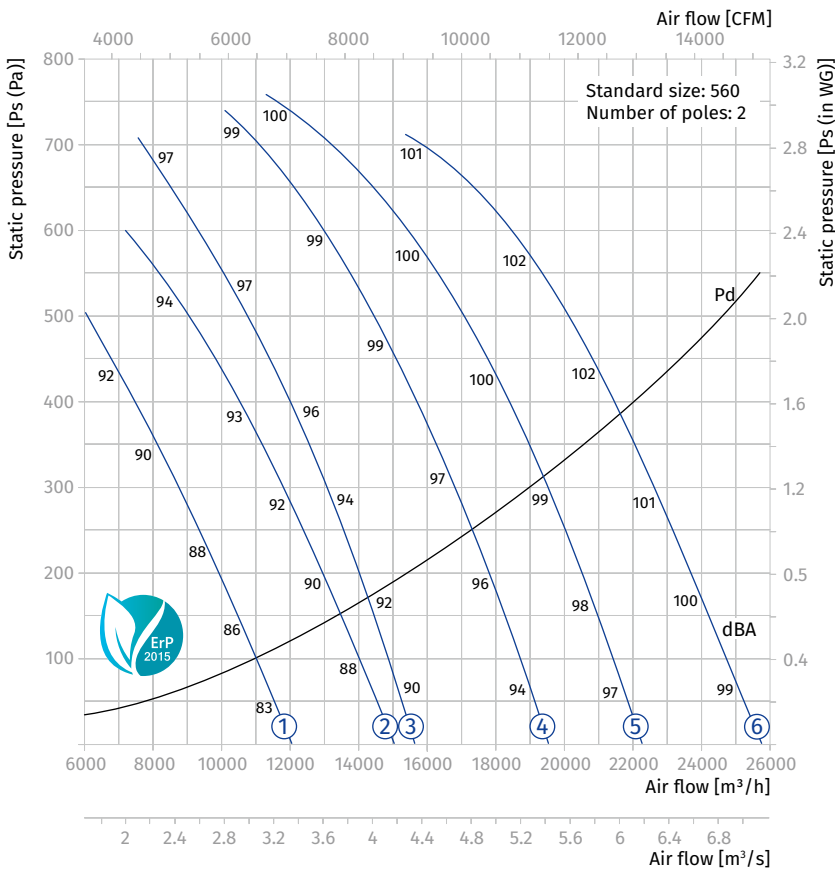

Axis-P 560-2

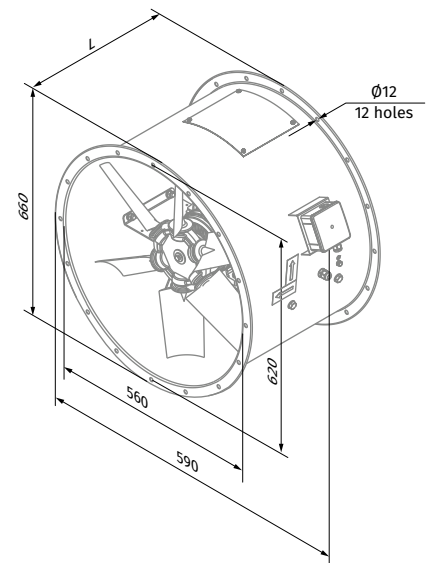

Axis-P 560-2...-K

AXIAL SMOKE EXTRACTION FANS

Technical data

AXIS-P 630-4

Size	Number of poles	Voltage [V/50 Hz]	Fan model with aluminum impeller (AL)	Fan model with fiberglass reinforced polyamide impeller (PAG)	Installed motor power Ny [kW]	RPM [min ⁻¹]	Number of blades	Blade setting angle [°]	Weight [kg]	Length L [mm]	Curve number on graph
630	4	3~400	-	Axis-P 630-4D/0.37-8/25/PAG	0.37	1440	8	25	67.9	350	①
			Axis-P 630-4D/0.55-8/30/AL	Axis-P 630-4D/0.55-8/30/PAG	0.55	1440	8	30	71	350 (450*)	②
			Axis-P 630-4D/0.75-8/35/AL	Axis-P 630-4D/0.75-8/35/PAG	0.75	1440	8	35	71.8	450	③
			Axis-P 630-4D/1.1-8/40/AL	Axis-P 630-4D/1.1-8/40/PAG	1.1	1440	8	40	77	450	④
			Axis-P 630-4D/1.5-6/32.5/AL	Axis-P 630-4D/1.5-6/32.5/PAG	1.5	1440	6	32.5	81.1	450	⑤
			Axis-P 630-4D/1.5-8/45/AL	Axis-P 630-4D/1.5-8/45/PAG	1.5	1440	8	45	80	450	⑥
			Axis-P 630-4D/1.5-6/37.5/AL	Axis-P 630-4D/1.5-6/37.5/PAG	1.5	1440	6	37.5	81.1	450	⑦
			Axis-P 630-4D/2.2-6/40/AL	Axis-P 630-4D/2.2-6/40/PAG	2.2	1440	6	40	83.2	450 (550*)	⑧
			Axis-P 630-4D/2.2-6/45/AL	Axis-P 630-4D/2.2-6/45/PAG	2.2	1440	6	45	83.2	450 (550*)	⑨

* Including a motor with energy efficiency IE3

Aerodynamic characteristics

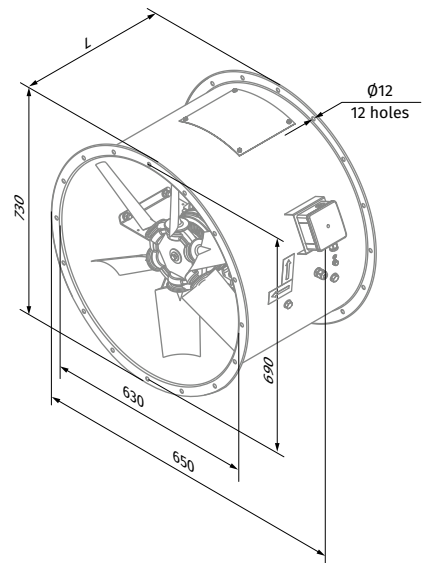
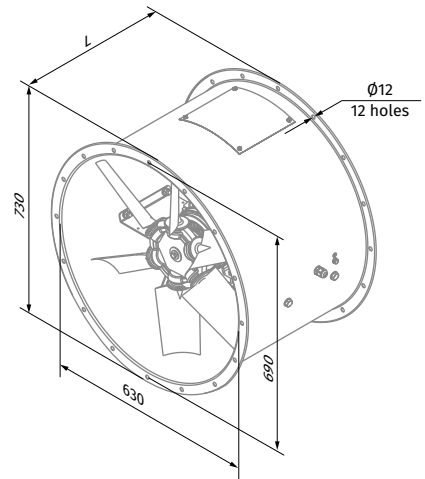
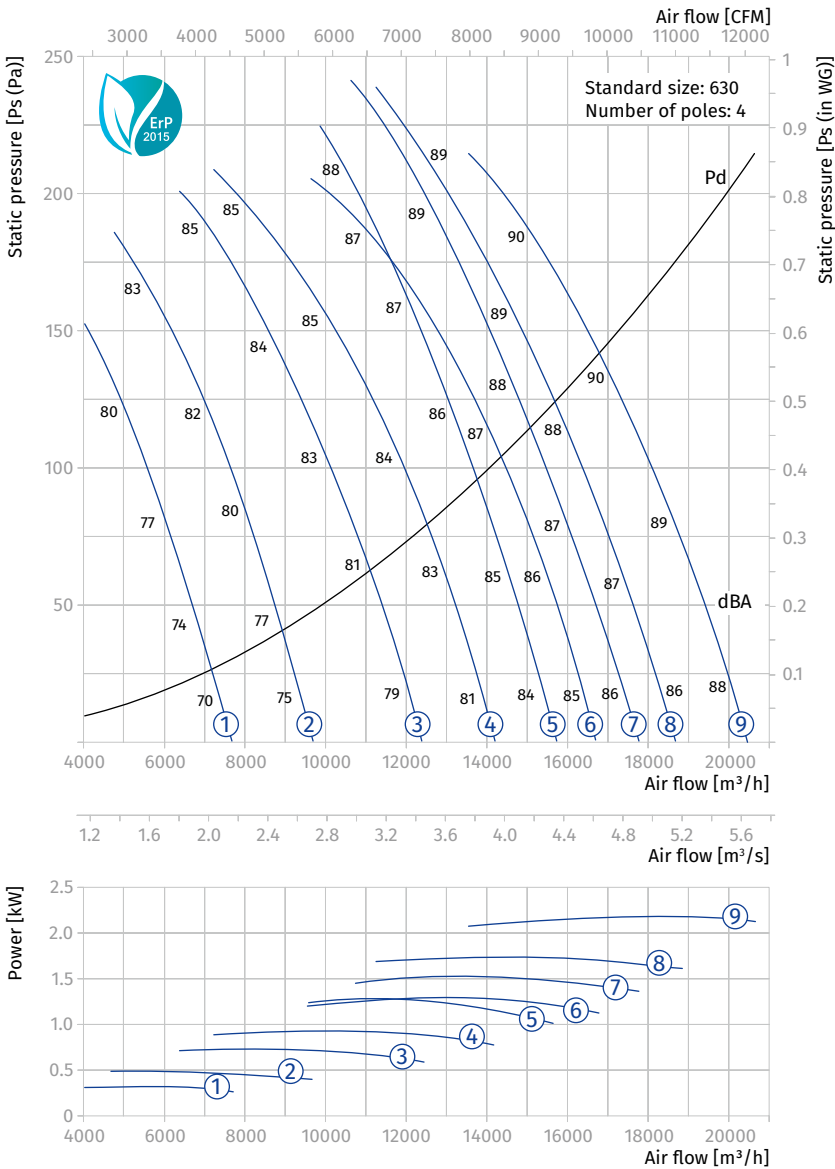

Technical data

AXIS-P 630-2

Size	Number of poles	Voltage [V/50 Hz]	Fan model with aluminum impeller (AL)	Fan model with fiberglass reinforced polyamide impeller (PAG)	Installed motor power N_y [kW]	RPM [min ⁻¹]	Number of blades	Blade setting angle [°]	Weight [kg]	Length L [mm]	Curve number on graph
630	2	3~400	-	Axis-P 630-2D/3-8/25/PAG	3	2880	8	25	88	450 (550*)	①
			Axis-P 630-2D/4-8/30/AL	Axis-P 630-2D/4-8/30/PAG	4	2880	8	30	98.1	550	②
			Axis-P 630-2D/5.5-8/35/AL	Axis-P 630-2D/5.5-8/35/PAG	5.5	2880	8	35	119.5	550	③
			Axis-P 630-2D/7.5-8/40/AL	Axis-P 630-2D/7.5-8/40/PAG	7.5	2880	8	40	123.5	550 (650*)	④
			Axis-P 630-2D/9.2-6/30/AL	Axis-P 630-2D/9.2-6/30/PAG	9.2	2880	6	30	130.1	650	⑤
			Axis-P 630-2D/11-6/32.5/AL	Axis-P 630-2D/11-6/32.5/PAG	11	2880	6	32.5	154.1	650 (750*)	⑥
			Axis-P 630-2D/11-6/35/AL	Axis-P 630-2D/11-6/35/PAG	11	2880	6	35	154.1	650 (750*)	⑦
			Axis-P 630-2D/15-6/37.5/AL	Axis-P 630-2D/15-6/37.5/PAG	15	2880	6	37.5	166.7	750	⑧
			Axis-P 630-2D/15-6/40/AL	Axis-P 630-2D/15-6/40/PAG	15	2880	6	40	166.7	750	⑨
			Axis-P 630-2D/18.5-6/45/AL	Axis-P 630-2D/18.5-6/45/PAG	18.5	2880	6	45	179.8	750	⑩

* Including a motor with energy efficiency IE3

Aerodynamic characteristics

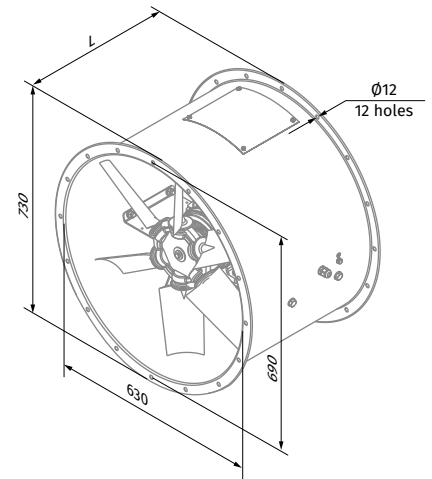
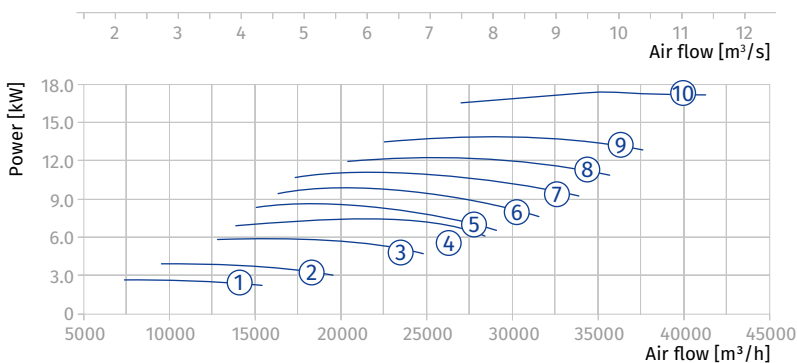
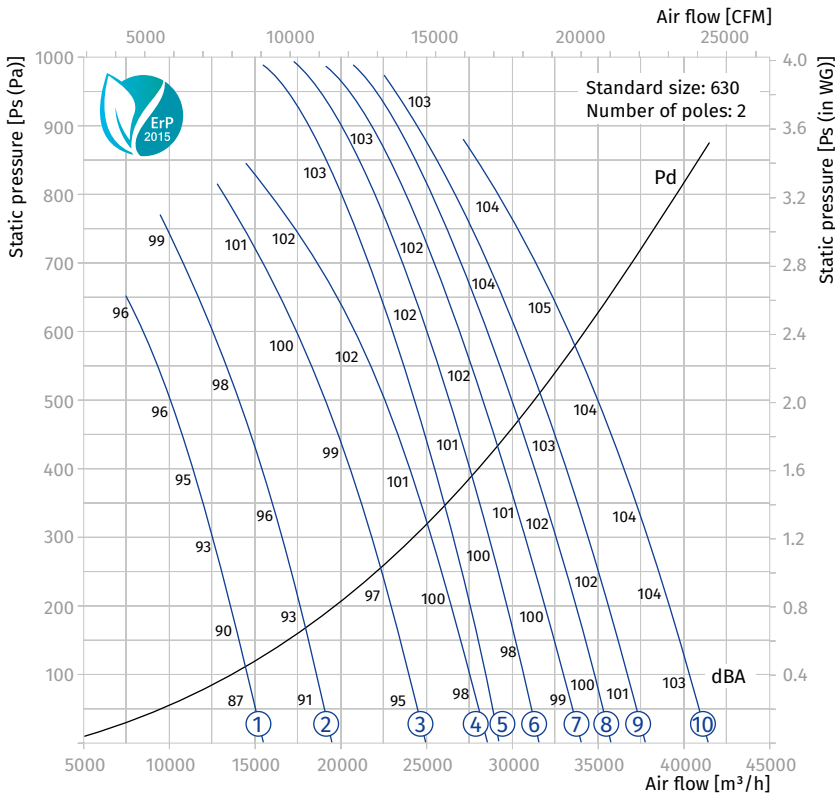

Axis-P 630-2

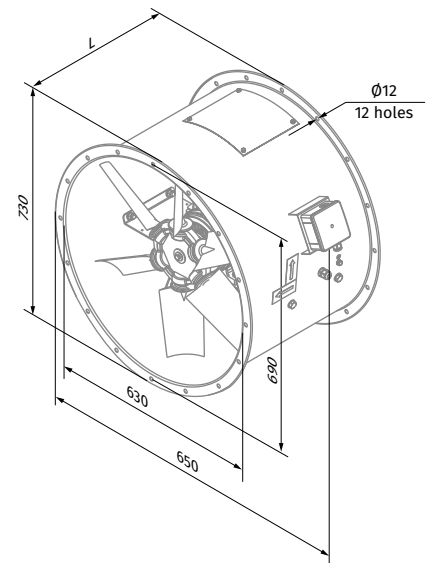

Axis-P 630-2...-K

AXIAL SMOKE EXTRACTION FANS

Technical data

AXIS-P 710-4

Size	Number of poles	Voltage [V/50 Hz]	Fan model with aluminum impeller (AL)	Fan model with fiberglass reinforced polyamide impeller (PAG)	Installed motor power Ny [kW]	RPM [min ⁻¹]	Number of blades	Blade setting angle [°]	Weight [kg]	Length L [mm]	Curve number on graph
710	4	3~400	Axis-P 710-4D/0.75-6/20/AL	Axis-P 710-4D/0.75-6/20/PAG	0.75	1440	6	20	99.1	450	①
			Axis-P 710-4D/1.1-6/25/AL	Axis-P 710-4D/1.1-6/25/PAG	1.1	1440	6	25	104.3	450	②
			Axis-P 710-4D/1.5-6/30/AL	Axis-P 710-4D/1.5-6/30/PAG	1.5	1440	6	30	107.3	450	③
			Axis-P 710-4D/2.2-6/32.5/AL	Axis-P 710-4D/2.2-6/32.5/PAG	2.2	1440	6	32.5	109.4	450 (550*)	④
			Axis-P 710-4D/2.2-6/35/AL	Axis-P 710-4D/2.2-6/35/PAG	2.2	1440	6	35	109.4	450 (550*)	⑤
			Axis-P 710-4D/2.2-6/37.5/AL	Axis-P 710-4D/2.2-6/37.5/PAG	2.2	1440	6	37.5	109.4	450 (550*)	⑥
			Axis-P 710-4D/3-6/40/AL	Axis-P 710-4D/3-6/40/PAG	3	1440	6	40	118.3	550	⑦
			Axis-P 710-4D/4-6/45/AL	Axis-P 710-4D/4-6/45/PAG	4	1440	6	45	129.4	550	⑧

* Including a motor with energy efficiency IE3

Aerodynamic characteristics

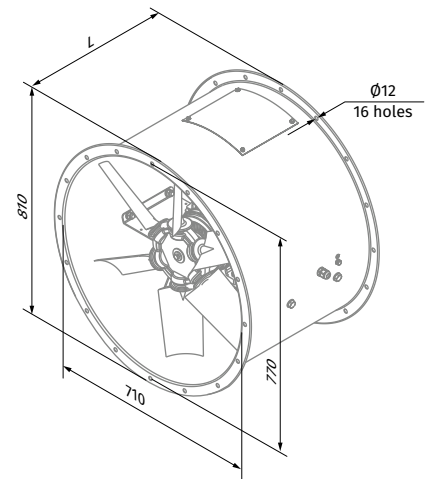
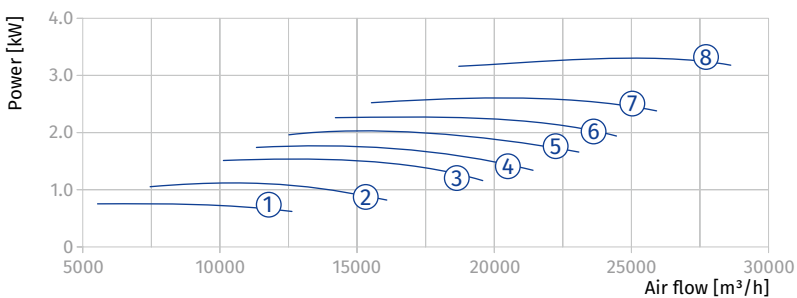
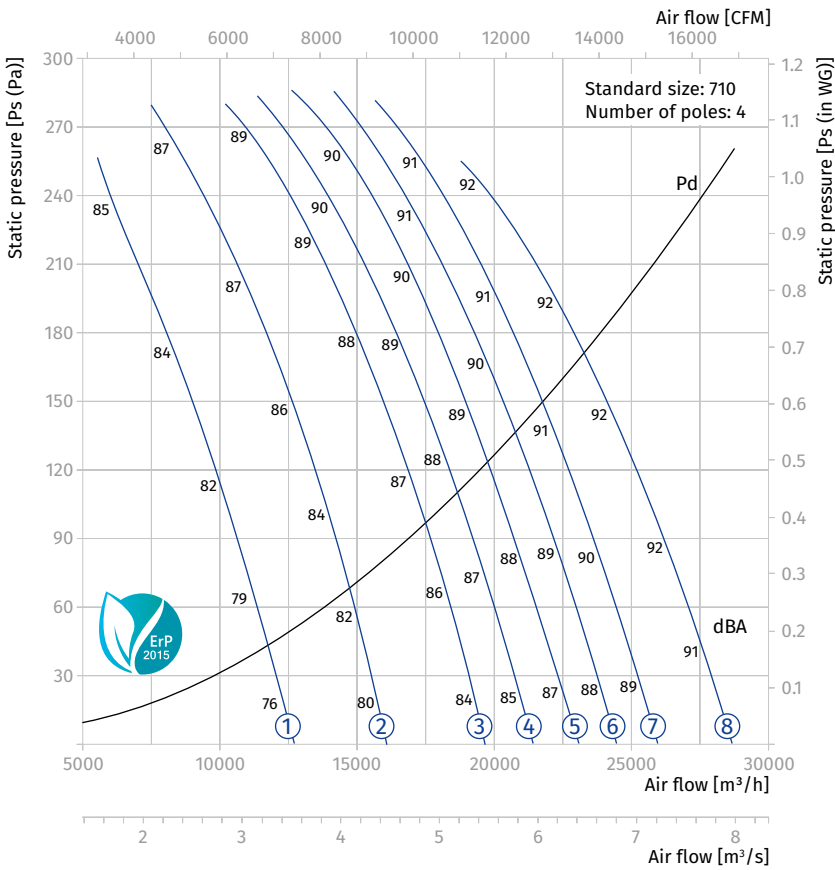

Axis-P 710-4

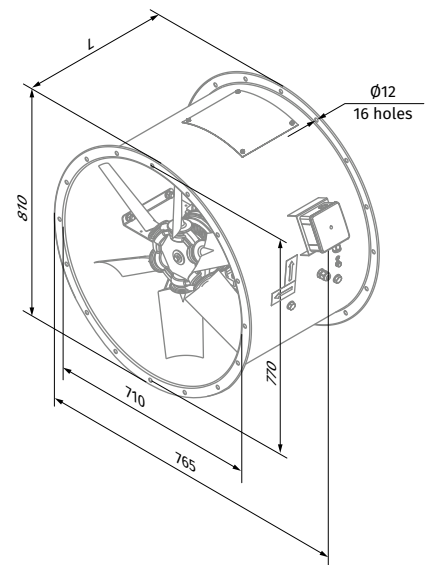

Axis-P 710-4...-K

Technical data

AXIS-P 710-2

Size	Number of poles	Voltage [V/50 Hz]	Fan model with aluminum impeller (AL)	Fan model with fiberglass reinforced polyamide impeller (PAG)	Installed motor power N_y [kW]	RPM [min ⁻¹]	Number of blades	Blade setting angle [°]	Weight [kg]	Length L [mm]	Curve number on graph
710	2	3~400	Axis-P 710-2D/7.5-6/20/AL	Axis-P 710-2D/7.5-6/20/PAG	7.5	2880	6	20	150.8	550 (650*)	①
			Axis-P 710-2D/9.2-6/25/AL	Axis-P 710-2D/9.2-6/25/PAG	9.2	2880	6	25	156.3	650	②
			Axis-P 710-2D/15-6/30/AL	Axis-P 710-2D/15-6/30/PAG	15	2880	6	30	192.9	750	③
			Axis-P 710-2D/15-6/32.5/AL	Axis-P 710-2D/15-6/32.5/PAG	15	2880	6	32.5	192.9	750	④
			Axis-P 710-2D/18.5-6/35/AL	Axis-P 710-2D/18.5-6/35/PAG	18.5	2880	6	35	206	750	⑤
			Axis-P 710-2D/18.5-6/37.5/AL	Axis-P 710-2D/18.5-6/37.5/PAG	18.5	2880	6	37.5	206	750	⑥
			Axis-P 710-2D/22-6/40/AL	Axis-P 710-2D/22-6/40/PAG	22	2880	6	40	246	850	⑦

* Including a motor with energy efficiency IE3

Aerodynamic characteristics

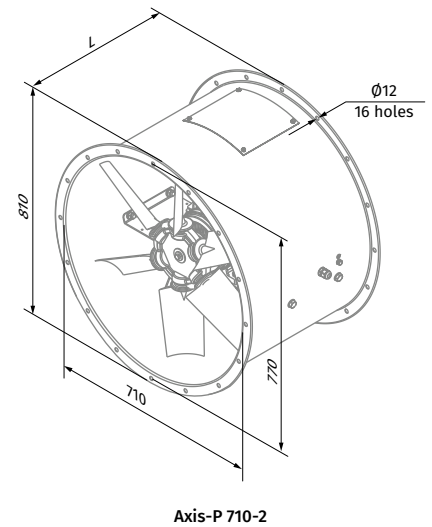
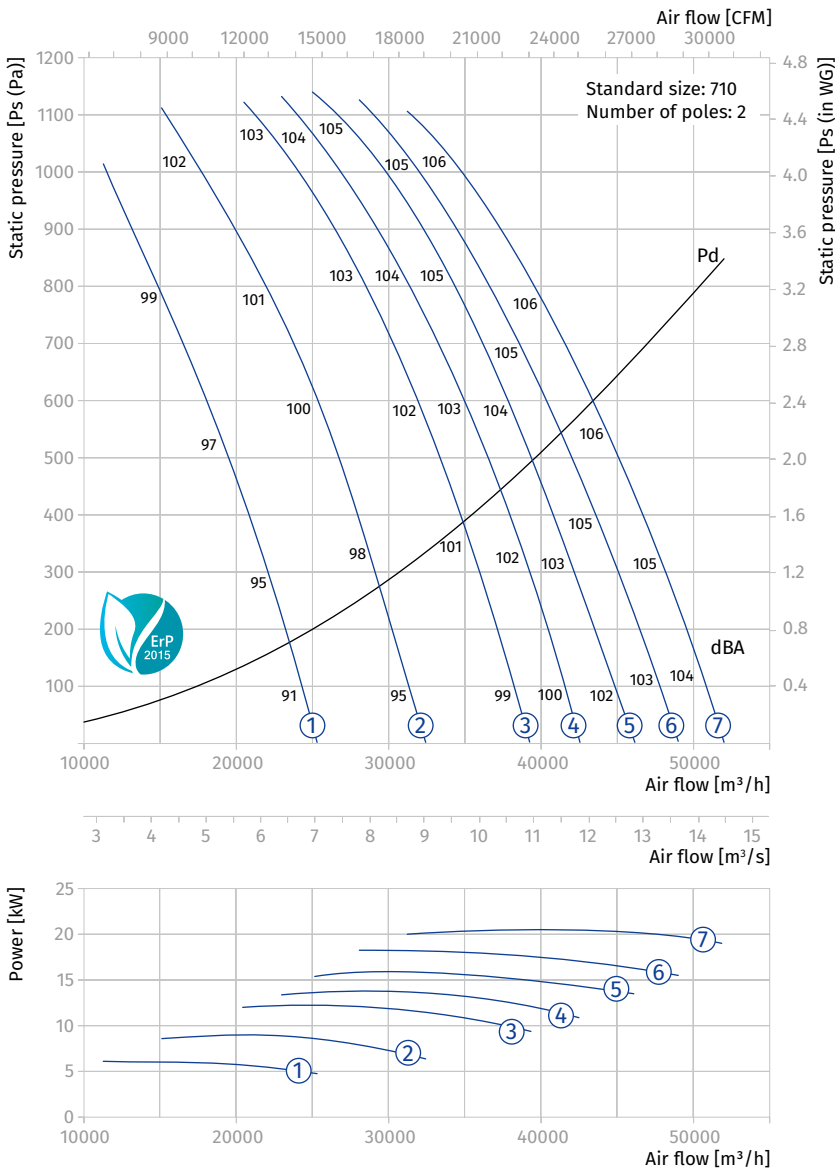

Axis-P 710-2

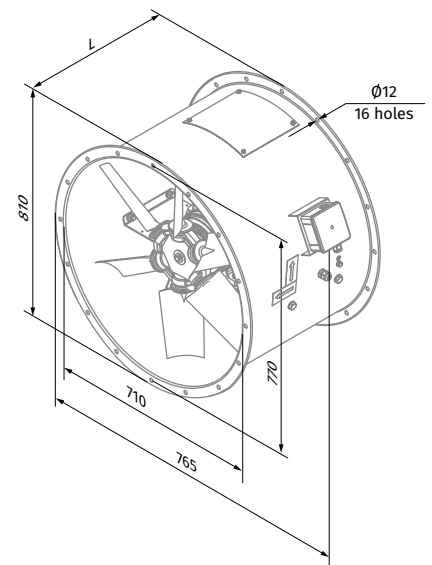

Axis-P 710-2...-K

AXIAL SMOKE EXTRACTION FANS

Technical data

AXIS-P 800-6

Size	Number of poles	Voltage [V/50 Hz]	Fan model with aluminum impeller (AL)	Fan model with fiberglass reinforced polyamide impeller (PAG)	Installed motor power Ny [kW]	RPM [min ⁻¹]	Number of blades	Blade setting angle [°]	Weight [kg]	Length L [mm]	Curve number on graph
800	6	3~400	Axis-P 800-6D/0.37-6/20/AL	Axis-P 800-6D/0.37-6/20/PAG	0.37	960	6	20	109.6	450	①
			Axis-P 800-6D/0.55-6/25/AL	Axis-P 800-6D/0.55-6/25/PAG	0.55	960	6	25	111.1	450	②
			Axis-P 800-6D/0.75-6/30/AL	Axis-P 800-6D/0.75-6/30/PAG	0.75	960	6	30	116.4	450	③
			Axis-P 800-6D/0.75-6/32.5/AL	Axis-P 800-6D/0.75-6/32.5/PAG	0.75	960	6	32.5	116.4	450	④
			Axis-P 800-6D/1.1-6/35/AL	Axis-P 800-6D/1.1-6/35/PAG	1.1	960	6	35	116.5	450	⑤
			Axis-P 800-6D/1.1-6/37.5/AL	Axis-P 800-6D/1.1-6/37.5/PAG	1.1	960	6	37.5	116.5	450	⑥
			Axis-P 800-6D/1.1-6/40/AL	Axis-P 800-6D/1.1-6/40/PAG	1.1	960	6	40	116.5	450	⑦
			Axis-P 800-6D/1.5-6/45/AL	Axis-P 800-6D/1.5-6/45/PAG	1.5	960	6	45	124.6	550	⑧

Aerodynamic characteristics

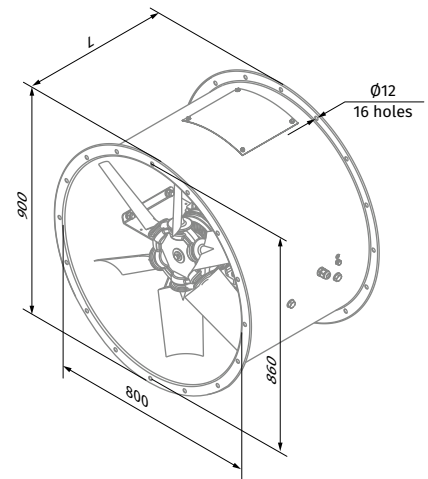
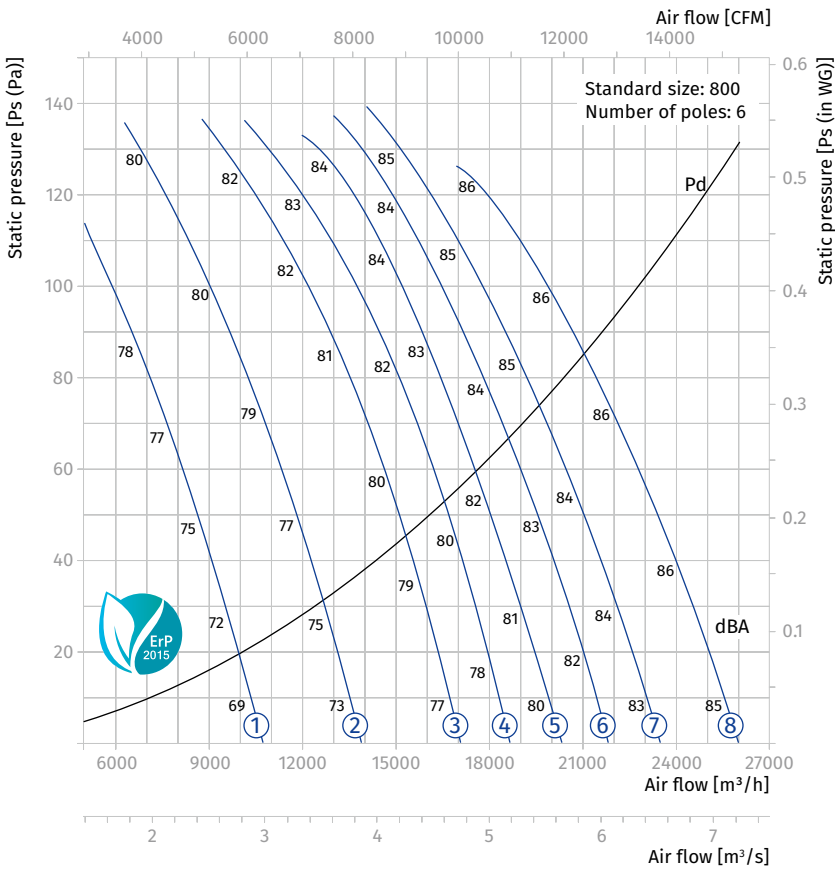

Axis-P 800-6

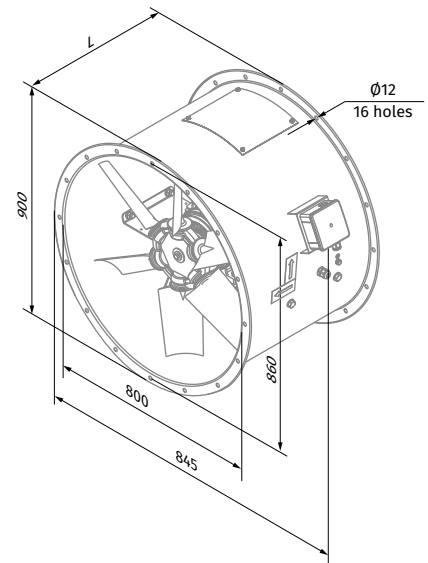

Axis-P 800-6...-K

AXIAL SMOKE EXTRACTION FANS

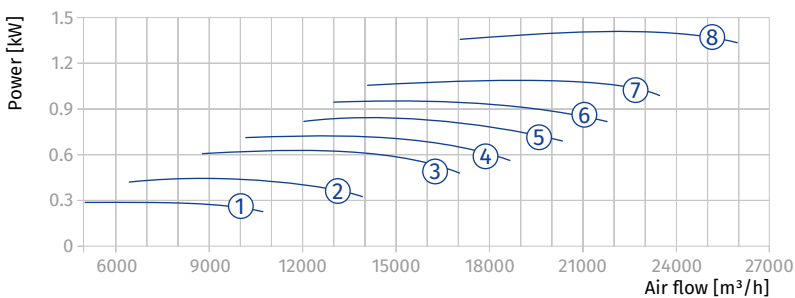

Technical data

AXIS-P 800-4

Size	Number of poles	Voltage [V/50 Hz]	Fan model with aluminum impeller (AL)	Fan model with fiberglass reinforced polyamide impeller (PAG)	Installed motor power N_y [kW]	RPM [min ⁻¹]	Number of blades	Blade setting angle [°]	Weight [kg]	Length L [mm]	Curve number on graph
800	4	3~400	Axis-P 800-4D/1.1-6/20/AL	Axis-P 800-4D/1.1-6/20/PAG	1.1	1440	6	20	115.6	450	①
			Axis-P 800-4D/1.5-6/25/AL	Axis-P 800-4D/1.5-6/25/PAG	1.5	1440	6	25	118.6	450	②
			Axis-P 800-4D/2.2-6/30/AL	Axis-P 800-4D/2.2-6/30/PAG	2.2	1440	6	30	120.7	450/(550*)	③
			Axis-P 800-4D/3-6/32.5/AL	Axis-P 800-4D/3-6/32.5/PAG	3	1440	6	32.5	129.6	550	④
			Axis-P 800-4D/3-6/35/AL	Axis-P 800-4D/3-6/35/PAG	3	1440	6	35	129.6	550	⑤
			Axis-P 800-4D/4-6/37.5/AL	Axis-P 800-4D/4-6/37.5/PAG	4	1440	6	37.5	140.7	550	⑥
			Axis-P 800-4D/4-6/40/AL	Axis-P 800-4D/4-6/40/PAG	4	1440	6	40	140.7	550	⑦
			Axis-P 800-4D/5.5-6/45/AL	Axis-P 800-4D/5.5-6/45/PAG	5.5	1440	6	45	157.6	550	⑧

* Including a motor with energy efficiency IE3

Aerodynamic characteristics

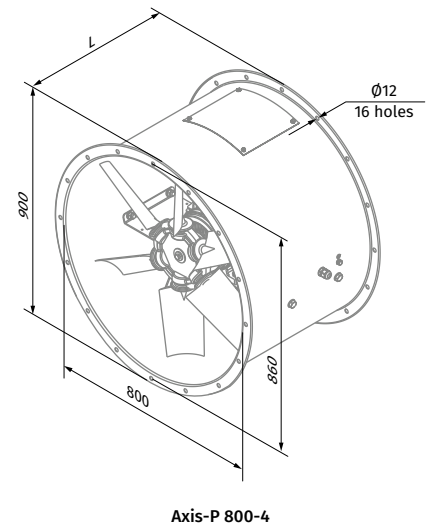
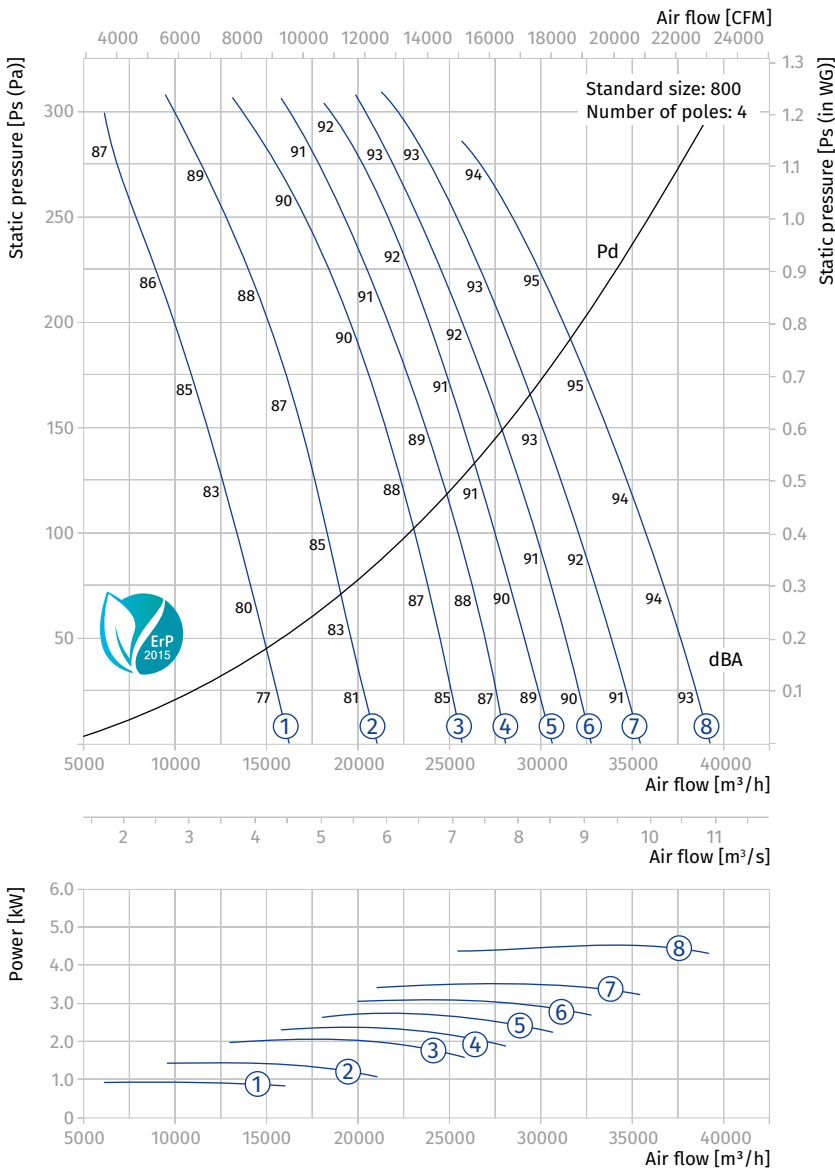

Axis-P 800-4

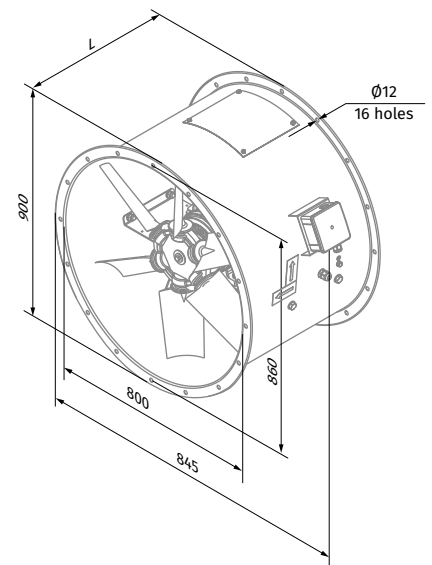

Axis-P 800-4...-K

Technical data

AXIS-P 900-6

Size	Number of poles	Voltage [V/50 Hz]	Fan model with aluminum impeller (AL)	Fan model with fiberglass reinforced polyamide impeller (PAG)	Installed motor power Ny [kW]	RPM [min ⁻¹]	Number of blades	Blade setting angle [°]	Weight [kg]	Length L [mm]	Curve number on graph
900	6	3~400	Axis-P 900-6D/0.75-8/20/AL	Axis-P 900-6D/0.75-8/20/PAG	0.75	960	8	20	121.6	450	①
			Axis-P 900-6D/1.1-8/25/AL	Axis-P 900-6D/1.1-8/25/PAG	1.1	960	8	25	121.7	450	②
			Axis-P 900-6D/1.5-8/30/AL	Axis-P 900-6D/1.5-8/30/PAG	1.5	960	8	30	129.8	550	③
			Axis-P 900-6D/1.5-8/32.5/AL	Axis-P 900-6D/1.5-8/32.5/PAG	1.5	960	8	32.5	129.8	550	④
			Axis-P 900-6D/2.2-8/35/AL	Axis-P 900-6D/2.2-8/35/PAG	2.2	960	8	35	135.3	550	⑤
			Axis-P 900-6D/2.2-8/37.5/AL	Axis-P 900-6D/2.2-8/37.5/PAG	2.2	960	8	37.5	135.3	550	⑥
			Axis-P 900-6D/2.2-8/40/AL	Axis-P 900-6D/2.2-8/40/PAG	2.2	960	8 <td 40	135.3	550	⑦	
			Axis-P 900-6D/3-8/45/AL	Axis-P 900-6D/3-8/45/PAG	3	960	8	45	155.8	650	⑧

Aerodynamic characteristics

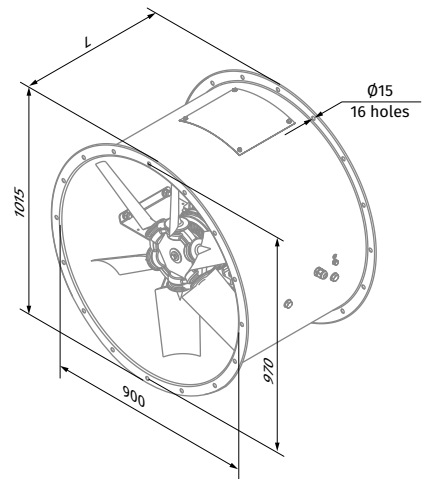
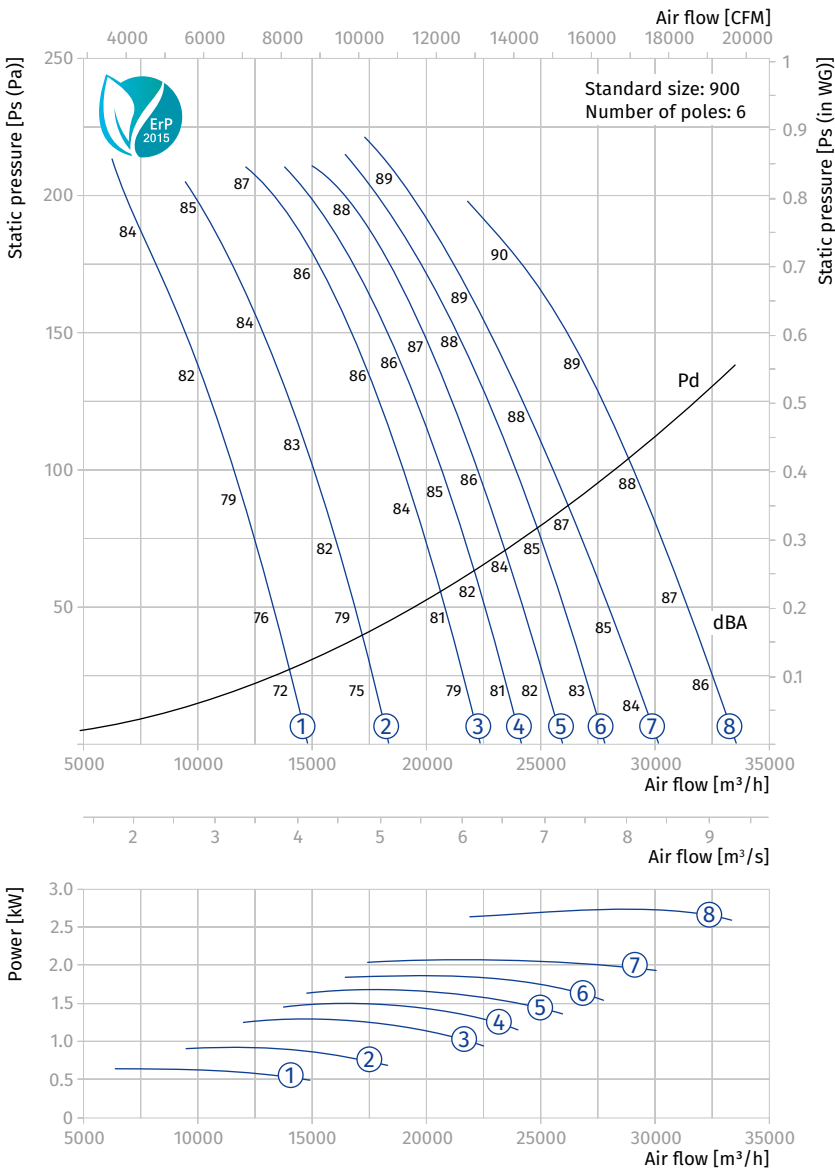

Axis-P 900-6

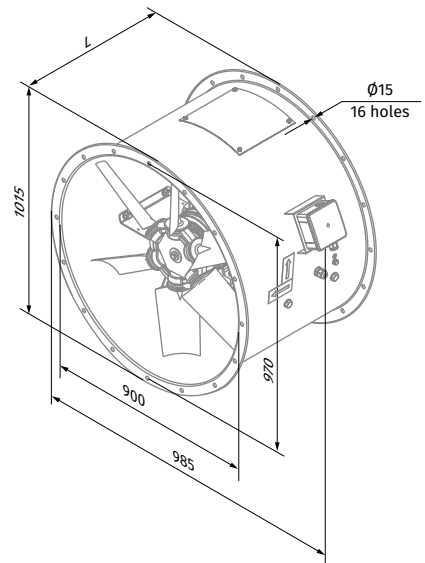

Axis-P 900-6...-K

Technical data

AXIS-P 900-4

Size	Number of poles	Voltage [V/50 Hz]	Fan model with aluminum impeller (AL)	Fan model with fiberglass reinforced polyamide impeller (PAG)	Installed motor power Ny [kW]	RPM [min ⁻¹]	Number of blades	Blade setting angle [°]	Weight [kg]	Length L [mm]	Curve number on graph
900	4	3~400	Axis-P 900-4D/3-8/20/AL	Axis-P 900-4D/3-8/20/PAG	3	1440	8	20	134.8	550	①
			Axis-P 900-4D/4-8/25/AL	Axis-P 900-4D/4-8/25/PAG	4	1440	8	25	145.9	550	②
			Axis-P 900-4D/5.5-8/30/AL	Axis-P 900-4D/5.5-8/30/PAG	5.5	1440	8	30	162.8	550	③
			Axis-P 900-4D/5.5-8/32.5/AL	Axis-P 900-4D/5.5-8/32.5/PAG	5.5	1440	8	32.5	162.8	550	④
			Axis-P 900-4D/7.5-8/35/AL	Axis-P 900-4D/7.5-8/35/PAG	7.5	1440	8	35	165.3	650	⑤
			Axis-P 900-4D/7.5-8/37.5/AL	Axis-P 900-4D/7.5-8/37.5/PAG	7.5	1440	8	37.5	165.3	650	⑥
			Axis-P 900-4D/7.5-8/40/AL	Axis-P 900-4D/7.5-8/40/PAG	7.5	1440	8	40	165.3	650	⑦
			Axis-P 900-4D/11-8/45/AL	Axis-P 900-4D/11-8/45/PAG	11	1440	8	45	199.6	750	⑧

Aerodynamic characteristics

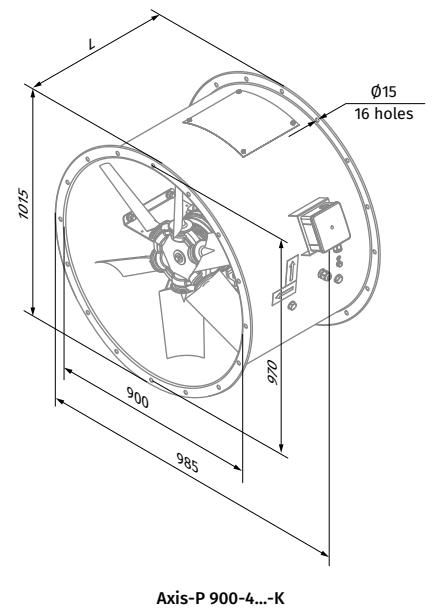
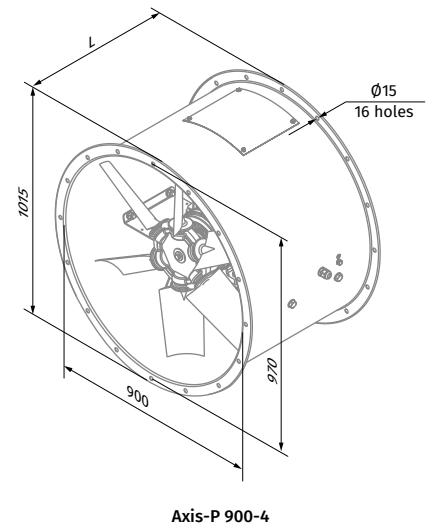
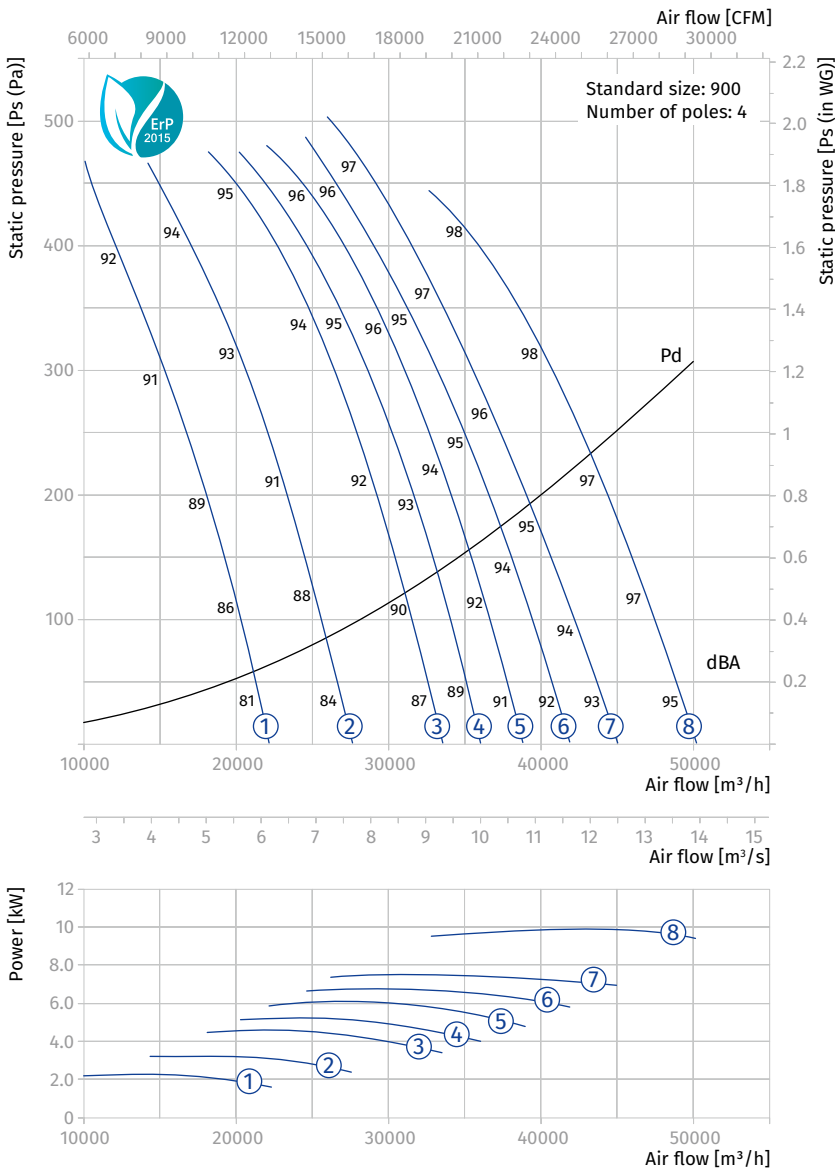

AXIAL SMOKE EXTRACTION FANS

Technical data

AXIS-P 1000-6

Size	Number of poles	Voltage [V/50 Hz]	Fan model with aluminum impeller (AL)	Fan model with fiberglass reinforced polyamide impeller (PAG)	Installed motor power Ny [kW]	RPM [min ⁻¹]	Number of blades	Blade setting angle [°]	Weight [kg]	Length L [mm]	Curve number on graph
1000	6	3~400	Axis-P 1000-6D/1.5-8/25/AL	Axis-P 1000-6D/1.5-8/25/PAG	1.5	960	8	25	167.5	550	①
			Axis-P 1000-6D/2.2-8/30/AL	Axis-P 1000-6D/2.2-8/30/PAG	2.2	960	8	30	173	550	②
			Axis-P 1000-6D/2.2-8/32.5/AL	Axis-P 1000-6D/2.2-8/32.5/PAG	2.2	960	8	32.5	173	550	③
			Axis-P 1000-6D/3-8/35/AL	Axis-P 1000-6D/3-8/35/PAG	3	960	8	35	193.5	650	④
			Axis-P 1000-6D/3-8/37.5/AL	Axis-P 1000-6D/3-8/37.5/PAG	3	960	8	37.5	193.5	650	⑤
			Axis-P 1000-6D/4-8/40/AL	Axis-P 1000-6D/4-8/40/PAG	4	960	8	40	203.5	650	⑥
			Axis-P 1000-6D/5.5-8/45/AL	Axis-P 1000-6D/5.5-8/45/PAG	5.5	960	8	45	207.5	650	⑦
			Axis-P 1000-6D/5.5-8/50/AL	Axis-P 1000-6D/5.5-8/50/PAG	5.5	960	8	50	207.5	650	⑧

Aerodynamic characteristics

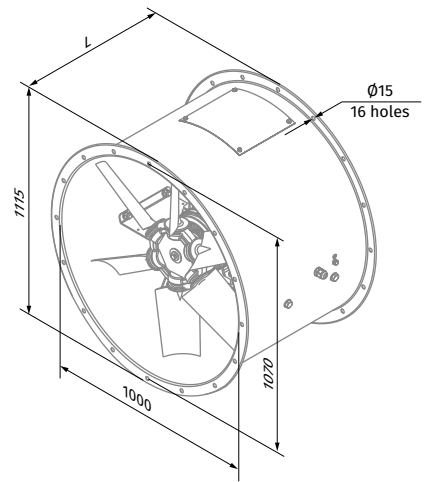
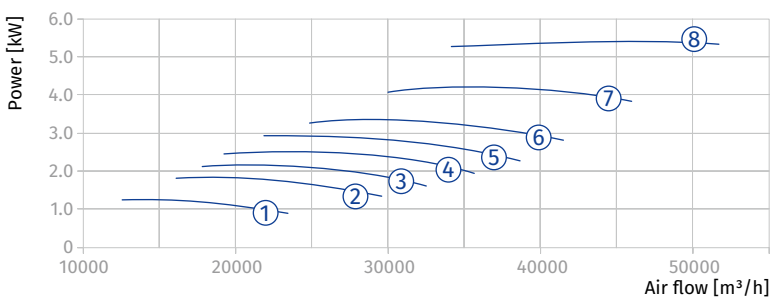
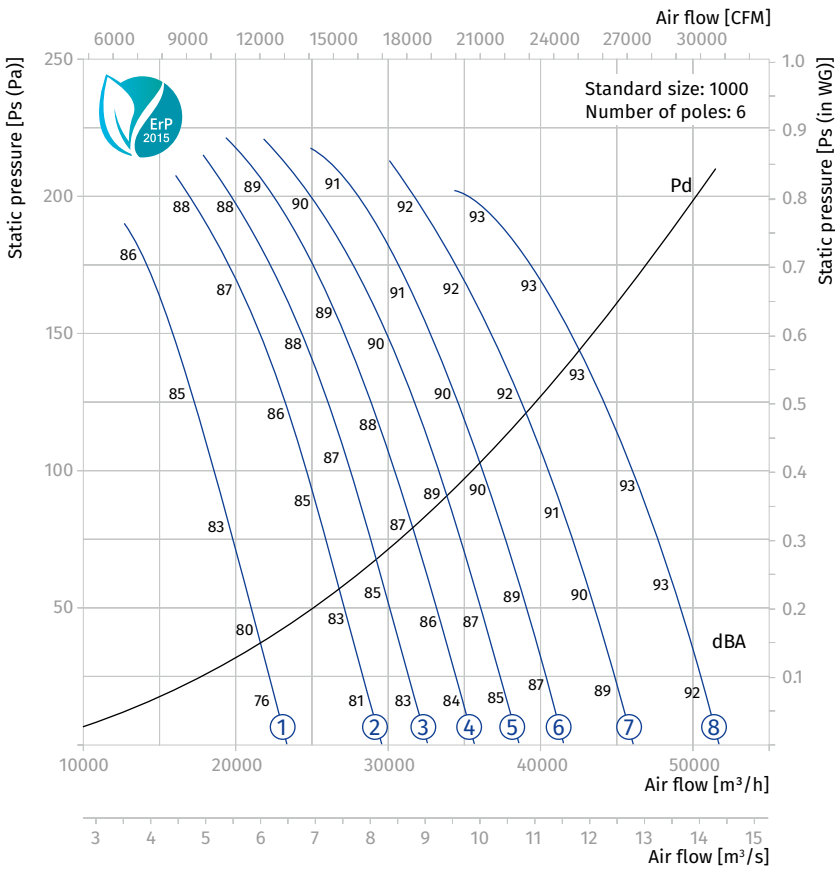

Axis-P 1000-6

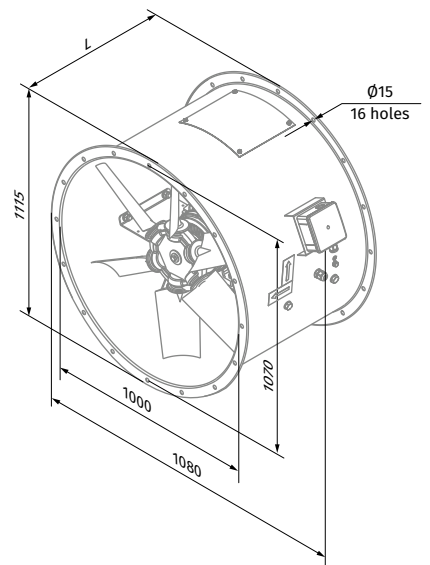

Axis-P 1000-6...-K

Technical data

AXIS-P 1000-4

Size	Number of poles	Voltage [V/50 Hz]	Fan model with aluminum impeller (AL)	Fan model with fiberglass reinforced polyamide impeller (PAG)	Installed motor power N_y [kW]	RPM [min ⁻¹]	Number of blades	Blade setting angle [°]	Weight [kg]	Length L [mm]	Curve number on graph
1000	4	3~400	Axis-P 1000-4D/5.5-8/25/AL	Axis-P 1000-4D/5.5-8/25/PAG	5.5	1440	8	25	200.5	550	①
			Axis-P 1000-4D/7.5-8/30/AL	Axis-P 1000-4D/7.5-8/30/PAG	7.5	1440	8	30	203	650	②
			Axis-P 1000-4D/7.5-8/32.5/AL	Axis-P 1000-4D/7.5-8/32.5/PAG	7.5	1440	8	32.5	203	650	③
			Axis-P 1000-4D/9.2-8/35/AL	Axis-P 1000-4D/9.2-8/35/PAG	9.2	1440	8	35	233.5	650	④
			Axis-P 1000-4D/11-8/37.5/AL	Axis-P 1000-4D/11-8/37.5/PAG	11	1440	8	37.5	237.3	800	⑤
			Axis-P 1000-4D/11-8/40/AL	Axis-P 1000-4D/11-8/40/PAG	11	1440	8	40	237.3	800	⑥
			Axis-P 1000-4D/15-8/45/AL	Axis-P 1000-4D/15-8/45/PAG	15	1440	8	45	256.4	800	⑦
			Axis-P 1000-4D/18.5-8/50/AL	Axis-P 1000-4D/18.5-8/50/PAG	18.5	1440	8	50	301.9	900	⑧

Aerodynamic characteristics

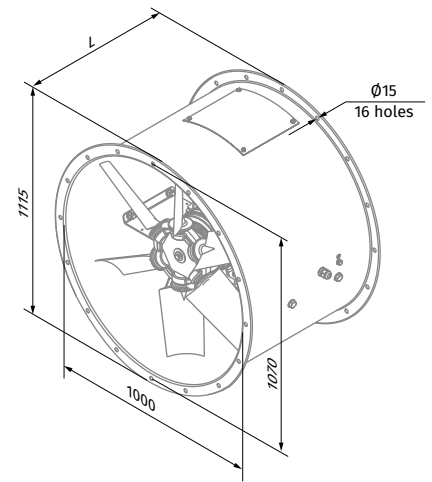
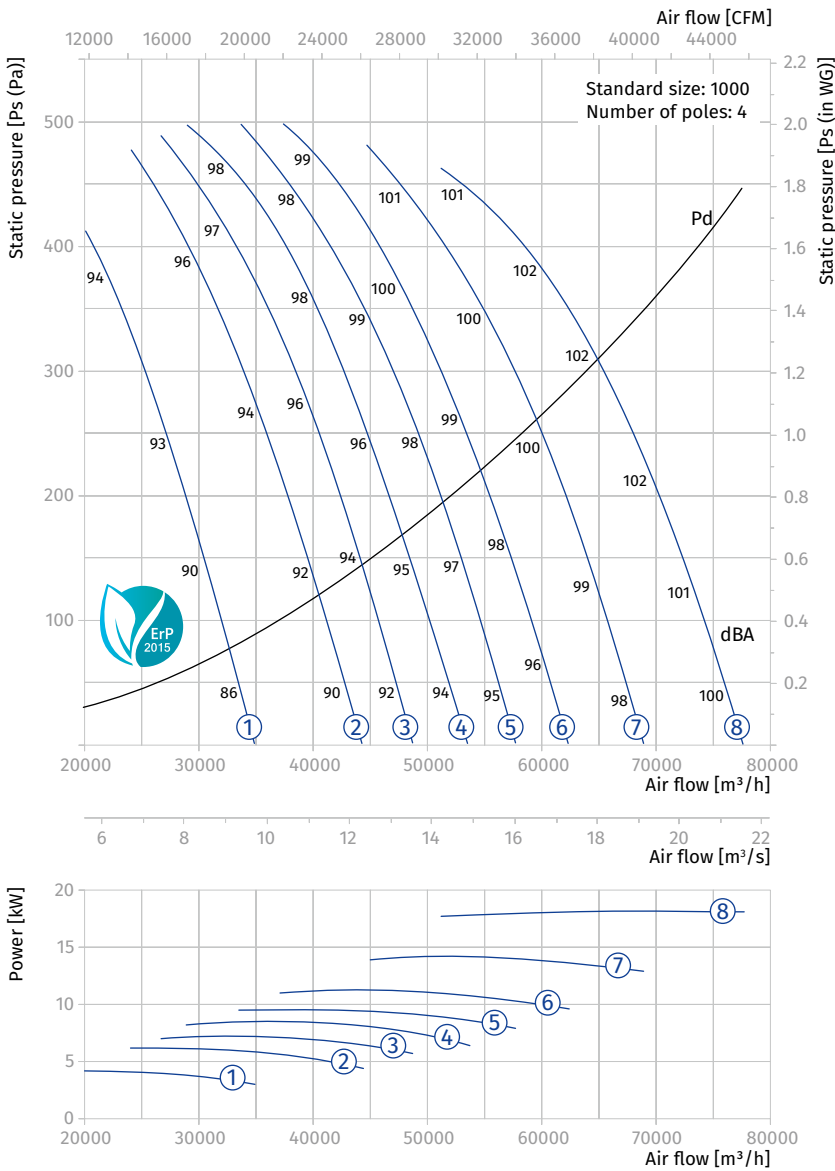

Axis-P 1000-4

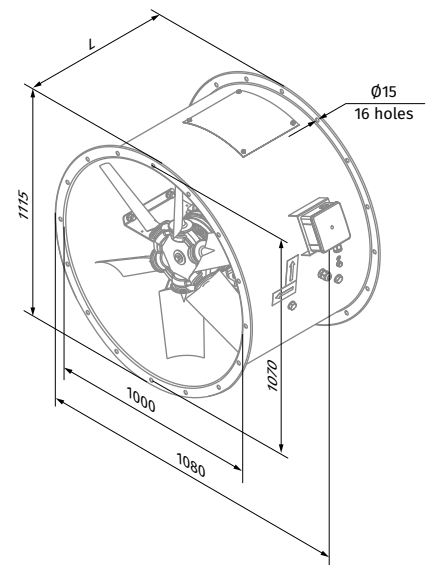

Axis-P 1000-4...-K

AXIAL SMOKE EXTRACTION FANS

Technical data

AXIS-P 1120-6

Size	Number of poles	Voltage [V/50 Hz]	Fan model with aluminum impeller (AL)	Fan model with fiberglass reinforced polyamide impeller (PAG)	Installed motor power Ny [kW]	RPM [min ⁻¹]	Number of blades	Blade setting angle [°]	Weight [kg]	Length L [mm]	Curve number on graph
1120	6	3~400	Axis-P 1120-6D/2.2-8/25/AL	Axis-P 1120-6D/2.2-8/25/PAG	2.2	960	8	25	192	550	①
			Axis-P 1120-6D/3-8/30/AL	Axis-P 1120-6D/3-8/30/PAG	3	960	8	30	212.5	650	②
			Axis-P 1120-6D/4-8/32.5/AL	Axis-P 1120-6D/4-8/32.5/PAG	4	960	8	32.5	222.5	650	③
			Axis-P 1120-6D/4-8/35/AL	Axis-P 1120-6D/4-8/35/PAG	4	960	8	35	222.5	650	④
			Axis-P 1120-6D/5.5-8/37.5/AL	Axis-P 1120-6D/5.5-8/37.5/PAG	5.5	960	8	37.5	226.5	650	⑤
			Axis-P 1120-6D/5.5-8/40/AL	Axis-P 1120-6D/5.5-8/40/PAG	5.5	960	8	40	226.5	650	⑥
			Axis-P 1120-6D/7.5-8/45/AL	Axis-P 1120-6D/7.5-8/45/PAG	7.5	960	8	45	254.8	800	⑦
			Axis-P 1120-6D/9.2-8/50/AL	Axis-P 1120-6D/9.2-8/50/PAG	9.2	960	8	50	272.5	800	⑧

Aerodynamic characteristics

AXIAL SMOKE EXTRACTION FANS

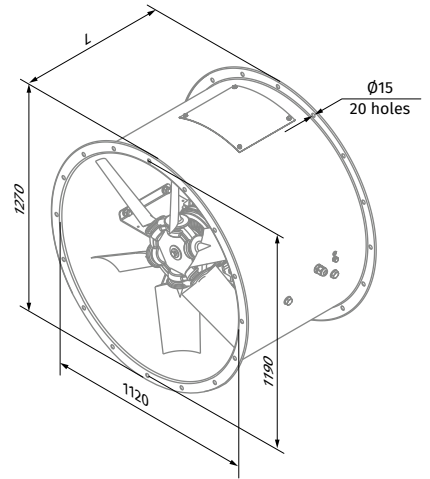
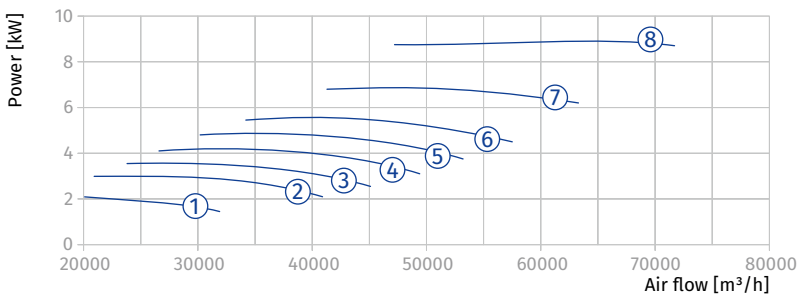
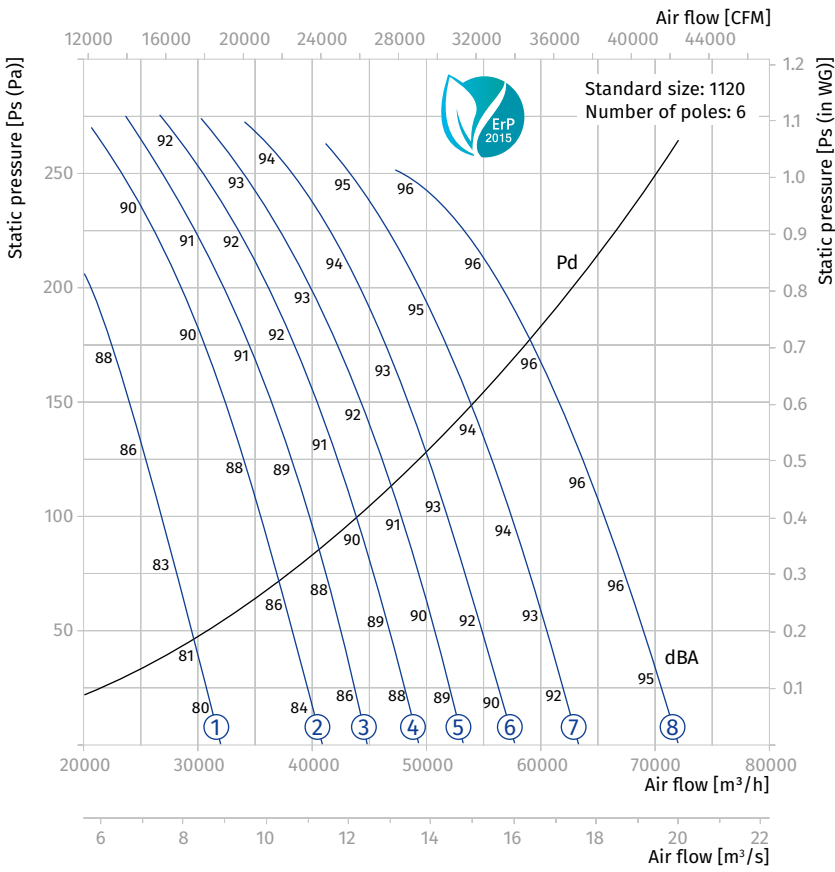

Axis-P 1120-6

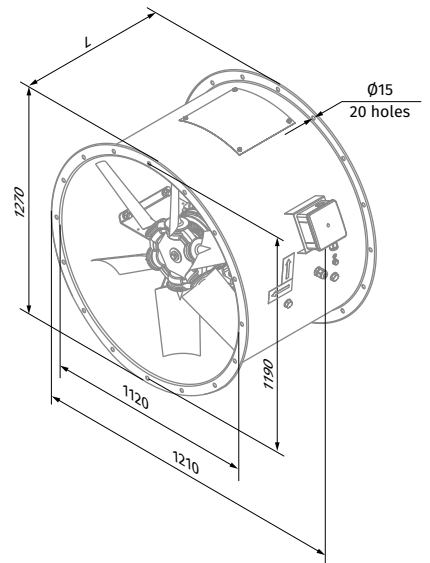

Axis-P 1120-6...-K

Technical data

AXIS-P 1120-4

Size	Number of poles	Voltage [V/50 Hz]	Fan model with aluminum impeller (AL)	Fan model with fiberglass reinforced polyamide impeller (PAG)	Installed motor power N_y [kW]	RPM [min ⁻¹]	Number of blades	Blade setting angle [°]	Weight [kg]	Length L [mm]	Curve number on graph
1120	4	3~400	Axis-P 1120-4D/7.5-8/25/AL	Axis-P 1120-4D/7.5-8/25/PAG	7.5	1440	8	25	222	650	①
			Axis-P 1120-4D/11-8/30/AL	Axis-P 1120-4D/11-8/30/PAG	11	1440	8	30	256.3	800	②
			Axis-P 1120-4D/11-8/32.5/AL	Axis-P 1120-4D/11-8/32.5/PAG	11	1440	8	32.5	256.3	800	③
			Axis-P 1120-4D/15-8/35/AL	Axis-P 1120-4D/15-8/35/PAG	15	1440	8	35	275.4	800	④
			Axis-P 1120-4D/18.5-8/37.5/AL	Axis-P 1120-4D/18.5-8/37.5/PAG	18.5	1440	8	37.5	320.9	900	⑤
			Axis-P 1120-4D/18.5-8/40/AL	Axis-P 1120-4D/18.5-8/40/PAG	18.5	1440	8	40	320.9	900	⑥
			Axis-P 1120-4D/22-8/45/AL	Axis-P 1120-4D/22-8/45/PAG	22	1440	8	45	334.2	900	⑦

Aerodynamic characteristics

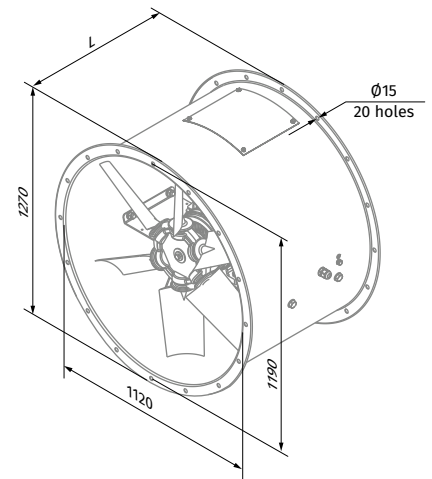
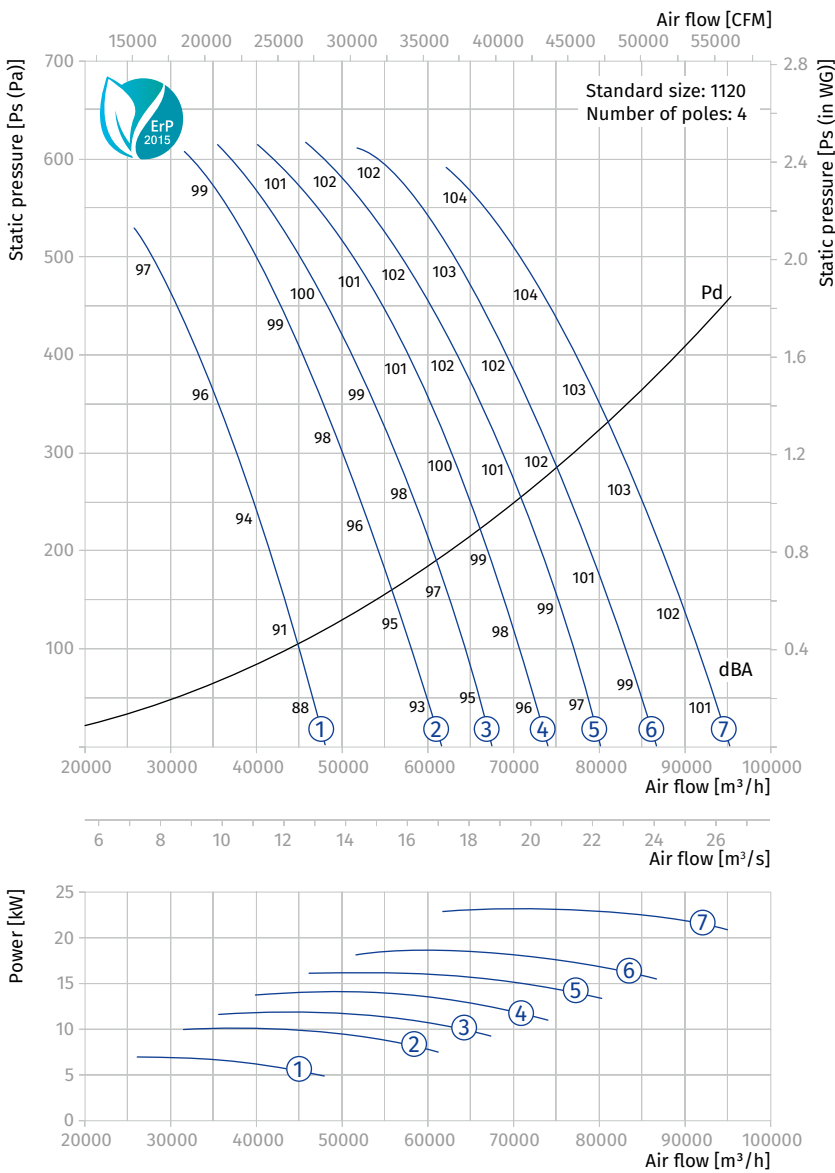

Axis-P 1120-4

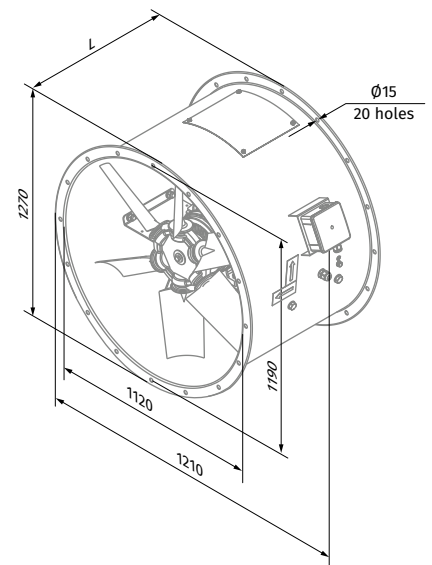

Axis-P 1120-4...-K

Technical data

AXIS-P 1250-6

Size	Number of poles	Voltage [V/50 Hz]	Fan model with aluminum impeller (AL)	Fan model with fiberglass reinforced polyamide impeller (PAG)	Installed motor power Ny [kW]	RPM [min ⁻¹]	Number of blades	Blade setting angle [°]	Weight [kg]	Length L [mm]	Curve number on graph
1250	6	3~400	Axis-P 1250-6D/2.2-8/25/AL	Axis-P 1250-6D/2.2-8/25/PAG	2.2	960	8	25	211	550	①
			Axis-P 1250-6D/3-8/30/AL	Axis-P 1250-6D/3-8/30/PAG	3	960	8	30	231.5	650	②
			Axis-P 1250-6D/4-8/32.5/AL	Axis-P 1250-6D/4-8/32.5/PAG	4	960	8	32.5	241.5	650	③
			Axis-P 1250-6D/5.5-8/35/AL	Axis-P 1250-6D/5.5-8/35/PAG	5.5	960	8	35	245.5	650	④
			Axis-P 1250-6D/5.5-8/37.5/AL	Axis-P 1250-6D/5.5-8/37.5/PAG	5.5	960	8	37.5	245.5	650	⑤
			Axis-P 1250-6D/7.5-8/40/AL	Axis-P 1250-6D/7.5-8/40/PAG	7.5	960	8	40	273.8	800	⑥
			Axis-P 1250-6D/9.2-8/45/AL	Axis-P 1250-6D/9.2-8/45/PAG	9.2	960	8	45	291.5	800	⑦
			Axis-P 1250-6D/11-8/50/AL	Axis-P 1250-6D/11-8/50/PAG	11	960	8	50	299.3	800	⑧

Aerodynamic characteristics

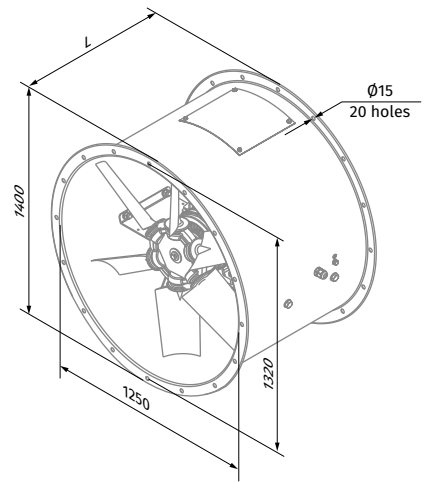
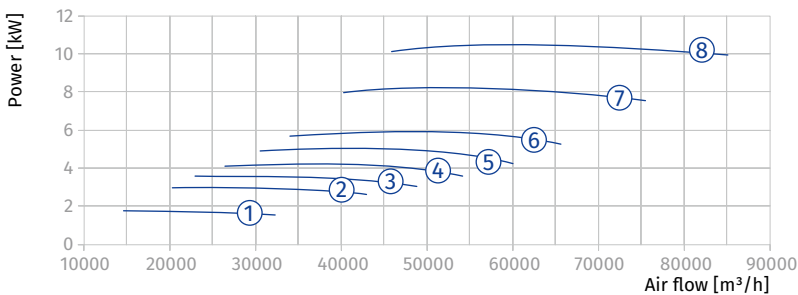
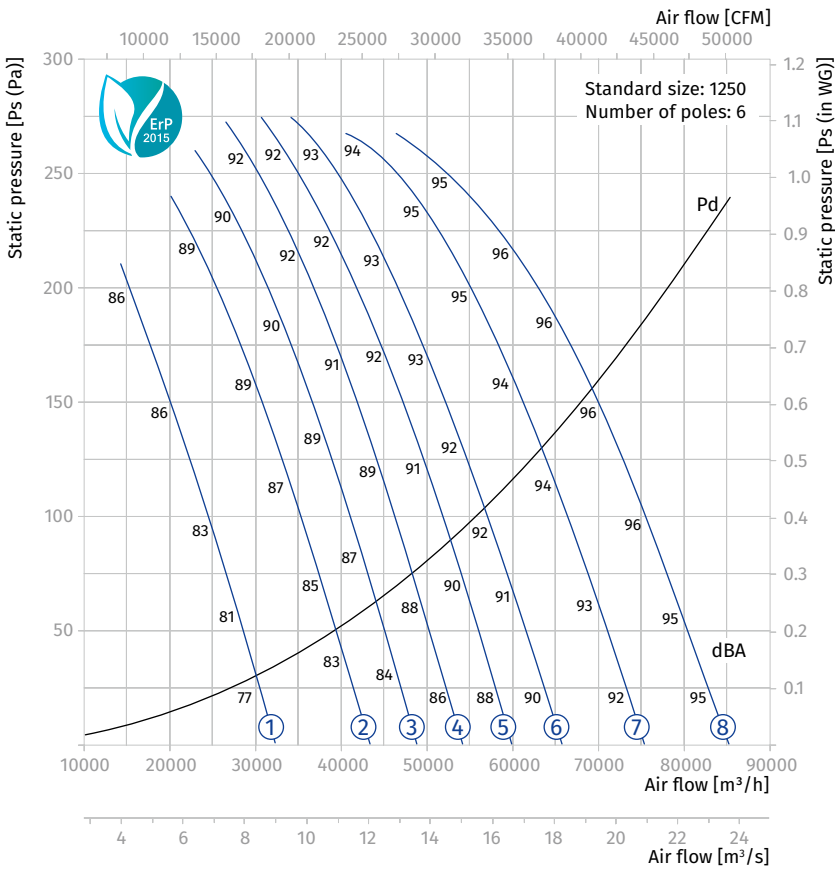

Axis-P 1250-6

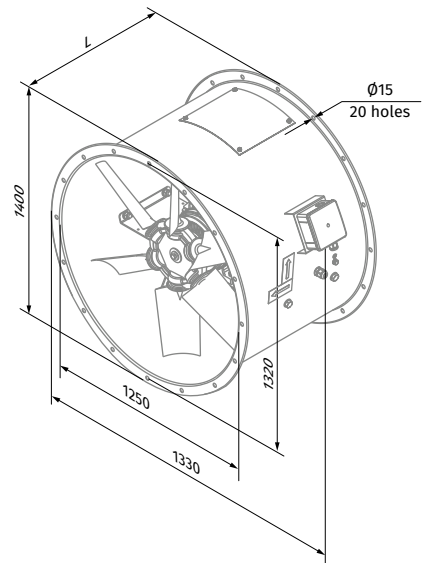

Axis-P 1250-6...-K

AXIAL SMOKE EXTRACTION FANS

Technical data

AXIS-P 1250-4

Size	Number of poles	Voltage [V/50 Hz]	Fan model with aluminum impeller (AL)	Fan model with fiberglass reinforced polyamide impeller (PAG)	Installed motor power Ny [kW]	RPM [min ⁻¹]	Number of blades	Blade setting angle [°]	Weight [kg]	Length L [mm]	Curve number on graph
1250	4	3~400	Axis-P 1250-4D/7.5-8/25/AL	Axis-P 1250-4D/7.5-8/25/PAG	7.5	1440	8	25	241	650	①
			Axis-P 1250-4D/11-8/30/AL	Axis-P 1250-4D/11-8/30/PAG	11	1440	8	30	275.3	800	②
			Axis-P 1250-4D/15-8/32.5/AL	Axis-P 1250-4D/15-8/32.5/PAG	15	1440	8	32.5	294.4	800	③
			Axis-P 1250-4D/15-8/35/AL	Axis-P 1250-4D/15-8/35/PAG	15	1440	8	35	294.4	800	④
			Axis-P 1250-4D/18.5-8/37.5/AL	Axis-P 1250-4D/18.5-8/37.5/PAG	18.5	1440	8	37.5	339.9	900	⑤
			Axis-P 1250-4D/22-8/40/AL	Axis-P 1250-4D/22-8/40/PAG	22	1440	8	40	353.2	900	⑥
			Axis-P 1250-4D/30-8/45/AL	Axis-P 1250-4D/30-8/45/PAG	30	1440	8	45	416.2	900	⑦

Aerodynamic characteristics

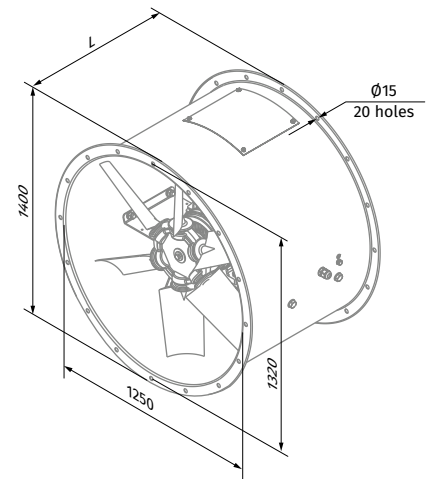
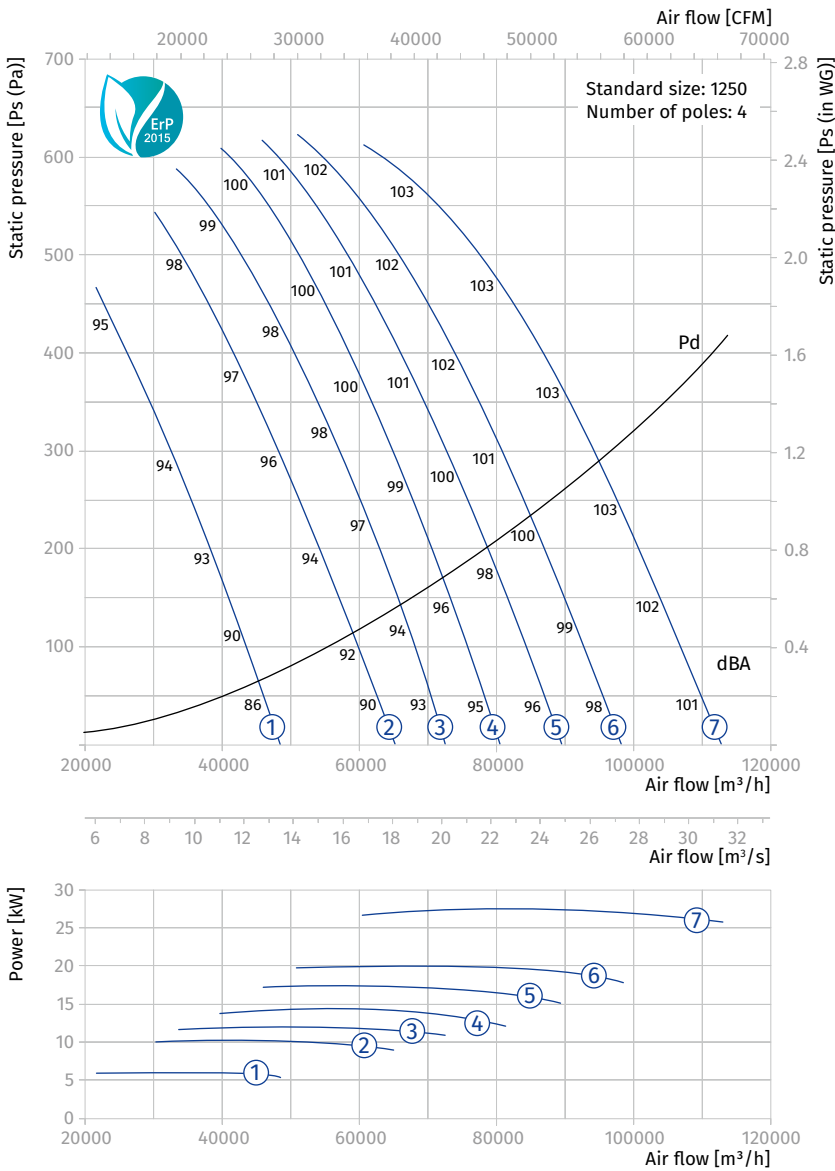

Axis-P 1250-4

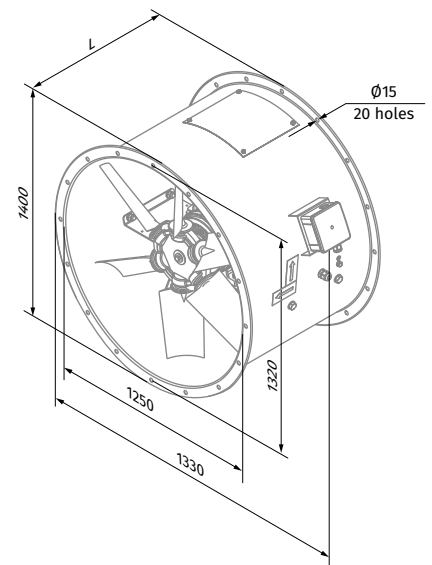

Axis-P 1250-4...-K

AXIAL SMOKE EXTRACTION FANS

AXIS-FP

Axial smoke extraction fans

Use

- The fans are used for extraction of smoke in case of fire and removal of hot air outside. The fans are also used for general ventilation systems.
- The fans are rated for permanent operation at ambient air temperatures from -60 °C up to +50 °C (depends on climatic category, see the Designation key). The fans are able to operate 2 hours at the temperatures +300 °C and +400 °C.
- The fans with a fire resistance class of 200 °C/2 hours can be produced on request. The characteristics of the 200 °C/2 hours fans are completely identical to 300 °C/2 hours fans.



Air flow:
up to 114 000 m³/h



Fire resistance rating:
300 °C/2 hours
400 °C/2 hours

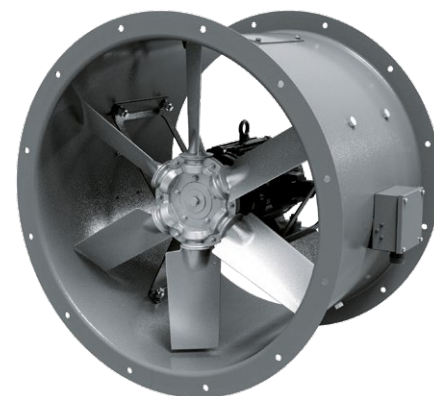

Design

- The fan consists of a casing, an impeller and a motor. The metal casing with rolled flanges helps achieve outstanding rigidity and minimum clearances between the casing and the blades. There is an inspection hatch in the casing for easy maintenance.
- All the casing components are powder coated for improved protection against the environmental effects.
- The weight of the fans may differ from the one stated in the catalogue and depends on the components used (motor, terminal box, etc.).

Motor

- The fans are equipped with three-phase (400 V/50 Hz) motors. Motor ingress protection rating is IP55. Depending on the model, the fans have single- or double-speed modifications.
- The single-speed models are equipped with 2-, 4- or 6-pole motors.
- The double-speed models are equipped with 2/4-, 4/6- or 4/8-pole motors.

Impeller

- Depending on the size and the required air capacity the fans are equipped with impellers with 4, 5, 6, 7, 8, 9 or 12 blades angled from 20° to 50° to ensure precise matching of fans with the operating point.
- The specially designed impeller blades ensure high efficiency of the fan while keeping noise well under control.
- The impellers are dynamically balanced. Low weight and low moment of the impeller inertia help reduce the fan start-up time.
- The fan blades are made of cast aluminium.

Mounting

- The fans can be mounted on any flat surface or directly into a ventilation duct. The units are suitable for both horizontal and vertical configurations.
- Installation in the air duct requires flanges to attach the fan to the ductwork.
- To attach the fan to the floor, the wall or the ceiling use the O-AF carriers (not included as standard, should be purchased separately).
- The fans are suitable for installation on rooftops.

Designation key

Casing
Motor
Impeller
Modification
AXIS-FP 630 K - 2 D / 5.5 - 8 / 35 / AL - U 1 - 300/2

Axis-FP:
Axial smoke extraction fan

Standard size (duct diameter) [mm]

Modification:
 _: standard casing
 K: shortened casing

Number of motor poles

Motor phase:
 E: single-phase
 D: three-phase

Motor power [kW]

Number of impeller blades [items]

Blade setting angle [°]

Blade material:
 AL: aluminium

Climatic category:
 U: moderate climate (-40 ... +40 °C)
 HL: cold climate (-60 ... +40 °C)
 UHL: moderate and cold climate (-60 ... +40 °C)
 T: tropical climate (-10 ... +50 °C)
 M: maritime moderately cold climate (-40 ... +40 °C)
 O: general climatic modification (except maritime climate) (-60 ... +50 °C)
 OM: general maritime climatic modification (-40 ... +40 °C)
 V: universal climatic modification (-60 ... +50 °C)

Placement category:
 1: outdoors
 2: under a shed or indoors with the same conditions as outdoors except solar radiation and precipitation
 3: in closed rooms without artificial climate control
 4: in closed rooms with artificial climate control (ventilation, heating)
 5: in rooms with high levels of humidity, without artificial climate control

Fire resistance rating:
 300/2: 300 °C, 2 hours
 400/2: 400 °C, 2 hours

Overall dimensions [mm]

Model	Ø D	Ø D1	Ø D2	Ø d	n	W
Axis-FP 400...	400	450	490	8	12	525
Axis-FP 450...	450	500	540	8	12	580
Axis-FP 500...	500	560	600	12	12	620
Axis-FP 560...	560	620	660	12	12	680
Axis-FP 630...	630	690	730	12	12	750
Axis-FP 700...	710	770	810	12	16	845
Axis-FP 800...	800	860	900	12	16	925
Axis-FP 900...	900	970	1015	15	16	1025
Axis-FP 1000...	1000	1070	1115	15	16	1140
Axis-FP 1120...	1120	1190	1270	15	20	1280
Axis-FP 1250...	1250	1320	1400	15	20	1450

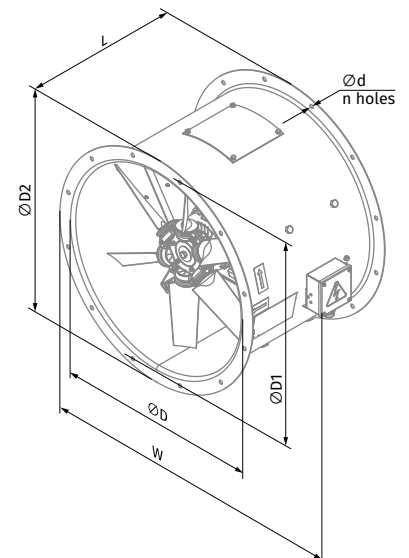

Technical data AXIS-FP...300/2

AXIS-FP 400...300/2

Size	Number of poles	Voltage [V/50 Hz]	Fan model	Installed motor power Ny [kW]	RPM [min ⁻¹]	Number of blades	Blade setting angle [°]	Weight [kg]	Length L [mm]	Curve number on graph
Axis-FP 400-2D...300/2										
400	2	3~400	Axis-FP 400-2D/0.55-6/25/AL	0.55	2880	6	25	23	400	①
			Axis-FP 400-2D/0.75-6/30/AL	0.75	2880	6	30	24.6	400	②
			Axis-FP 400-2D/1.1-6/35/AL	1.1	2880	6	35	28.6	400	③
			Axis-FP 400-2D/1.5-6/40/AL	1.5	2880	6	40	30.1	400	④
			Axis-FP 400-2D/1.5-6/45/AL	1.5	2880	6	45	30.1	400	⑤
			Axis-FP 400-2D/2.2-8/45/AL	2.2	2880	8	45	32.6	400	⑥
Axis-FP 400-4D...300/2										
400	4	3~400	Axis-FP 400-4D/0.55-6/30/AL	0.55	1440	6	30	24.5	400	①
			Axis-FP 400-4D/0.55-6/35/AL	0.55	1440	6	35	24.5	400	②
			Axis-FP 400-4D/0.55-6/40/AL	0.55	1440	6	40	24.5	400	③
			Axis-FP 400-4D/0.55-6/45/AL	0.55	1440	6	45	24.5	400	④
			Axis-FP 400-4D/0.55-8/45/AL	0.55	1440	8	45	25.0	400	⑤

Standard size: 400
Number of poles: 2
Fire resistance rating: 300/2

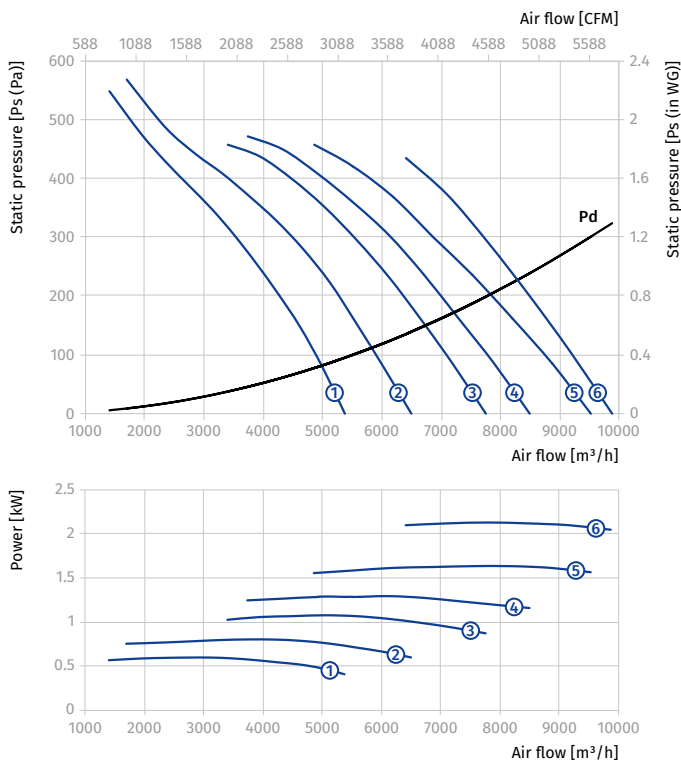

Standard size: 400
Number of poles: 4
Fire resistance rating: 300/2

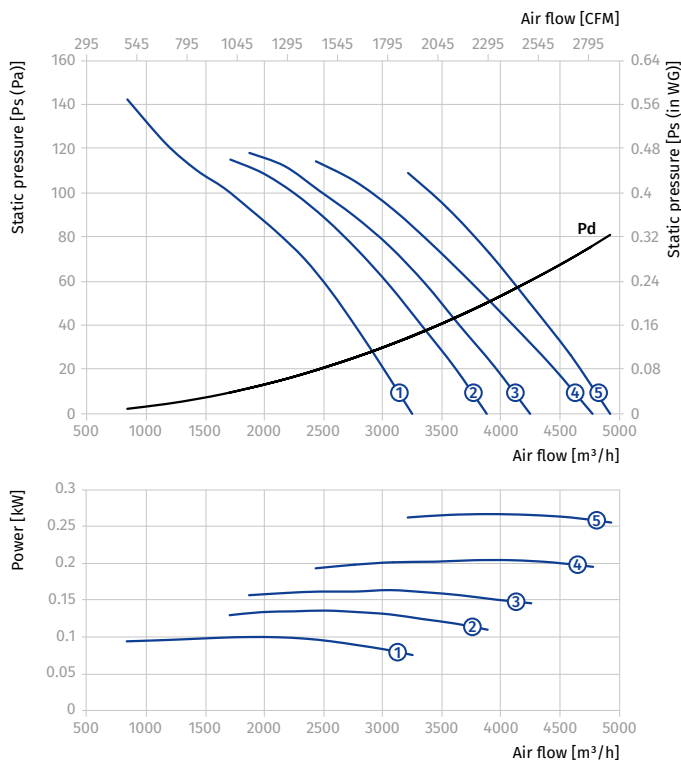

AXIS-FP 400...300/2

Size	Number of poles	Voltage [V/50 Hz]	Fan model	Installed motor power N_y [kW]	RPM [min^{-1}]	Number of blades	Blade setting angle [°]	Weight [kg]	Length L [mm]	Curve number on graph
Axis-FP 400-2/4D...300/2										
400	2/4	3~400	Axis-FP 400-2/4D/0.8/0.2-6/30/AL	0.8/0.2	2880/1440	6	30	29.1	400	①
			Axis-FP 400-2/4D/1.1/0.25-6/35/AL	1.1/0.25	2880/1440	6	35	30.1	400	②
			Axis-FP 400-2/4D/1.5/0.37-6/40/AL	1.5/0.37	2880/1440	6	40	35.8	400	③
			Axis-FP 400-2/4D/1.5/0.37-6/45/AL	1.5/0.37	2880/1440	6	45	35.8	400	④
			Axis-FP 400-2/4D/2.2/0.5-8/45/AL	2.2/0.5	2880/1440	8	45	38	400	⑤

Standard size: 400
 Number of poles: 2
 Fire resistance rating: 300/2

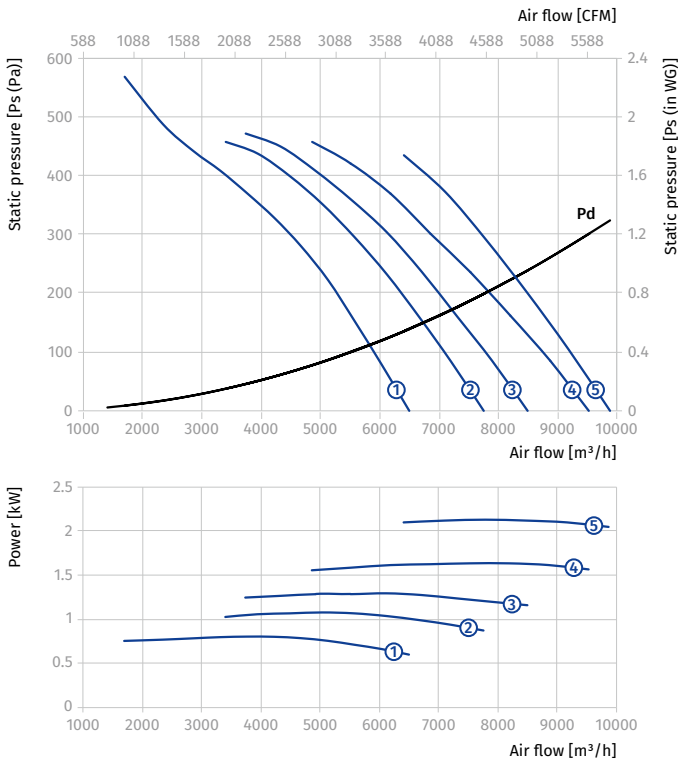

Standard size: 400
 Number of poles: 4
 Fire resistance rating: 300/2

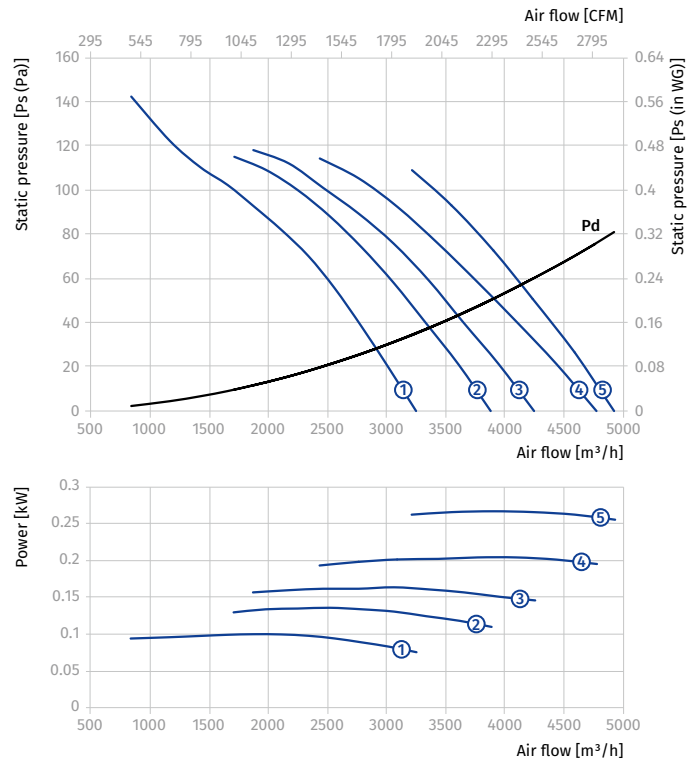

AXIS-FP 450...300/2

Size	Number of poles	Voltage [V/50 Hz]	Fan model	Installed motor power Ny [kW]	RPM [min ⁻¹]	Number of blades	Blade setting angle [°]	Weight [kg]	Length L [mm]	Curve number on graph
Axis-FP 450-2D...300/2										
450	2	3~400	Axis-FP 450-2D/0.75-6/25/AL	0.75	2880	6	25	26.1	400	①
			Axis-FP 450-2D/1.1-6/30/AL	1.1	2880	6	30	30.1	400	②
			Axis-FP 450-2D/1.5-6/35/AL	1.5	2880	6	35	31.6	400	③
			Axis-FP 450-2D/2.2-6/40/AL	2.2	2880	6	40	34	400	④
			Axis-FP 450-2D/3-8/40/AL	3	2880	8	40	41	400	⑤
			Axis-FP 450-2D/4-8/45/AL	4	2880	8	45	52.8	500	⑥
Axis-FP 450-4D...300/2										
450	4	3~400	Axis-FP 450-4D/0.55-6/25/AL	0.55	1440	6	25	24.6	400	①
			Axis-FP 450-4D/0.55-6/30/AL	0.55	1440	6	30	24.6	400	②
			Axis-FP 450-4D/0.55-6/35/AL	0.55	1440	6	35	24.6	400	③
			Axis-FP 450-4D/0.55-6/40/AL	0.55	1440	6	40	24.6	400	④
			Axis-FP 450-4D/0.55-8/40/AL	0.55	1440	8	40	24.6	400	⑤
			Axis-FP 450-4D/0.55-8/45/AL	0.55	1440	8	45	25	400	⑥

Standard size: 450
Number of poles: 2
Fire resistance rating: 300/2

Standard size: 450
Number of poles: 4
Fire resistance rating: 300/2

AXIAL SMOKE EXTRACTION FANS

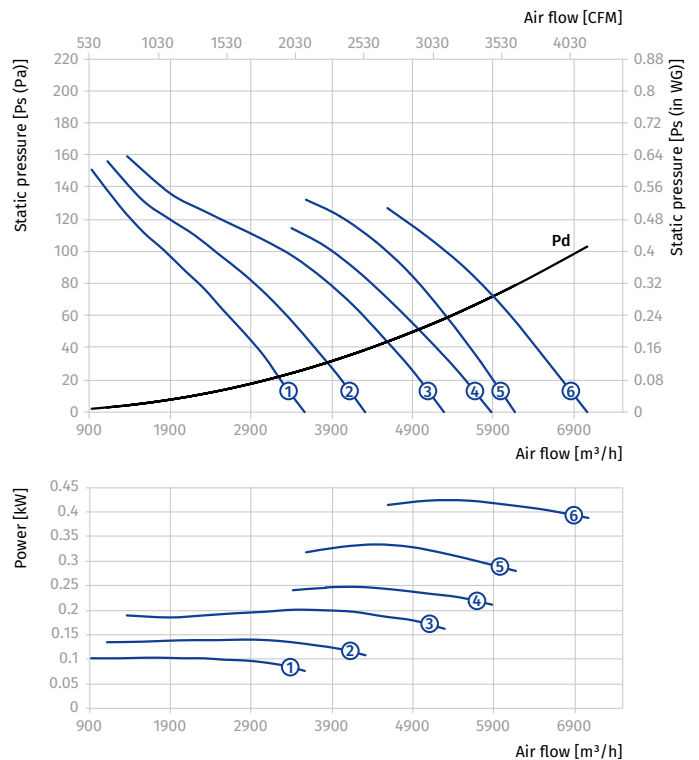
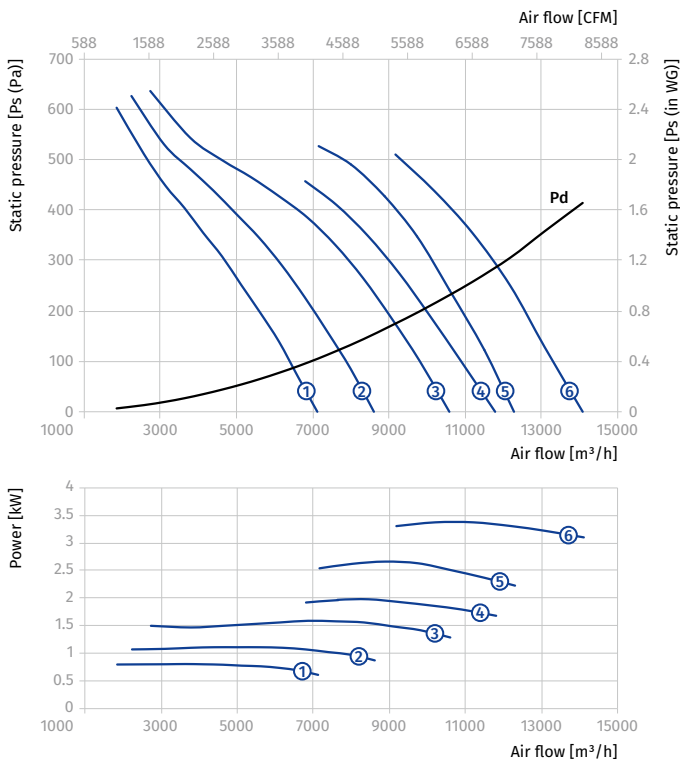

AXIS-FP 450...300/2

Size	Number of poles	Voltage [V/50 Hz]	Fan model	Installed motor power N_y [kW]	RPM [min^{-1}]	Number of blades	Blade setting angle [°]	Weight [kg]	Length L [mm]	Curve number on graph
Axis-FP 450-2/4D...300/2										
450	2/4	3~400	Axis-FP 450-2/4D/0.8/0.2-6/25/AL	0.8/0.2	2880/1440	6	25	30.6	400	①
			Axis-FP 450-2/4D/1.1/0.25-6/30/AL	1.1/0.25	2880/1440	6	30	31.6	400	②
			Axis-FP 450-2/4D/1.5/0.37-6/35/AL	1.5/0.37	2880/1440	6	35	37.3	400	③
			Axis-FP 450-2/4D/2.2/0.5-6/40/AL	2.2/0.5	2880/1440	6	40	39.3	400	④
			Axis-FP 450-2/4D/3.1/0.8-8/40/AL	3.1/0.8	2880/1440	8	40	51.9	500	⑤
			Axis-FP 450-2/4D/4.4/1.1-8/45/AL	4.4/1.1	2880/1440	8	45	63.8	500	⑥

Standard size: 450
 Number of poles: 2
 Fire resistance rating: 300/2

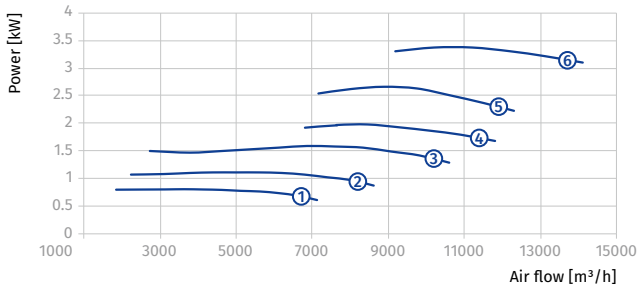
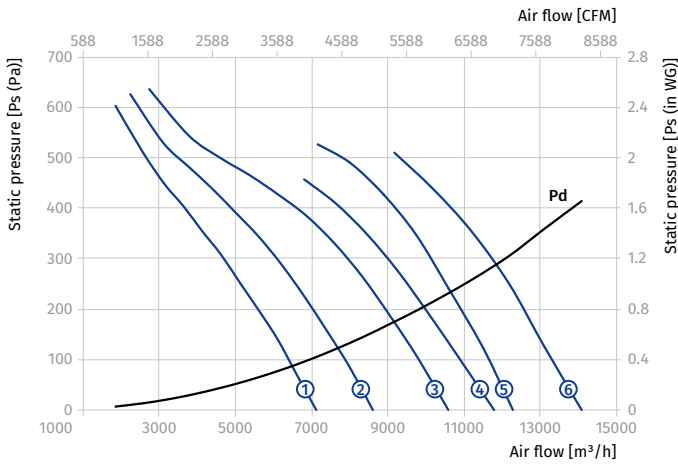

Standard size: 450
 Number of poles: 4
 Fire resistance rating: 300/2

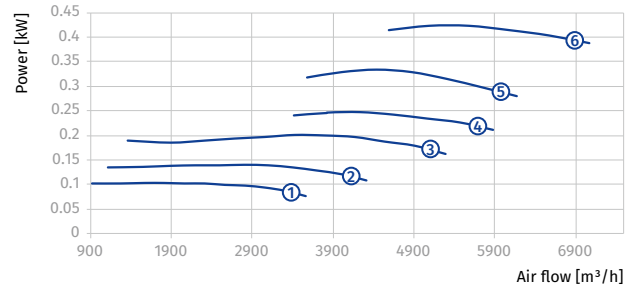
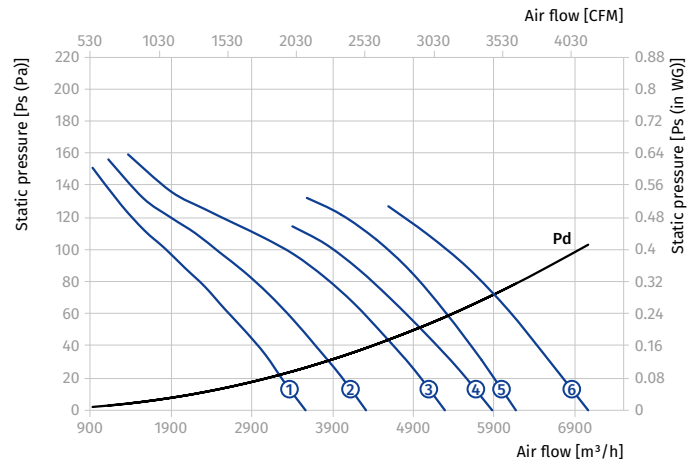

AXIS-FP 500...300/2

Size	Number of poles	Voltage [V/50 Hz]	Fan model	Installed motor power Ny [kW]	RPM [min ⁻¹]	Number of blades	Blade setting angle [°]	Weight [kg]	Length L [mm]	Curve number on graph
Axis-FP 500-2D...300/2										
500	2	3~400	Axis-FP 500-2D/1.1-6/25/AL	1.1	2880	6	25	32.0	400	①
			Axis-FP 500-2D/1.5-6/30/AL	1.5	2880	6	30	33.5	400	②
			Axis-FP 500-2D/2.2-6/35/AL	2.2	2880	6	35	36.0	400	③
			Axis-FP 500-2D/3-8/35/AL	3	2880	8	35	43.0	400	④
			Axis-FP 500-2D/4-8/40/AL	4	2880	8	40	55.0	500	⑤
			Axis-FP 500-2D/5.5-8/45/AL	5.5	2880	8	45	63	500	⑥
Axis-FP 500-4D...300/2										
500	4	3~400	Axis-FP 500-4D/0.55-6/25/AL	0.55	1440	6	25	28.0	400	①
			Axis-FP 500-4D/0.55-6/30/AL	0.55	1440	6	30	28.0	400	②
			Axis-FP 500-4D/0.55-6/35/AL	0.55	1440	6	35	28.0	400	③
			Axis-FP 500-4D/0.55-6/40/AL	0.55	1440	6	40	28.0	400	④
			Axis-FP 500-4D/0.55-6/45/AL	0.55	1440	6	45	28.0	400	⑤
			Axis-FP 500-4D/0.75-8/45/AL	0.75	1440	8	45	29.5	400	⑥

Standard size: 500
Number of poles: 2
Fire resistance rating: 300/2

Standard size: 500
Number of poles: 4
Fire resistance rating: 300/2

AXIAL SMOKE EXTRACTION FANS

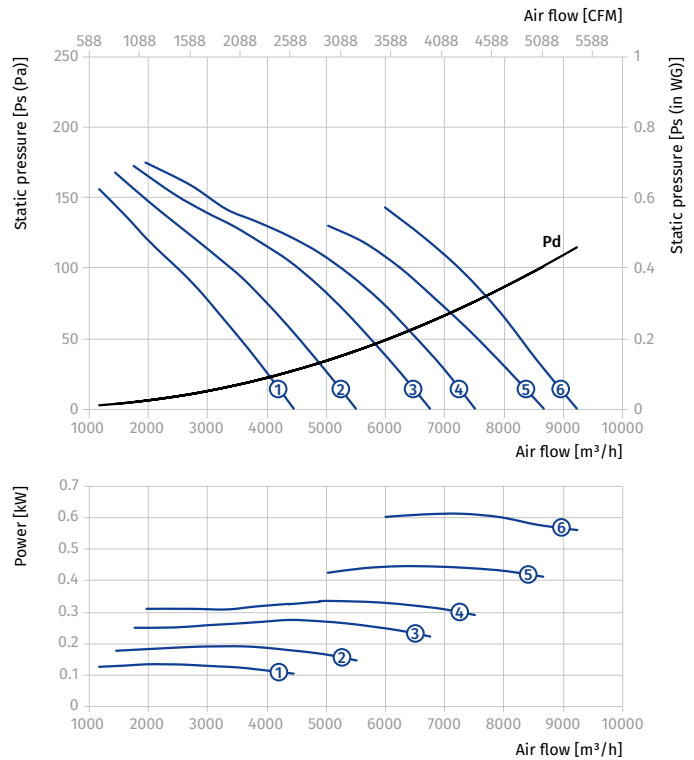
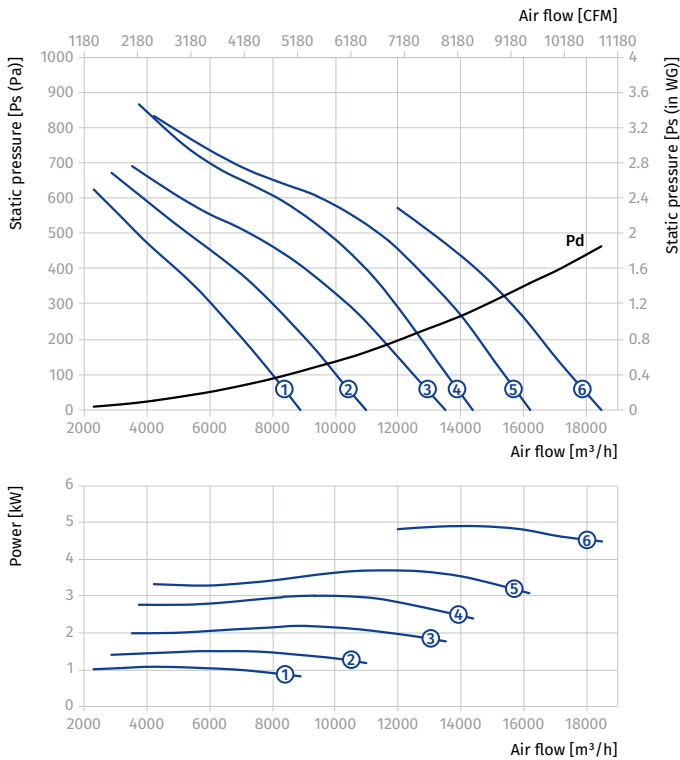

AXIS-FP 500...300/2

Size	Number of poles	Voltage [V/50 Hz]	Fan model	Installed motor power N_y [kW]	RPM [min^{-1}]	Number of blades	Blade setting angle [°]	Weight [kg]	Length L [mm]	Curve number on graph
Axis-FP 500-2/4D...300/2										
500	2/4	3~400	Axis-FP 500-2/4D/1.1/0.25-6/25/AL	1.1/0.25	2880/1440	6	25	33.5	400	①
			Axis-FP 500-2/4D/1.5/0.37-6/30/AL	1.5/0.37	2880/1440	6	30	39	400	②
			Axis-FP 500-2/4D/2.2/0.5-6/35/AL	2.2/0.5	2880/1440	6	35	41	400	③
			Axis-FP 500-2/4D/3.1/0.8-8/35/AL	3.1/0.8	2880/1440	8	35	54	500	④
			Axis-FP 500-2/4D/4.4/1.1-8/40/AL	4.4/1.1	2880/1440	8	40	66	500	⑤
			Axis-FP 500-2/4D/6/1.5-8/45/AL	6/1.5	2880/1440	8	45	85	550	⑥

Standard size: 500
 Number of poles: 2
 Fire resistance rating: 300/2

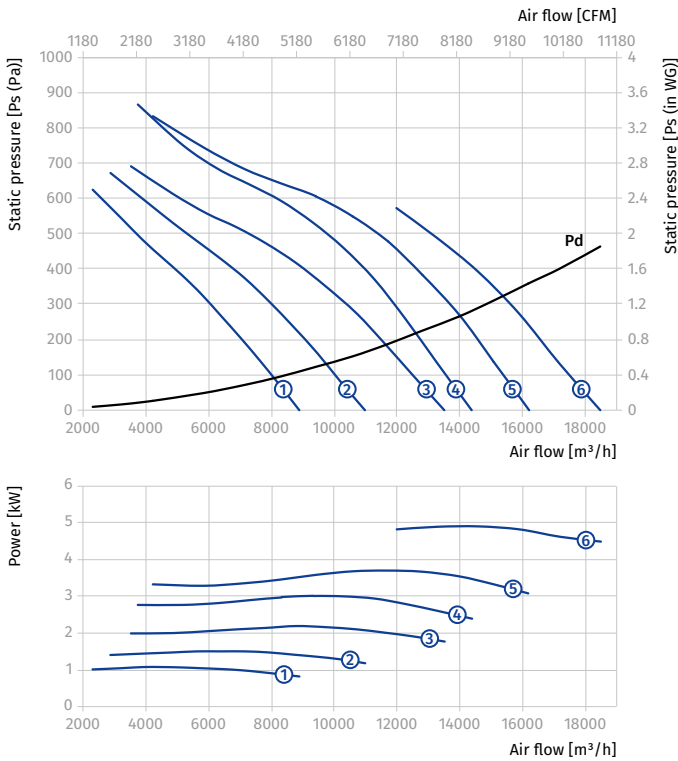

Standard size: 500
 Number of poles: 4
 Fire resistance rating: 300/2

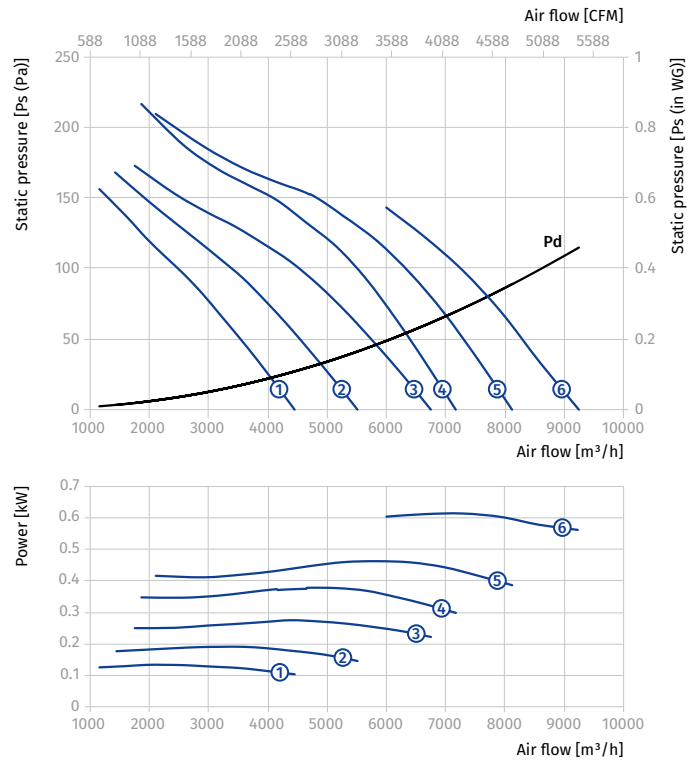

AXIS-FP 560...300/2

Size	Number of poles	Voltage [V/50 Hz]	Fan model	Installed motor power Ny [kW]	RPM [min ⁻¹]	Number of blades	Blade setting angle [°]	Weight [kg]	Length L [mm]	Curve number on graph
Axis-FP 560-2D...300/2										
560	2	3~400	Axis-FP 560-2D/1.1-6/25/AL	1.1	2880	6	25	34	400	①
			Axis-FP 560-2D/1.5-6/30/AL	1.5	2880	6	30	35.5	400	②
			Axis-FP 560-2D/2.2-8/30/AL	2.2	2880	8	30	38	400	③
			Axis-FP 560-2D/4-8/35/AL	4	2880	8	35	57.5	500	④
			Axis-FP 560-2D/5.5-8/40/AL	5.5	2880	8	40	65.5	500	⑤
			Axis-FP 560-2D/7.5-8/45/AL	7.5	2880	8	45	67.5	500	⑥
Axis-FP 560-4D...300/2										
560	4	3~400	Axis-FP 560-4D/0.55-6/25/AL	0.55	1440	6	25	30	400	①
			Axis-FP 560-4D/0.55-6/30/AL	0.55	1440	6	30	30	400	②
			Axis-FP 560-4D/0.55-6/35/AL	0.55	1440	6	35	30	400	③
			Axis-FP 560-4D/0.55-6/40/AL	0.55	1440	6	40	30	400	④
			Axis-FP 560-4D/0.55-6/45/AL	0.55	1440	6	45	30	400	⑤
			Axis-FP 560-4D/0.75-8/45/AL	0.75	1440	8	45	31.5	400	⑥

Standard size: 560
Number of poles: 2
Fire resistance rating: 300/2

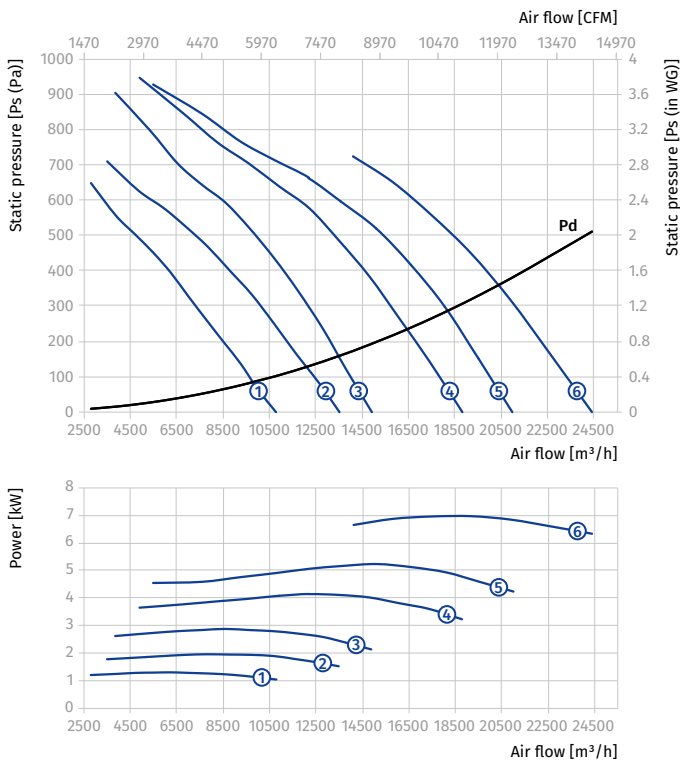

Standard size: 560
Number of poles: 4
Fire resistance rating: 300/2

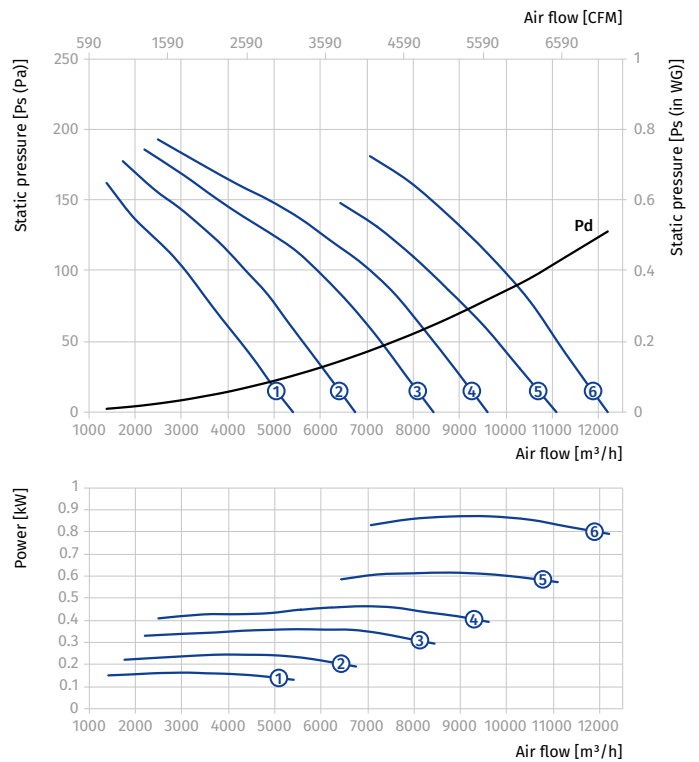

AXIS-FP 560...300/2

Size	Number of poles	Voltage [V/50 Hz]	Fan model	Installed motor power N_y [kW]	RPM [min^{-1}]	Number of blades	Blade setting angle [°]	Weight [kg]	Length L [mm]	Curve number on graph
Axis-FP 560-2/4D...300/2										
560	2/4	3~400	Axis-FP 560-2/4D/1.1/0.25-6/25/AL	1.1/0.25	2880/1440	6	25	35.5	400	①
			Axis-FP 560-2/4D/1.5/0.37-6/30/AL	1.5/0.37	2880/1440	6	30	41	400	②
			Axis-FP 560-2/4D/2.2/0.5-8/30/AL	2.2/0.5	2880/1440	8	30	43.5	400	③
			Axis-FP 560-2/4D/4.4/1.1-8/35/AL	4.4/1.1	2880/1440	8	35	68.5	500	④
			Axis-FP 560-2/4D/6/1.5-8/40/AL	6/1.5	2880/1440	8	40	96.5	550	⑤
			Axis-FP 560-2/4D/8/2-8/45/AL	8/2	2880/1440	8	45	105.5	550	⑥

Standard size: 560
 Number of poles: 2
 Fire resistance rating: 300/2

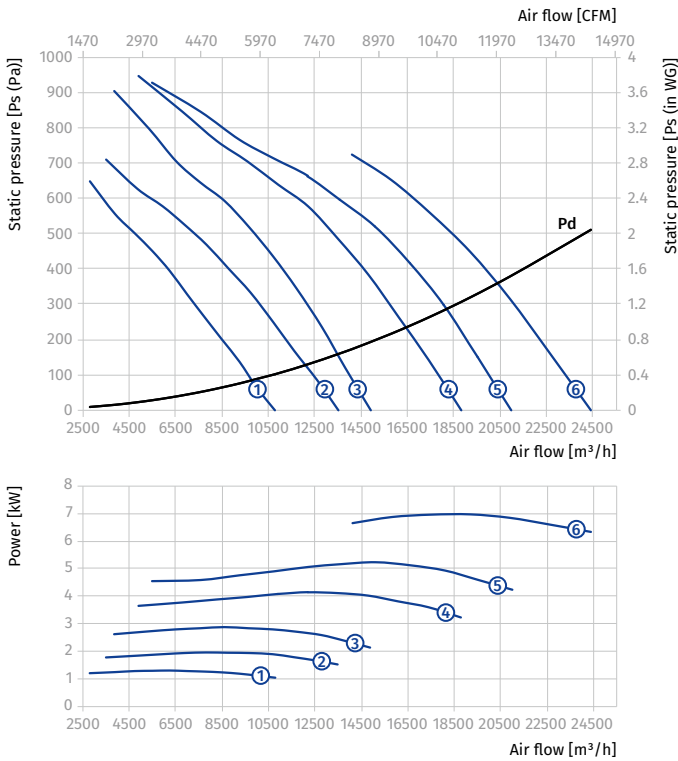

Standard size: 560
 Number of poles: 4
 Fire resistance rating: 300/2

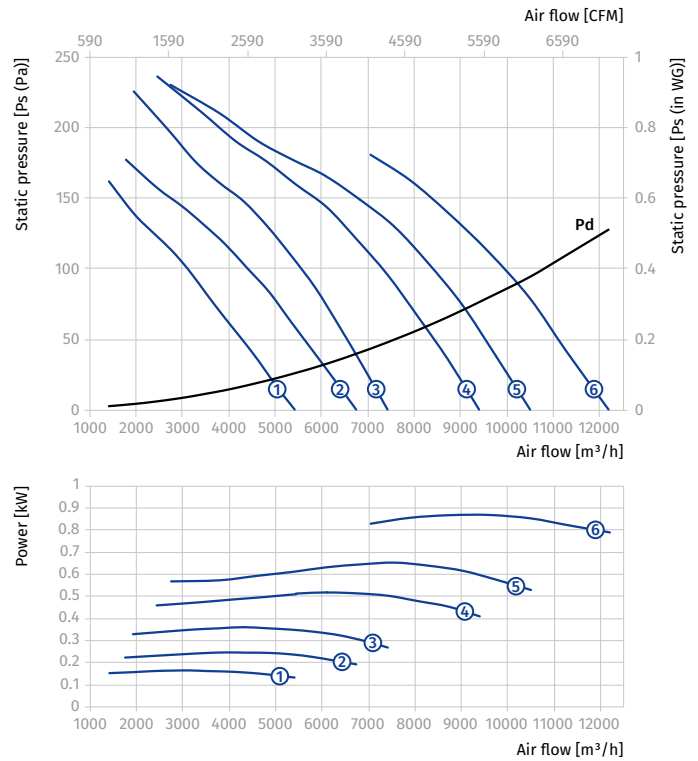

AXIS-FP 630...300/2

Size	Number of poles	Voltage [V/50 Hz]	Fan model	Installed motor power Ny [kW]	RPM [min ⁻¹]	Number of blades	Blade setting angle [°]	Weight [kg]	Length L [mm]	Curve number on graph
Axis-FP 630-2D...300/2										
630	2	3~400	Axis-FP 630-2D/2.2-6/25/AL	2.2	2880	6	25	41.5	400	①
			Axis-FP 630-2D/3-6/30/AL	3	2880	6	30	48	400	②
			Axis-FP 630-2D/4-7/32.5/AL	4	2880	7	32.5	61.5	500	③
			Axis-FP 630-2D/5.5-7/35/AL	5.5	2880	7	35	70	500	④
			Axis-FP 630-2D/5.5-7/37.5/AL	5.5	2880	7	37.5	70	500	⑤
			Axis-FP 630-2D/7.5-7/41.5/AL	7.5	2880	7	41.5	71.5	500	⑥
			Axis-FP 630-2D/11-8/41.5/AL	11	2880	8	41.5	119.5	550	⑦
			Axis-FP 630-2D/15-8/46.5/AL	15	2880	8	46.5	167	700	⑧
			Axis-FP 630-2D/15-9/48.5/AL	15	2880	9	48.5	166	700	⑨
Axis-FP 630-4D...300/2										
630	4	3~400	Axis-FP 630-4D/0.55-8/25/AL	0.55	1440	8	25	31.5	400	①
			Axis-FP 630-4D/0.55-8/30/AL	0.55	1440	8	30	31.5	400	②
			Axis-FP 630-4D/0.75-8/35/AL	0.75	1440	8	35	32.5	400	③
			Axis-FP 630-4D/1.1-8/40/AL	1.1	1440	8	40	36.5	400	④
			Axis-FP 630-4D/1.1-6/32.5/AL	1.1	1440	6	32.5	38.5	400	⑤
			Axis-FP 630-4D/1.5-6/37.5/AL	1.5	1440	6	37.5	42.5	400	⑥
			Axis-FP 630-4D/2.2-6/45/AL	2.2	1440	6	45	48.5	400	⑦

Standard size: 630
Number of poles: 2
Fire resistance rating: 300/2

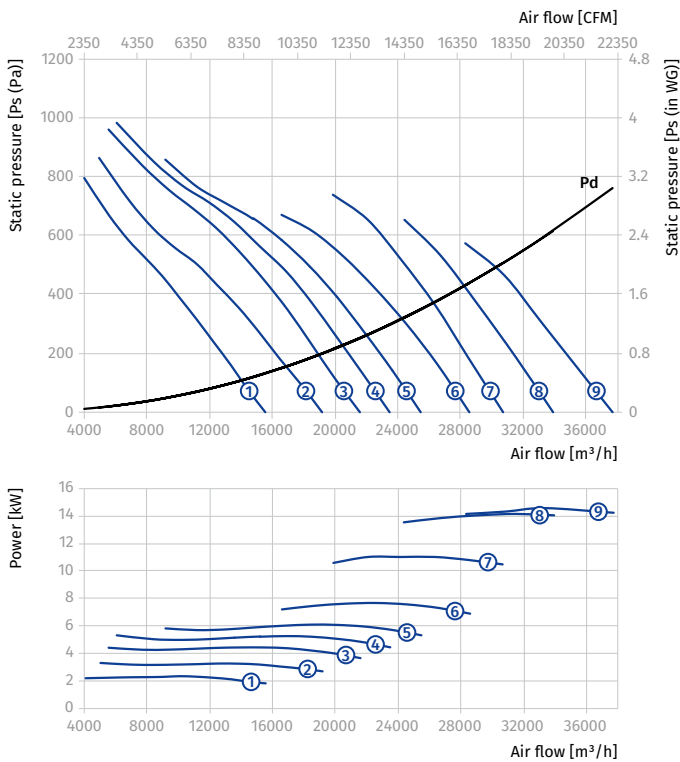

Standard size: 630
Number of poles: 4
Fire resistance rating: 300/2

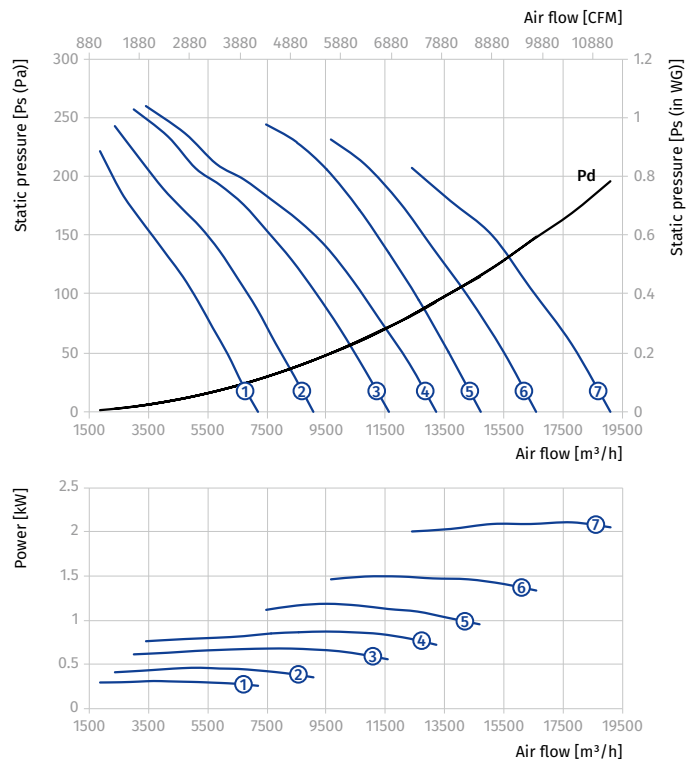

AXIS-FP 630...300/2

Size	Number of poles	Voltage [V/50 Hz]	Fan model	Installed motor power N _y [kW]	RPM [min ⁻¹]	Number of blades	Blade setting angle [°]	Weight [kg]	Length L [mm]	Curve number on graph
Axis-FP 630-2/4D...300/2										
630	2/4	3~400	Axis-FP 630-2/4D/2.2/0.5-6/25/AL	2.2/0.5	2880/1440	6	25	46.5	400	①
			Axis-FP 630-2/4D/3.1/0.8-6/30/AL	3.1/0.8	2880/1440	6	30	60	500	②
			Axis-FP 630-2/4D/4.4/1.1-7/32.5/AL	4.4/1.1	2880/1440	7	32.5	72.5	500	③
			Axis-FP 630-2/4D/6/1.5-7/35/AL	6/1.5	2880/1440	7	35	102	550	④
			Axis-FP 630-2/4D/6/1.5-7/37.5/AL	6/1.5	2880/1440	7	37.5	102	550	⑤
			Axis-FP 630-2/4D/8/2-7/41.5/AL	8/2	2880/1440	7	41.5	111	550	⑥
			Axis-FP 630-2/4D/12/3-8/41.5/AL	12/3	2880/1440	8	41.5	177	700	⑦
			Axis-FP 630-2/4D/16/4-8/46.5/AL	16/4	2880/1440	8	46.5	194	700	⑧
			Axis-FP 630-2/4D/16/4-9/48.5/AL	16/4	2880/1440	9	48.5	195	700	⑨

Standard size: 630
 Number of poles: 2
 Fire resistance rating: 300/2

Standard size: 630
 Number of poles: 4
 Fire resistance rating: 300/2

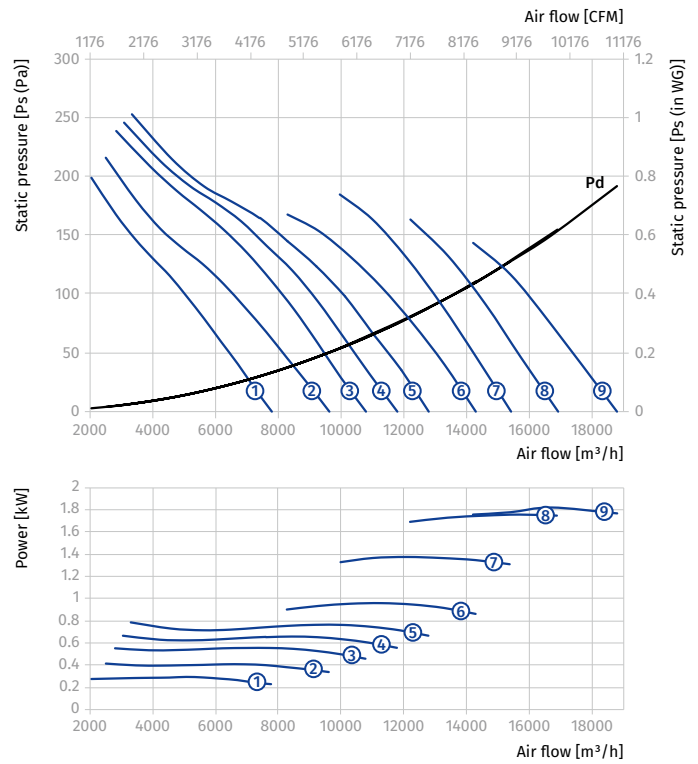
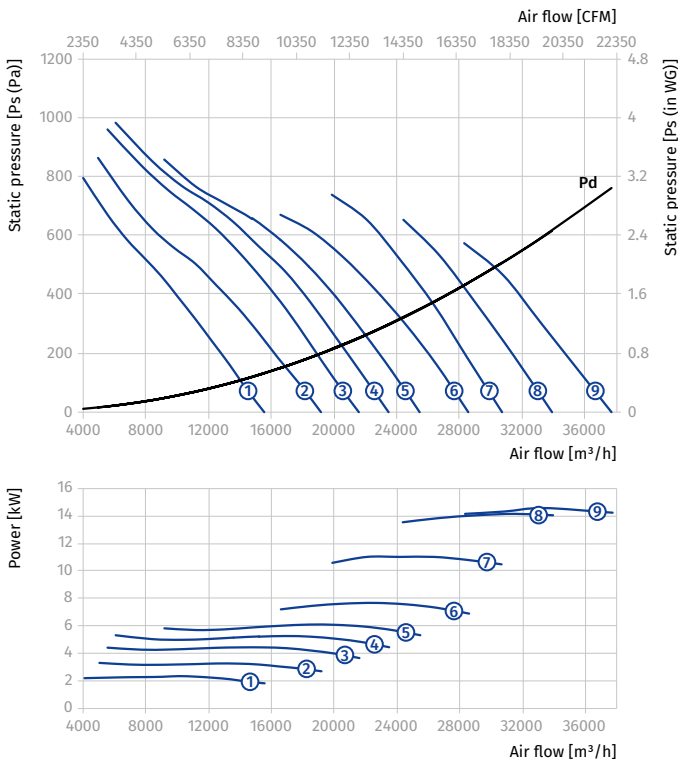

AXIS-FP 630...300/2

Size	Number of poles	Voltage [V/50 Hz]	Fan model	Installed motor power Ny [kW]	RPM [min ⁻¹]	Number of blades	Blade setting angle [°]	Weight [kg]	Length L [mm]	Curve number on graph
Axis-FP 630-4/6D...300/2										
630	4/6	3~400	Axis-FP 630-4/6D/0.55/0.2-8/25/AL	0.55/0.2	1440/960	8	25	34	400	①
			Axis-FP 630-4/6D/0.55/0.2-8/30/AL	0.55/0.2	1440/960	8	30	34	400	②
			Axis-FP 630-4/6D/0.75/0.25-8/35/AL	0.75/0.25	1440/960	8	35	34	400	③
			Axis-FP 630-4/6D/1.1/0.3-8/40/AL	1.1/0.3	1440/960	8	40	39.5	400	④
			Axis-FP 630-4/6D/1.1/0.3-6/32.5/AL	1.1/0.3	1440/960	6	32.5	42	400	⑤
			Axis-FP 630-4/6D/1.5/0.37-6/37.5/AL	1.5/0.37	1440/960	6	37.5	46	400	⑥
			Axis-FP 630-4/6D/2.2/0.7-6/45/AL	2.2/0.7	1440/960	6	45	57	500	⑦

Standard size: 630
Number of poles: 4
Fire resistance rating: 300/2

Standard size: 630
Number of poles: 6
Fire resistance rating: 300/2

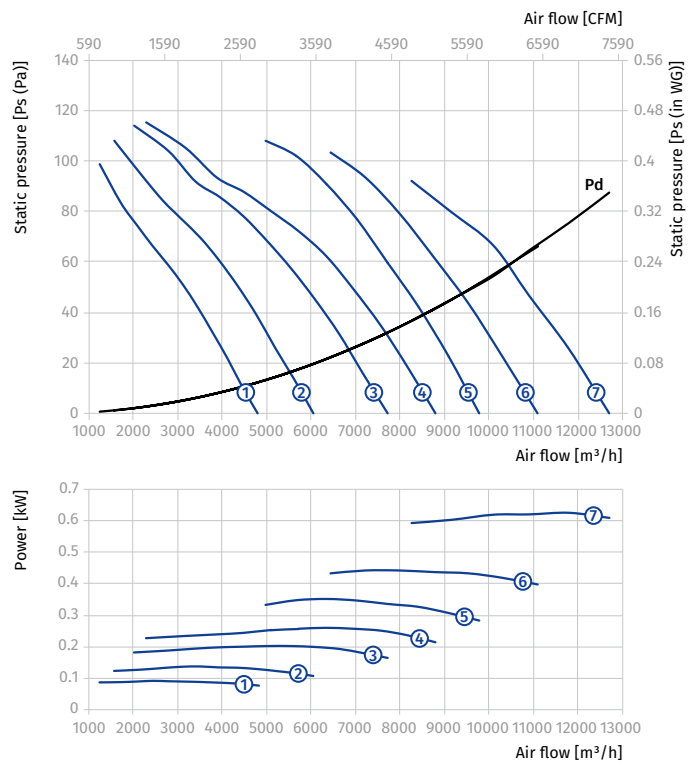
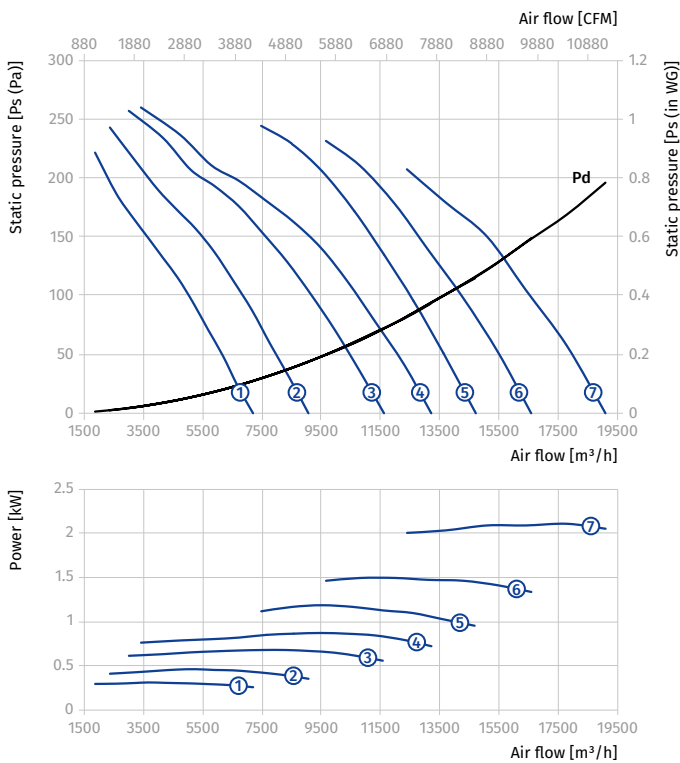

AXIS-FP 630...300/2

Size	Number of poles	Voltage [V/50 Hz]	Fan model	Installed motor power Ny [kW]	RPM [min ⁻¹]	Number of blades	Blade setting angle [°]	Weight [kg]	Length L [mm]	Curve number on graph
Axis-FP 630-4/8D...300/2										
630	4/8	3~400	Axis-FP 630-4/8D/0.6/0.15-8/25/AL	0.6/0.15	1440/720	8	25	38	400	①
			Axis-FP 630-4/8D/0.6/0.15-8/30/AL	0.6/0.15	1440/720	8	30	38	400	②
			Axis-FP 630-4/8D/0.8/0.2-8/35/AL	0.8/0.2	1440/720	8	35	38	400	③
			Axis-FP 630-4/8D/1.2/0.3-8/40/AL	1.2/0.3	1440/720	8	40	43.5	400	④
			Axis-FP 630-4/8D/1.2/0.3-6/32.5/AL	1.2/0.3	1440/720	6	32.5	46	400	⑤
			Axis-FP 630-4/8D/1.6/0.4-6/37.5/AL	1.6/0.4	1440/720	6	37.5	49	400	⑥
			Axis-FP 630-4/8D/2.2/0.55-6/45/AL	2.2/0.55	1440/720	6	45	60	500	⑦

Standard size: 630
 Number of poles: 4
 Fire resistance rating: 300/2

Standard size: 630
 Number of poles: 8
 Fire resistance rating: 300/2

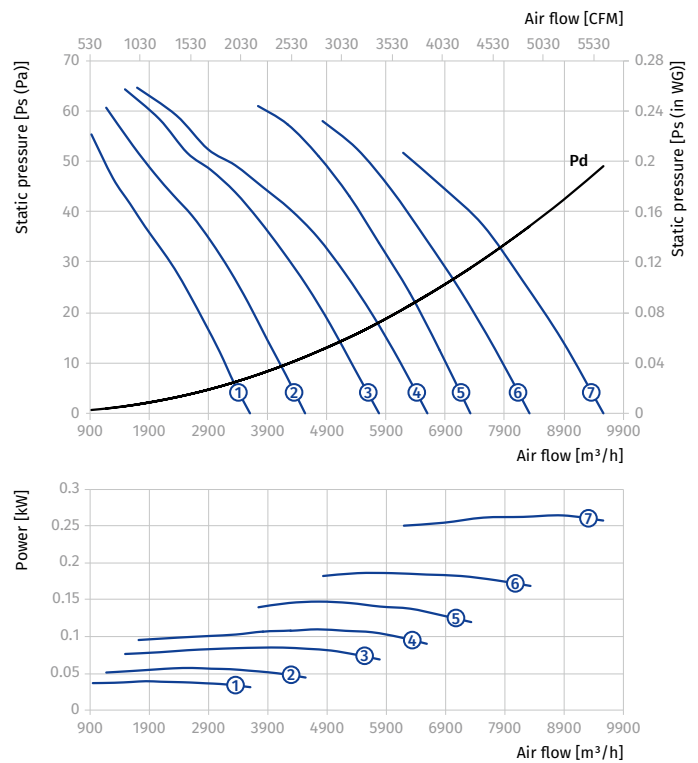
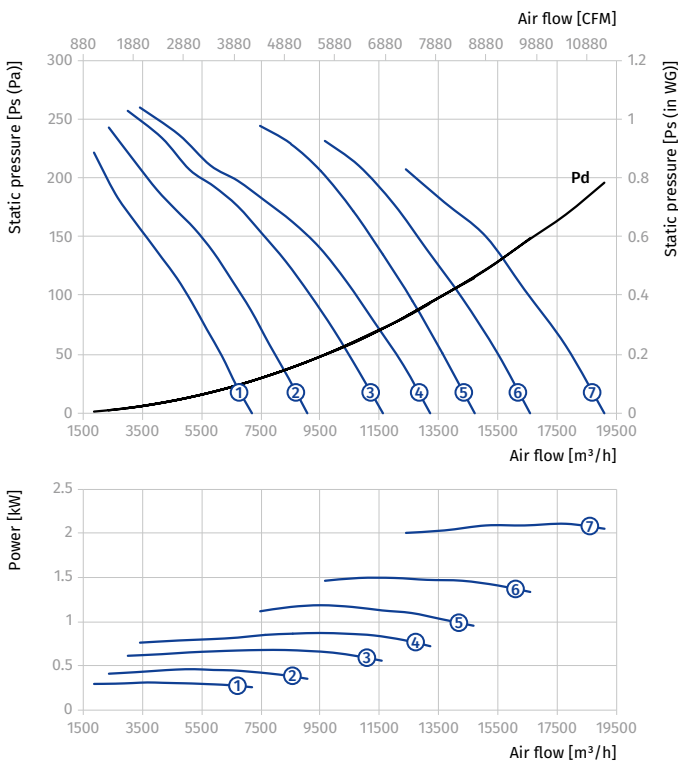

AXIS-FP 710...300/2

Size	Number of poles	Voltage [V/50 Hz]	Fan model	Installed motor power Ny [kW]	RPM [min ⁻¹]	Number of blades	Blade setting angle [°]	Weight [kg]	Length L [mm]	Curve number on graph
Axis-FP 710-4D...300/2										
710	4	3~400	Axis-FP 710-4D/0.75-6/20/AL	0.75	1440	6	20	47.5	400	①
			Axis-FP 710-4D/1.1-6/25/AL	1.1	1440	6	25	51.5	400	②
			Axis-FP 710-4D/1.5-6/30/AL	1.5	1440	6	30	55	400	③
			Axis-FP 710-4D/2.2-6/35/AL	2.2	1440	6	35	61	400	④
			Axis-FP 710-4D/2.2-6/40/AL	2.2	1440	6	40	61	400	⑤
			Axis-FP 710-4D/3-6/45/AL	3	1440	6	45	75	500	⑥
Axis-FP 710-6D...300/2										
710	6	3~400	Axis-FP 710-6D/0.25-6/20/AL	0.25	960	6	20	45.5	400	①
			Axis-FP 710-6D/0.25-6/25/AL	0.25	960	6	25	45.5	400	②
			Axis-FP 710-6D/0.37-6/30/AL	0.37	960	6	30	49.5	400	③
			Axis-FP 710-6D/0.55-6/35/AL	0.55	960	6	35	53	400	④
			Axis-FP 710-6D/0.75-6/40/AL	0.75	960	6	40	56	400	⑤
			Axis-FP 710-6D/1.1-6/45/AL	1.1	960	6	45	60	400	⑥

Standard size: 710
Number of poles: 4
Fire resistance rating: 300/2

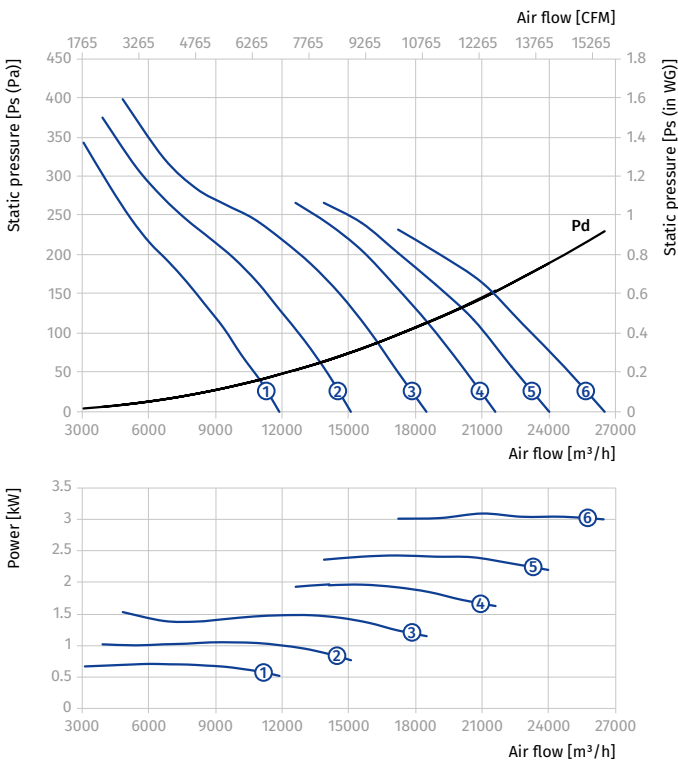

Standard size: 710
Number of poles: 6
Fire resistance rating: 300/2

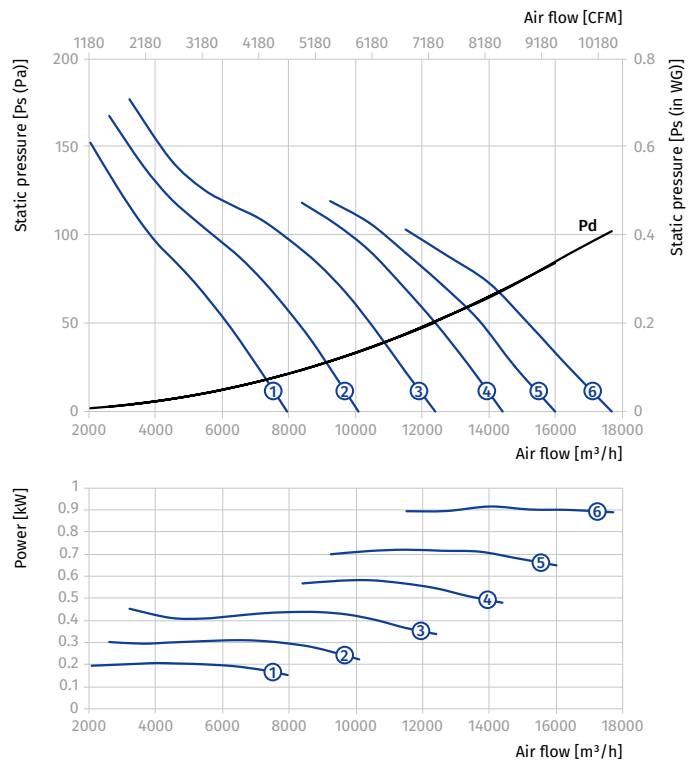

AXIS-FP 710...300/2

Size	Number of poles	Voltage [V/50 Hz]	Fan model	Installed motor power N_y [kW]	RPM [min^{-1}]	Number of blades	Blade setting angle [°]	Weight [kg]	Length L [mm]	Curve number on graph
Axis-FP 710-4/6D...300/2										
710	4/6	3~400	Axis-FP 710-4/6D/0.75/0.25-6/20/AL	0.75/0.25	1440/960	6	20	49	400	①
			Axis-FP 710-4/6D/1.1/0.3-6/25/AL	1.1/0.3	1440/960	6	25	54	400	②
			Axis-FP 710-4/6D/1.5/0.37-6/30/AL	1.5/0.37	1440/960	6	30	58	400	③
			Axis-FP 710-4/6D/2.2/0.7-6/35/AL	2.2/0.7	1440/960	6	35	72	500	④
			Axis-FP 710-4/6D/2.2/0.7-6/40/AL	2.2/0.7	1440/960	6	40	72	500	⑤
			Axis-FP 710-4/6D/3/1-6/45/AL	3/1	1440/960	6	45	81	500	⑥

Standard size: 710
 Number of poles: 4
 Fire resistance rating: 300/2

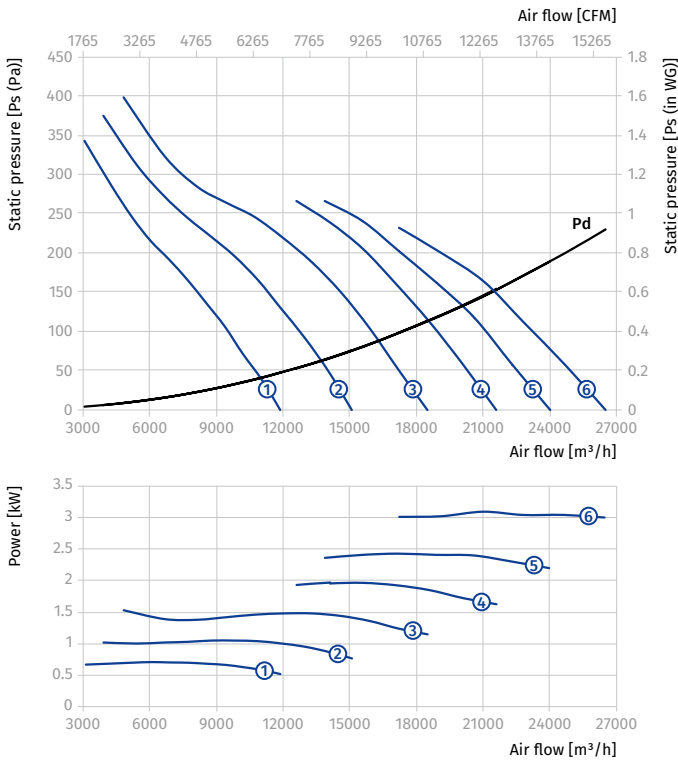

Standard size: 710
 Number of poles: 6
 Fire resistance rating: 300/2

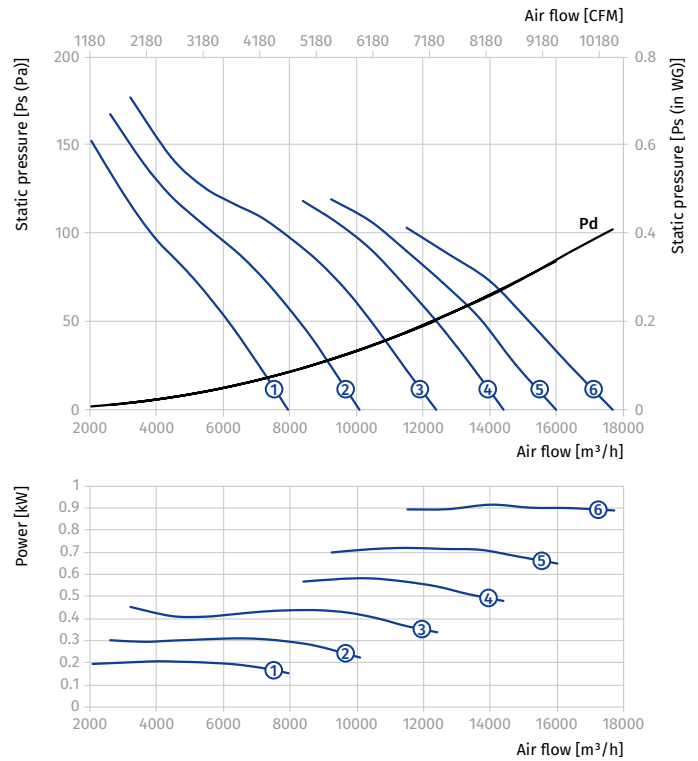

AXIS-FP 710...300/2

Size	Number of poles	Voltage [V/50 Hz]	Fan model	Installed motor power Ny [kW]	RPM [min ⁻¹]	Number of blades	Blade setting angle [°]	Weight [kg]	Length L [mm]	Curve number on graph
Axis-FP 710-4/8D...300/2										
710	4/8	3~400	Axis-FP 710-4/8D/0.8/0.2-6/20/AL	0.8/0.2	1440/720	6	20	52	400	①
			Axis-FP 710-4/8D/1.2/0.3-6/25/AL	1.2/0.3	1440/720	6	25	58	400	②
			Axis-FP 710-4/8D/1.6/0.4-6/30/AL	1.6/0.4	1440/720	6	30	61	400	③
			Axis-FP 710-4/8D/2.2/0.55-6/35/AL	2.2/0.55	1440/720	6	35	75	500	④
			Axis-FP 710-4/8D/2.2/0.55-6/40/AL	2.2/0.55	1440/720	6	40	75	500	⑤
			Axis-FP 710-4/8D/2.8/0.7-6/45/AL	2.8/0.7	1440/720	6	45	78	500	⑥

Standard size: 710
Number of poles: 4
Fire resistance rating: 300/2

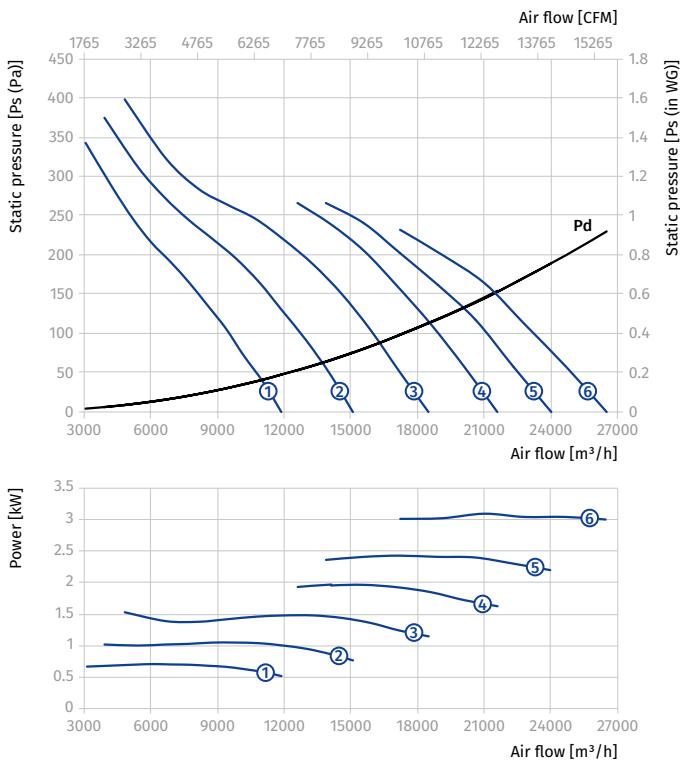

Standard size: 710
Number of poles: 8
Fire resistance rating: 300/2

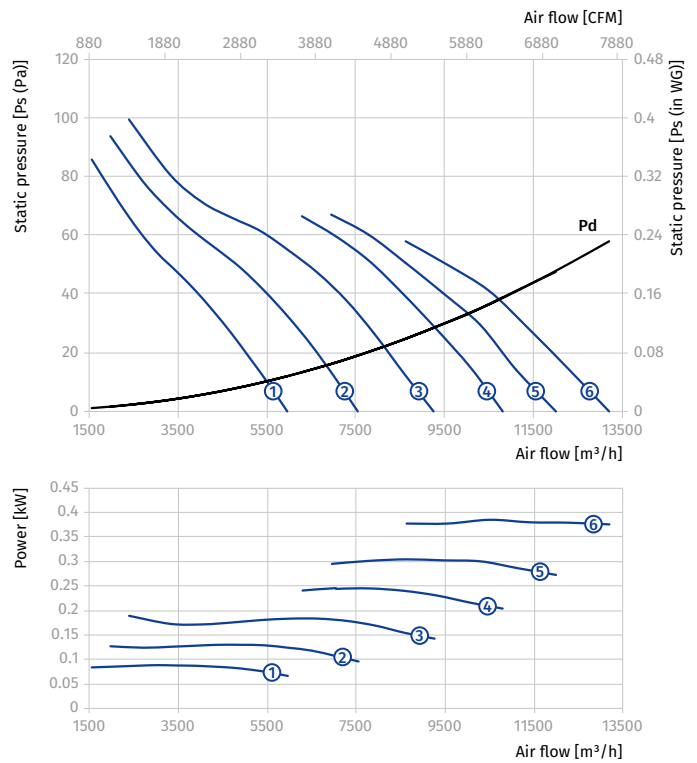

AXIS-FP 800...300/2

Size	Number of poles	Voltage [V/50 Hz]	Fan model	Installed motor power N_y [kW]	RPM [min^{-1}]	Number of blades	Blade setting angle [°]	Weight [kg]	Length L [mm]	Curve number on graph
Axis-FP 800-4D...300/2										
800	4	3~400	Axis-FP 800-4D/1.1-6/20/AL	1.1	1440	6	20	59.5	400	①
			Axis-FP 800-4D/1.5-6/25/AL	1.5	1440	6	25	65.5	400	②
			Axis-FP 800-4D/2.2-6/30/AL	2.2	1440	6	30	65.5	400	③
			Axis-FP 800-4D/3-6/32.5/AL	3	1440	6	32.5	80	500	④
			Axis-FP 800-4D/3-6/35/AL	3	1440	6	35	80	500	⑤
			Axis-FP 800-4D/4-6/37.5/AL	4	1440	6	37.5	85	500	⑥
			Axis-FP 800-4D/4-6/40/AL	4	1440	6	40	85	500	⑦
			Axis-FP 800-4D/5.5-6/45/AL	5.5	1440	6	45	104	550	⑧
Axis-FP 800-6D...300/2										
800	6	3~400	Axis-FP 800-6D/0.37-6/20/AL	0.37	960	6	20	53.5	400	①
			Axis-FP 800-6D/0.55-6/25/AL	0.55	960	6	25	56.5	400	②
			Axis-FP 800-6D/0.75-6/30/AL	0.75	960	6	30	60.5	400	③
			Axis-FP 800-6D/0.75-6/32.5/AL	0.75	960	6	32.5	60.5	400	④
			Axis-FP 800-6D/1.1-6/35/AL	1.1	960	6	35	64.5	400	⑤
			Axis-FP 800-6D/1.1-6/37.5/AL	1.1	960	6	37.5	64.5	400	⑥
			Axis-FP 800-6D/1.1-6/40/AL	1.1	960	6	40	64.5	400	⑦
			Axis-FP 800-6D/1.5-6/45/AL	1.5	960	6	45	77	500	⑧

Standard size: 800
 Number of poles: 4
 Fire resistance rating: 300/2

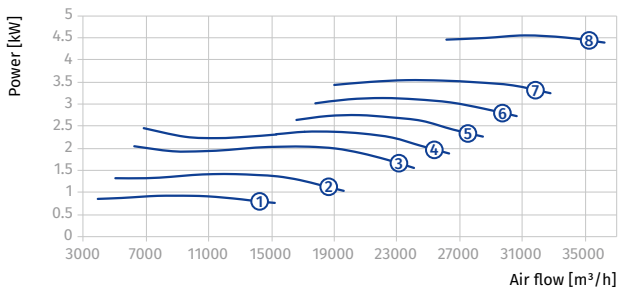
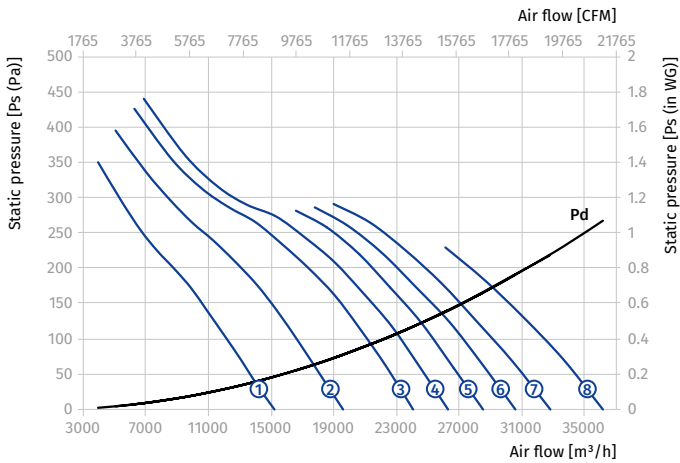

Standard size: 800
 Number of poles: 6
 Fire resistance rating: 300/2

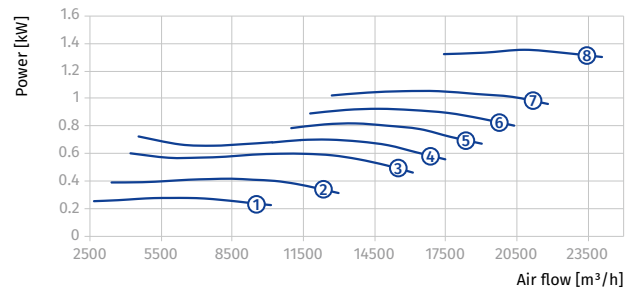
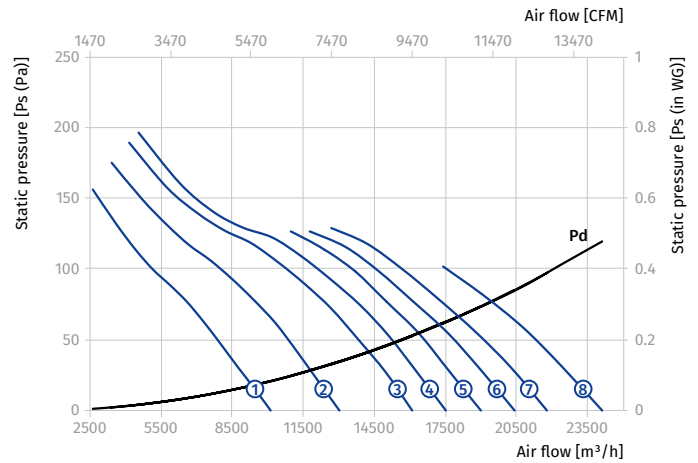

AXIS-FP 800...300/2

Size	Number of poles	Voltage [V/50 Hz]	Fan model	Installed motor power Ny [kW]	RPM [min ⁻¹]	Number of blades	Blade setting angle [°]	Weight [kg]	Length L [mm]	Curve number on graph
Axis-FP 800-4/6D...300/2										
800	4/6	3~400	Axis-FP 800-4/6D/1.1/0.3-6/20/AL	1.1/0.3	1440/960	6	20	58.5	400	①
			Axis-FP 800-4/6D/1.5/0.37-6/25/AL	1.5/0.37	1440/960	6	25	62.5	400	②
			Axis-FP 800-4/6D/2.2/0.7-6/30/AL	2.2/0.7	1440/960	6	30	77	500	③
			Axis-FP 800-4/6D/2.2/0.7-6/32.5/AL	2.2/0.7	1440/960	6	32.5	77	500	④
			Axis-FP 800-4/6D/3/1-6/35/AL	3/1	1440/960	6	35	88	500	⑤
			Axis-FP 800-4/6D/3/1-6/37.5/AL	3/1	1440/960	6	37.5	88	500	⑥
			Axis-FP 800-4/6D/4.5/1.5-6/45/AL	4.5/1.5	1440/960	6	45	125	550	⑦

Standard size: 800
Number of poles: 4
Fire resistance rating: 300/2

Standard size: 800
Number of poles: 6
Fire resistance rating: 300/2

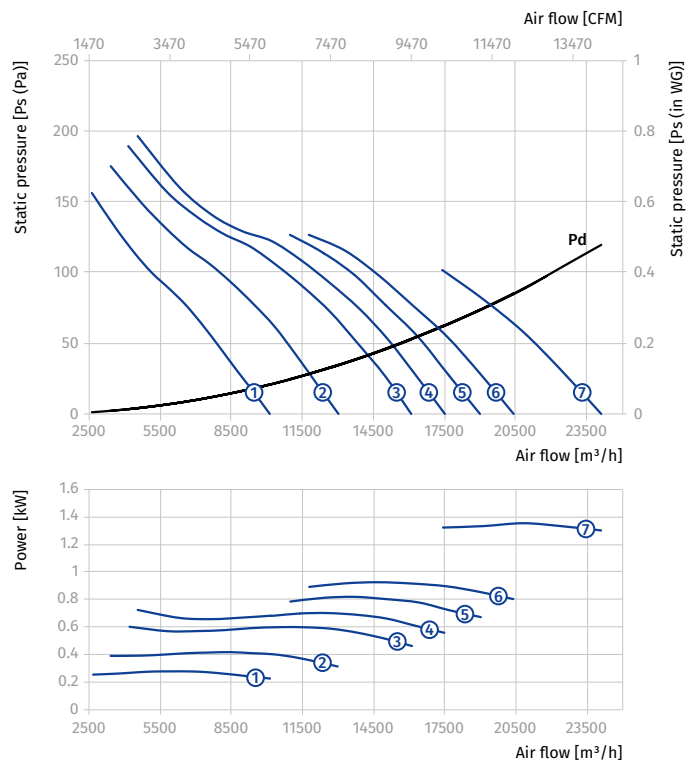
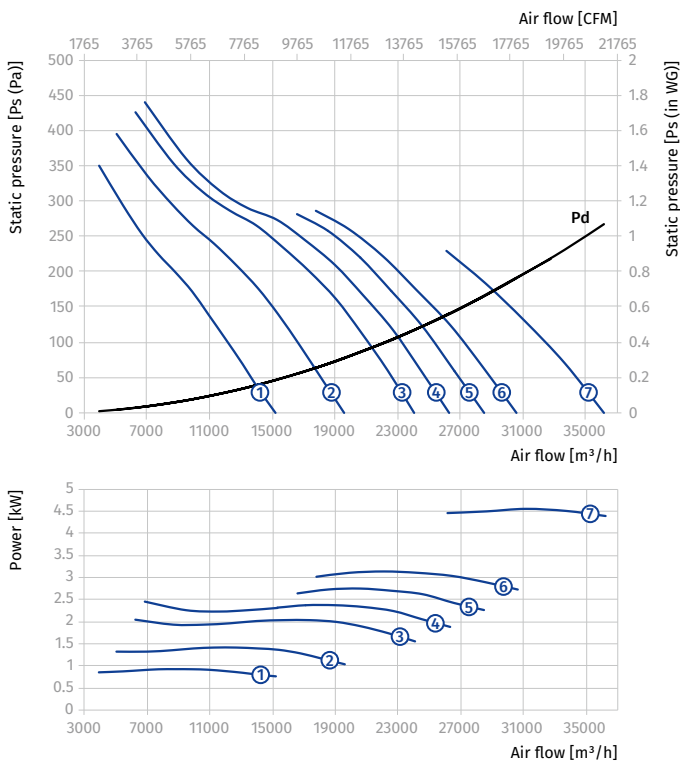

AXIS-FP 800...300/2

Size	Number of poles	Voltage [V/50 Hz]	Fan model	Installed motor power N _y [kW]	RPM [min ⁻¹]	Number of blades	Blade setting angle [°]	Weight [kg]	Length L [mm]	Curve number on graph
Axis-FP 800-4/8D...300/2										
800	4/8	3~400	Axis-FP 800-4/8D/1.2/0.3-6/20/AL	1.2/0.3	1440/720	6	20	62.5	400	①
			Axis-FP 800-4/8D/1.6/0.4-6/25/AL	1.6/0.4	1440/720	6	25	65.5	400	②
			Axis-FP 800-4/8D/2.2/0.55-6/30/AL	2.2/0.55	1440/720	6	30	80	500	③
			Axis-FP 800-4/8D/2.8/0.7-6/32.5/AL	2.8/0.7	1440/720	6	32.5	83	500	④
			Axis-FP 800-4/8D/2.8/0.7-6/35/AL	2.8/0.7	1440/720	6	35	83	500	⑤
			Axis-FP 800-4/8D/3.8/1-6/37.5/AL	3.8/1	1440/720	6	37.5	95	500	⑥
			Axis-FP 800-4/8D/3.8/1-6/40/AL	3.8/1	1440/720	6	40	95	500	⑦
			Axis-FP 800-4/8D/5/1.3-6/45/AL	5/1.3	1440/720	6	45	125	550	⑧

Standard size: **800**
 Number of poles: **4**
 Fire resistance rating: **300/2**

Standard size: **800**
 Number of poles: **8**
 Fire resistance rating: **300/2**

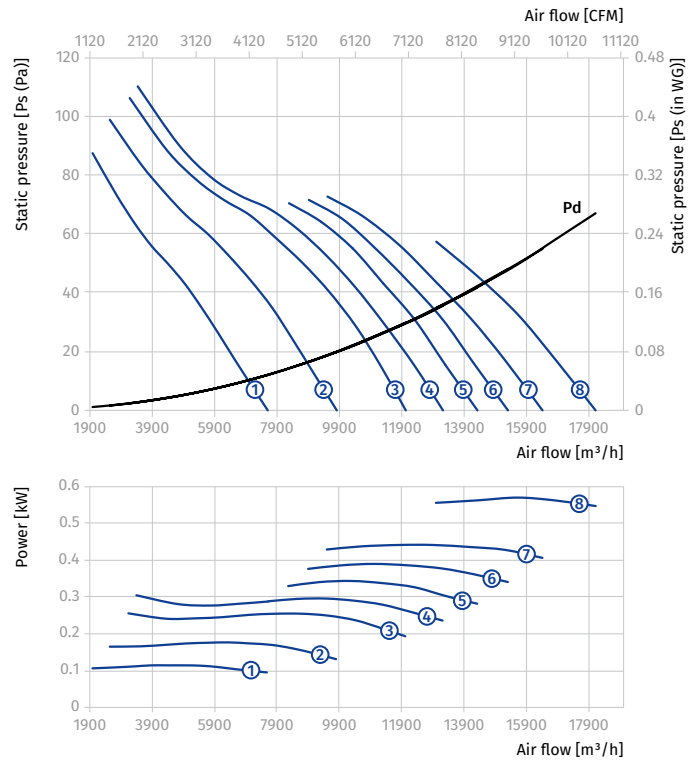
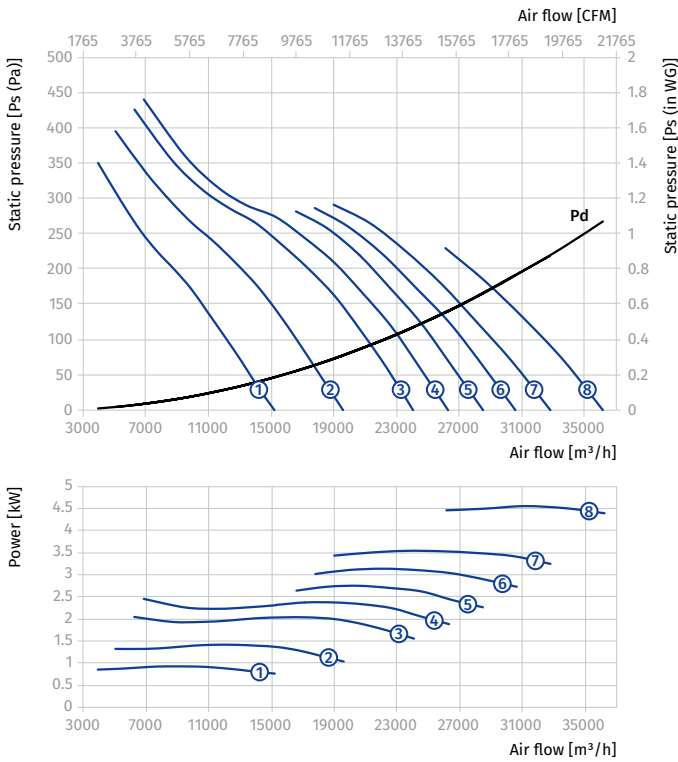

AXIAL SMOKE EXTRACTION FANS

AXIS-FP 900...300/2

Size	Number of poles	Voltage [V/50 Hz]	Fan model	Installed motor power Ny [kW]	RPM [min ⁻¹]	Number of blades	Blade setting angle [°]	Weight [kg]	Length L [mm]	Curve number on graph
Axis-FP 900-4D...300/2										
900	4	3~400	Axis-FP 900-4D/3-8/23.5/AL	3	1440	8	23.5	92	550	①
			Axis-FP 900-4D/4-8/28.5/AL	4	1440	8	28.5	97	550	②
			Axis-FP 900-4D/5.5-8/33.5/AL	5.5	1440	8	33.5	132.5	600	③
			Axis-FP 900-4D/7.5-8/40/AL	7.5	1440	8	40	150	600	④
			Axis-FP 900-4D/11-8/45/AL	11	1440	8	45	168.5	600	⑤
Axis-FP 900-6D...300/2										
900	6	3~400	Axis-FP 900-6D/0.75-8/23.5/AL	0.75	960	8	23.5	71.5	450	①
			Axis-FP 900-6D/1.1-8/28.5/AL	1.1	960	8	28.5	75.5	450	②
			Axis-FP 900-6D/1.5-8/33.5/AL	1.5	960	8	33.5	89	550	③
			Axis-FP 900-6D/2.2-8/41/AL	2.2	960	8	41	101	550	④
			Axis-FP 900-6D/3-8/45/AL	3	960	8	45	104.5	600	⑤

Standard size: 900
Number of poles: 4
Fire resistance rating: 300/2

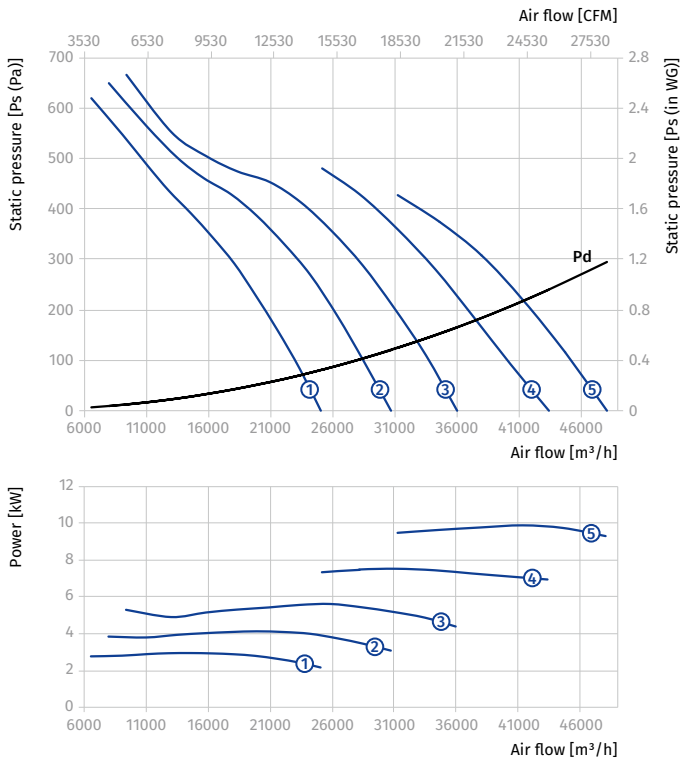

Standard size: 900
Number of poles: 6
Fire resistance rating: 300/2

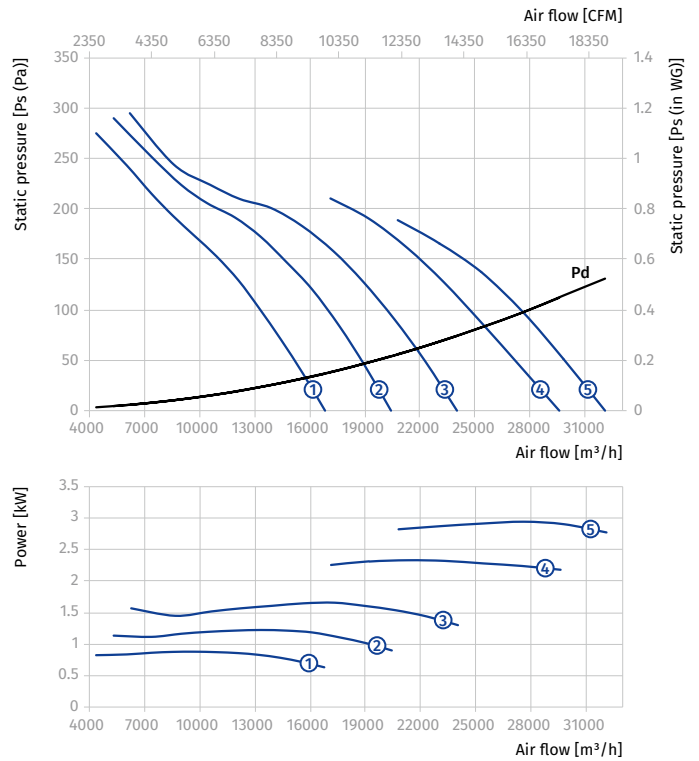

AXIS-FP 900...300/2

Size	Number of poles	Voltage [V/50 Hz]	Fan model	Installed motor power N_y [kW]	RPM [min^{-1}]	Number of blades	Blade setting angle [°]	Weight [kg]	Length L [mm]	Curve number on graph
Axis-FP 900-4/6D...300/2										
900	4/6	3~400	Axis-FP 900-4/6D/3/1-8/23.5/AL	3/1	1440/960	8	23.5	100	550	①
			Axis-FP 900-4/6D/4.5/1.5-8/28.5/AL	4.5/1.5	1440/960	8	28.5	153.5	600	②
			Axis-FP 900-4/6D/6/2.2-8/33.5/AL	6/2.2	1440/960	8	33.5	164.5	600	③
			Axis-FP 900-4/6D/10/3.3-8/45/AL	10/3.3	1440/960	8	45	227.5	750	④

Standard size: 900
 Number of poles: 4
 Fire resistance rating: 300/2

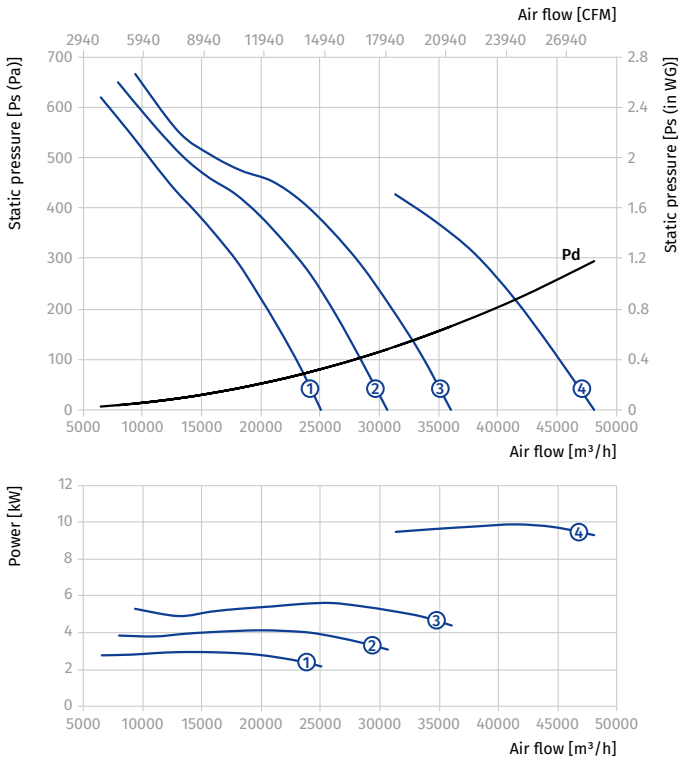

Standard size: 900
 Number of poles: 6
 Fire resistance rating: 300/2

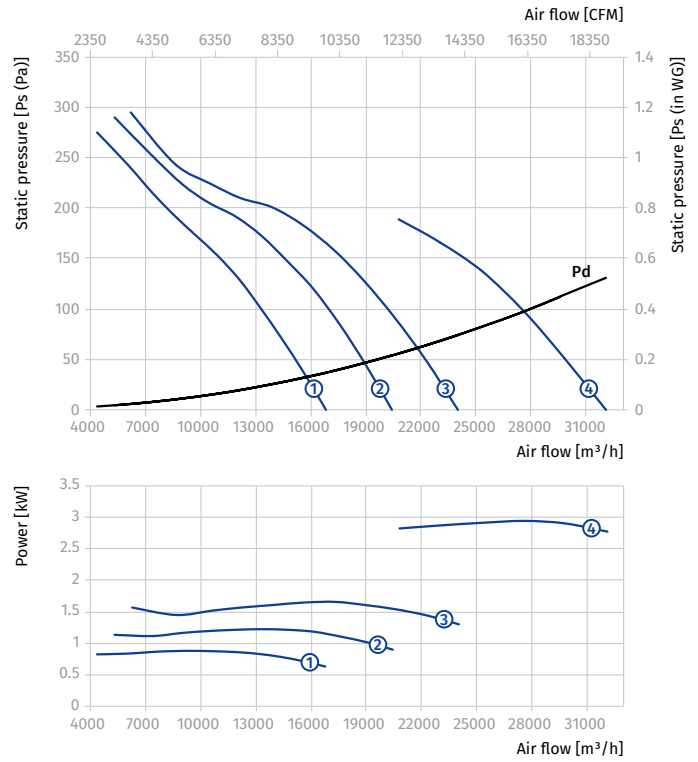

AXIAL SMOKE EXTRACTION FANS

AXIS-FP 900...300/2

Size	Number of poles	Voltage [V/50 Hz]	Fan model	Installed motor power Ny [kW]	RPM [min ⁻¹]	Number of blades	Blade setting angle [°]	Weight [kg]	Length L [mm]	Curve number on graph
Axis-FP 900-4/8D...300/2										
900	4/8	3~400	Axis-FP 900-4/8D/2.8/0.7-8/23.5/AL	2.8/0.7	1440/720	8	23.5	95	550	①
			Axis-FP 900-4/8D/3.8/1-8/28.5/AL	3.8/1	1440/720	8	28.5	107	550	②
			Axis-FP 900-4/8D/5/1.3-8/33.5/AL	5/1.3	1440/720	8	33.5	153.5	600	③
			Axis-FP 900-4/8D/7.2/1.8-8/40/AL	7.2/1.8	1440/720	8	40	165.5	600	④
			Axis-FP 900-4/8D/11/3-8/45/AL	11/3	1440/720	8	45	226.5	750	⑤

Standard size: **900**
Number of poles: **4**
Fire resistance rating: **300/2**

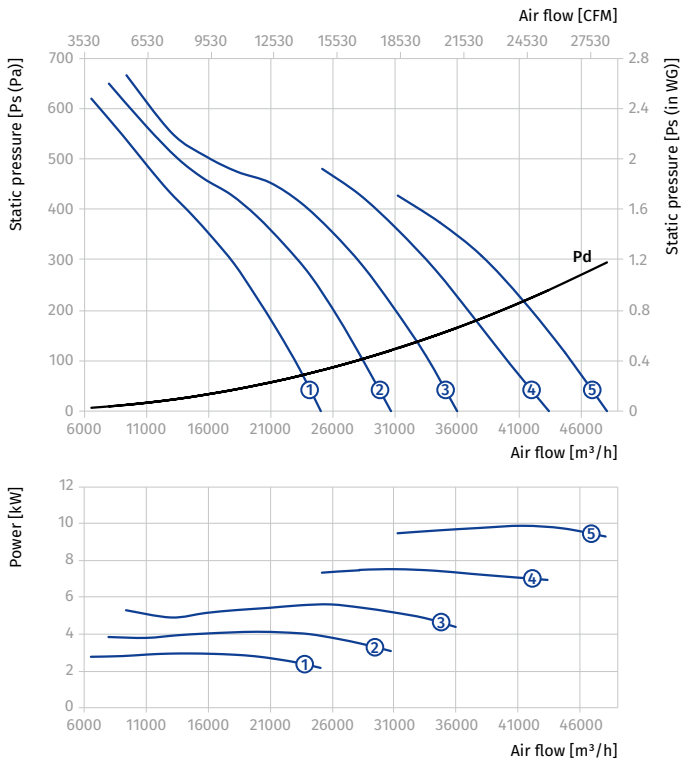

Standard size: **900**
Number of poles: **8**
Fire resistance rating: **300/2**

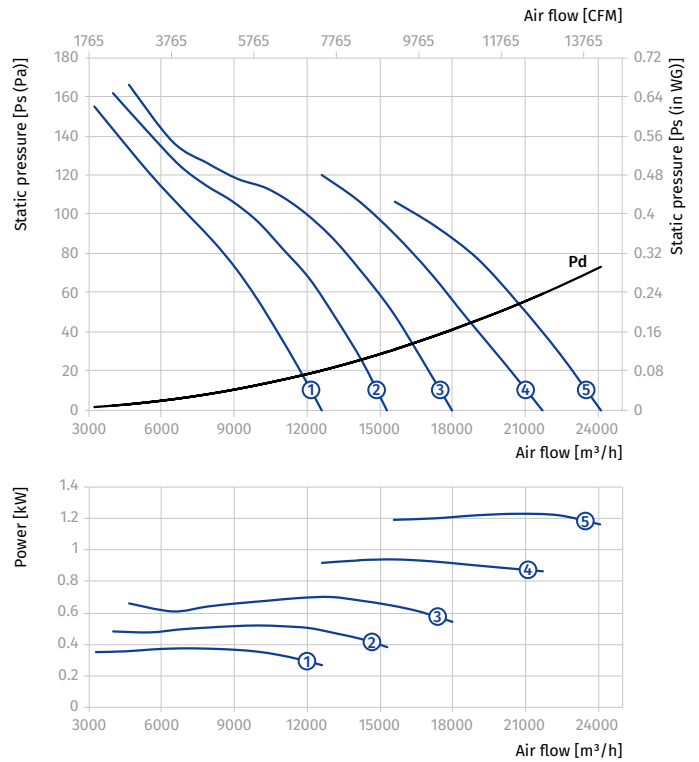

AXIS-FP 1000...300/2

Size	Number of poles	Voltage [V/50 Hz]	Fan model	Installed motor power Ny [kW]	RPM [min ⁻¹]	Number of blades	Blade setting angle [°]	Weight [kg]	Length L [mm]	Curve number on graph
Axis-FP 1000-4D...300/2										
1000	4	3~400	Axis-FP 1000-4D/5.5-6/24/AL	5.5	1440	6	24	147.5	600	①
			Axis-FP 1000-4D/7.5-6/30/AL	7.5	1440	6	30	165	600	②
			Axis-FP 1000-4D/9.2-6/33/AL	9.2	1440	6	33	170.5	600	③
			Axis-FP 1000-4D/11-6/36/AL	11	1440	6	36	183.5	600	④
			Axis-FP 1000-4D/15-6/43/AL	15	1440	6	43	244	750	⑤
			Axis-FP 1000-4D/18.5-6/48/AL	18.5	1440	6	48	259	750	⑥
Axis-FP 1000-6D...300/2										
1000	6	3~400	Axis-FP 1000-6D/1.5-6/23/AL	1.5	960	6	23	101	550	①
			Axis-FP 1000-6D/2.2-6/29/AL	2.2	960	6	29	114	550	②
			Axis-FP 1000-6D/3-6/35/AL	3	960	6	35	155.5	600	③
			Axis-FP 1000-6D/4-6/41/AL	4	960	6	41	159.5	600	④
			Axis-FP 1000-6D/5.5-6/48/AL	5.5	960	6	48	172.5	600	⑤

Standard size: 1000
 Number of poles: 4
 Fire resistance rating: 300/2

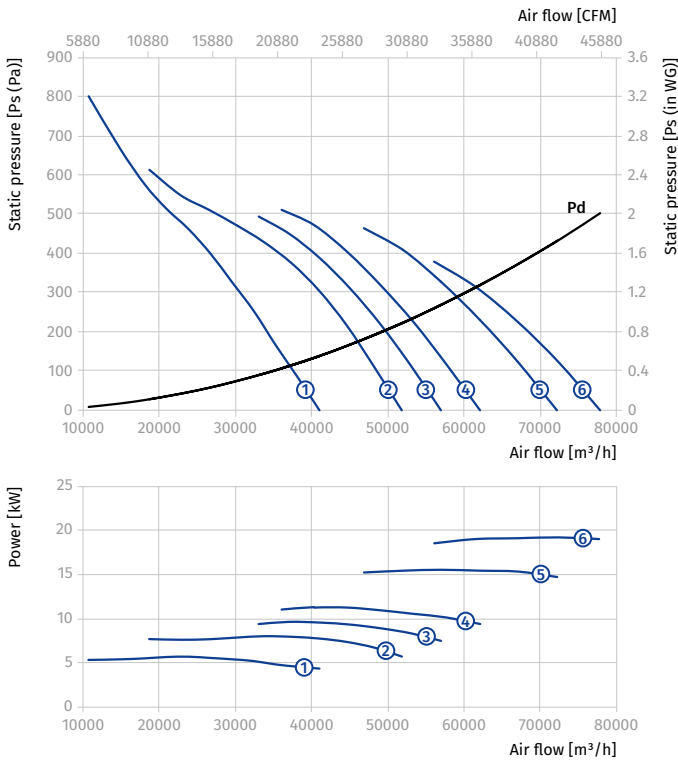

Standard size: 1000
 Number of poles: 6
 Fire resistance rating: 300/2

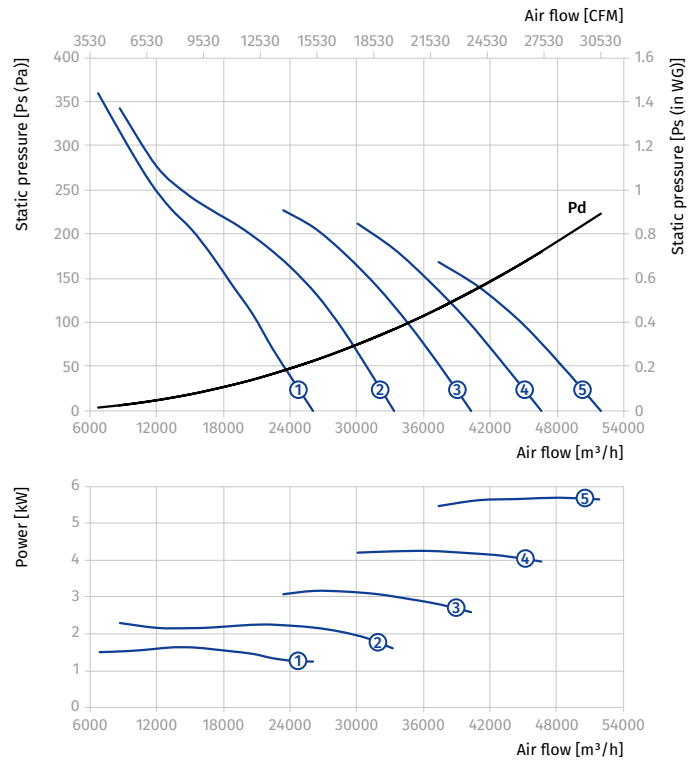

AXIS-FP 1000...300/2

Size	Number of poles	Voltage [V/50 Hz]	Fan model	Installed motor power Ny [kW]	RPM [min ⁻¹]	Number of blades	Blade setting angle [°]	Weight [kg]	Length L [mm]	Curve number on graph
Axis-FP 1000-4/6D...300/2										
1000	4/6	3~400	Axis-FP 1000-4/6D/4.5/1.5-6/20/AL	4.5/1.5	1440/960	6	20	168.5	600	①
			Axis-FP 1000-4/6D/6/2.2-6/25/AL	6/2.2	1440/960	6	25	179.5	600	②
			Axis-FP 1000-4/6D/10/3.3-6/34/AL	10/3.3	1440/960	6	34	244.5	750	③
			Axis-FP 1000-4/6D/14/4.5-6/41/AL	14/4.5	1440/960	6	41	259.5	750	④
			Axis-FP 1000-4/6D/16/6.5-6/45/AL	16/6.5	1440/960	6	45	328	800	⑤

Standard size: 1000
Number of poles: 4
Fire resistance rating: 300/2

Standard size: 1000
Number of poles: 6
Fire resistance rating: 300/2

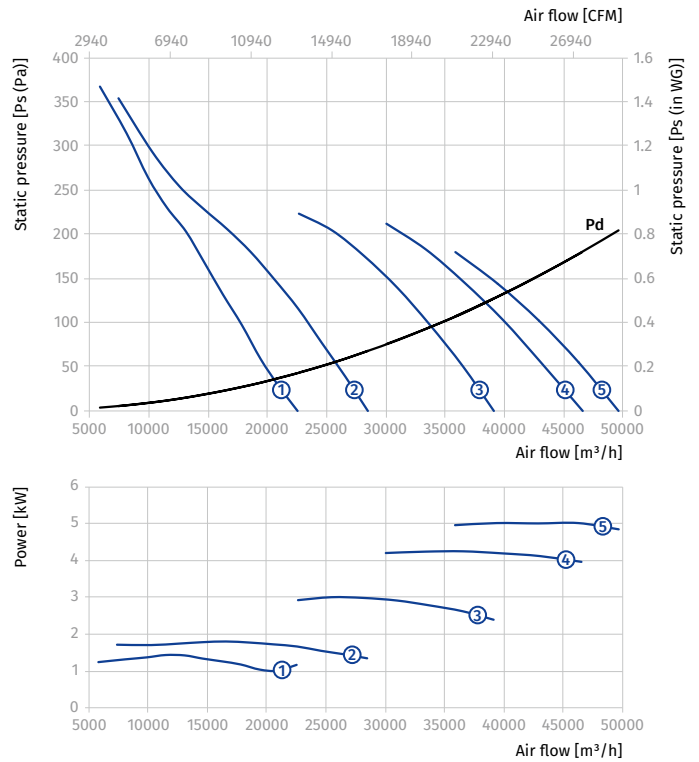
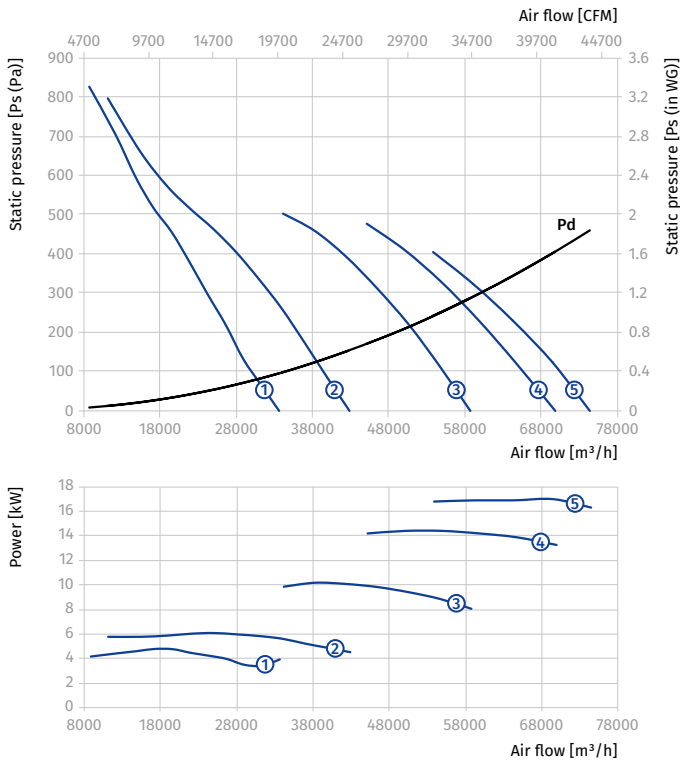

AXIS-FP 1000...300/2

Size	Number of poles	Voltage [V/50 Hz]	Fan model	Installed motor power N_y [kW]	RPM [min^{-1}]	Number of blades	Blade setting angle [°]	Weight [kg]	Length L [mm]	Curve number on graph
Axis-FP 1000-4/8D...300/2										
1000	4/8	3~400	Axis-FP 1000-4/8D/5/1.3-6/23/AL	5/1.3	1440/720	6	23	168.5	600	①
			Axis-FP 1000-4/8D/7.2/1.8-6/29/AL	7.2/1.8	1440/720	6	29	180.5	600	②
			Axis-FP 1000-4/8D/11/3-6/36/AL	11/3	1440/720	6	36	243.5	750	③
			Axis-FP 1000-4/8D/14/3.5-6/41/AL	14/3.5	1440/720	6	41	259.5	750	④
			Axis-FP 1000-4/8D/17/4.3-6/46/AL	17/4.3	1440/720	6	46	295	800	⑤

Standard size: 1000
 Number of poles: 4
 Fire resistance rating: 300/2

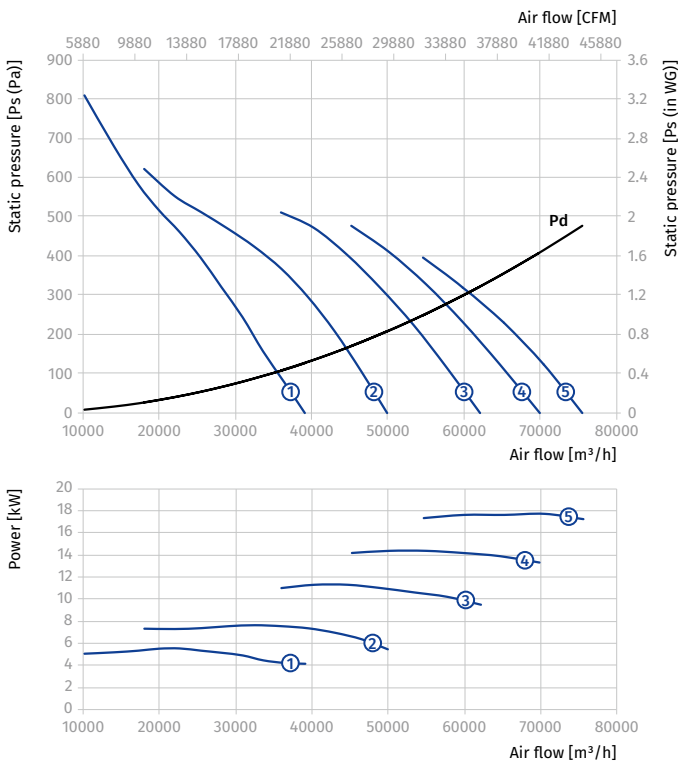

Standard size: 1000
 Number of poles: 8
 Fire resistance rating: 300/2

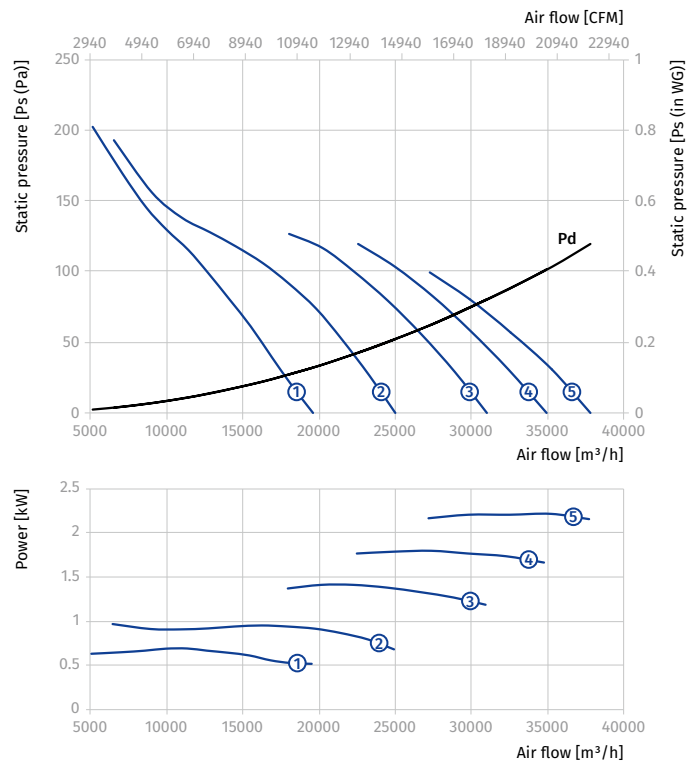

AXIS-FP 1120...300/2

Size	Number of poles	Voltage [V/50 Hz]	Fan model	Installed motor power Ny [kW]	RPM [min ⁻¹]	Number of blades	Blade setting angle [°]	Weight [kg]	Length L [mm]	Curve number on graph
Axis-FP 1120-4D...300/2										
1120	4	3~400	Axis-FP 1120-4D/7.5-6/23/AL	7.5	1440	6	23	183	600	①
			Axis-FP 1120-4D/9.2-6/27/AL	9.2	1440	6	27	189	600	②
			Axis-FP 1120-4D/11-6/31/AL	11	1440	6	31	202	600	③
			Axis-FP 1120-4D/15-6/35/AL	15	1440	6	35	296	750	④
			Axis-FP 1120-4D/18.5-6/40/AL	18.5	1440	6	40	312	750	⑤
			Axis-FP 1120-4D/22-6/43/AL	22	1440	6	43	352	800	⑥
Axis-FP 1120-6D...300/2										
1120	6	3~400	Axis-FP 1120-6D/2.2-6/23/AL	2.2	960	6	23	146	550	①
			Axis-FP 1120-6D/3-6/29/AL	3	960	6	29	174	600	②
			Axis-FP 1120-6D/4-6/34/AL	4	960	6	34	178	600	③
			Axis-FP 1120-6D/5.5-6/40/AL	5.5	960	6	40	191	600	④
			Axis-FP 1120-6D/7.5-6/46/AL	7.5	960	6	46	280	750	⑤
			Axis-FP 1120-6D/9.2-6/50/AL	9.2	960	6	50	289	750	⑥

Standard size: 1120
Number of poles: 4
Fire resistance rating: 300/2

Standard size: 1120
Number of poles: 6
Fire resistance rating: 300/2

AXIAL SMOKE EXTRACTION FANS

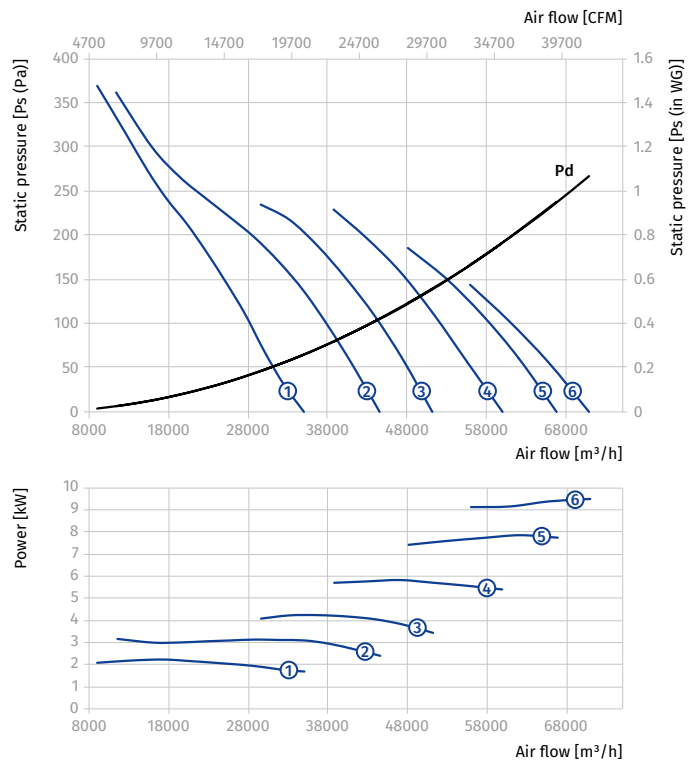
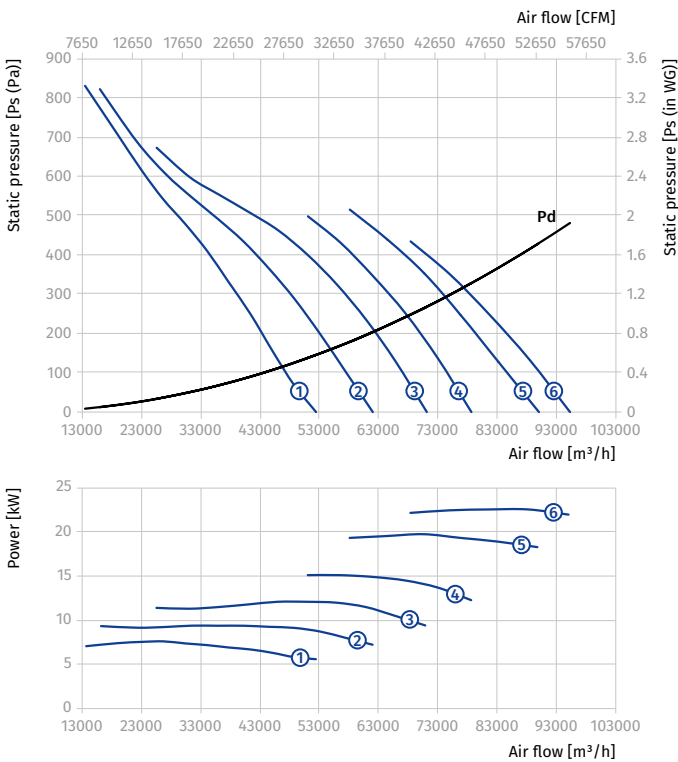

AXIS-FP 1120...300/2

Size	Number of poles	Voltage [V/50 Hz]	Fan model	Installed motor power N_y [kW]	RPM [min^{-1}]	Number of blades	Blade setting angle [°]	Weight [kg]	Length L [mm]	Curve number on graph
Axis-FP 1120-4/6D...300/2										
1120	4/6	3~400	Axis-FP 1120-4/6D/6/2.2-5/24/AL	6/2.2	1440/960	5	24	196	600	①
			Axis-FP 1120-4/6D/10/3.3-6/29/AL	10/3.3	1440/960	6	29	297	750	②
			Axis-FP 1120-4/6D/14/4.5-6/34/AL	14/4.5	1440/960	6	34	312	750	③
			Axis-FP 1120-4/6D/16/6.5-6/37/AL	16/6.5	1440/960	6	37	384	800	④
			Axis-FP 1120-4/6D/20/8.5-6/41/AL	20/8.5	1440/960	6	41	387	800	⑤

Standard size: 1120
 Number of poles: 4
 Fire resistance rating: 300/2

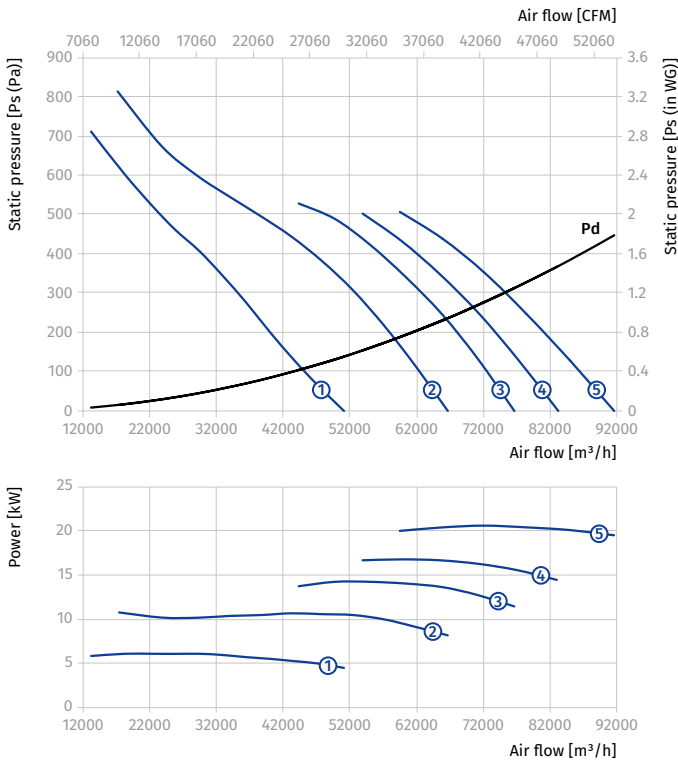

Standard size: 1120
 Number of poles: 6
 Fire resistance rating: 300/2

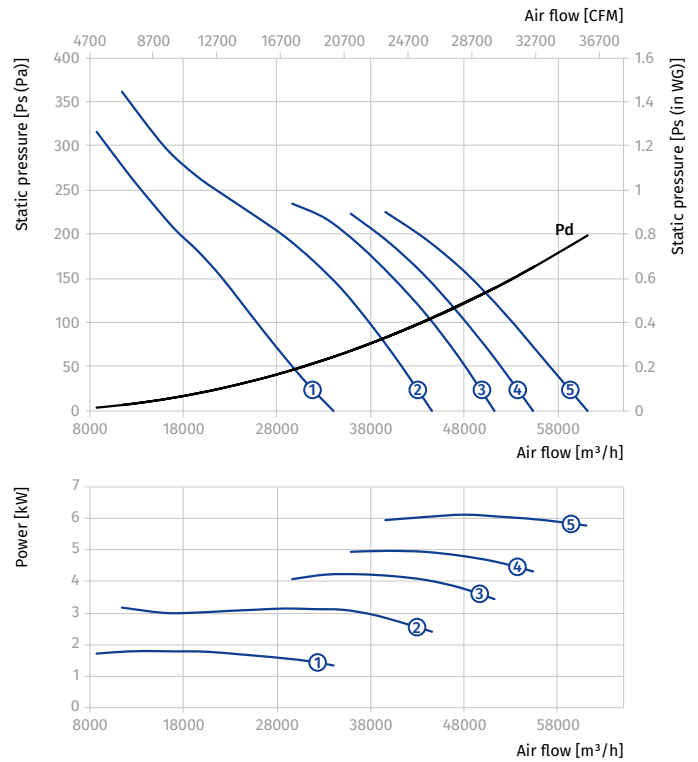

AXIS-FP 1120...300/2

Size	Number of poles	Voltage [V/50 Hz]	Fan model	Installed motor power Ny [kW]	RPM [min ⁻¹]	Number of blades	Blade setting angle [°]	Weight [kg]	Length L [mm]	Curve number on graph
Axis-FP 1120-4/8D...300/2										
1120	4/8	3~400	Axis-FP 1120-4/8D/7.2/1.8-6/23/AL	7.2/1.8	1440/720	6	23	199	600	①
			Axis-FP 1120-4/8D/11/3-6/31/AL	11/3	1440/720	6	31	296	750	②
			Axis-FP 1120-4/8D/14/3.5-6/34/AL	14/3.5	1440/720	6	34	312	750	③
			Axis-FP 1120-4/8D/17/4.3-6/38/AL	17/4.3	1440/720	6	38	351	800	④
			Axis-FP 1120-4/8D/20/5-6/41/AL	20/5	1440/720	6	41	379	800	⑤

Standard size: 1120
Number of poles: 4
Fire resistance rating: 300/2

Standard size: 1120
Number of poles: 8
Fire resistance rating: 300/2

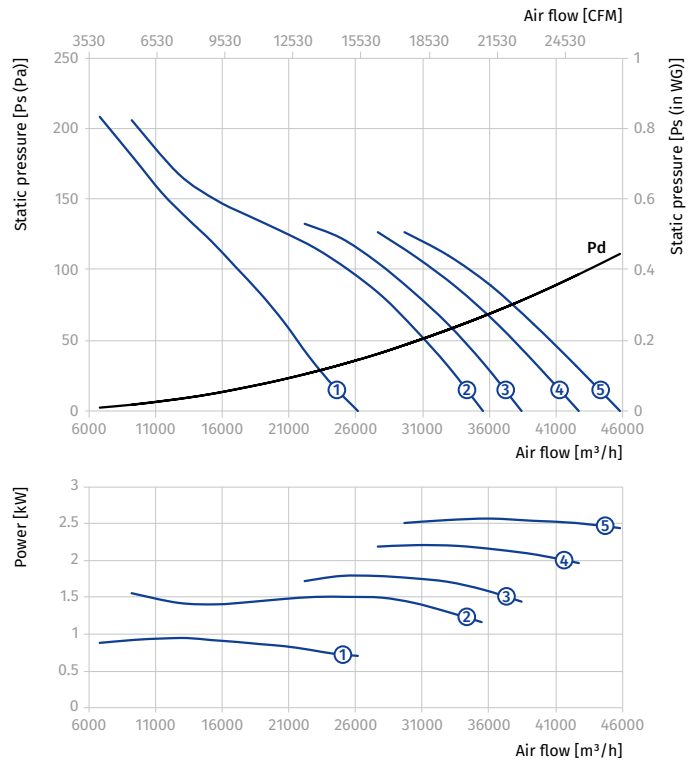
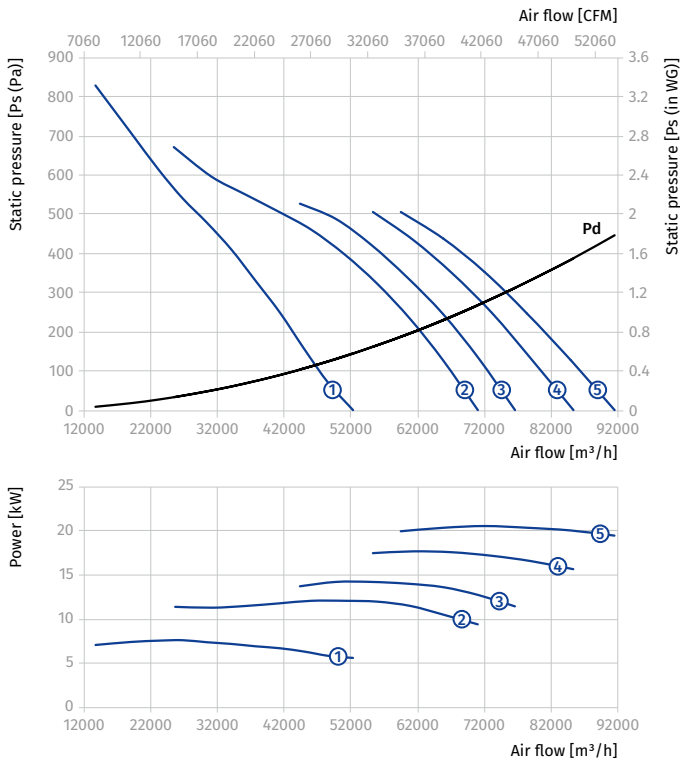

AXIS-FP 1250...300/2

Size	Number of poles	Voltage [V/50 Hz]	Fan model	Installed motor power N_y [kW]	RPM [min^{-1}]	Number of blades	Blade setting angle [°]	Weight [kg]	Length L [mm]	Curve number on graph
Axis-FP 1250-4D...300/2										
1250	4	3~400	Axis-FP 1250-4D/18.5-8/23/AL	18.5	1440	8	23	335	750	①
			Axis-FP 1250-4D/22-8/28/AL	22	1440	8	28	377.5	800	②
			Axis-FP 1250-4D/30-8/34/AL	30	1440	8	34	403.5	800	③
Axis-FP 1250-6D...300/2										
1250	6	3~400	Axis-FP 1250-6D/5.5-8/23/AL	5.5	960	8	23	231	600	①
			Axis-FP 1250-6D/7.5-8/30/AL	7.5	960	8	30	303	750	②
			Axis-FP 1250-6D/9.2-8/34/AL	9.2	960	8	34	303	750	③
			Axis-FP 1250-6D/11-8/38/AL	11	960	8	38	327	750	④

Standard size: 1250
 Number of poles: 4
 Fire resistance rating: 300/2

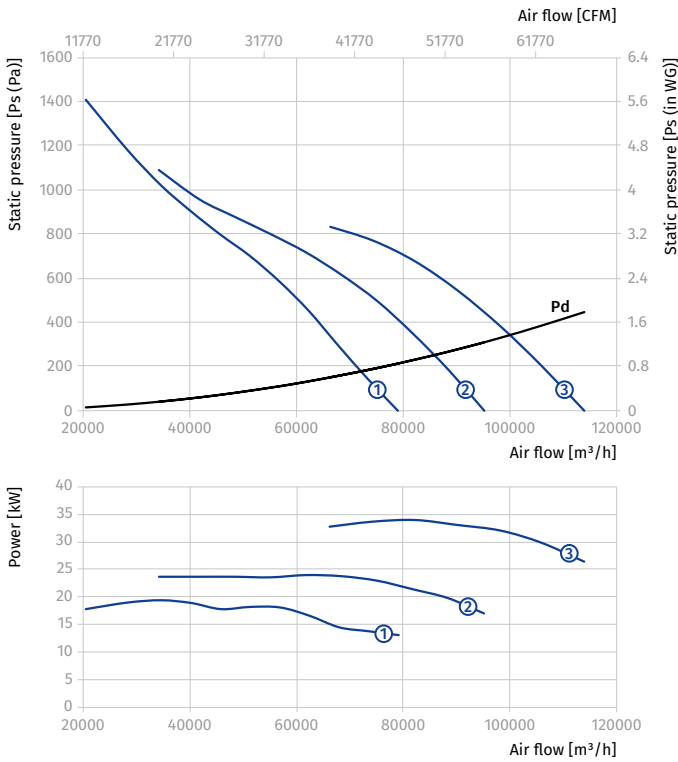

Standard size: 1250
 Number of poles: 6
 Fire resistance rating: 300/2

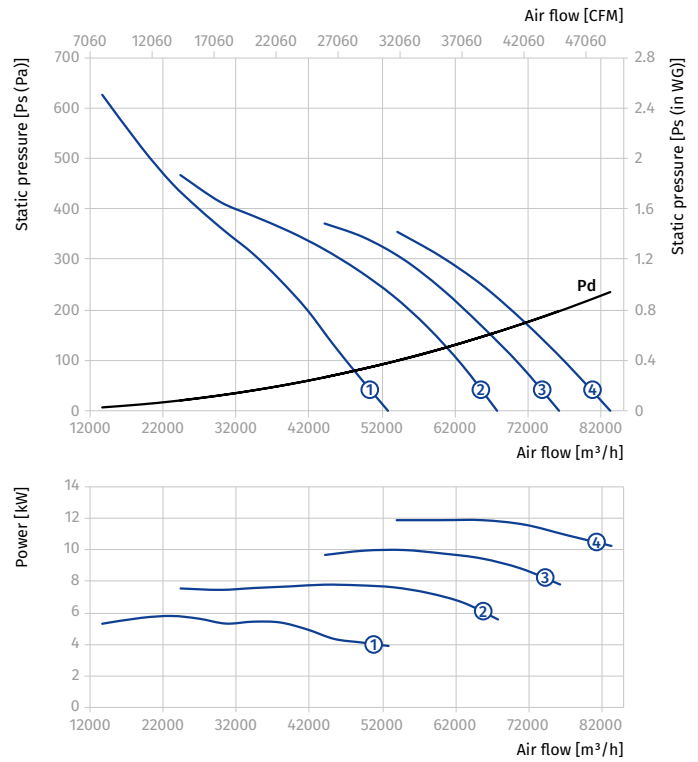

AXIS-FP 1250...300/2

Size	Number of poles	Voltage [V/50 Hz]	Fan model	Installed motor power Ny [kW]	RPM [min ⁻¹]	Number of blades	Blade setting angle [°]	Weight [kg]	Length L [mm]	Curve number on graph
Axis-FP 1250-4/6D...300/2										
1250	4/6	3~400	Axis-FP 1250-4/6D/16/6.5-8/20/AL	16/6.5	1440/960	8	20	408.5	800	①
			Axis-FP 1250-4/6D/20/8.5-8/25/AL	20/8.5	1440/960	8	25	411.5	800	②
			Axis-FP 1250-4/6D/26/9-8/31/AL	26/9	1440/960	8	31	510	850	③

Standard size: 1250
Number of poles: 4
Fire resistance rating: 300/2

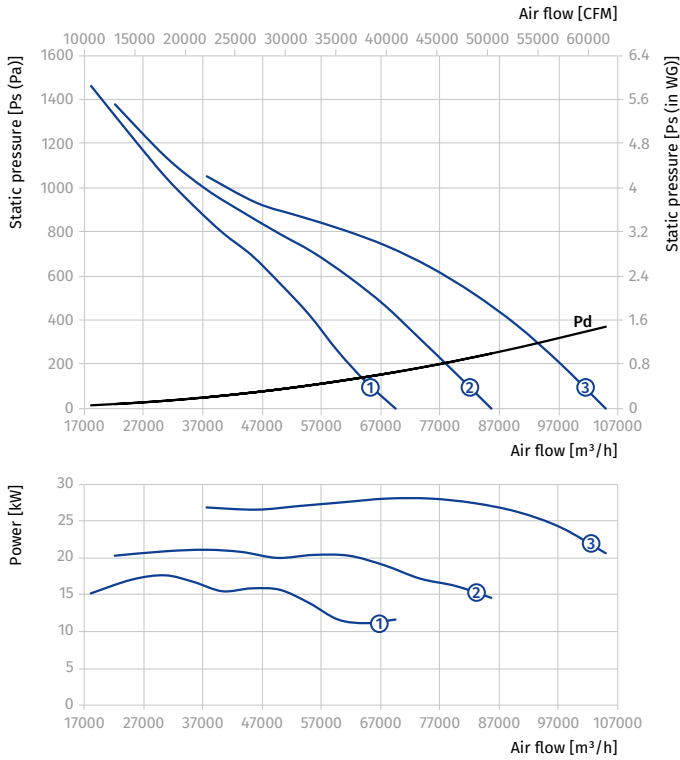

Standard size: 1250
Number of poles: 6
Fire resistance rating: 300/2

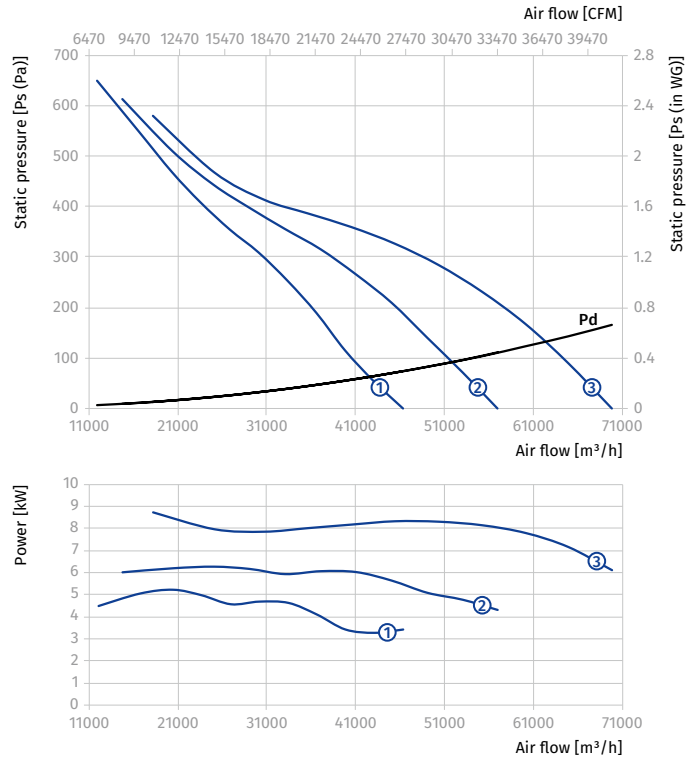

AXIS-FP 1250...300/2

Size	Number of poles	Voltage [V/50 Hz]	Fan model	Installed motor power N_y [kW]	RPM [min^{-1}]	Number of blades	Blade setting angle [°]	Weight [kg]	Length L [mm]	Curve number on graph
Axis-FP 1250-4/8D...300/2										
1250	4/8	3~400	Axis-FP 1250-4/8D/17/4.3-8/21/AL	17/4.3	1440/720	8	21	375.5	800	①
			Axis-FP 1250-4/8D/20/5-8/25/AL	20/5	1440/720	8	25	403.5	800	②
			Axis-FP 1250-4/8D/28/6.5-8/32/AL	28/6.5	1440/720	8	32	465	850	③

Standard size: 1250
 Number of poles: 4
 Fire resistance rating: 300/2

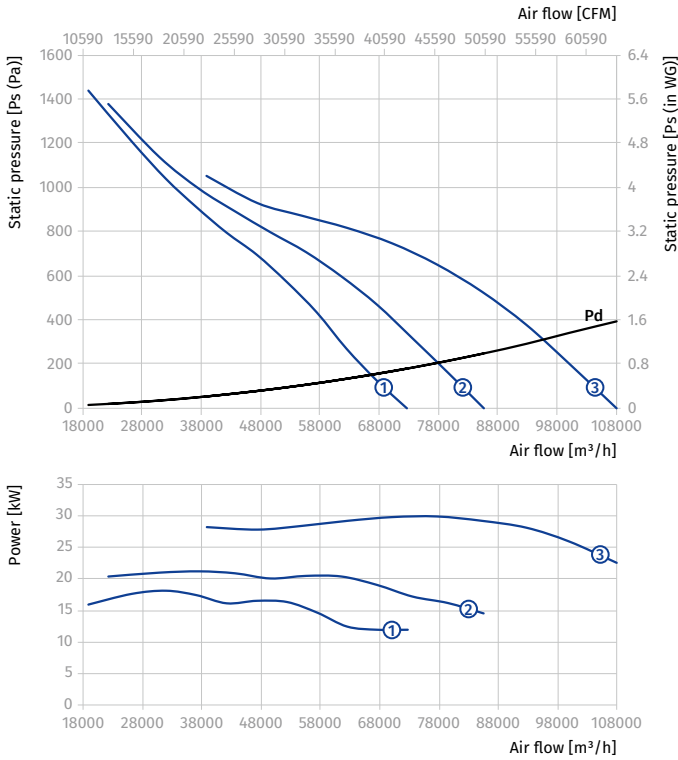

Standard size: 1250
 Number of poles: 8
 Fire resistance rating: 300/2

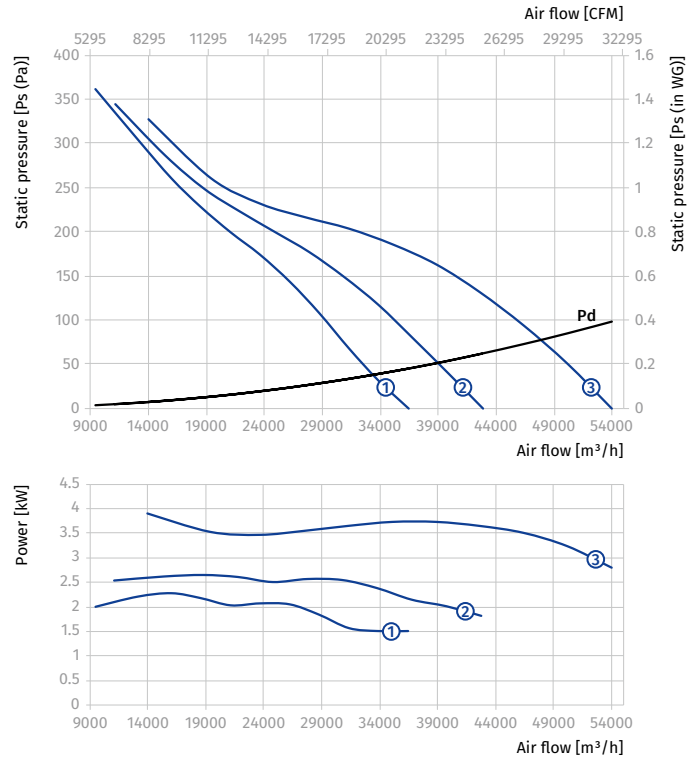

Technical data AXIS-FP...400/2

AXIS-FP 400...400/2

Size	Number of poles	Voltage [V/50 Hz]	Fan model	Installed motor power Ny [kW]	RPM [min ⁻¹]	Number of blades	Blade setting angle [°]	Weight [kg]	Length L [mm]	Curve number on graph
Axis-FP 400-2D...400/2										
400	2	3~400	Axis-FP 400-2D/0.75-4/25/AL	0.75	2880	4	25	25.6	400	①
			Axis-FP 400-2D/1.1-4/35/AL	1.1	2880	4	35	29.7	400	②
			Axis-FP 400-2D/1.5-4/40/AL	1.5	2880	4	40	31.2	400	③
			Axis-FP 400-2D/2.2-6/40/AL	2.2	2880	6	40	33.8	400	④
			Axis-FP 400-2D/2.2-6/45/AL	2.2	2880	6	45	33.8	400	⑤
Axis-FP 400-4D...400/2										
400	4	3~400	Axis-FP 400-4D/0.55-6/30/AL	0.55	1440	6	30	26.1	400	①
			Axis-FP 400-4D/0.55-6/35/AL	0.55	1440	6	35	26.1	400	②
			Axis-FP 400-4D/0.55-6/40/AL	0.55	1440	6	40	25.3	400	③
			Axis-FP 400-4D/0.55-9/40/AL	0.55	1440	9	40	26.5	400	④
			Axis-FP 400-4D/0.55-12/40/AL	0.55	1440	12	40	27.0	400	⑤
			Axis-FP 400-4D/0.55-12/45/AL	0.55	1440	12	45	27.0	400	⑥

Standard size: 400
Number of poles: 2
Fire resistance rating: 400/2

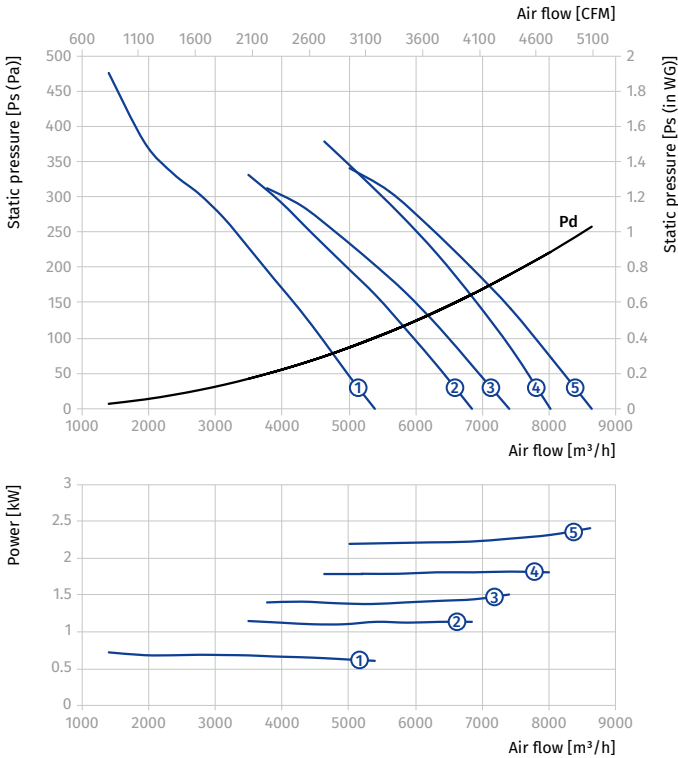

Standard size: 400
Number of poles: 4
Fire resistance rating: 400/2

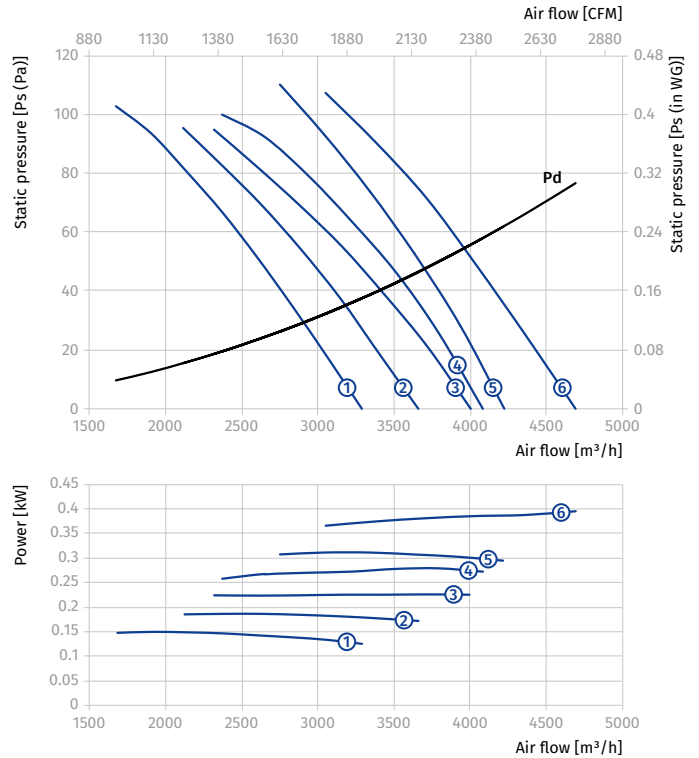

AXIS-FP 400...400/2

Size	Number of poles	Voltage [V/50 Hz]	Fan model	Installed motor power N_y [kW]	RPM [min^{-1}]	Number of blades	Blade setting angle [°]	Weight [kg]	Length L [mm]	Curve number on graph
Axis-FP 400-2/4D...400/2										
400	2/4	3~400	Axis-FP 400-2/4D/0.8/0.2-4/25/AL	0.8/0.2	2880/1440	4	25	30.3	400	①
			Axis-FP 400-2/4D/1.1/0.25-4/35/AL	1.1/0.25	2880/1440	4	35	31.3	400	②
			Axis-FP 400-2/4D/1.5/0.37-4/40/AL	1.5/0.37	2880/1440	4	40	36.8	400	③
			Axis-FP 400-2/4D/2.2/0.5-6/40/AL	2.2/0.5	2880/1440	6	40	39.1	400	④
			Axis-FP 400-2/4D/2.2/0.5-6/45/AL	2.2/0.5	2880/1440	6	45	39.1	400	⑤

Standard size: 400
 Number of poles: 2
 Fire resistance rating: 400/2

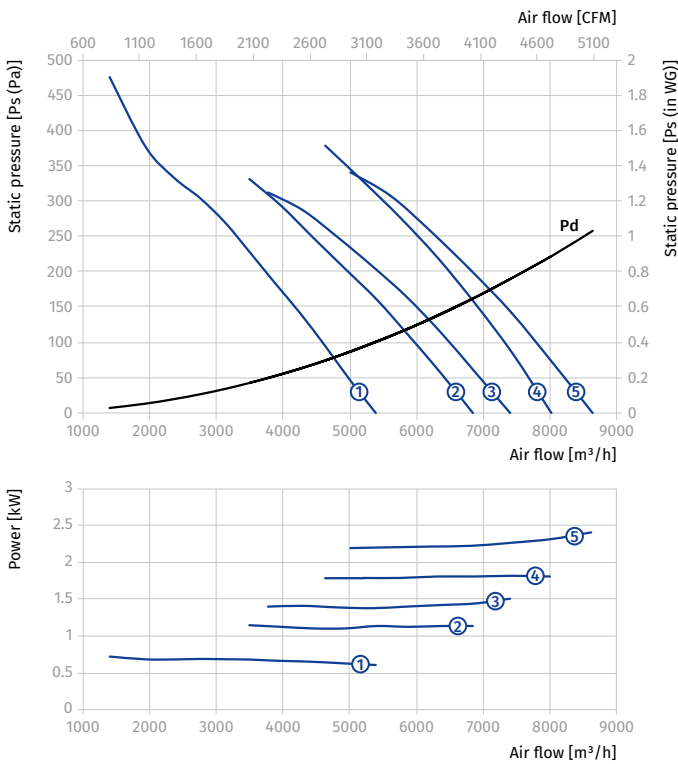

Standard size: 400
 Number of poles: 4
 Fire resistance rating: 400/2

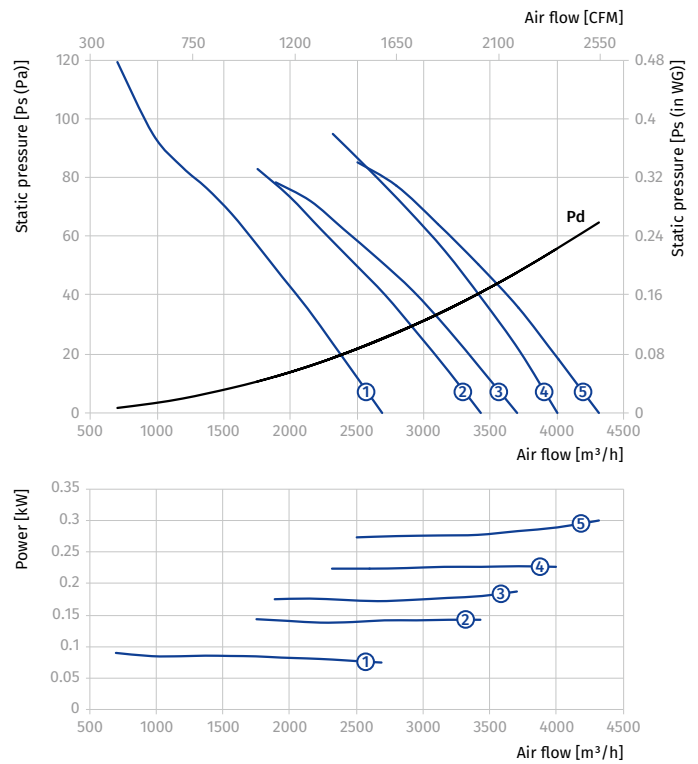

AXIS-FP 450...400/2

Size	Number of poles	Voltage [V/50 Hz]	Fan model	Installed motor power Ny [kW]	RPM [min ⁻¹]	Number of blades	Blade setting angle [°]	Weight [kg]	Length L [mm]	Curve number on graph
Axis-FP 450-2D...400/2										
450	2	3~400	Axis-FP 450-2D/0.75-4/20/AL	0.75	2880	4	20	27.3	400	①
			Axis-FP 450-2D/1.1-4/25/AL	1.1	2880	4	25	31.3	400	②
			Axis-FP 450-2D/1.5-4/30/AL	1.5	2880	4	30	32.8	400	③
			Axis-FP 450-2D/2.2-6/35/AL	2.2	2880	6	35	35.4	400	④
			Axis-FP 450-2D/3-12/35/AL	3	2880	12	35	43.3	400	⑤
			Axis-FP 450-2D/4-12/40/AL	4	2880	12	40	55.2	500	⑥
Axis-FP 450-4D...400/2										
450	4	3~400	Axis-FP 450-4D/0.55-6/25/AL	0.55	1440	6	25	27.6	400	①
			Axis-FP 450-4D/0.55-6/30/AL	0.55	1440	6	30	27.6	400	②
			Axis-FP 450-4D/0.55-6/35/AL	0.55	1440	6	35	27.6	400	③
			Axis-FP 450-4D/0.55-6/40/AL	0.55	1440	6	40	27.6	400	④
			Axis-FP 450-4D/0.55-9/40/AL	0.55	1440	9	40	28.2	400	⑤
			Axis-FP 450-4D/0.55-9/45/AL	0.55	1440	9	45	28.2	400	⑥

Standard size: 450
Number of poles: 2
Fire resistance rating: 400/2

Standard size: 450
Number of poles: 4
Fire resistance rating: 400/2

AXIAL SMOKE EXTRACTION FANS

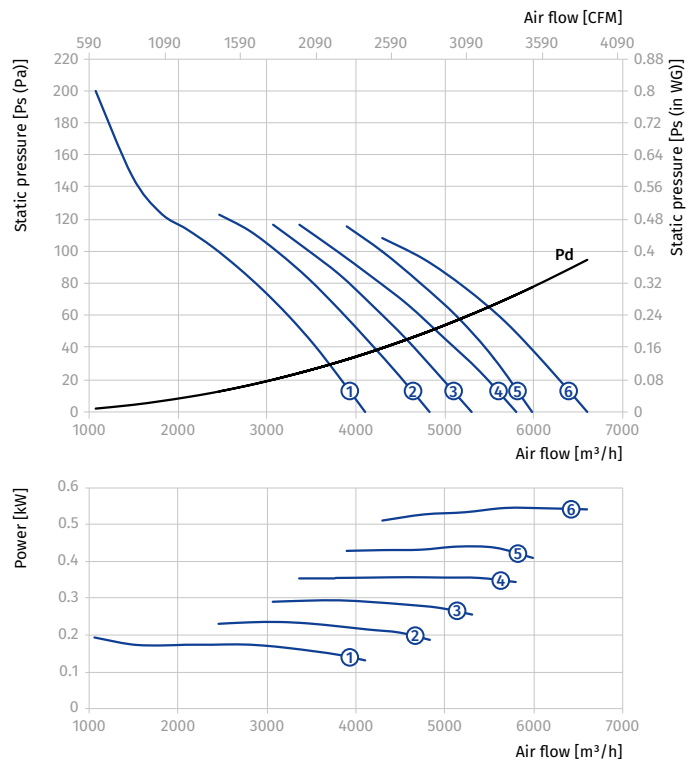
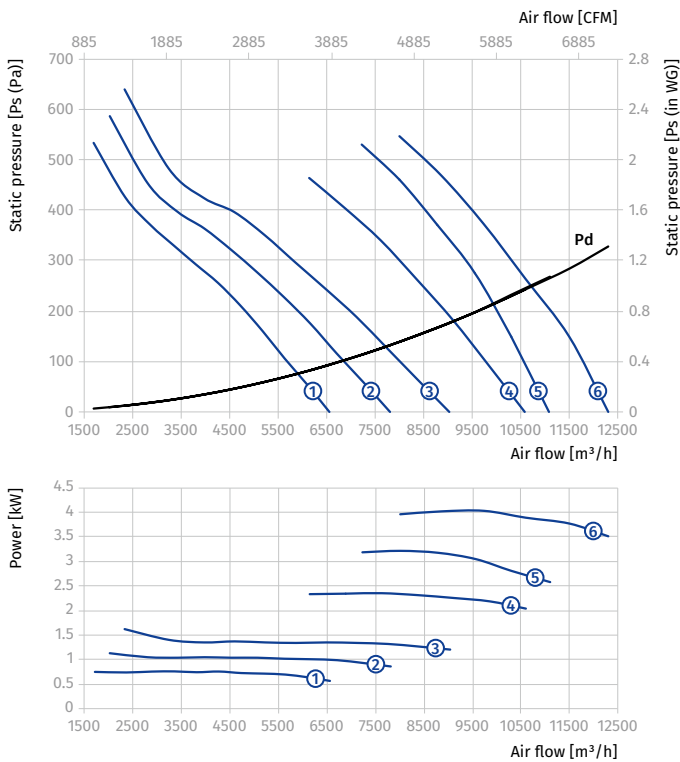

AXIS-FP 450...400/2

Size	Number of poles	Voltage [V/50 Hz]	Fan model	Installed motor power N_y [kW]	RPM [min^{-1}]	Number of blades	Blade setting angle [°]	Weight [kg]	Length L [mm]	Curve number on graph
Axis-FP 450-2/4D...400/2										
450	2/4	3~400	Axis-FP 450-2/4D/0.8/0.2-4/20/AL	0.8/0.2	2880/1440	4	20	31.8	400	①
			Axis-FP 450-2/4D/1.1/0.25-4/25/AL	1.1/0.25	2880/1440	4	25	32.8	400	②
			Axis-FP 450-2/4D/1.5/0.37-4/30/AL	1.5/0.37	2880/1440	4	30	38.3	400	③
			Axis-FP 450-2/4D/2.2/0.5-6/35/AL	2.2/0.5	2880/1440	6	35	40.7	400	④
			Axis-FP 450-2/4D/3.1/0.8-12/35/AL	3.1/0.8	2880/1440	12	35	54.2	500	⑤
			Axis-FP 450-2/4D/4.4/1.1-12/40/AL	4.4/1.1	2880/1440	12	40	66.2	500	⑥

Standard size: 450
 Number of poles: 2
 Fire resistance rating: 400/2

Standard size: 450
 Number of poles: 4
 Fire resistance rating: 400/2

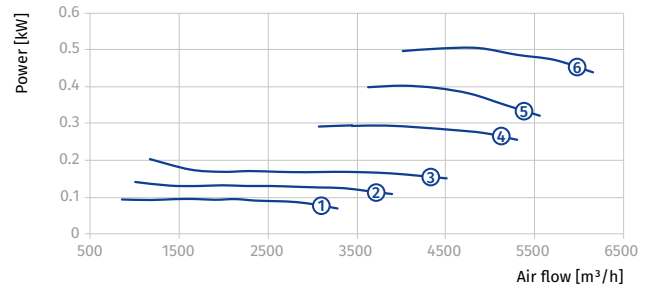
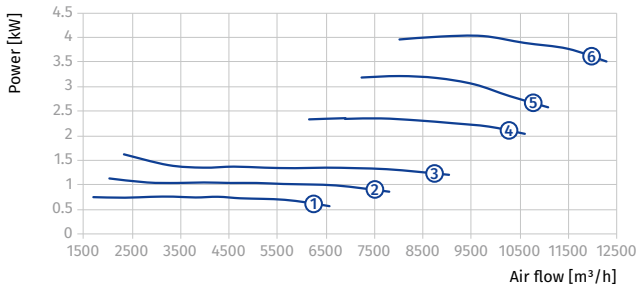
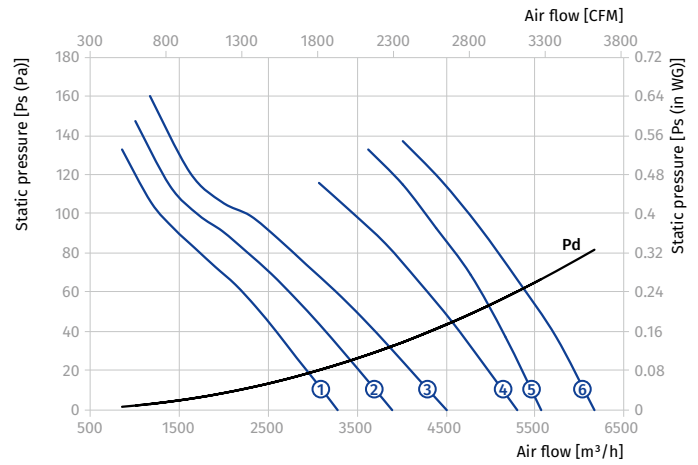
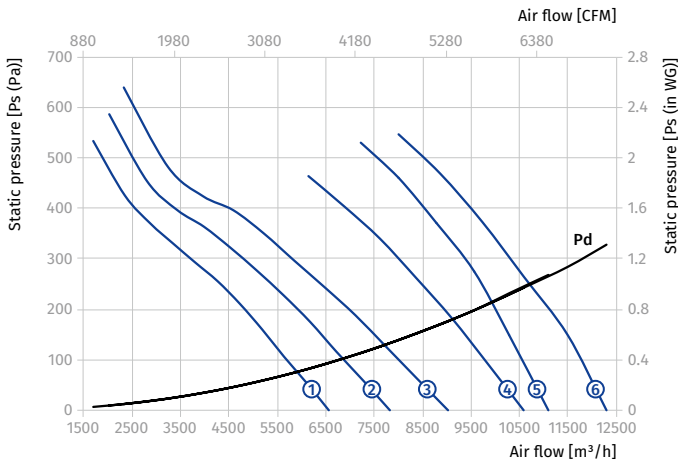

AXIS-FP 500...400/2

Size	Number of poles	Voltage [V/50 Hz]	Fan model	Installed motor power Ny [kW]	RPM [min ⁻¹]	Number of blades	Blade setting angle [°]	Weight [kg]	Length L [mm]	Curve number on graph
Axis-FP 500-2D...400/2										
500	2	3~400	Axis-FP 500-2D/1.5-6/20/AL	1.5	2880	6	20	35.0	400	①
			Axis-FP 500-2D/2.2-6/25/AL	2.2	2880	6	25	37.5	400	②
			Axis-FP 500-2D/3-6/30/AL	3	2880	6	30	44.0	400	③
			Axis-FP 500-2D/4-6/35/AL	4	2880	6	35	56.5	500	④
			Axis-FP 500-2D/5.5-9/40/AL	5.5	2880	9	40	65.0	500	⑤
Axis-FP 500-4D...400/2										
500	4	3~400	Axis-FP 500-4D/0.55-6/20/AL	0.55	1440	6	20	29.5	400	①
			Axis-FP 500-4D/0.55-6/25/AL	0.55	1440	6	25	29.5	400	②
			Axis-FP 500-4D/0.55-6/30/AL	0.55	1440	6	30	29.5	400	③
			Axis-FP 500-4D/0.55-6/35/AL	0.55	1440	6	35	29.5	400	④
			Axis-FP 500-4D/0.55-6/40/AL	0.55	1440	6	40	29.5	400	⑤
			Axis-FP 500-4D/0.75-9/40/AL	0.75	1440	9	40	31.0	400	⑥

Standard size: 500
Number of poles: 2
Fire resistance rating: 400/2

Standard size: 500
Number of poles: 4
Fire resistance rating: 400/2

AXIAL SMOKE EXTRACTION FANS

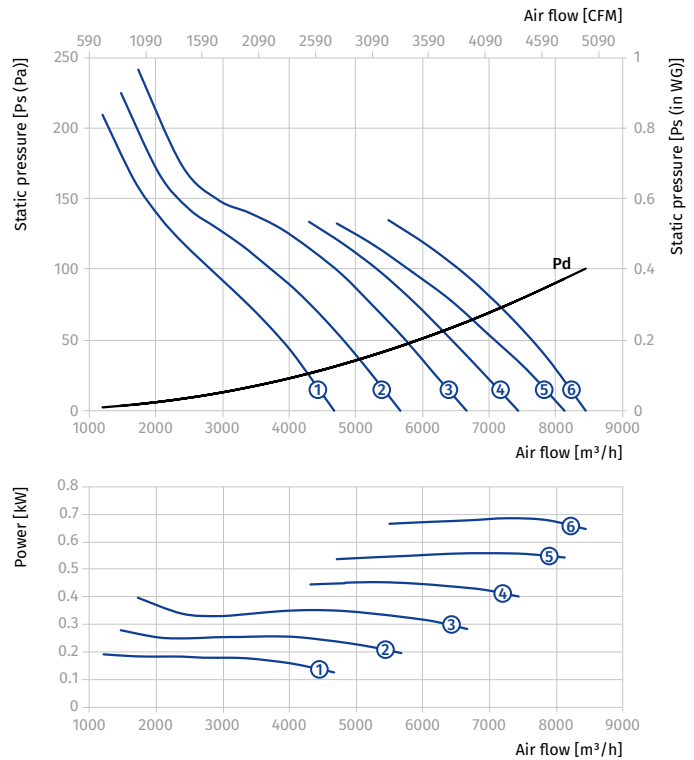
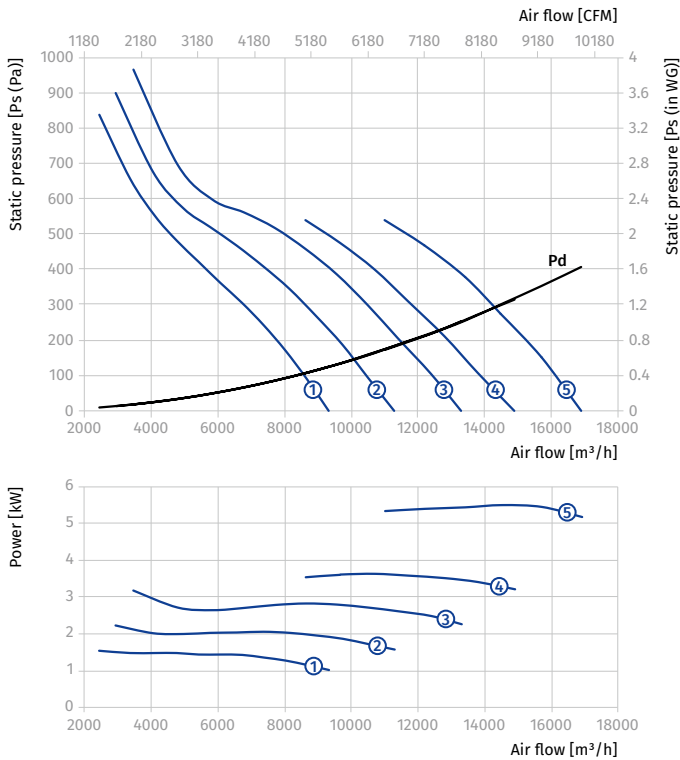

AXIS-FP 500...400/2

Size	Number of poles	Voltage [V/50 Hz]	Fan model	Installed motor power N_y [kW]	RPM [min^{-1}]	Number of blades	Blade setting angle [°]	Weight [kg]	Length L [mm]	Curve number on graph
Axis-FP 500-2/4D...400/2										
500	2/4	3~400	Axis-FP 500-2/4D/1.5/0.37-6/20/AL	1.5/0.37	2880/1440	6	20	40.5	400	①
			Axis-FP 500-2/4D/2.2/0.5-6/25/AL	2.2/0.5	2880/1440	6	25	42.5	400	②
			Axis-FP 500-2/4D/3.1/0.8-6/30/AL	3.1/0.8	2880/1440	6	30	55.5	500	③
			Axis-FP 500-2/4D/4.4/1.1-6/35/AL	4.4/1.1	2880/1440	6	35	67.5	500	④
			Axis-FP 500-2/4D/6.0/1.5-9/40/AL	6.0/1.5	2880/1440	9	40	87	550	⑤

Standard size: 500
 Number of poles: 2
 Fire resistance rating: 400/2

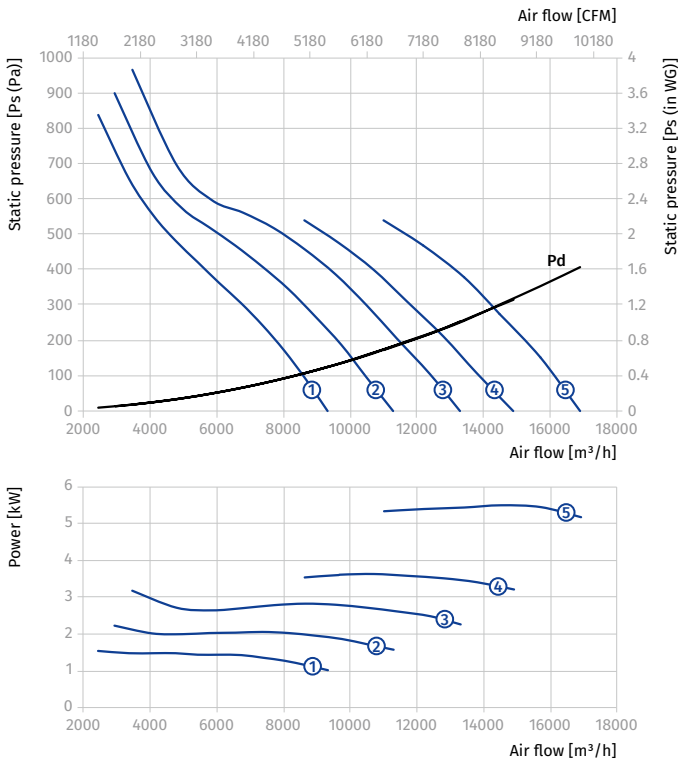

Standard size: 500
 Number of poles: 4
 Fire resistance rating: 400/2

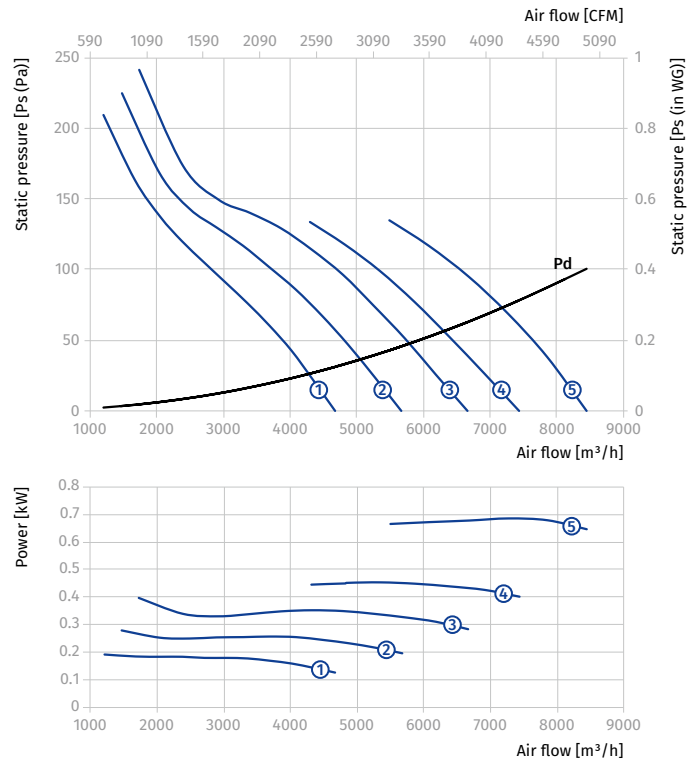

AXIS-FP 560...400/2

Size	Number of poles	Voltage [V/50 Hz]	Fan model	Installed motor power Ny [kW]	RPM [min ⁻¹]	Number of blades	Blade setting angle [°]	Weight [kg]	Length L [mm]	Curve number on graph
Axis-FP 560-2D...400/2										
560	2	3~400	Axis-FP 560-2D/2.2-6/20/AL	2.2	2880	6	20	39.5	400	①
			Axis-FP 560-2D/3-6/25/AL	3	2880	6	25	46	400	②
			Axis-FP 560-2D/4-6/30/AL	4	2880	6	30	58.5	500	③
			Axis-FP 560-2D/5.5-6/35/AL	5.5	2880	6	35	66.5	500	④
			Axis-FP 560-2D/7.5-12/35/AL	7.5	2880	12	35	70	500	⑤
Axis-FP 560-4D...400/2										
560	4	3~400	Axis-FP 560-4D/0.55-6/20/AL	0.55	1440	6	20	31.5	400	①
			Axis-FP 560-4D/0.55-6/25/AL	0.55	1440	6	25	31.5	400	②
			Axis-FP 560-4D/0.55-6/30/AL	0.55	1440	6	30	31.5	400	③
			Axis-FP 560-4D/0.75-6/35/AL	0.75	1440	6	35	32.5	400	④
			Axis-FP 560-4D/1.1-9/40/AL	1.1	1440	9	40	37.5	400	⑤
			Axis-FP 560-4D/1.5-12/45/AL	1.5	1440	12	45	41	400	⑥

Standard size: 560
Number of poles: 2
Fire resistance rating: 400/2

Standard size: 560
Number of poles: 4
Fire resistance rating: 400/2

AXIAL SMOKE EXTRACTION FANS

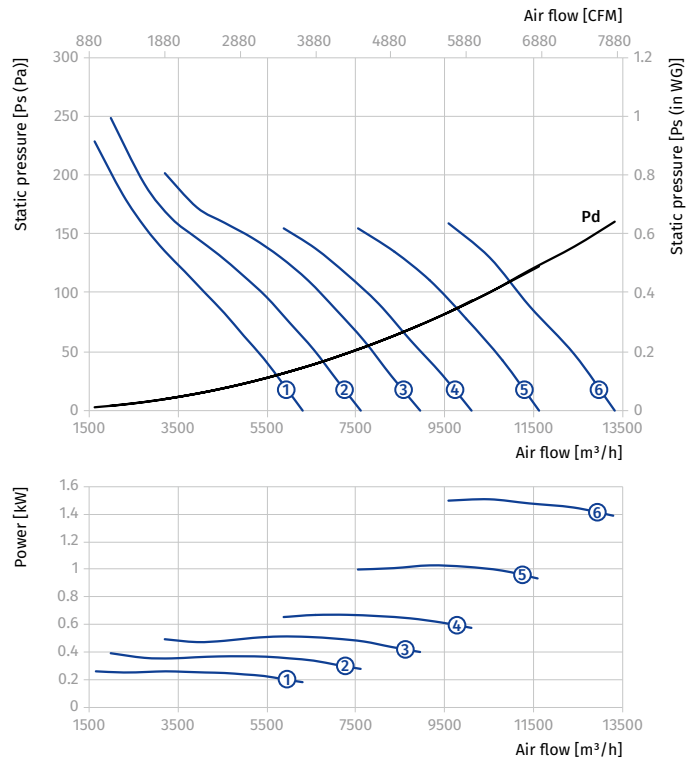
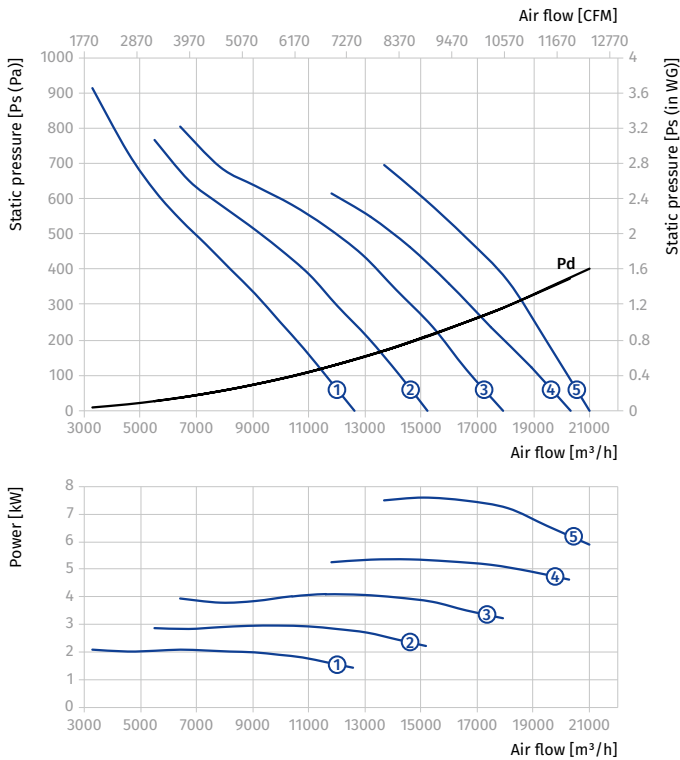

AXIS-FP 560...400/2

Size	Number of poles	Voltage [V/50 Hz]	Fan model	Installed motor power N_y [kW]	RPM [min ⁻¹]	Number of blades	Blade setting angle [°]	Weight [kg]	Length L [mm]	Curve number on graph
Axis-FP 560-2/4D...400/2										
560	2/4	3~400	Axis-FP 560-2/4D/2.2/0.5-6/20/AL	2.2/0.5	2880/1440	6	20	44.5	400	①
			Axis-FP 560-2/4D/3.1/0.8-6/25/AL	3.1/0.8	2880/1440	6	25	57.5	500	②
			Axis-FP 560-2/4D/4.4/1.1-6/30/AL	4.4/1.1	2880/1440	6	30	69.5	500	③
			Axis-FP 560-2/4D/6.0/1.5-6/35/AL	6.0/1.5	2880/1440	6	35	97.5	550	④
			Axis-FP 560-2/4D/8.0/2.0-12/35/AL	8.0/2.0	2880/1440	12	35	108	550	⑤

Standard size: 560
 Number of poles: 2
 Fire resistance rating: 400/2

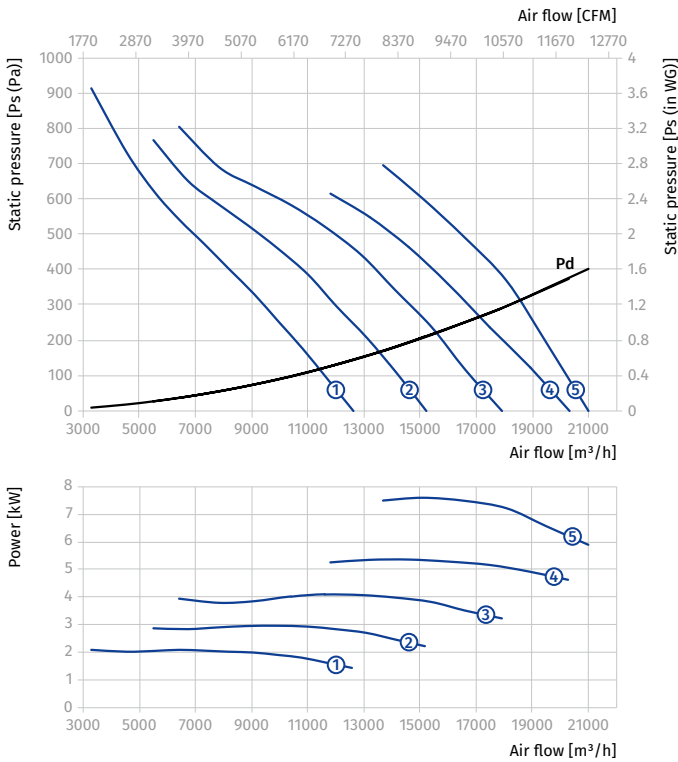

Standard size: 560
 Number of poles: 4
 Fire resistance rating: 400/2

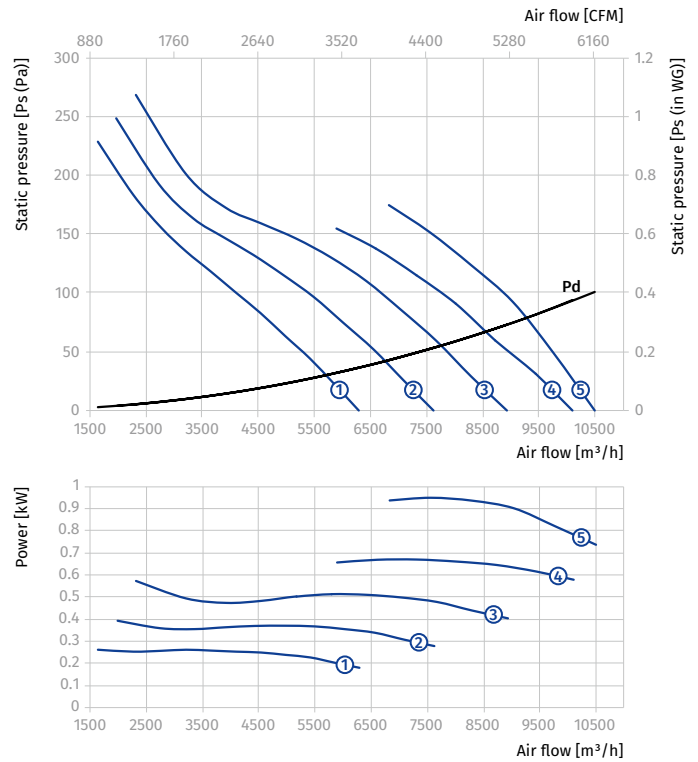

AXIAL SMOKE EXTRACTION FANS

AXIS-FP 630...400/2

Size	Number of poles	Voltage [V/50 Hz]	Fan model	Installed motor power Ny [kW]	RPM [min ⁻¹]	Number of blades	Blade setting angle [°]	Weight [kg]	Length L [mm]	Curve number on graph
Axis-FP 630-2D...400/2										
630	2	3~400	Axis-FP 630-2D/4-9/20/AL	4	2880	9	20	62	500	①
			Axis-FP 630-2D/5.5-9/25/AL	5.5	2880	9	25	70	500	②
			Axis-FP 630-2D/7.5-9/30/AL	7.5	2880	9	30	72	500	③
			Axis-FP 630-2D/11-9/35/AL	11	2880	9	35	118	550	④
			Axis-FP 630-2D/15-9/40/AL	15	2880	9	40	165.5	700	⑤
			Axis-FP 630-2D/18.5-9/45/AL	18.5	2880	9	45	179.5	700	⑥
			Axis-FP 630-2D/18.5-12/45/AL	18.5	2880	12	45	180.5	700	⑦
Axis-FP 630-4D...400/2										
630	4	3~400	Axis-FP 630-4D/0.55-9/20/AL	0.55	1440	9	20	34.5	400	①
			Axis-FP 630-4D/0.75-9/25/AL	0.75	1440	9	25	35.5	400	②
			Axis-FP 630-4D/1.1-9/30/AL	1.1	1440	9	30	39.5	400	③
			Axis-FP 630-4D/1.5-9/35/AL	1.5	1440	9	35	42.5	400	④
			Axis-FP 630-4D/2.2-9/40/AL	2.2	1440	9	40	48.5	400	⑤
			Axis-FP 630-4D/2.2-9/45/AL	2.2	1440	9	45	48.5	400	⑥

Standard size: 630
Number of poles: 2
Fire resistance rating: 400/2

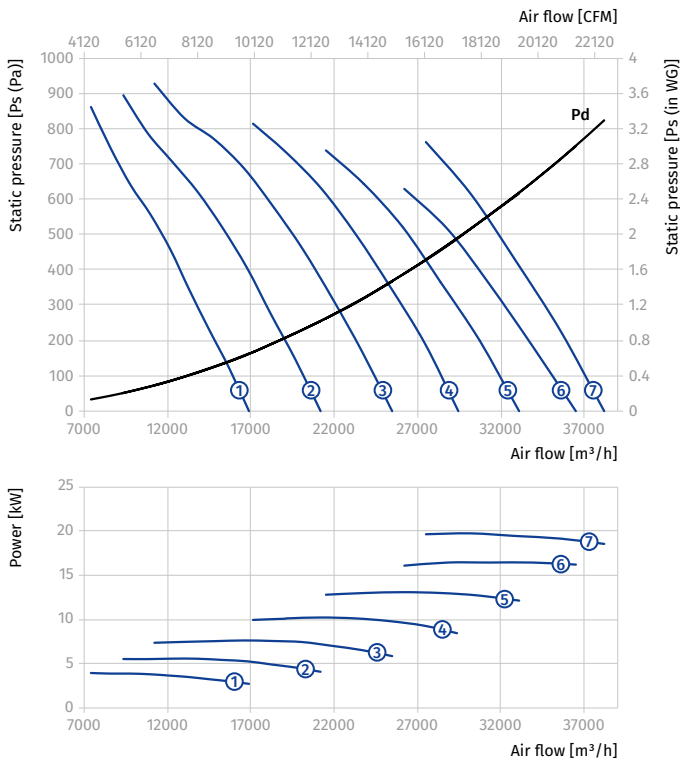

Standard size: 630
Number of poles: 4
Fire resistance rating: 400/2

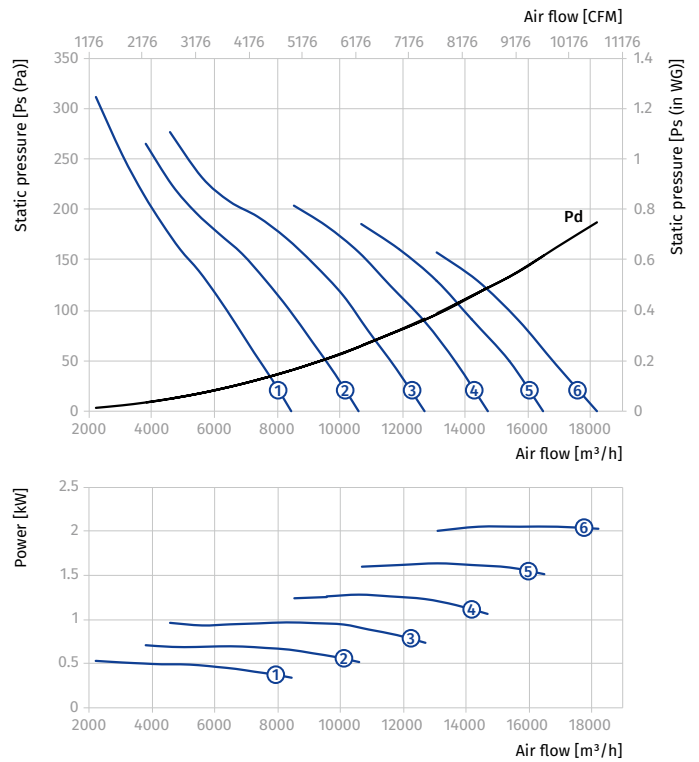

AXIS-FP 630...400/2

Size	Number of poles	Voltage [V/50 Hz]	Fan model	Installed motor power N_y [kW]	RPM [min^{-1}]	Number of blades	Blade setting angle [°]	Weight [kg]	Length L [mm]	Curve number on graph
Axis-FP 630-2/4D...400/2										
630	2/4	3~400	Axis-FP 630-2/4D/4.4/1.1-9/20/AL	4.4/1.1	2880/1440	9	20	73	500	①
			Axis-FP 630-2/4D/6/1.5-9/25/AL	6/1.5	2880/1440	9	25	102.5	550	②
			Axis-FP 630-2/4D/8/2-9/30/AL	8/2	2880/1440	9	30	111.5	550	③
			Axis-FP 630-2/4D/12/3-9/35/AL	12/3	2880/1440	9	35	176	700	④
			Axis-FP 630-2/4D/16/4-9/40/AL	16/4	2880/1440	9	40	193	700	⑤
			Axis-FP 630-2/4D/16/4-9/45/AL	16/4	2880/1440	9	45	193	700	⑥

Standard size: 630
 Number of poles: 2
 Fire resistance rating: 400/2

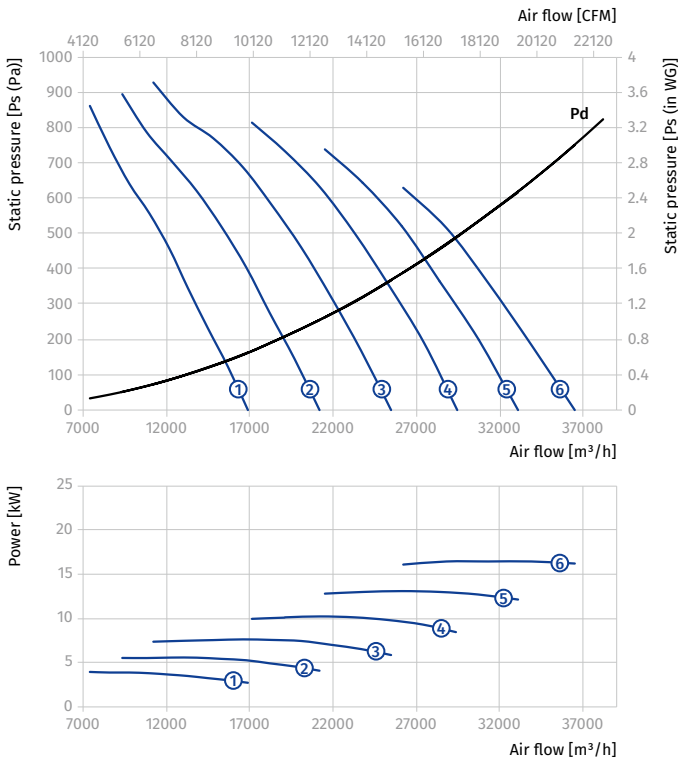

Standard size: 630
 Number of poles: 4
 Fire resistance rating: 400/2

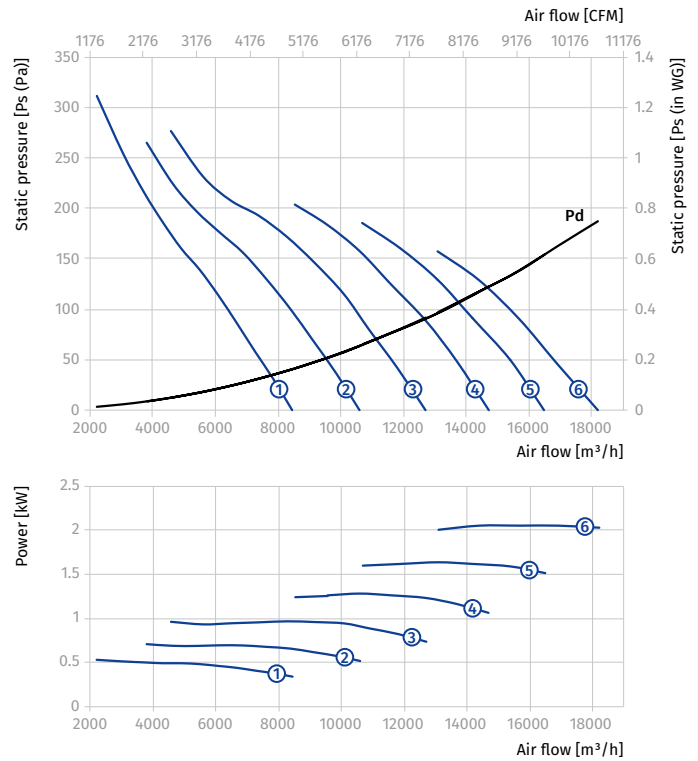

AXIS-FP 630...400/2

Size	Number of poles	Voltage [V/50 Hz]	Fan model	Installed motor power Ny [kW]	RPM [min ⁻¹]	Number of blades	Blade setting angle [°]	Weight [kg]	Length L [mm]	Curve number on graph
Axis-FP 630-4/6D...400/2										
630	4/6	3~400	Axis-FP 630-4/6D/0.55/0.2-9/20/AL	0.55/0.2	1440/960	9	20	37	400	①
			Axis-FP 630-4/6D/0.75/0.25-9/25/AL	0.75/0.25	1440/960	9	25	37	400	②
			Axis-FP 630-4/6D/1.1/0.3-9/30/AL	1.1/0.3	1440/960	9	30	41.5	400	③
			Axis-FP 630-4/6D/1.5/0.37-9/35/AL	1.5/0.37	1440/960	9	35	45.5	400	④
			Axis-FP 630-4/6D/2.2/0.7-9/40/AL	2.2/0.7	1440/960	9	40	57	500	⑤
			Axis-FP 630-4/6D/2.2/0.7-9/45/AL	2.2/0.7	1440/960	9	45	57	500	⑥

Standard size: 630
Number of poles: 4
Fire resistance rating: 400/2

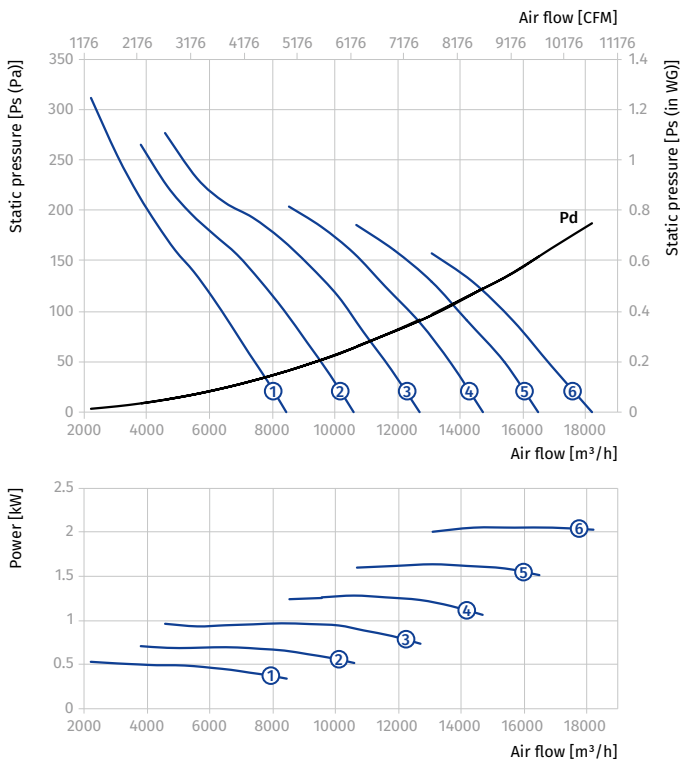

Standard size: 630
Number of poles: 6
Fire resistance rating: 400/2

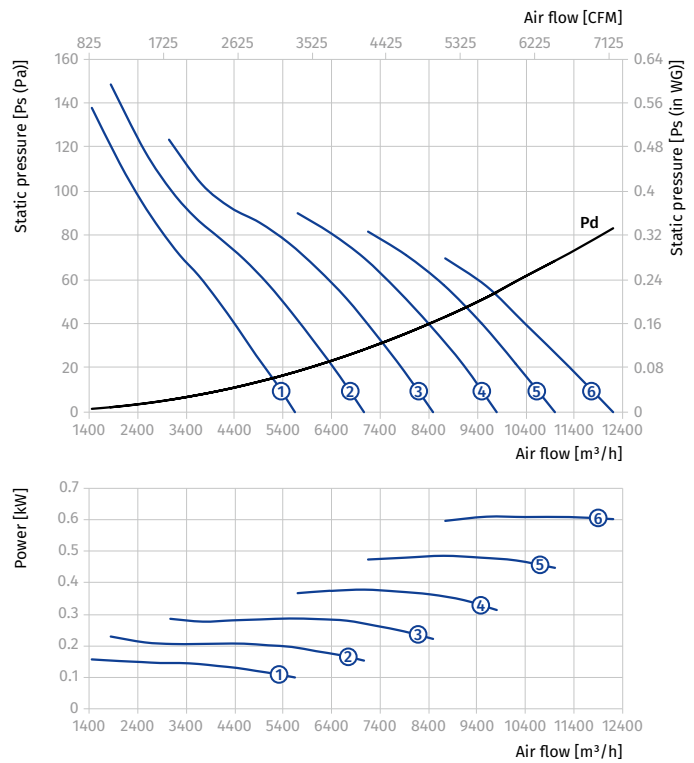

AXIS-FP 630...400/2

Size	Number of poles	Voltage [V/50 Hz]	Fan model	Installed motor power N_y [kW]	RPM [min^{-1}]	Number of blades	Blade setting angle [°]	Weight [kg]	Length L [mm]	Curve number on graph
Axis-FP 630-4/8D...400/2										
630	4/8	3~400	Axis-FP 630-4/8D/0.6/0.15-9/20/AL	0.6/0.15	1440/720	9	20	39	400	①
			Axis-FP 630-4/8D/0.8/0.2-9/25/AL	0.8/0.2	1440/720	9	25	39	400	②
			Axis-FP 630-4/8D/1.2/0.3-9/30/AL	1.2/0.3	1440/720	9	30	45.5	400	③
			Axis-FP 630-4/8D/1.6/0.4-9/35/AL	1.6/0.4	1440/720	9	35	48.5	400	④
			Axis-FP 630-4/8D/2.2/0.55-9/40/AL	2.2/0.55	1440/720	9	40	60	500	⑤
			Axis-FP 630-4/8D/2.2/0.55-9/45/AL	2.2/0.55	1440/720	9	45	60	500	⑥

Standard size: 630
 Number of poles: 4
 Fire resistance rating: 400/2

Standard size: 630
 Number of poles: 8
 Fire resistance rating: 400/2

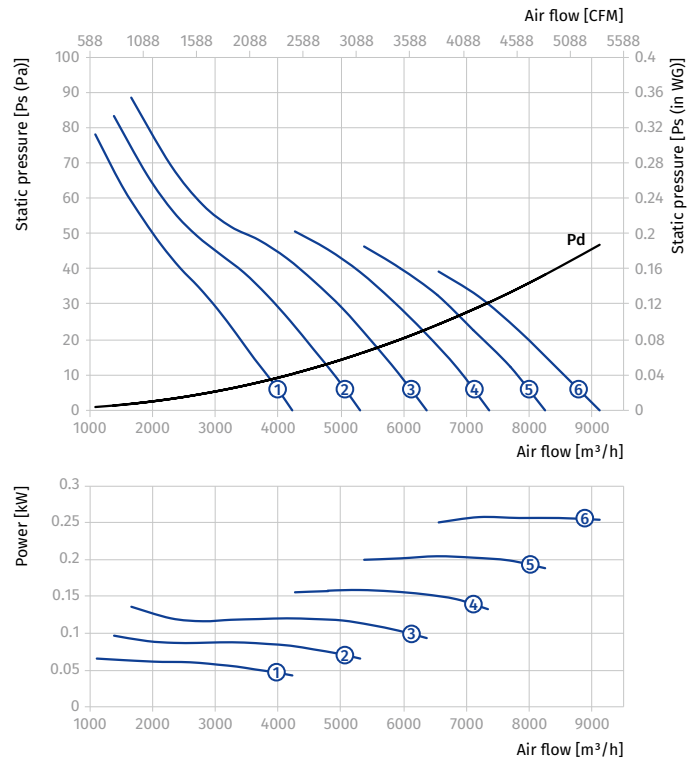
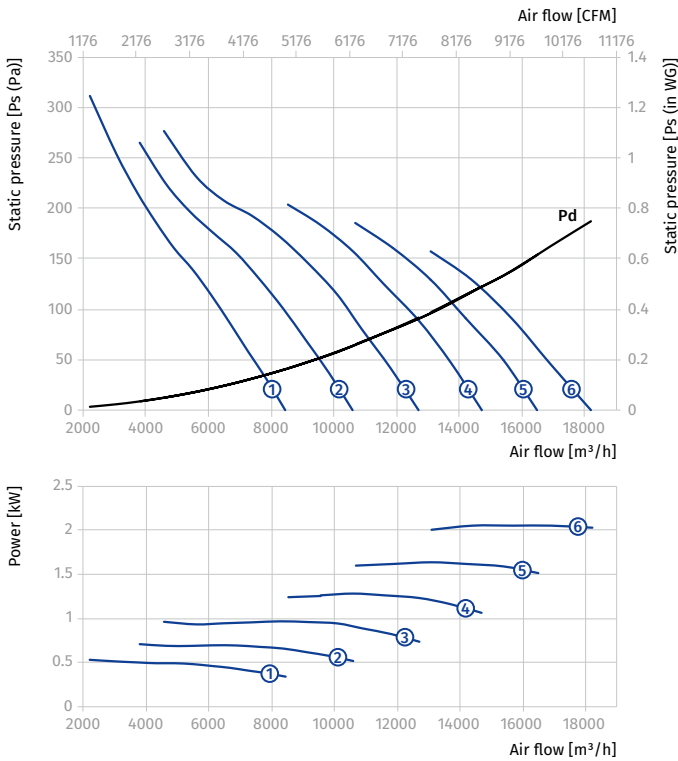

AXIS-FP 710...400/2

Size	Number of poles	Voltage [V/50 Hz]	Fan model	Installed motor power Ny [kW]	RPM [min ⁻¹]	Number of blades	Blade setting angle [°]	Weight [kg]	Length L [mm]	Curve number on graph
Axis-FP 710-4D-1...400/2										
710	4	3~400	Axis-FP 710-4D/1.1-5/20/AL	1.1	1440	5	20	57.5	400	①
			Axis-FP 710-4D/1.5-5/25/AL	1.5	1440	5	25	61	450	②
			Axis-FP 710-4D/2.2-5/30/AL	2.2	1440	5	30	67	450	③
			Axis-FP 710-4D/3-5/35/AL	3	1440	5	35	81	550	④
			Axis-FP 710-4D/3-5/40/AL	3	1440	5	40	81	550	⑤
Axis-FP 710-4D-2...400/2										
710	4	3~400	Axis-FP 710-4D/0.75-9/20/AL	0.75	1440	9	20	47	400	①
			Axis-FP 710-4D/1.1-9/25/AL	1.1	1440	9	25	51.5	400	②
			Axis-FP 710-4D/1.5-9/30/AL	1.5	1440	9	30	55	400	③
			Axis-FP 710-4D/2.2-9/35/AL	2.2	1440	9	35	61	400	④
			Axis-FP 710-4D/3-9/40/AL	3	1440	9	40	75	500	⑤
			Axis-FP 710-4D/3-9/45/AL	3	1440	9	45	75	500	⑥

Standard size: 710
Number of poles: 4
Fire resistance rating: 400/2

Standard size: 710
Number of poles: 4
Fire resistance rating: 400/2

AXIAL SMOKE EXTRACTION FANS

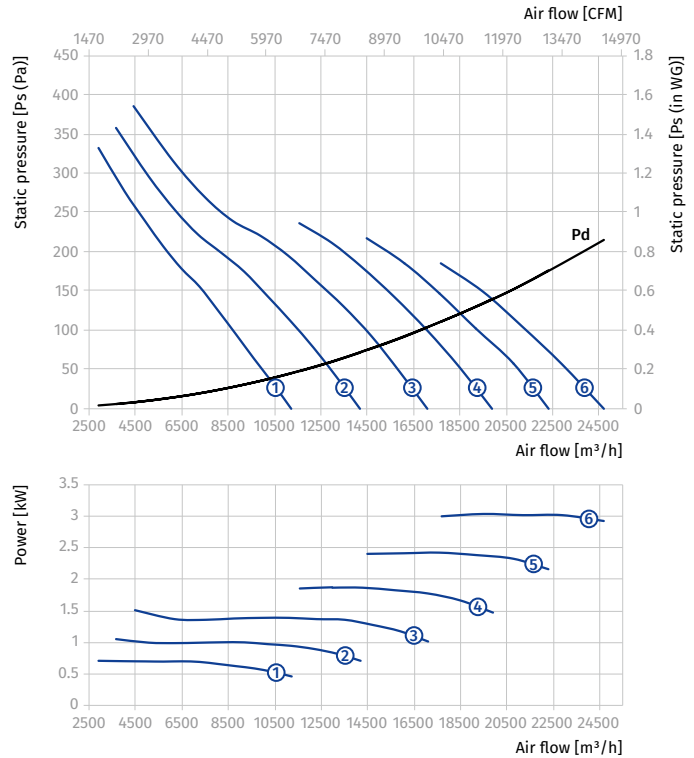
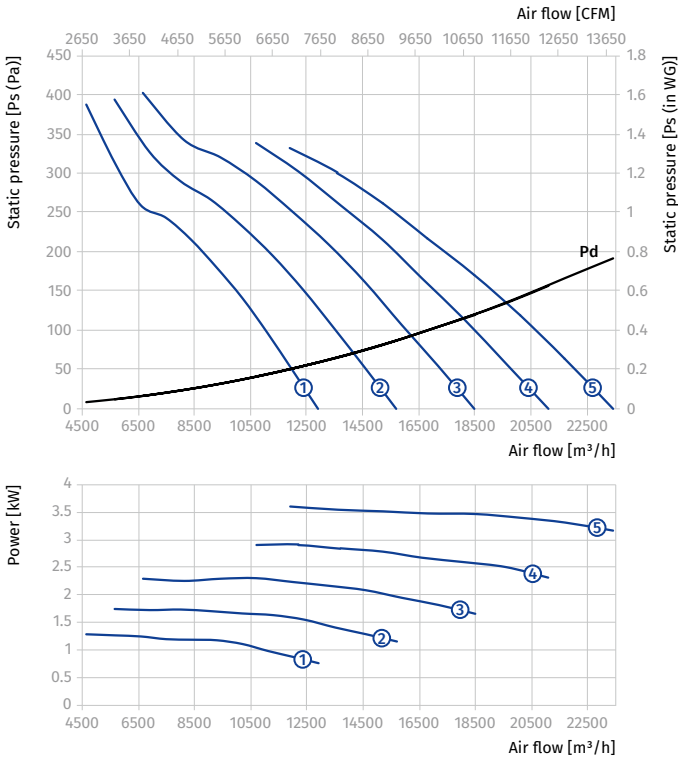

AXIS-FP 710...400/2

Size	Number of poles	Voltage [V/50 Hz]	Fan model	Installed motor power N_y [kW]	RPM [min^{-1}]	Number of blades	Blade setting angle [°]	Weight [kg]	Length L [mm]	Curve number on graph
Axis-FP 710-6D-1...400/2										
710	6	3~400	Axis-FP 710-6D/0.37-5/20/AL	0.37	960	5	20	55	400	①
			Axis-FP 710-6D/0.55-5/25/AL	0.55	960	5	25	58.5	400	②
			Axis-FP 710-6D/0.75-5/30/AL	0.75	960	5	30	62	450	③
			Axis-FP 710-6D/0.75-5/35/AL	0.75	960	5	35	62	450	④
			Axis-FP 710-6D/1.1-5/40/AL	1.1	960	5	40	66	450	⑤
Axis-FP 710-6D-2...400/2										
710	6	3~400	Axis-FP 710-6D/0.37-9/20/AL	0.37	960	9	20	49	400	①
			Axis-FP 710-6D/0.37-9/25/AL	0.37	960	9	25	49	400	②
			Axis-FP 710-6D/0.55-9/30/AL	0.55	960	9	30	52.5	400	③
			Axis-FP 710-6D/0.55-9/35/AL	0.55	960	9	35	52.5	400	④
			Axis-FP 710-6D/0.75-9/40/AL	0.75	960	9	40	56	400	⑤
			Axis-FP 710-6D/1.1-9/45/AL	1.1	960	9	45	60	400	⑥

Standard size: 710
 Number of poles: 6
 Fire resistance rating: 400/2

Standard size: 710
 Number of poles: 6
 Fire resistance rating: 400/2

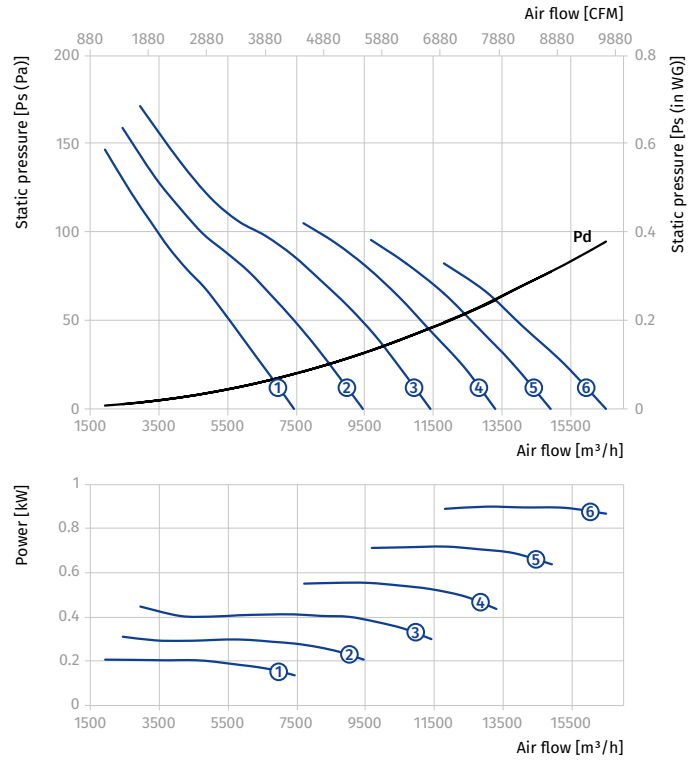
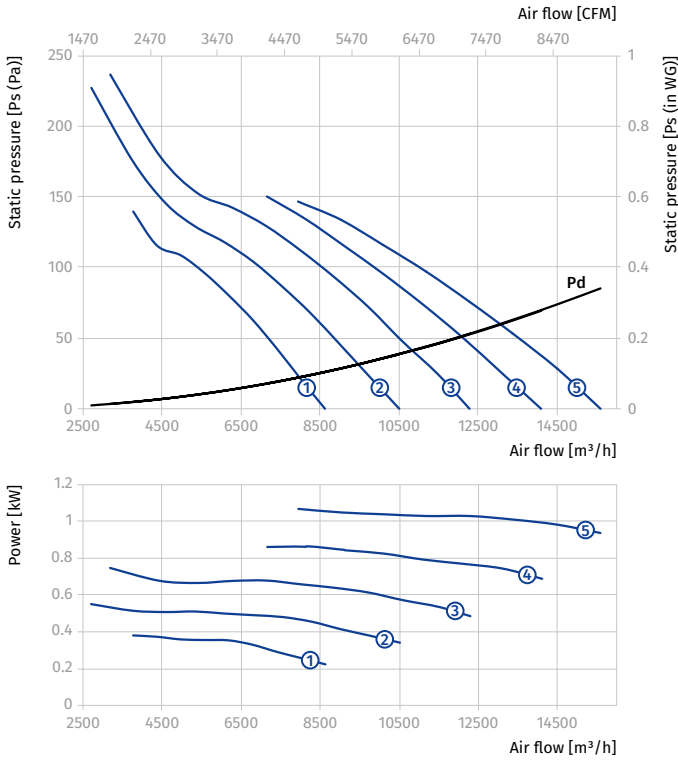

AXIS-FP 710...400/2

Size	Number of poles	Voltage [V/50 Hz]	Fan model	Installed motor power Ny [kW]	RPM [min ⁻¹]	Number of blades	Blade setting angle [°]	Weight [kg]	Length L [mm]	Curve number on graph
Axis-FP 710-4/6D-1...400/2										
710	4/6	3~400	Axis-FP 710-4/6D/1.1/0.3-5/20/AL	1.1/0.3	1440/960	5	20	60	450	①
			Axis-FP 710-4/6D/1.5/0.37-5/25/AL	1.5/0.37	1440/960	5	25	64	450	②
			Axis-FP 710-4/6D/2.2/0.7-5/30/AL	2.2/0.7	1440/960	5	30	77.5	550	③
			Axis-FP 710-4/6D/3/1-5/35/AL	3/1	1440/960	5	35	86.5	550	④
			Axis-FP 710-4/6D/3/1-5/40/AL	3/1	1440/960	5	40	86.5	550	⑤

Standard size: 710
Number of poles: 4
Fire resistance rating: 400/2

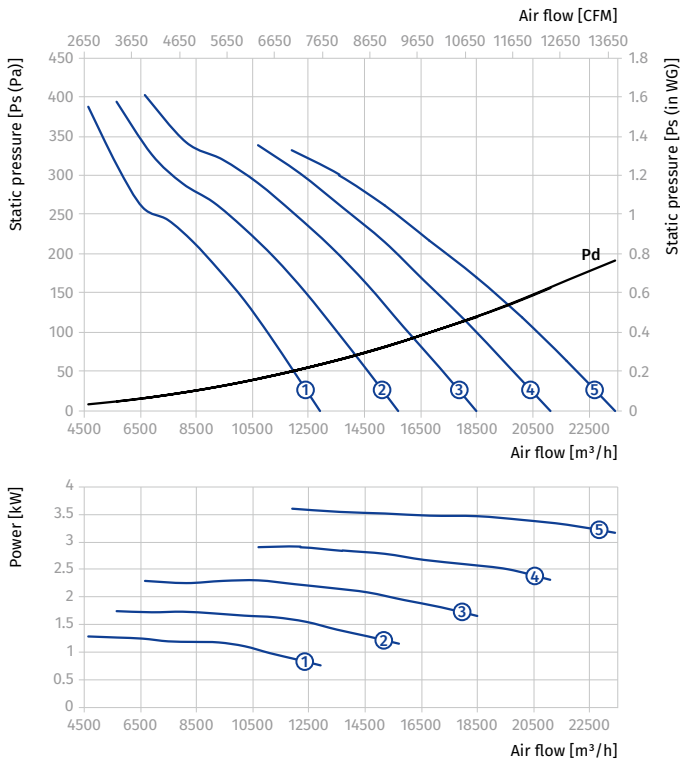

Standard size: 710
Number of poles: 6
Fire resistance rating: 400/2

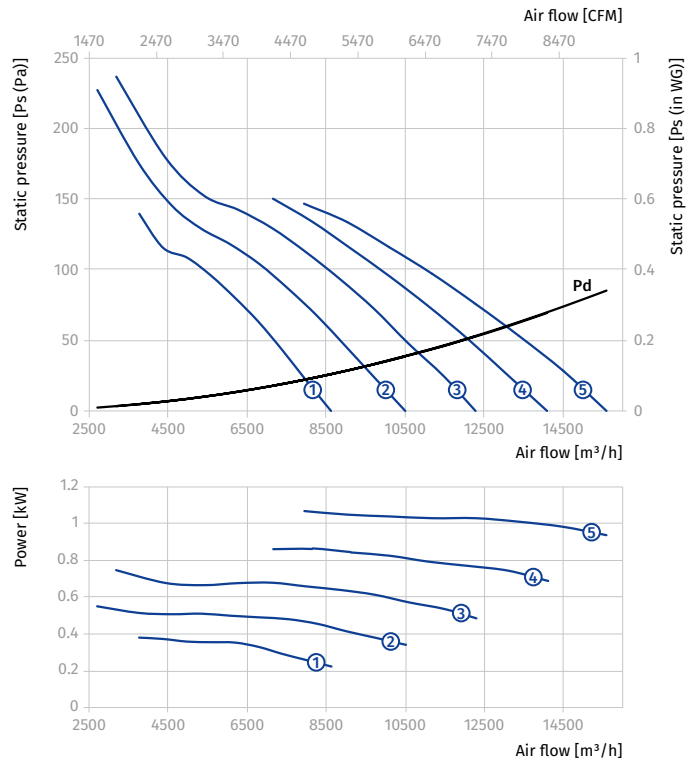

AXIS-FP 710...400/2

Size	Number of poles	Voltage [V/50 Hz]	Fan model	Installed motor power N_y [kW]	RPM [min ⁻¹]	Number of blades	Blade setting angle [°]	Weight [kg]	Length L [mm]	Curve number on graph
Axis-FP 710-4/6D-2...400/2										
710	4/6	3~400	Axis-FP 710-4/6D/0.75/0.25-9/20/AL	0.75/0.25	1440/960	9	20	49	400	①
			Axis-FP 710-4/6D/1.1/0.3-9/25/AL	1.1/0.3	1440/960	9	25	54	400	②
			Axis-FP 710-4/6D/1.5/0.37-9/30/AL	1.5/0.37	1440/960	9	30	58	400	③
			Axis-FP 710-4/6D/2.2/0.7-9/35/AL	2.2/0.7	1440/960	9	35	71.5	500	④
			Axis-FP 710-4/6D/3/1-9/40/AL	3/1	1440/960	9	40	80.5	500	⑤
			Axis-FP 710-4/6D/3/1-9/45/AL	3/1	1440/960	9	45	80.5	500	⑥

Standard size: 710
 Number of poles: 4
 Fire resistance rating: 400/2

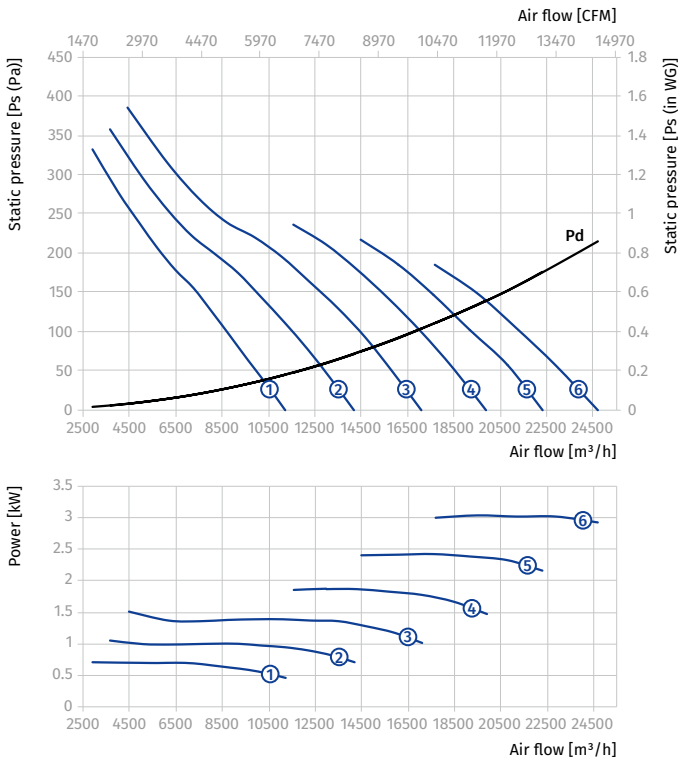

Standard size: 710
 Number of poles: 6
 Fire resistance rating: 400/2

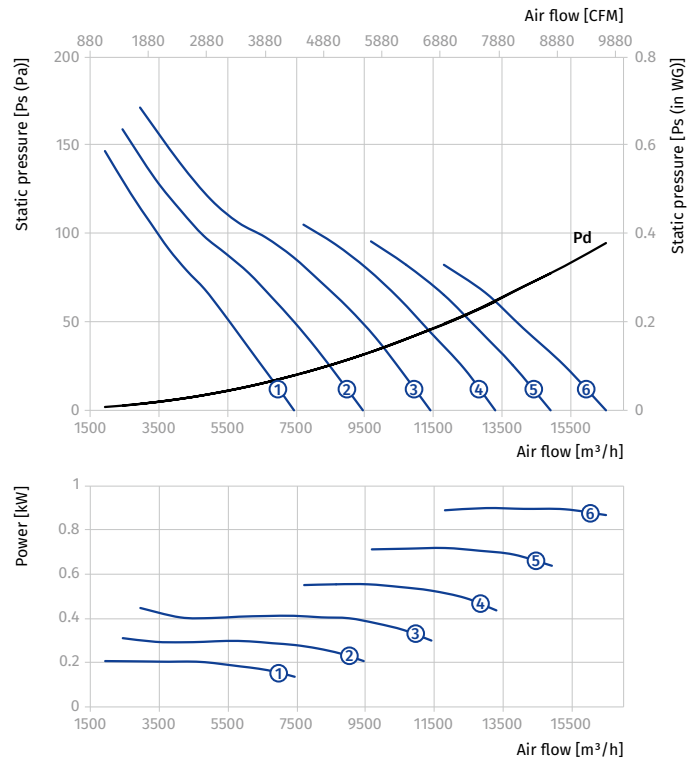

AXIS-FP 710...400/2

Size	Number of poles	Voltage [V/50 Hz]	Fan model	Installed motor power Ny [kW]	RPM [min ⁻¹]	Number of blades	Blade setting angle [°]	Weight [kg]	Length L [mm]	Curve number on graph
Axis-FP 710-4/8D-1...400/2										
710	4/8	3~400	Axis-FP 710-4/8D/1.2/0.3-5/20/AL	1.2/0.3	1440/720	5	20	64	450	①
			Axis-FP 710-4/8D/1.6/0.4-5/25/AL	1.6/0.4	1440/720	5	25	67	450	②
			Axis-FP 710-4/8D/2.2/0.55-5/30/AL	2.2/0.55	1440/720	5	30	80.5	550	③
			Axis-FP 710-4/8D/2.8/0.7-5/35/AL	2.8/0.7	1440/720	5	35	83.5	550	④
			Axis-FP 710-4/8D/3.8/1-5/40/AL	3.8/1	1440/720	5	40	93.5	550	⑤

Standard size: 710
Number of poles: 4
Fire resistance rating: 400/2

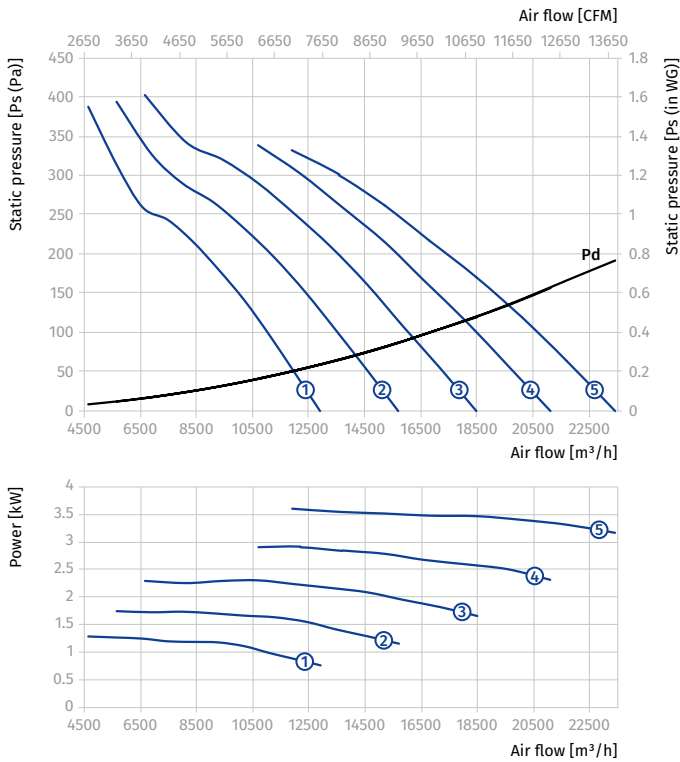

Standard size: 710
Number of poles: 8
Fire resistance rating: 400/2

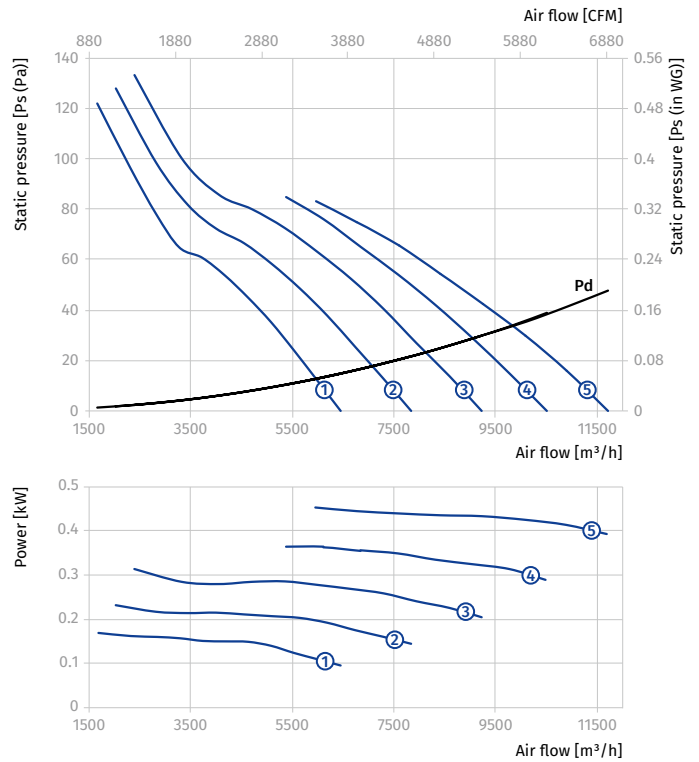

AXIS-FP 710...400/2

Size	Number of poles	Voltage [V/50 Hz]	Fan model	Installed motor power N_y [kW]	RPM [min ⁻¹]	Number of blades	Blade setting angle [°]	Weight [kg]	Length L [mm]	Curve number on graph
Axis-FP 710-4/8D-2...400/2										
710	4/8	3~400	Axis-FP 710-4/8D/0.8/0.2-9/20/AL	0.8/0.2	1440/720	9	20	52	400	①
			Axis-FP 710-4/8D/1.2/0.3-9/25/AL	1.2/0.3	1440/720	9	25	58	400	②
			Axis-FP 710-4/8D/1.6/0.4-9/30/AL	1.6/0.4	1440/720	9	30	61	400	③
			Axis-FP 710-4/8D/2.2/0.55-9/35/AL	2.2/0.55	1440/720	9	35	74.5	500	④
			Axis-FP 710-4/8D/2.8/0.7-9/40/AL	2.8/0.7	1440/720	9	40	77.5	500	⑤
			Axis-FP 710-4/8D/3.8/1-9/45/AL	3.8/1	1440/720	9	45	87.5	500	⑥

Standard size: 710
 Number of poles: 4
 Fire resistance rating: 400/2

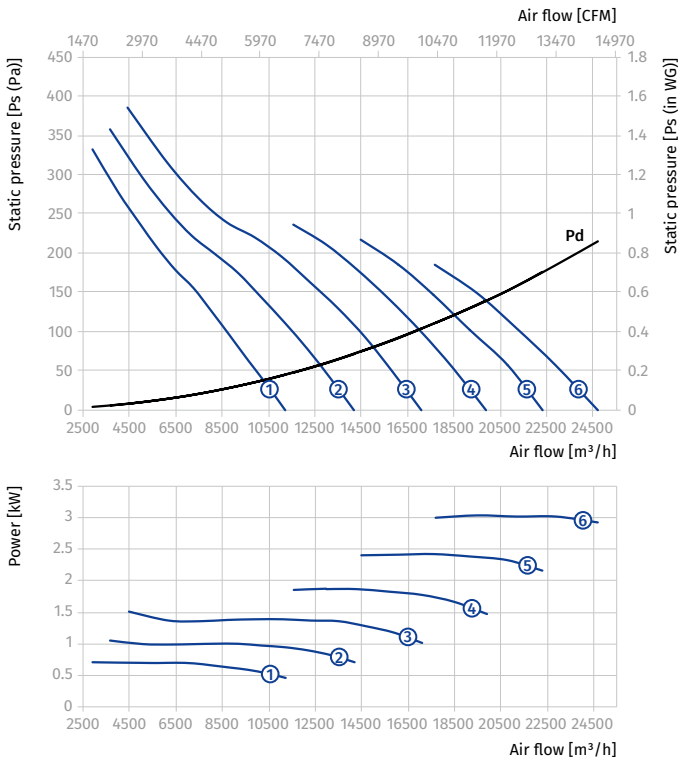

Standard size: 710
 Number of poles: 8
 Fire resistance rating: 400/2

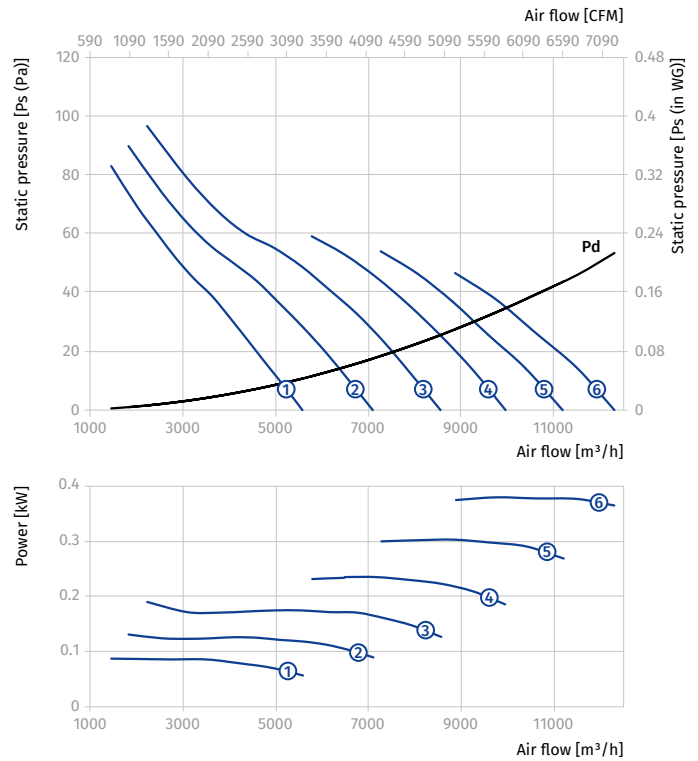

AXIS-FP 800...400/2

Size	Number of poles	Voltage [V/50 Hz]	Fan model	Installed motor power Ny [kW]	RPM [min ⁻¹]	Number of blades	Blade setting angle [°]	Weight [kg]	Length L [mm]	Curve number on graph
Axis-FP 800-4D-1...400/2										
800	4	3~400	Axis-FP 800-4D/1.5-5/20/AL	1.5	1440	5	20	70.5	450	①
			Axis-FP 800-4D/2.2-5/25/AL	2.2	1440	5	25	76.5	450	②
			Axis-FP 800-4D/3-5/30/AL	3	1440	5	30	91.5	550	③
			Axis-FP 800-4D/4-5/35/AL	4	1440	5	35	96.5	550	④
			Axis-FP 800-4D/5.5-5/40/AL	5.5	1440	5	40	115.5	600	⑤
Axis-FP 800-4D-2...400/2										
800	4	3~400	Axis-FP 800-4D/1.1-9/20/AL	1.1	1440	9	20	55.5	400	①
			Axis-FP 800-4D/1.5-9/25/AL	1.5	1440	9	25	59	400	②
			Axis-FP 800-4D/2.2-9/30/AL	2.2	1440	9	30	65	400	③
			Axis-FP 800-4D/3-9/35/AL	3	1440	9	35	79.5	500	④
			Axis-FP 800-4D/4-9/40/AL	4	1440	9	40	84.5	500	⑤
			Axis-FP 800-4D/5.5-9/45/AL	5.5	1440	9	45	104	550	⑥

Standard size: 800
Number of poles: 4
Fire resistance rating: 400/2

Standard size: 800
Number of poles: 4
Fire resistance rating: 400/2

AXIAL SMOKE EXTRACTION FANS

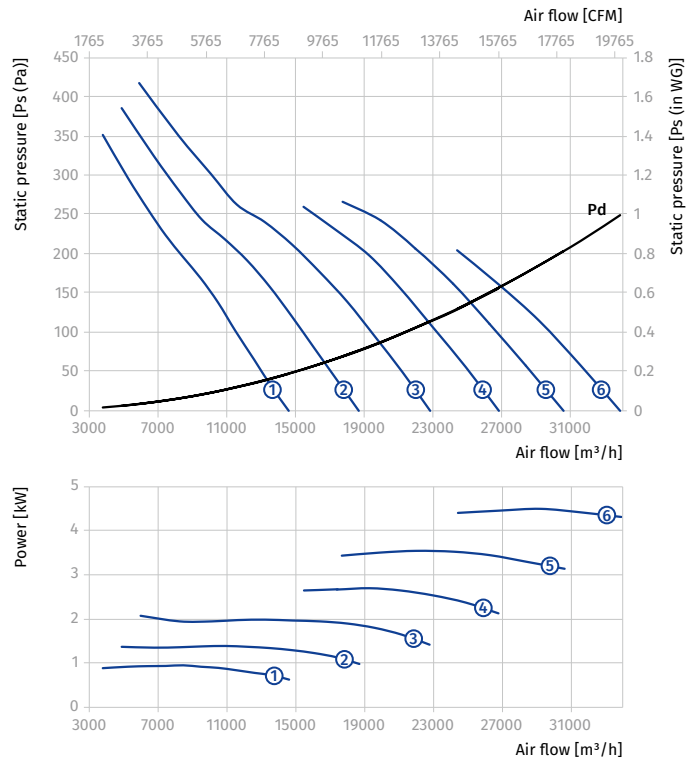
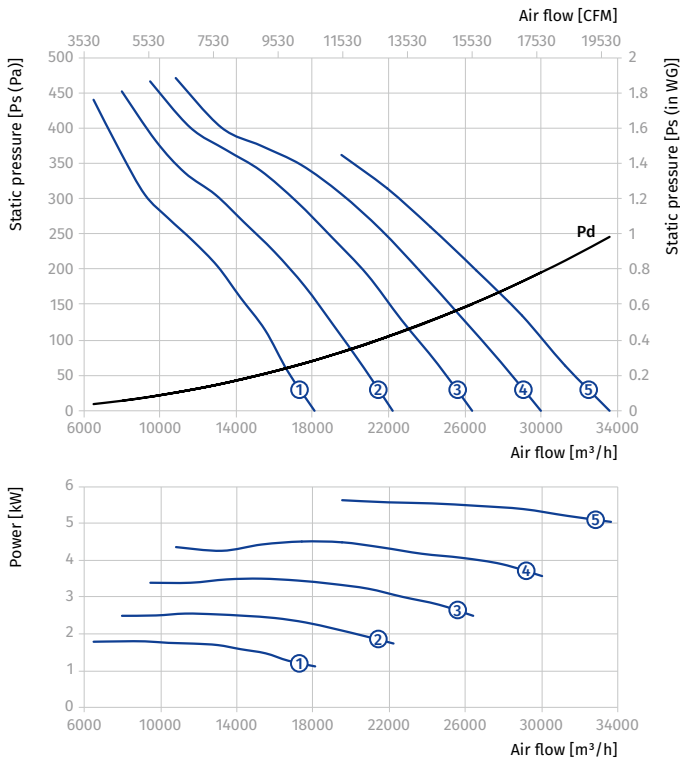

AXIS-FP 800...400/2

Size	Number of poles	Voltage [V/50 Hz]	Fan model	Installed motor power N_y [kW]	RPM [min^{-1}]	Number of blades	Blade setting angle [°]	Weight [kg]	Length L [mm]	Curve number on graph
Axis-FP 800-6D-1...400/2										
800	6	3~400	Axis-FP 800-6D/0.55-5/20/AL	0.55	960	5	20	65	400	①
			Axis-FP 800-6D/0.75-5/25/AL	0.75	960	5	25	71.5	450	②
			Axis-FP 800-6D/1.1-5/30/AL	1.1	960	5	30	75.5	450	③
			Axis-FP 800-6D/1.1-5/35/AL	1.1	960	5	35	75.5	450	④
			Axis-FP 800-6D/1.5-5/40/AL	1.5	960	5	40	88.5	550	⑤
Axis-FP 800-6D-2...400/2										
800	6	3~400	Axis-FP 800-6D/0.37-9/20/AL	0.37	960	9	20	53	400	①
			Axis-FP 800-6D/0.55-9/25/AL	0.55	960	9	25	56.5	400	②
			Axis-FP 800-6D/0.75-9/30/AL	0.75	960	9	30	60	400	③
			Axis-FP 800-6D/1.1-9/35/AL	1.1	960	9	35	64	400	④
			Axis-FP 800-6D/1.1-9/40/AL	1.1	960	9	40	64	400	⑤
			Axis-FP 800-6D/1.5-9/45/AL	1.5	960	9	45	76.5	500	⑥

Standard size: 800
 Number of poles: 6
 Fire resistance rating: 400/2

Standard size: 800
 Number of poles: 6
 Fire resistance rating: 400/2

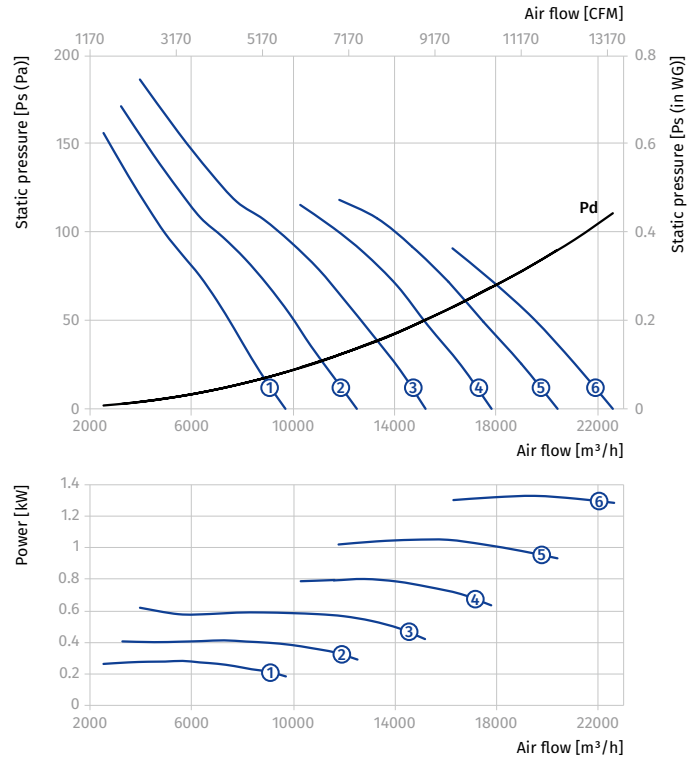
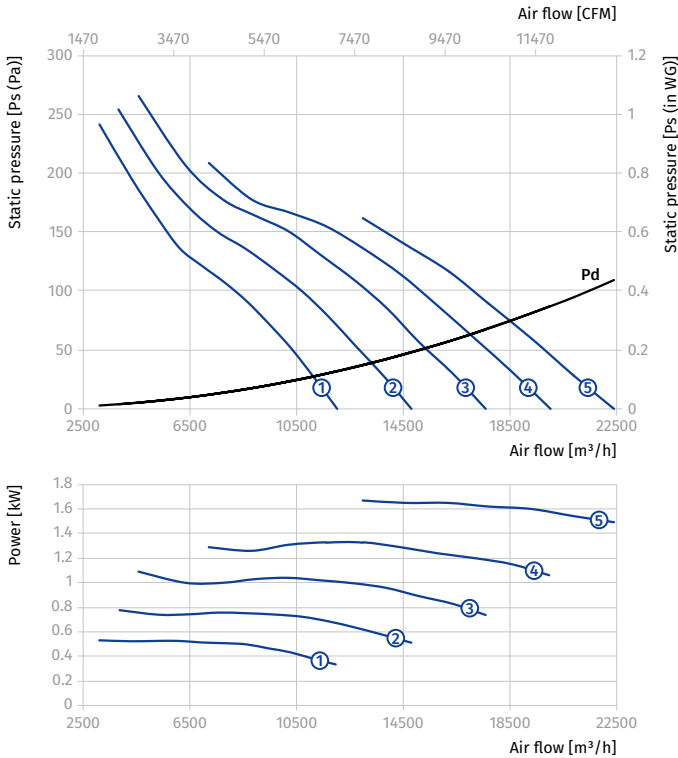

AXIS-FP 800...400/2

Size	Number of poles	Voltage [V/50 Hz]	Fan model	Installed motor power Ny [kW]	RPM [min ⁻¹]	Number of blades	Blade setting angle [°]	Weight [kg]	Length L [mm]	Curve number on graph
Axis-FP 800-4/6D-1...400/2										
800	4/6	3~400	Axis-FP 800-4/6D/1.5/0.37-5/20/AL	1.5/0.37	1440/960	5	20	73.5	450	①
			Axis-FP 800-4/6D/2.2/0.7-5/25/AL	2.2/0.7	1440/960	5	25	88.5	450	②
			Axis-FP 800-4/6D/3/1-5/30/AL	3/1	1440/960	5	30	99.5	550	③
			Axis-FP 800-4/6D/4.5/1.5-5/35/AL	4.5/1.5	1440/960	5	35	136.5	600	④
			Axis-FP 800-4/6D/6/2.2-5/40/AL	6/2.2	1440/960	5	40	147.5	600	⑤

Standard size: **800**
Number of poles: **4**
Fire resistance rating: **400/2**

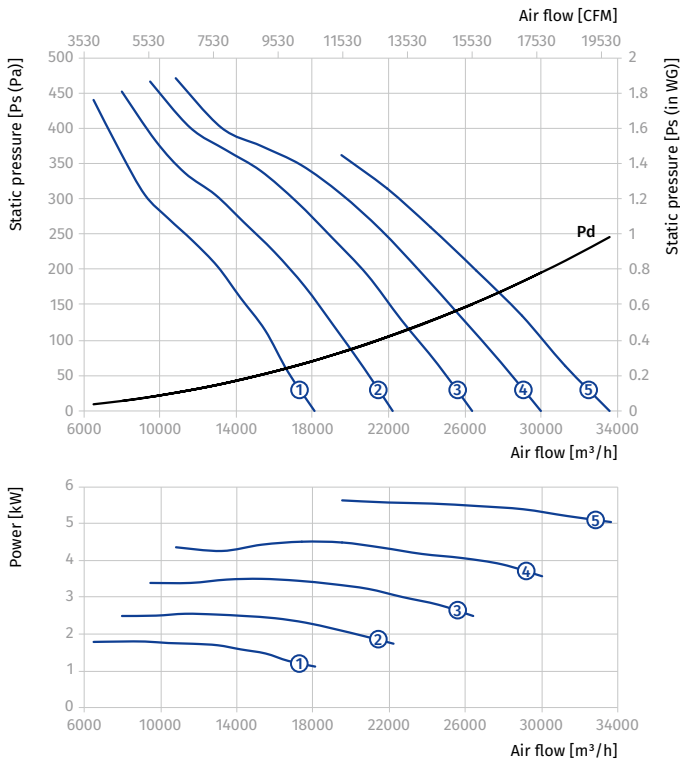

Standard size: **800**
Number of poles: **6**
Fire resistance rating: **400/2**

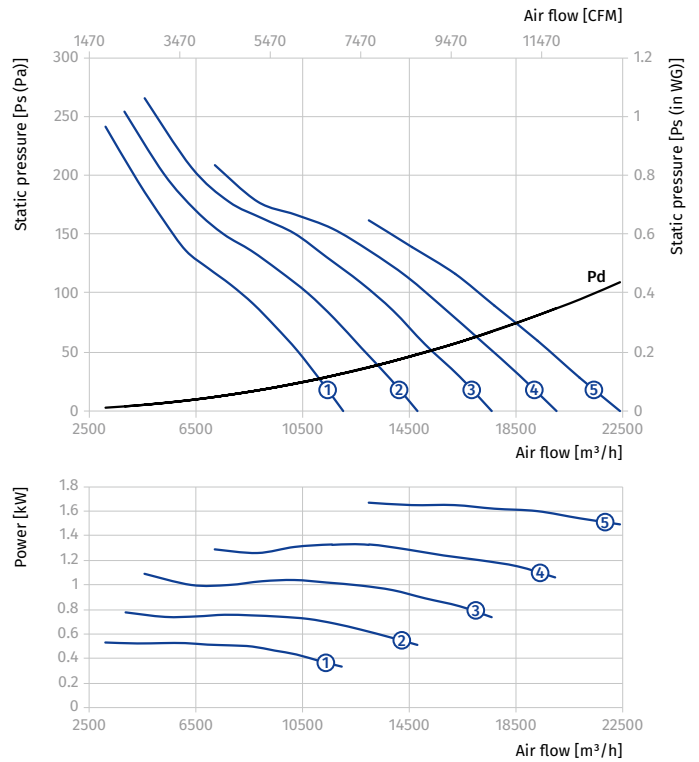

AXIS-FP 800...400/2

Size	Number of poles	Voltage [V/50 Hz]	Fan model	Installed motor power N_y [kW]	RPM [min ⁻¹]	Number of blades	Blade setting angle [°]	Weight [kg]	Length L [mm]	Curve number on graph
Axis-FP 800-4/6D-2...400/2										
800	4/6	3~400	Axis-FP 800-4/6D/1.1/0.3-9/20/AL	1.1/0.3	1440/960	9	20	58	400	①
			Axis-FP 800-4/6D/1.5/0.37-9/25/AL	1.5/0.37	1440/960	9	25	62	400	②
			Axis-FP 800-4/6D/2.2/0.7-9/30/AL	2.2/0.7	1440/960	9	30	76.5	500	③
			Axis-FP 800-4/6D/3/1-9/35/AL	3/1	1440/960	9	35	87.5	500	④
			Axis-FP 800-4/6D/4.5/1.5-9/40/AL	4.5/1.5	1440/960	9	40	125	550	⑤
			Axis-FP 800-4/6D/4.5/1.5-9/45/AL	4.5/1.5	1440/960	9	45	125	550	⑥

Standard size: 800
 Number of poles: 4
 Fire resistance rating: 400/2

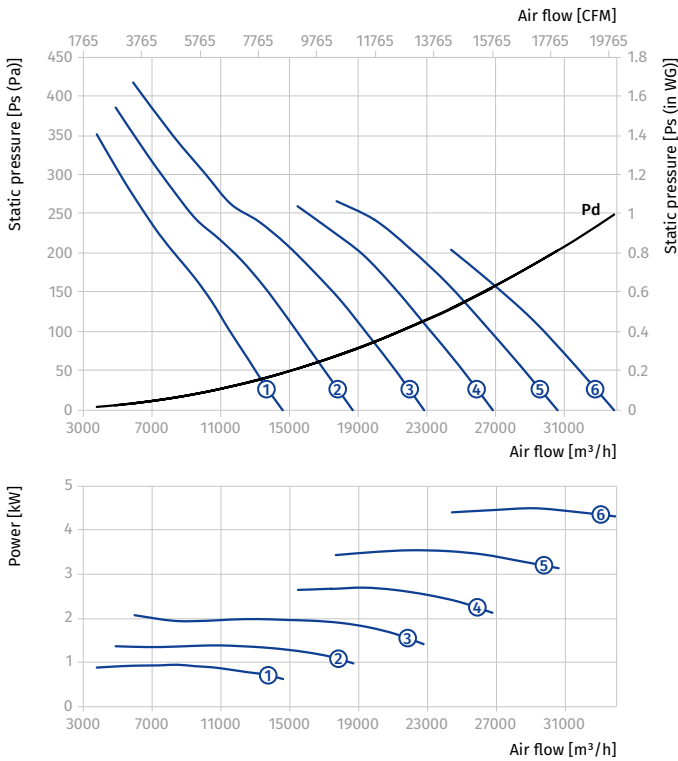

Standard size: 800
 Number of poles: 6
 Fire resistance rating: 400/2

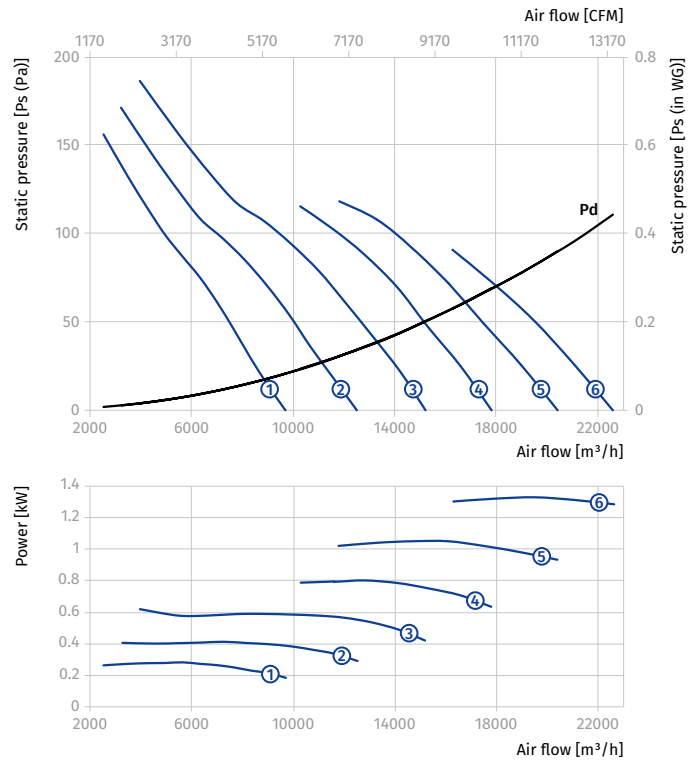

AXIS-FP 800...400/2

Size	Number of poles	Voltage [V/50 Hz]	Fan model	Installed motor power Ny [kW]	RPM [min ⁻¹]	Number of blades	Blade setting angle [°]	Weight [kg]	Length L [mm]	Curve number on graph
Axis-FP 800-4/8D-1...400/2										
800	4/8	3~400	Axis-FP 800-4/8D/1.6/0.4-5/20/AL	1.6/0.4	1440/720	5	20	77	450	①
			Axis-FP 800-4/8D/2.2/0.55-5/25/AL	2.2/0.55	1440/720	5	25	91.5	550	②
			Axis-FP 800-4/8D/2.8/0.7-5/30/AL	2.8/0.7	1440/720	5	30	94.5	550	③
			Axis-FP 800-4/8D/3.8/1-5/35/AL	3.8/1	1440/720	5	35	106.5	550	④
			Axis-FP 800-4/8D/5/1.3-5/40/AL	5/1.3	1440/720	5	40	136.5	600	⑤

Standard size: **800**
Number of poles: **4**
Fire resistance rating: **400/2**

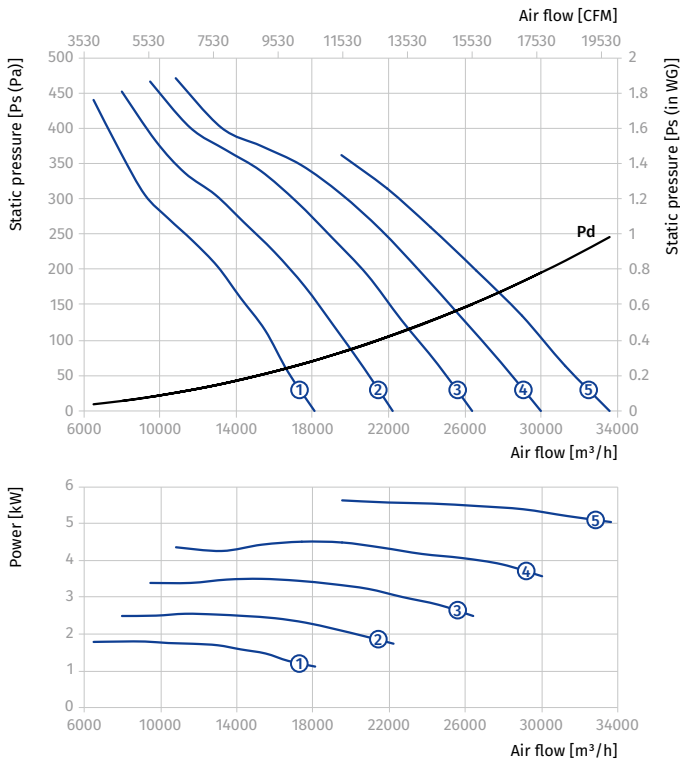

Standard size: **800**
Number of poles: **8**
Fire resistance rating: **400/2**

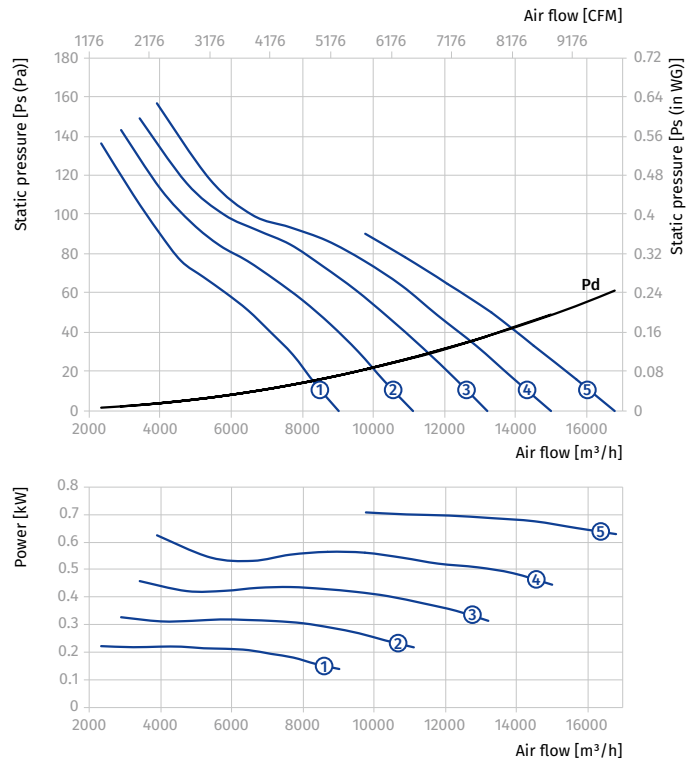

AXIS-FP 800...400/2

Size	Number of poles	Voltage [V/50 Hz]	Fan model	Installed motor power N_y [kW]	RPM [min^{-1}]	Number of blades	Blade setting angle [°]	Weight [kg]	Length L [mm]	Curve number on graph
Axis-FP 800-4/8D-2...400/2										
800	8	3~400	Axis-FP 800-4/8D/1.2/0.3-9/20/AL	1.2/0.3	720	9	20	62	400	①
			Axis-FP 800-4/8D/1.6/0.4-9/25/AL	1.6/0.4	720	9	25	65	400	②
			Axis-FP 800-4/8D/2.2/0.55-9/30/AL	2.2/0.55	720	9	30	79.5	500	③
			Axis-FP 800-4/8D/2.8/0.7-9/35/AL	2.8/0.7	720	9	35	82.5	500	④
			Axis-FP 800-4/8D/3.8/1-9/40/AL	3.8/1	720	9	40	94.5	500	⑤
			Axis-FP 800-4/8D/5/1.3-9/45/AL	5/1.3	720	9	45	125	550	⑥

Standard size: 800
 Number of poles: 4
 Fire resistance rating: 400/2

Standard size: 800
 Number of poles: 8
 Fire resistance rating: 400/2

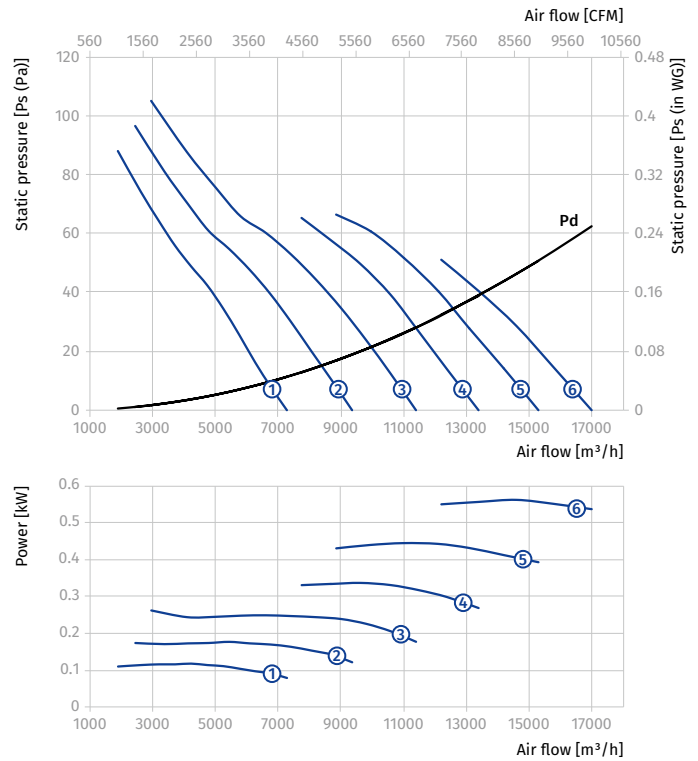
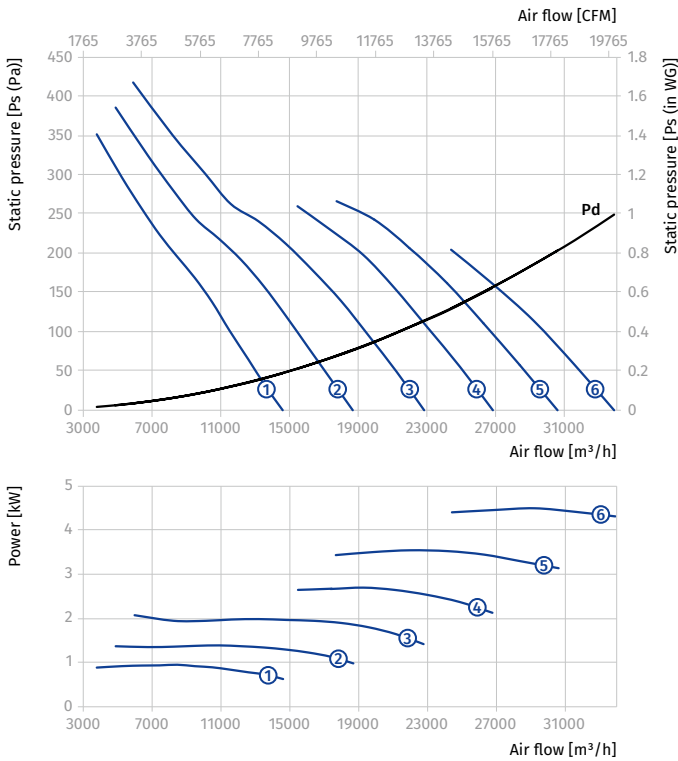

AXIS-FP 900...400/2

Size	Number of poles	Voltage [V/50 Hz]	Fan model	Installed motor power Ny [kW]	RPM [min ⁻¹]	Number of blades	Blade setting angle [°]	Weight [kg]	Length L [mm]	Curve number on graph
Axis-FP 900-4D...400/2										
900	4	3~400	Axis-FP 900-4D/3-6/20/AL	3	1440	6	20	101	550	①
			Axis-FP 900-4D/4-6/25/AL	4	1440	6	25	106	550	②
			Axis-FP 900-4D/5.5-6/29/AL	5.5	1440	6	29	141.5	600	③
			Axis-FP 900-4D/7.5-6/35/AL	7.5	1440	6	35	159	600	④
			Axis-FP 900-4D/9.2-6/39/AL	9.2	1440	6	39	164.5	600	⑤
			Axis-FP 900-4D/11-6/43/AL	11	1440	6	43	177.5	600	⑥
Axis-FP 900-6D...400/2										
900	6	3~400	Axis-FP 900-6D/0.75-5/20/AL	0.75	960	5	20	78	450	①
			Axis-FP 900-6D/1.1-6/24/AL	1.1	960	6	24	84	450	②
			Axis-FP 900-6D/1.5-6/28/AL	1.5	960	6	28	98	550	③
			Axis-FP 900-6D/2.2-6/35/AL	2.2	960	6	35	110	550	④
			Axis-FP 900-6D/3-6/41/AL	3	960	6	41	149.5	600	⑤

Standard size: 900
Number of poles: 4
Fire resistance rating: 400/2

Standard size: 900
Number of poles: 6
Fire resistance rating: 400/2

AXIAL SMOKE EXTRACTION FANS

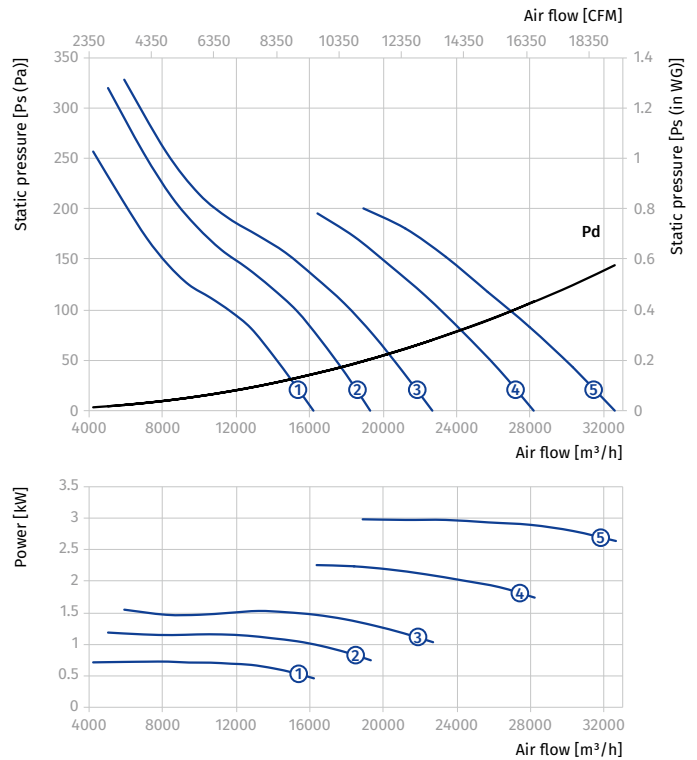
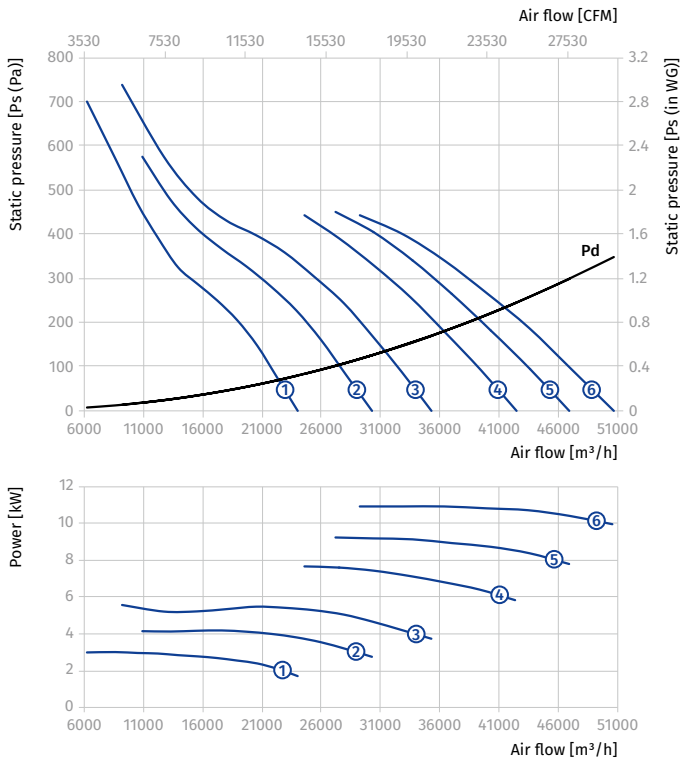

AXIS-FP 900...400/2

Size	Number of poles	Voltage [V/50 Hz]	Fan model	Installed motor power N_y [kW]	RPM [min^{-1}]	Number of blades	Blade setting angle [°]	Weight [kg]	Length L [mm]	Curve number on graph
Axis-FP 900-4/6D...400/2										
900	4/6	3~400	Axis-FP 900-4/6D/3/1-6/20/AL	3/1	1440/960	6	20	109	550	①
			Axis-FP 900-4/6D/4.5/1.5-6/26/AL	4.5/1.5	1440/960	6	26	162.5	600	②
			Axis-FP 900-4/6D/6/2.2-6/31/AL	6/2.2	1440/960	6	31	173.5	600	③
			Axis-FP 900-4/6D/10/3.3-6/41/AL	10/3.3	1440/960	6	41	236.5	750	④

Standard size: 900
 Number of poles: 4
 Fire resistance rating: 400/2

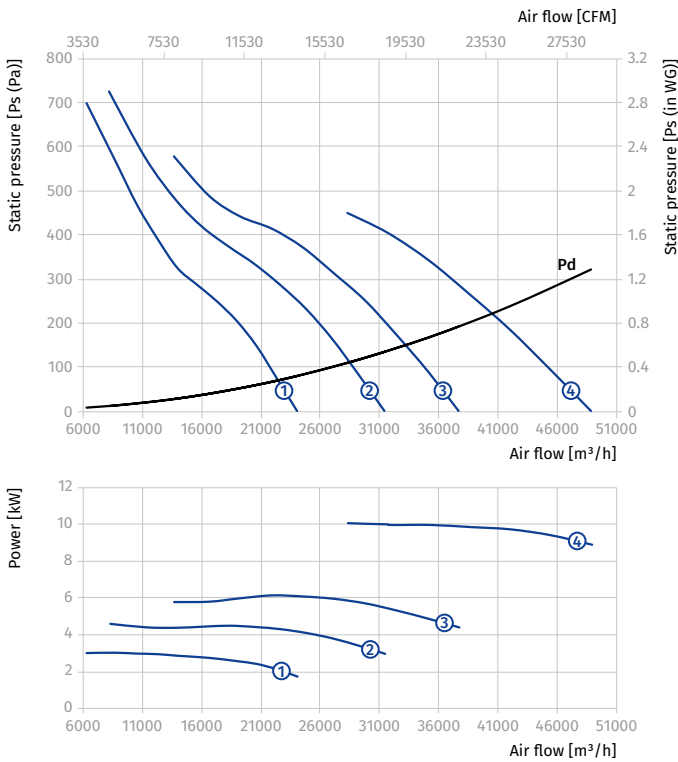

Standard size: 900
 Number of poles: 6
 Fire resistance rating: 400/2

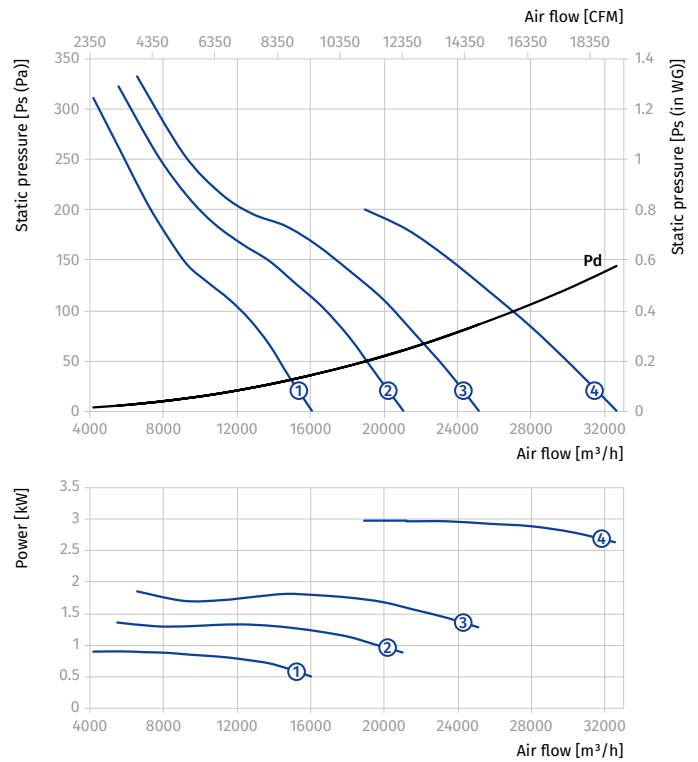

AXIS-FP 900...400/2

Size	Number of poles	Voltage [V/50 Hz]	Fan model	Installed motor power Ny [kW]	RPM [min ⁻¹]	Number of blades	Blade setting angle [°]	Weight [kg]	Length L [mm]	Curve number on graph
Axis-FP 900-4/8D...400/2										
900	4/8	3~400	Axis-FP 900-4/8D/2.8/0.7-6/20/AL	2.8/0.7	1440/720	6	20	104	550	①
			Axis-FP 900-4/8D/3.8/1-6/23/AL	3.8/1	1440/720	6	23	116	550	②
			Axis-FP 900-4/8D/5/1.3-6/28/AL	5/1.3	1440/720	6	28	162.5	600	③
			Axis-FP 900-4/8D/7.2/1.8-6/34/AL	7.2/1.8	1440/720	6	34	174.5	600	④
			Axis-FP 900-4/8D/11/3-6/43/AL	11/3	1440/720	6	43	235.5	750	⑤

Standard size: **900**
Number of poles: **4**
Fire resistance rating: **400/2**

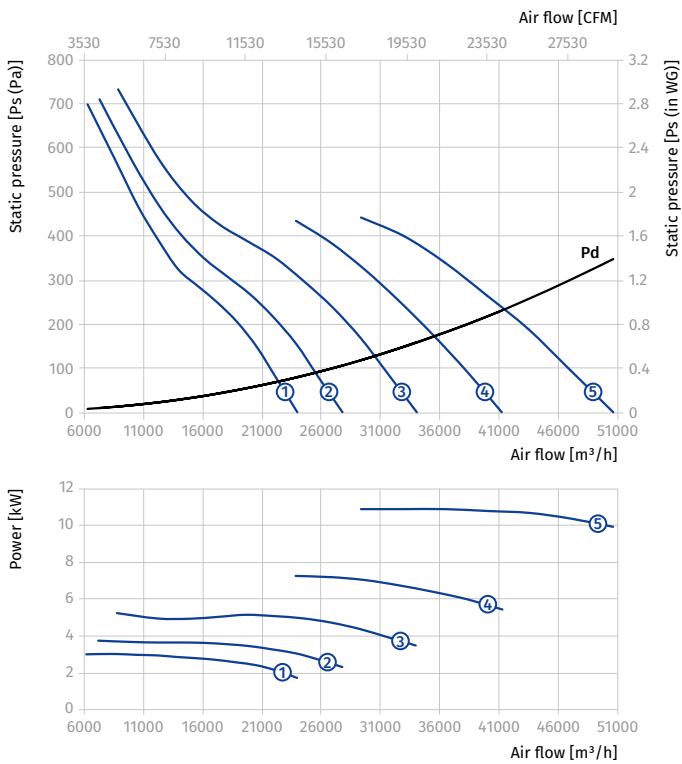

Standard size: **900**
Number of poles: **8**
Fire resistance rating: **400/2**

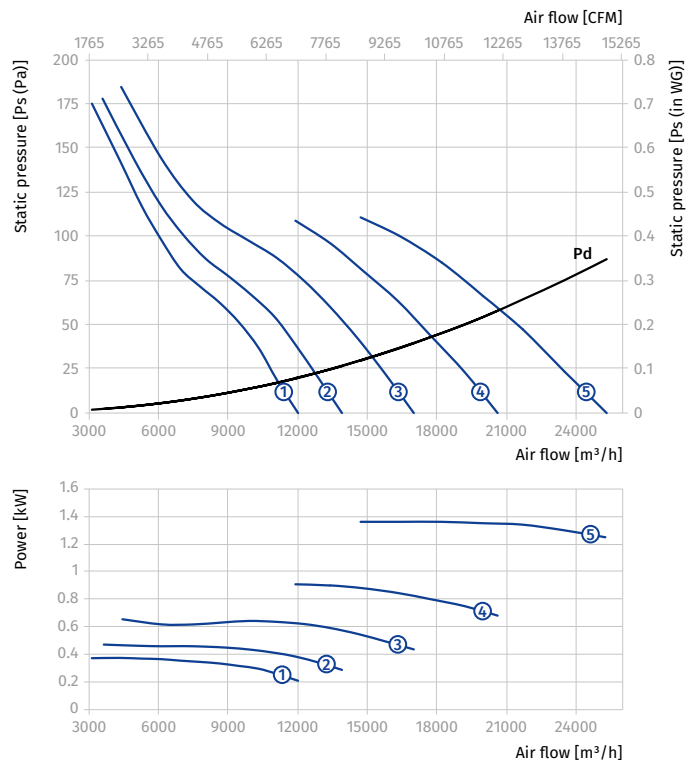

AXIS-FP 1000...400/2

Size	Number of poles	Voltage [V/50 Hz]	Fan model	Installed motor power N_y [kW]	RPM [min^{-1}]	Number of blades	Blade setting angle [°]	Weight [kg]	Length L [mm]	Curve number on graph
Axis-FP 1000-4D...400/2										
1000	4	3~400	Axis-FP 1000-4D/5.5-6/24/AL	5.5	1440	6	24	150	600	①
			Axis-FP 1000-4D/7.5-6/30/AL	7.5	1440	6	30	167	600	②
			Axis-FP 1000-4D/9.2-6/33/AL	9.2	1440	6	33	173	600	③
			Axis-FP 1000-4D/11-6/36/AL	11	1440	6	36	186	600	④
			Axis-FP 1000-4D/15-6/43/AL	15	1440	6	43	247	750	⑤
			Axis-FP 1000-4D/18.5-6/48/AL	18.5	1440	6	48	262	750	⑥
Axis-FP 1000-6D...400/2										
1000	6	3~400	Axis-FP 1000-6D/1.5-6/23/AL	1.5	960	6	23	103.5	550	①
			Axis-FP 1000-6D/2.2-6/29/AL	2.2	960	6	29	116	550	②
			Axis-FP 1000-6D/3-6/35/AL	3	960	6	35	158	600	③
			Axis-FP 1000-6D/4-6/41/AL	4	960	6	41	162	600	④
			Axis-FP 1000-6D/5.5-6/48/AL	5.5	960	6	48	175	600	⑤

Standard size: 1000
 Number of poles: 4
 Fire resistance rating: 400/2

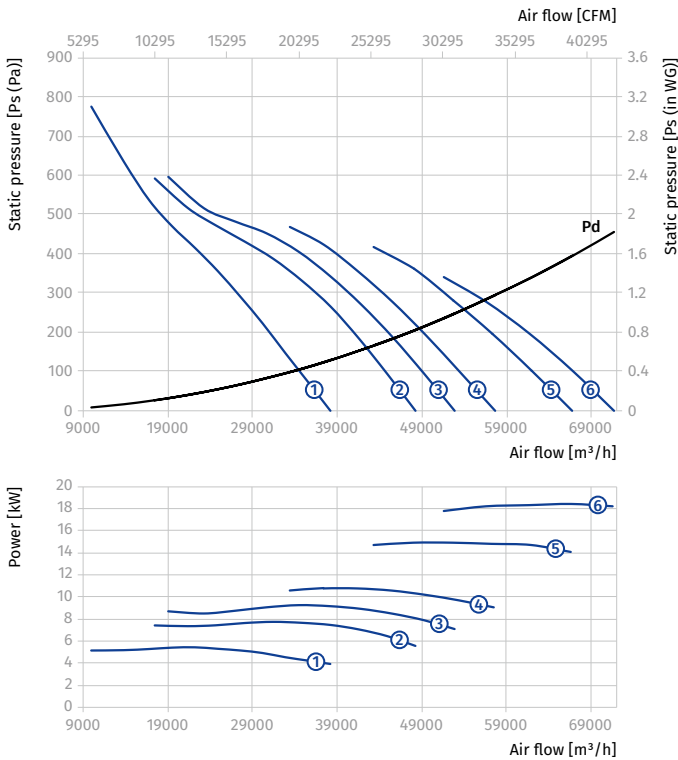

Standard size: 1000
 Number of poles: 6
 Fire resistance rating: 400/2

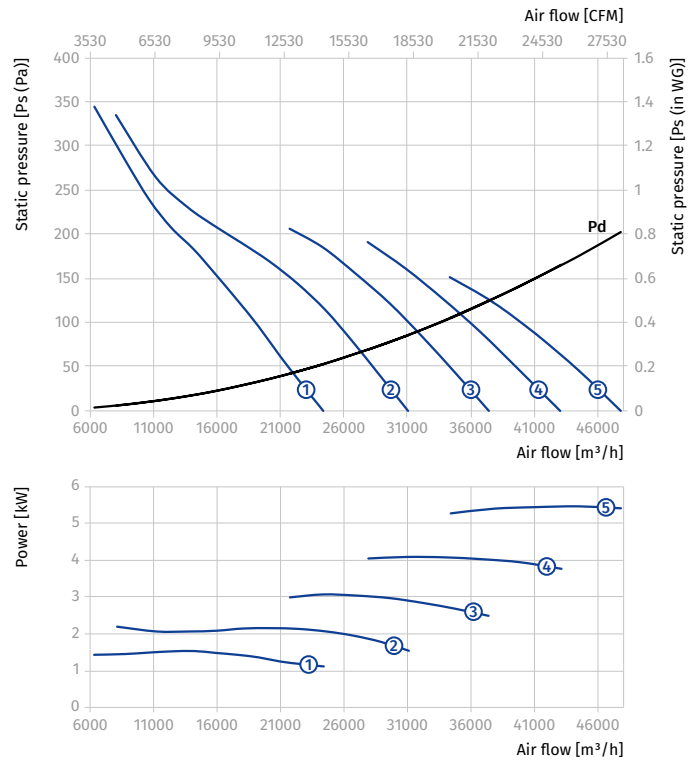

AXIS-FP 1000...400/2

Size	Number of poles	Voltage [V/50 Hz]	Fan model	Installed motor power Ny [kW]	RPM [min ⁻¹]	Number of blades	Blade setting angle [°]	Weight [kg]	Length L [mm]	Curve number on graph
Axis-FP 1000-4/6D...400/2										
1000	4/6	3~400	Axis-FP 1000-4/6D/4.5/1.5-6/20/AL	4.5/1.5	1440/960	6	20	171	600	①
			Axis-FP 1000-4/6D/6/2.2-6/25/AL	6/2.2	1440/960	6	25	182	600	②
			Axis-FP 1000-4/6D/10/3.3-6/34/AL	10/3.3	1440/960	6	34	247	750	③
			Axis-FP 1000-4/6D/14/4.5-6/41/AL	14/4.5	1440/960	6	41	262	750	④
			Axis-FP 1000-4/6D/16/6.5-6/45/AL	16/6.5	1440/960	6	45	330.5	800	⑤

Standard size: 1000
Number of poles: 4
Fire resistance rating: 400/2

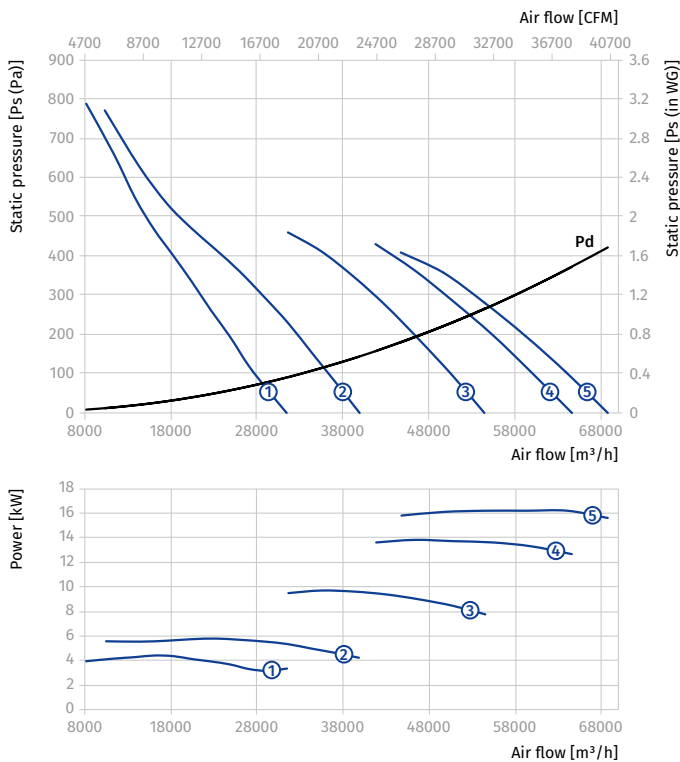

Standard size: 1000
Number of poles: 6
Fire resistance rating: 400/2

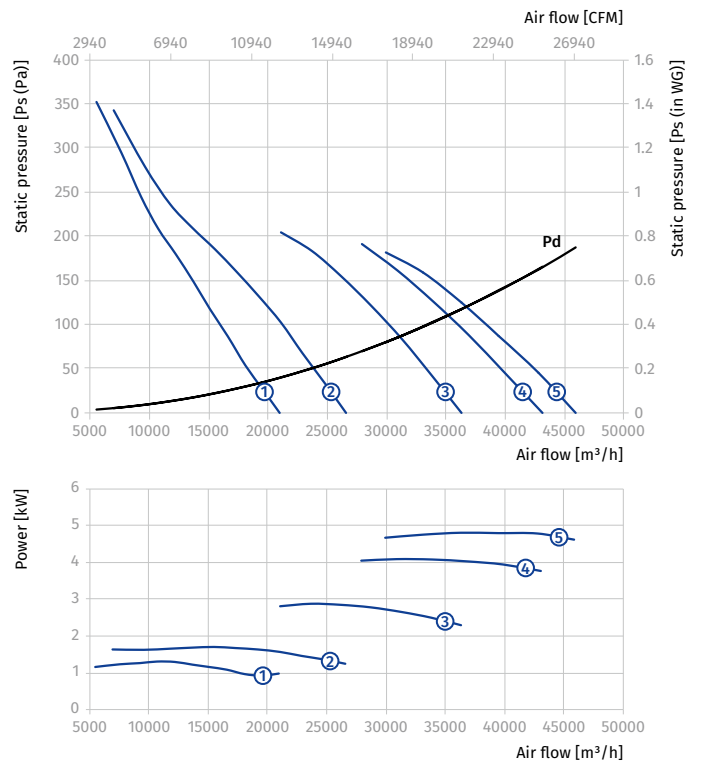

AXIS-FP 1000...400/2

Size	Number of poles	Voltage [V/50 Hz]	Fan model	Installed motor power N_y [kW]	RPM [min^{-1}]	Number of blades	Blade setting angle [°]	Weight [kg]	Length L [mm]	Curve number on graph
Axis-FP 1000-4/8D...400/2										
1000	4/8	3~400	Axis-FP 1000-4/8D/5/1.3-6/23/AL	5/1.3	1440/720	6	23	171	600	①
			Axis-FP 1000-4/8D/7.2/1.8-6/29/AL	7.2/1.8	1440/720	6	29	183	600	②
			Axis-FP 1000-4/8D/11/3-6/36/AL	11/3	1440/720	6	36	246	750	③
			Axis-FP 1000-4/8D/14/3.5-6/41/AL	14/3.5	1440/720	6	41	262	750	④
			Axis-FP 1000-4/8D/17/4.3-6/46/AL	17/4.3	1440/720	6	46	297.5	800	⑤

Standard size: 1000
 Number of poles: 4
 Fire resistance rating: 400/2

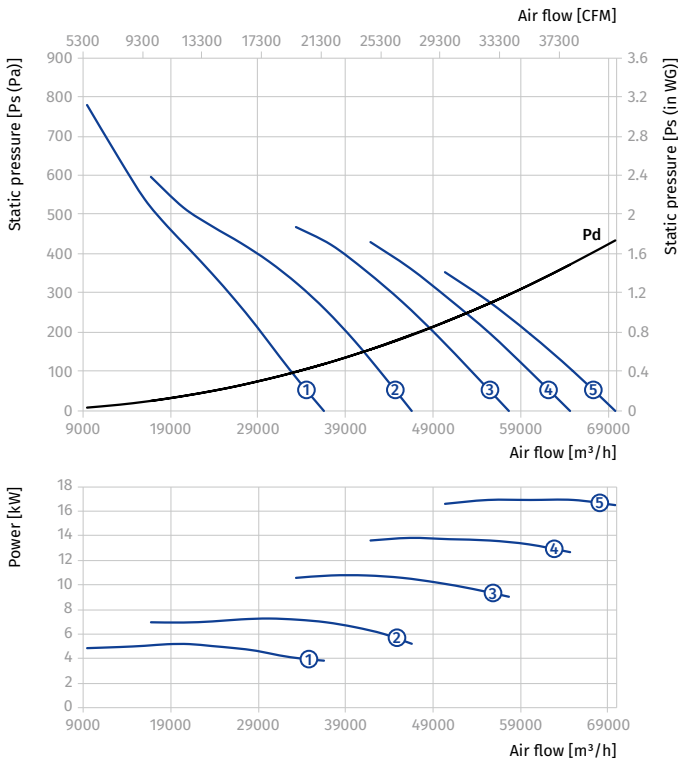

Standard size: 1000
 Number of poles: 8
 Fire resistance rating: 400/2

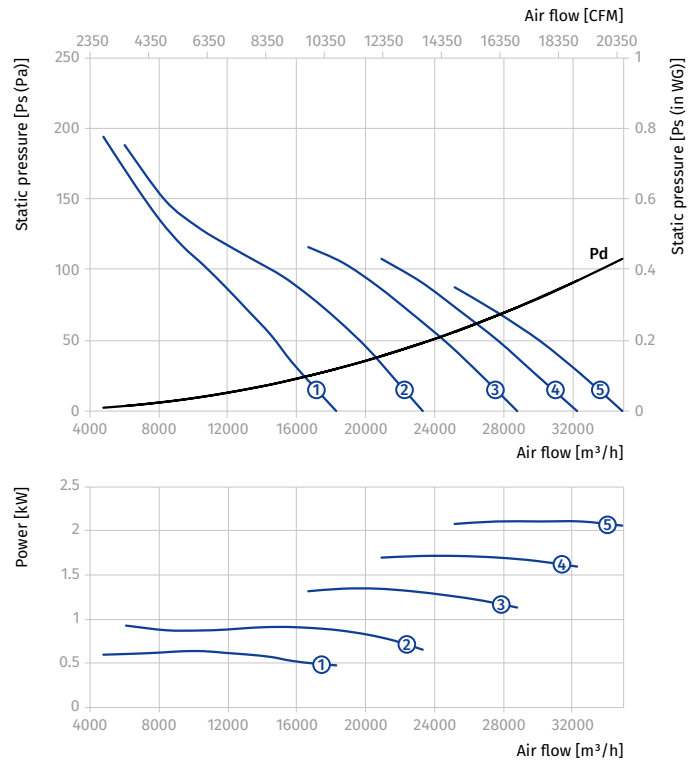

AXIS-FP 1120...400/2

Size	Number of poles	Voltage [V/50 Hz]	Fan model	Installed motor power Ny [kW]	RPM [min ⁻¹]	Number of blades	Blade setting angle [°]	Weight [kg]	Length L [mm]	Curve number on graph
Axis-FP 1120-4D...400/2										
1120	4	3~400	Axis-FP 1120-4D/7.5-6/23/AL	7.5	1440	6	23	186	600	①
			Axis-FP 1120-4D/9.2-6/27/AL	9.2	1440	6	27	191	600	②
			Axis-FP 1120-4D/11-6/31/AL	11	1440	6	31	204	600	③
			Axis-FP 1120-4D/15-6/35/AL	15	1440	6	35	299	750	④
			Axis-FP 1120-4D/18.5-6/40/AL	18.5	1440	6	40	314	750	⑤
			Axis-FP 1120-4D/22-6/43/AL	22	1440	6	43	355	800	⑥
Axis-FP 1120-6D...400/2										
1120	6	3~400	Axis-FP 1120-6D/2.2-6/23/AL	2.2	960	6	23	149	550	①
			Axis-FP 1120-6D/3-6/29/AL	3	960	6	29	176	600	②
			Axis-FP 1120-6D/4-6/34/AL	4	960	6	34	180	600	③
			Axis-FP 1120-6D/5.5-6/40/AL	5.5	960	6	40	193	600	④
			Axis-FP 1120-6D/7.5-6/46/AL	7.5	960	6	46	282	750	⑤
			Axis-FP 1120-6D/9.2-6/50/AL	9.2	960	6	50	292	750	⑥

Standard size: 1120
Number of poles: 4
Fire resistance rating: 400/2

Standard size: 1120
Number of poles: 6
Fire resistance rating: 400/2

AXIAL SMOKE EXTRACTION FANS

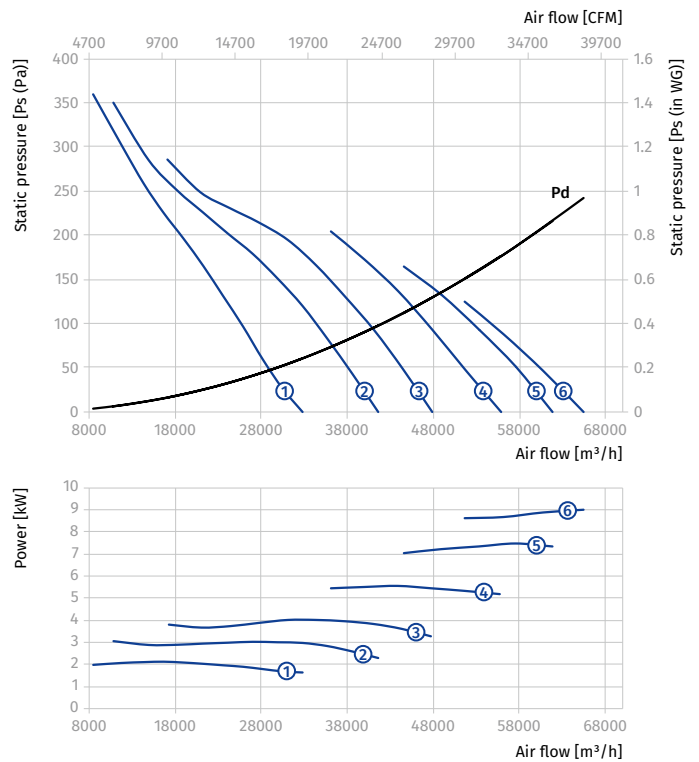
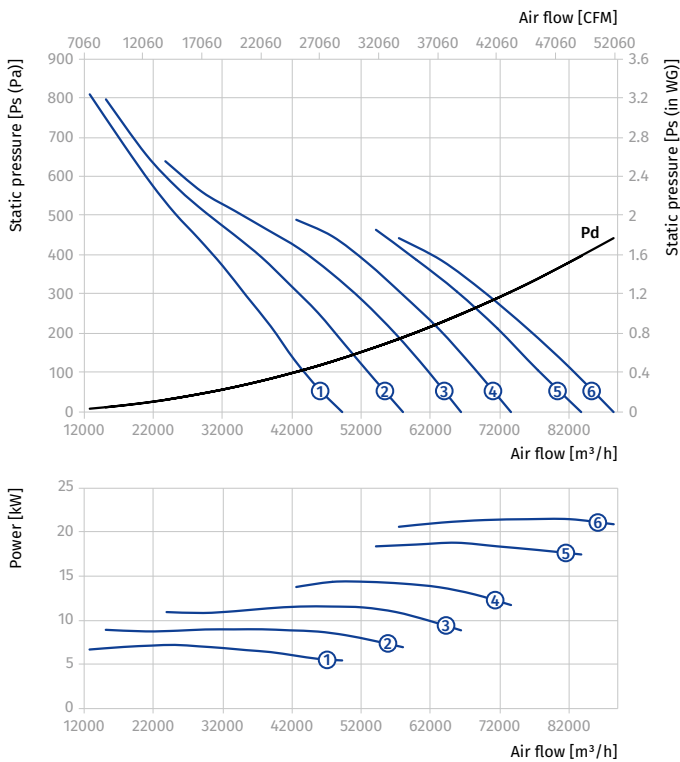

AXIS-FP 1120...400/2

Size	Number of poles	Voltage [V/50 Hz]	Fan model	Installed motor power N_y [kW]	RPM [min^{-1}]	Number of blades	Blade setting angle [°]	Weight [kg]	Length L [mm]	Curve number on graph
Axis-FP 1120-4/8D...400/2										
1120	4/6	3~400	Axis-FP 1120-4/6D/6/2.2-5/24/AL	6/2.2	1440/960	5	24	198	600	①
			Axis-FP 1120-4/6D/10/3.3-6/29/AL	10/3.3	1440/960	6	29	299	750	②
			Axis-FP 1120-4/6D/14/4.5-6/34/AL	14/4.5	1440/960	6	34	314	750	③
			Axis-FP 1120-4/6D/16/6.5-6/37/AL	16/6.5	1440/960	6	37	386	800	④
			Axis-FP 1120-4/6D/20/8.5-6/41/AL	20/8.5	1440/960	6	41	389	800	⑤

Standard size: 1120
 Number of poles: 4
 Fire resistance rating: 400/2

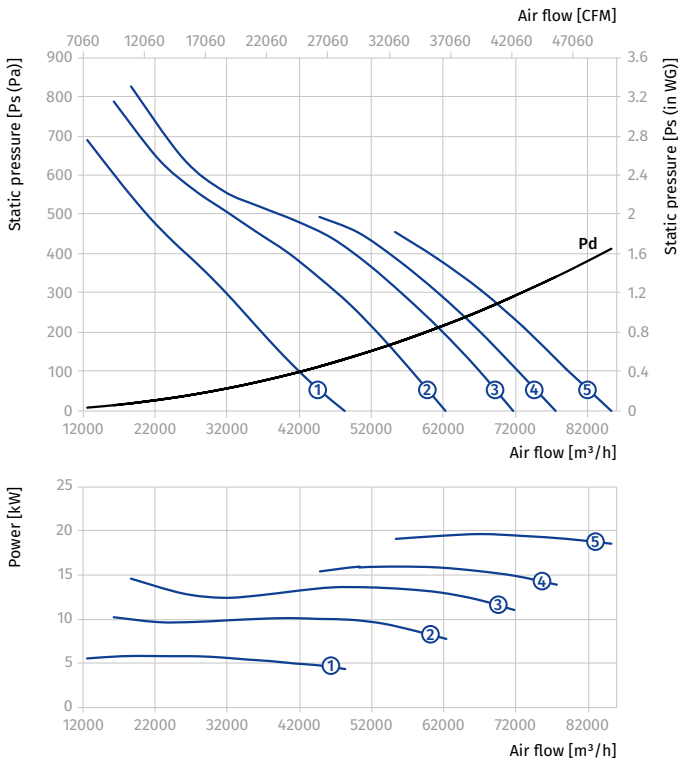

Standard size: 1120
 Number of poles: 6
 Fire resistance rating: 400/2

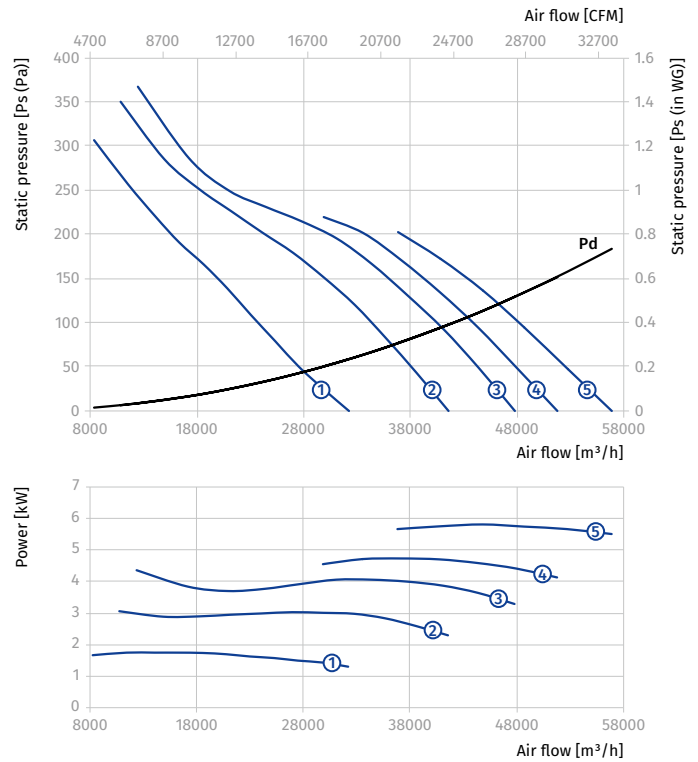

AXIAL SMOKE EXTRACTION FANS

AXIS-FP 1120...400/2

Size	Number of poles	Voltage [V/50 Hz]	Fan model	Installed motor power Ny [kW]	RPM [min ⁻¹]	Number of blades	Blade setting angle [°]	Weight [kg]	Length L [mm]	Curve number on graph
Axis-FP 1120-4/6D...400/2										
1120	4/8	3~400	Axis-FP 1120-4/8D/7.2/1.8-6/23/AL	7.2/1.8	1440/720	6	23	201	600	①
			Axis-FP 1120-4/8D/11/3-6/31/AL	11/3	1440/720	6	31	298	750	②
			Axis-FP 1120-4/8D/14/3.5-6/34/AL	14/3.5	1440/720	6	34	314	750	③
			Axis-FP 1120-4/8D/17/4.3-6/38/AL	17/4.3	1440/720	6	38	353	800	④
			Axis-FP 1120-4/8D/20/5-6/41/AL	20/5	1440/720	6	41	381	800	⑤

Standard size: 1120
Number of poles: 4
Fire resistance rating: 400/2

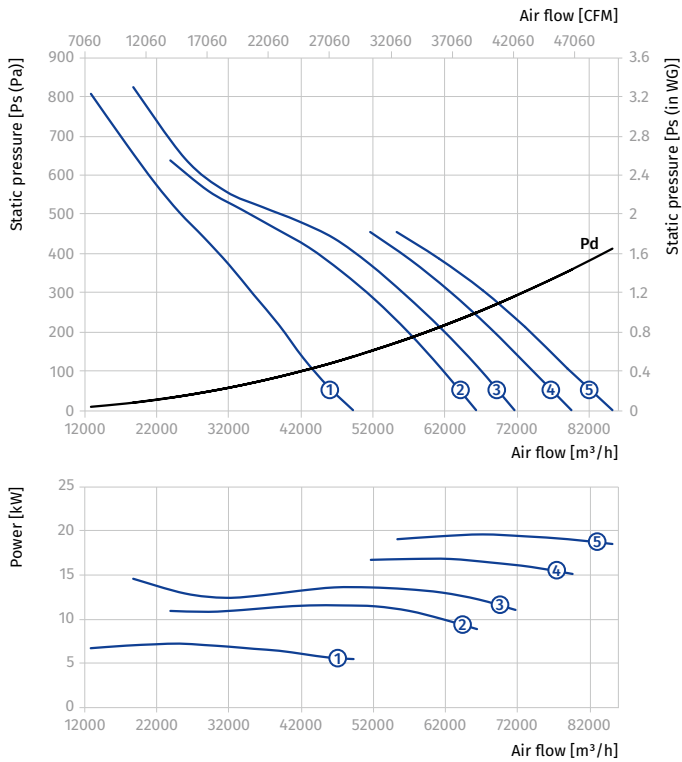

Standard size: 1120
Number of poles: 8
Fire resistance rating: 400/2

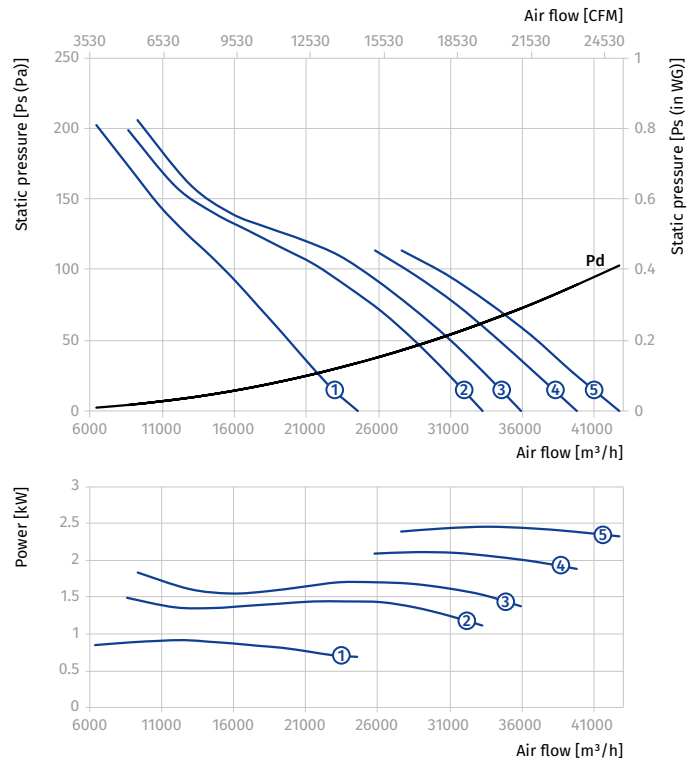

AXIAL SMOKE EXTRACTION FANS

AXIS-FP 1250...400/2

Size	Number of poles	Voltage [V/50 Hz]	Fan model	Installed motor power N_y [kW]	RPM [min^{-1}]	Number of blades	Blade setting angle [°]	Weight [kg]	Length L [mm]	Curve number on graph
Axis-FP 1250-4D...400/2										
1250	4	3~400	Axis-FP 1250-4D/18.5-8/23/AL	18.5	1440	8	23	340	750	①
			Axis-FP 1250-4D/22-8/28/AL	22	1440	8	28	382	800	②
			Axis-FP 1250-4D/30-8/34/AL	30	1440	8	34	408	800	③
Axis-FP 1250-6D...400/2										
1250	6	3~400	Axis-FP 1250-6D/5.5-8/23/AL	5.5	960	8	23	236	600	①
			Axis-FP 1250-6D/7.5-8/30/AL	7.5	960	8	30	308	750	②
			Axis-FP 1250-6D/9.2-8/34/AL	9.2	960	8	34	318	750	③
			Axis-FP 1250-6D/11-8/38/AL	11	960	8	38	332	750	④

Standard size: 1250
 Number of poles: 4
 Fire resistance rating: 400/2

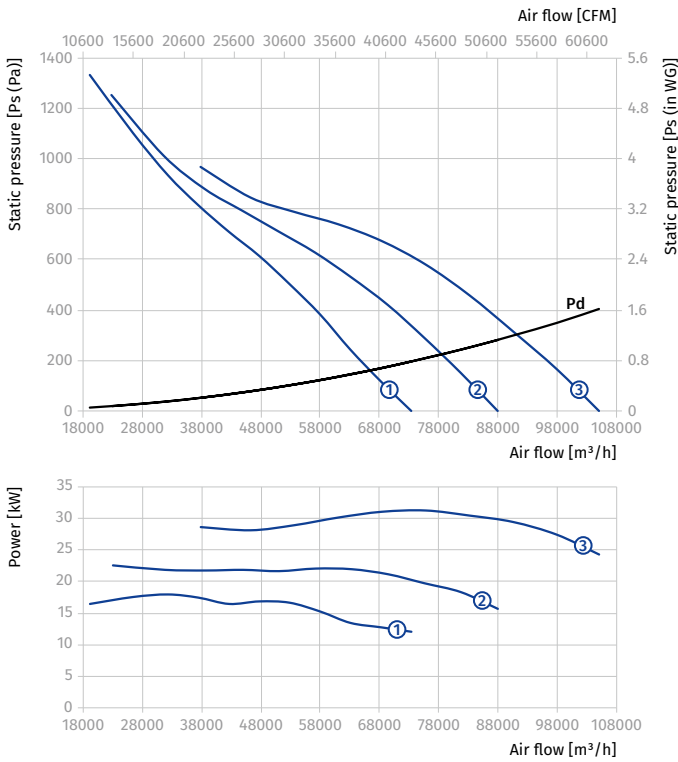

Standard size: 1250
 Number of poles: 6
 Fire resistance rating: 400/2

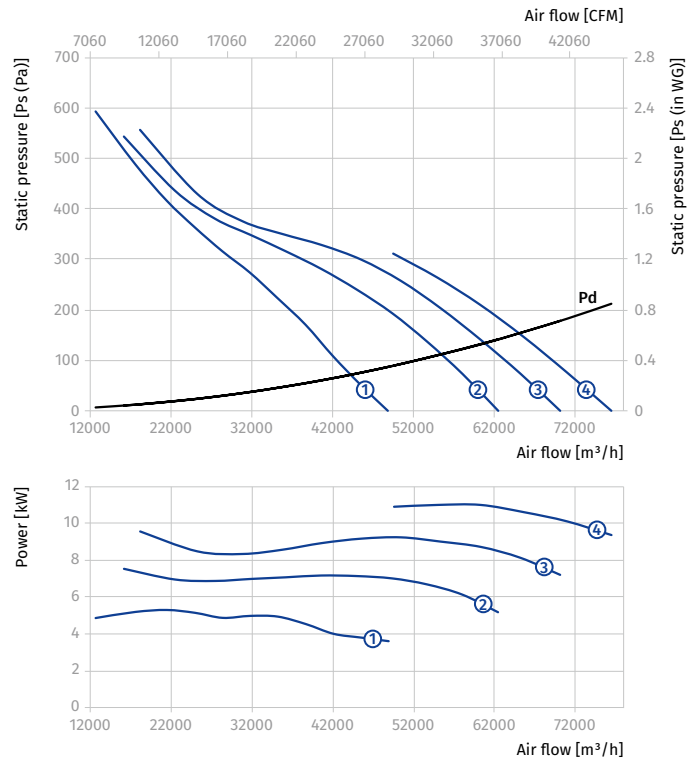

AXIS-FP 1250...400/2

Size	Number of poles	Voltage [V/50 Hz]	Fan model	Installed motor power Ny [kW]	RPM [min ⁻¹]	Number of blades	Blade setting angle [°]	Weight [kg]	Length L [mm]	Curve number on graph
Axis-FP 1250-4/6D...400/2										
1250	4/6	3~400	Axis-FP 1250-4/6D/16/6.5-8/20/AL	16/6.5	1440/960	8	20	413.2	800	①
			Axis-FP 1250-4/6D/20/8.5-8/25/AL	20/8.5	1440/960	8	25	416	800	②
			Axis-FP 1250-4/6D/26/9-8/31/AL	26/9	1440/960	8	31	514	850	③

Standard size: 1250
Number of poles: 4
Fire resistance rating: 400/2

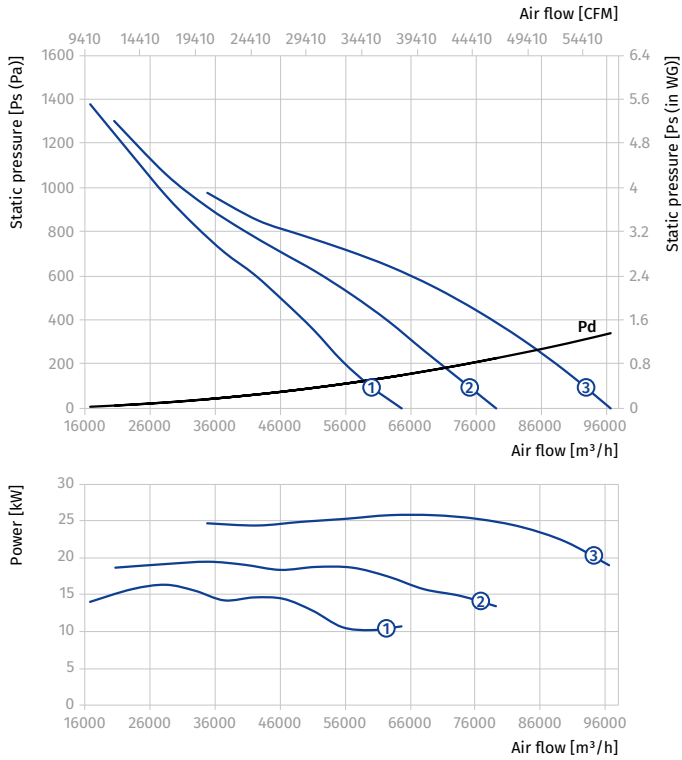

Standard size: 1250
Number of poles: 6
Fire resistance rating: 400/2

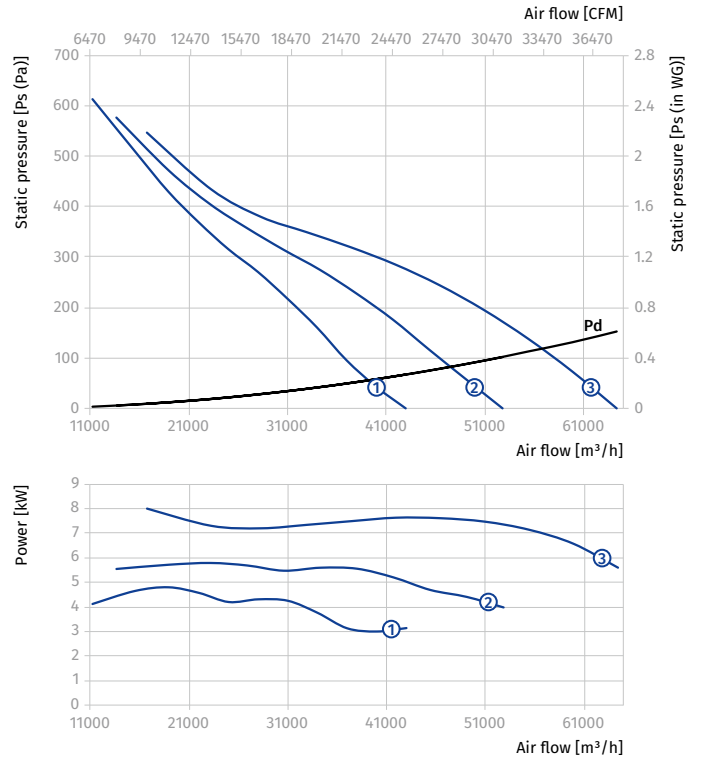

AXIS-FP 1250...400/2

Size	Number of poles	Voltage [V/50 Hz]	Fan model	Installed motor power N_y [kW]	RPM [min^{-1}]	Number of blades	Blade setting angle [°]	Weight [kg]	Length L [mm]	Curve number on graph
Axis-FP 1250-4/8D...400/2										
1250	4/8	3~400	Axis-FP 1250-4/8D/17/4.3-8/21/AL	17/4.3	1440/720	8	21	380	800	①
			Axis-FP 1250-4/8D/20/5-8/25/AL	20/5	1440/720	8	25	408	800	②
			Axis-FP 1250-4/8D/28/6.5-8/32/AL	28/6.5	1440/720	8	32	469	850	③



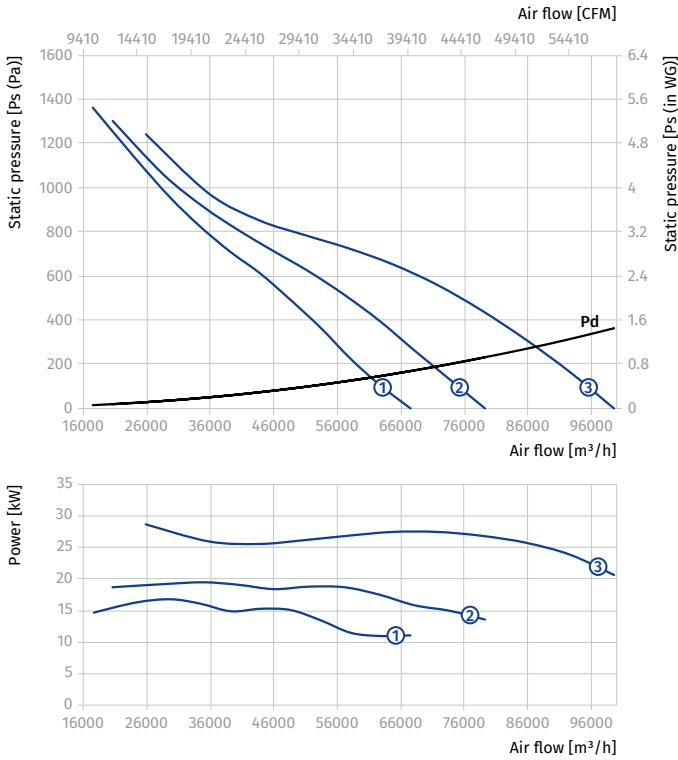



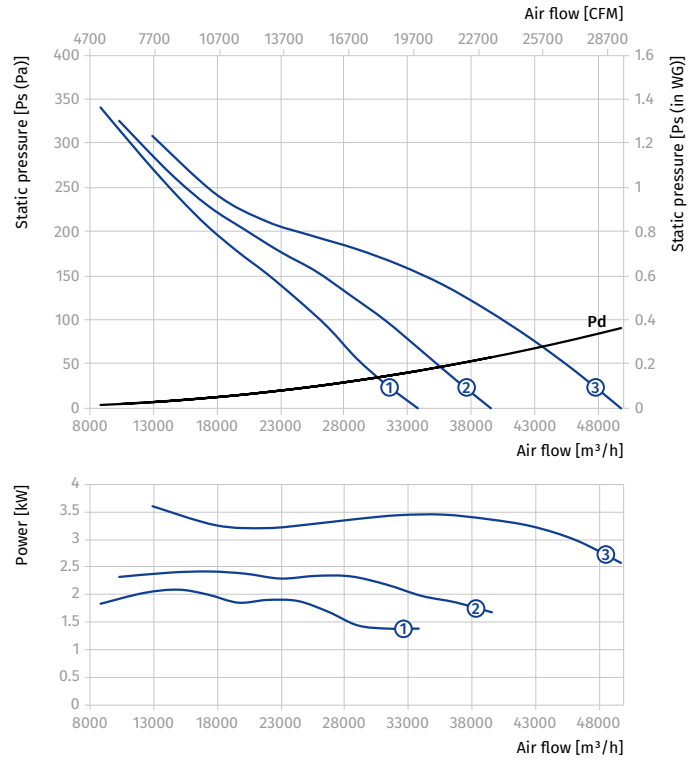

Standard size: 1250
 Number of poles: 4
 Fire resistance rating: 400/2



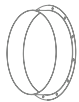
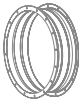

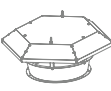
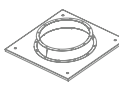
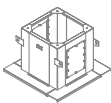
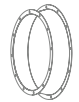

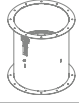
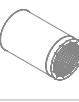
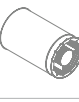
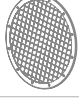
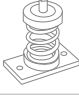





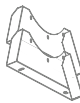
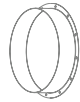

Standard size: 1250
 Number of poles: 8
 Fire resistance rating: 400/2

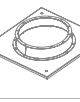
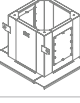
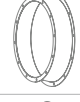

Fan accessories selection table

Fan		Ø 400	Ø 450	Ø 500	Ø 560	Ø 630
Carrier		O-AF-400	O-AF-450	O-AF-500	O-AF-560	O-AF-630
Flange		F-AF-400	F-AF-450	F-AF-500	F-AF-560	F-AF-630
Flexible joint		EVAF-AF-400	EVAF-AF-450	EVAF-AF-500	EVAF-AF-560	EVAF-AF-630
Fire-resistant flexible joint (up to 400 °C)		EVAF-AF-400-400/2	EVAF-AF-450-400/2	EVAF-AF-500-400/2	EVAF-AF-560-400/2	EVAF-AF-630-400/2
Hood		Z-AF-400	Z-AF-450	Z-AF-500	Z-AF-560	Z-AF-630
Roof adapter		PK-AF-400	PK-AF-450	PK-AF-500	PK-AF-560	PK-AF-630
Mounting curb		SM-AF 400-450	SM-AF 400-450	SM-AF 500	SM-AF 560-630	SM-AF 560-630
Inlet cone		VK-AF-400	VK-AF-450	VK-AF-500	VK-AF-560	VK-AF-630
Backdraft damper		VRV-AF-400	VRV-AF-450	VRV-AF-500	VRV-AF-560	VRV-AF-630
Fire-resistant backdraft damper (up to 400 °C)		VRV-AF-400-400/2	VRV-AF-450-400/2	VRV-AF-500-400/2	VRV-AF-560-400/2	VRV-AF-630-400/2
Backdraft damper		VRV1-AF-400	VRV1-AF-450	VRV1-AF-500	VRV1-AF-560	VRV1-AF-630
Silencer SD		SD-400-1D	SD-450-1D	SD-500-1D	SD-560-1D	SD-630-1D
		SD-400-1.5D	SD-450-1.5D	SD-500-1.5D	SD-560-1.5D	SD-630-1.5D
		SD-400-2D	SD-450-2D	SD-500-2D	SD-560-2D	SD-630-2D
Silencer SDV		SDV-400-1D	SDV-450-1D	SDV-500-1D	SDV-560-1D	SDV-630-1D
		SDV-400-1.5D	SDV-450-1.5D	SDV-500-1.5D	SDV-560-1.5D	SDV-630-1.5D
		SDV-400-2D	SDV-450-2D	SDV-500-2D	SDV-560-2D	SDV-630-2D
Protective mesh		SZ-AF-400	SZ-AF-450	SZ-AF-500	SZ-AF-560	SZ-AF-630
Antivibration mount		SIF-AF*	SIF-AF*	SIF-AF*	SIF-AF*	SIF-AF*
Antivibration mount		SIG-AF*	SIG-AF*	SIG-AF*	SIG-AF*	SIG-AF*

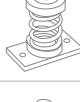
* selection according to the fan weight

Fan		Ø 710	Ø 800	Ø 900	Ø 1000	Ø 1120	Ø 1250
Carrier		O-AF-710	O-AF-800	O-AF-900	O-AF-1000	O-AF-1120	O-AF-1250
Flange		F-AF-710	F-AF-800	F-AF-900	F-AF-1000	F-AF-1120	F-AF-1250
Flexible joint		EVAF-AF-710	EVAF-AF-800	EVAF-AF-900	EVAF-AF-1000	EVAF-AF-1120	EVAF-AF-1250
Fire-resistant flexible joint (up to 400 °C)		EVAF-AF-710-400/2	EVAF-AF-800-400/2	EVAF-AF-900-400/2	EVAF-AF-1000-400/2	EVAF-AF-1120-400/2	EVAF-AF-1250-400/2
Hood		Z-AF-710	Z-AF-800	Z-AF-900	Z-AF-1000	Z-AF-1120	Z-AF-1250
Roof adapter		PK-AF-710	PK-AF-800	PK-AF-900	PK-AF-1000	PK-AF-1120	PK-AF-1250
Mounting curb		SM-AF 710-800	SM-AF 710-800	SM-AF 900	SM-AF 1000-1120	SM-AF 1000-1120	SM-AF 1250
Inlet cone		VK-AF-710	VK-AF-800	VK-AF-900	VK-AF-1000	VK-AF-1120	VK-AF-1250
Backdraft damper		VRV-AF-710	VRV-AF-800	VRV-AF-900	VRV-AF-1000	VRV-AF-1120	VRV-AF-1250
Fire-resistant backdraft damper (up to 400 °C)		VRV-AF-710-400/2	VRV-AF-800-400/2	VRV-AF-900-400/2	VRV-AF-1000-400/2	VRV-AF-1120-400/2	VRV-AF-1250-400/2
Backdraft damper		VRV1-AF-710	VRV1-AF-800	VRV1-AF-900	VRV1-AF-1000	VRV1-AF-1120	VRV1-AF-1250
Silencer SD		SD-710-1D	SD-800-1D	SD-900-1D	SD-1000-1D	SD-1120-1D	SD-1250-1D
		SD-710-1.5D	SD-800-1.5D	SD-900-1.5D	SD-1000-1.5D	SD-1120-1.5D	SD-1250-1.5D
		SD-710-2D	SD-800-2D	SD-900-2D	SD-1000-2D	SD-1120-2D	SD-1120-2D
Silencer SDV		SDV-710-1D	SDV-800-1D	SDV-900-1D	SDV-1000-1D	SDV-1120-1D	SDV-1250-1D
		SDV-710-1.5D	SDV-800-1.5D	SDV-900-1.5D	SDV-1000-1.5D	SDV-1120-1.5D	SDV-1250-1.5D
		SDV-710-2D	SDV-800-2D	SDV-900-2D	SDV-1000-2D	SDV-1120-2D	SDV-1120-2D
Protective mesh		SZ-AF-710	SZ-AF-800	SZ-AF-900	SZ-AF-1000	SZ-AF-1120	SZ-AF-1250
Antivibration mount		SIF-AF*	SIF-AF*	SIF-AF*	SIF-AF*	SIF-AF*	SIF-AF*
Antivibration mount		SIG-AF*	SIG-AF*	SIG-AF*	SIG-AF*	SIG-AF*	SIG-AF*

* selection according to the fan weight

CARRIER O-AF

- Used for mounting the fans to the floor, walls or ceiling.
- Made of steel with a polymer coating.
- Number of carriers required to complete one fan: 1 pc. (one carrier consists of two brackets).

Model	Dimensions [mm]								Weight [kg]
	A	B	H	M	a	R	Ød	n	
O-AF-400	510	395	115	45	160	225	8	4	1.15
O-AF-450	560	435	125	45	180	250	8	4	1.3
O-AF-500	610	480	130	45	200	280	12	4	1.4
O-AF-560	670	525	140	45	230	310	12	4	1.6
O-AF-630	740	575	150	45	255	345	12	4	1.8
O-AF-710	820	630	160	45	280	385	12	5	2.0
O-AF-800	910	705	180	45	315	430	12	5	2.35
O-AF-900	1020	795	215	52	360	485	15	5	6.3
O-AF-1000	1120	875	235	52	400	535	15	5	7.2
O-AF-1120	1240	1002	270	52	460	595	15	6	9.1
O-AF-1250	1370	1087	285	52	510	660	15	6	10.25

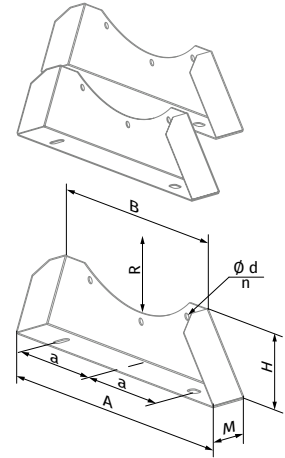

FLANGE F-AF

- Enables attaching round ducts of appropriate size to the fan.
- Made of steel with a polymer coating.

Model	Dimensions [mm]					Weight [kg]
	ØD	ØD1	ØD2	Ød	n	
F-AF-400	400	450	490	8	12	2.26
F-AF-450	450	500	540	8	12	2.53
F-AF-500	500	560	600	12	12	2.9
F-AF-560	560	620	660	12	12	3.24
F-AF-630	630	690	730	12	12	3.63
F-AF-710	710	770	810	12	16	4.08
F-AF-800	800	860	900	12	16	4.58
F-AF-900	900	970	1015	15	16	5.41
F-AF-1000	1000	1070	1115	15	16	6.0
F-AF-1120	1120	1190	1270	15	20	7.51
F-AF-1250	1250	1320	1400	15	20	8.36

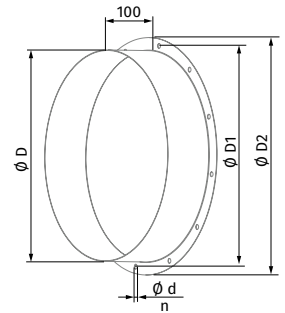

FLEXIBLE JOINT EVAF-AF

FIRE-RESISTANT FLEXIBLE JOINT EVAF-AF...400/2

- Flexible joints cancel out any potential vibrations transmitted by the fans or air handling units to the air ducting as well as partially compensate for the air duct assembly deformations caused by temperature variation.
- The flexible joints are formed by two flanges joined with vibration-cancelling material and are made of polymer-coated steel and PVC tape reinforced with polyamide fabric. The joints are not intended to withstand any significant mechanical loads and, therefore, may not be used as load-bearing structures.
- The **EVAF-AF...400/2** joints are designed for operation at a temperature of 400 °C for 2 hours.

Model		Dimensions [mm]					Weight [kg]
		ØD	ØD1	ØD2	Ød	n	
EVAF-AF-400	EVAF-AF-400-400/2	400	450	490	8	12	4.76
EVAF-AF-450	EVAF-AF-450-400/2	450	500	540	8	12	5.34
EVAF-AF-500	EVAF-AF-500-400/2	500	560	600	12	12	6.12
EVAF-AF-560	EVAF-AF-560-400/2	560	620	660	12	12	6.83
EVAF-AF-630	EVAF-AF-630-400/2	630	690	730	12	12	7.66
EVAF-AF-710	EVAF-AF-710-400/2	710	770	810	12	16	8.6
EVAF-AF-800	EVAF-AF-800-400/2	800	860	900	12	16	9.67
EVAF-AF-900	EVAF-AF-900-400/2	900	970	1015	15	16	11.4
EVAF-AF-1000	EVAF-AF-1000-400/2	1000	1070	1115	15	16	12.64
EVAF-AF-1120	EVAF-AF-1120-400/2	1120	1190	1270	15	20	15.73
EVAF-AF-1250	EVAF-AF-1250-400/2	1250	1320	1400	15	20	17.52

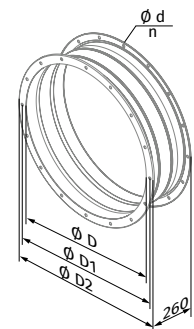

HOOD Z-AF

- o Ensures trouble-free operation of fans on rooftops.
- o Made of steel with a polymer coating.

Model	Dimensions [mm]									Weight [kg]
	ØD	ØD1	ØD2	Ød	n	H	H1	A	B	
Z-AF-400	400	450	490	8	12	265	301	672	774	10.15
Z-AF-450	450	500	540	8	12	280	326	742	855	12.23
Z-AF-500	500	560	600	12	12	320	367	790	910	13.88
Z-AF-560	560	620	660	12	12	335	382	860	991	15.95
Z-AF-630	630	690	730	12	12	360	406	988	1139	27.25
Z-AF-710	710	770	810	12	16	420	466	1072	1236	36.54
Z-AF-800	800	860	900	12	16	478	536	1190	1371	47.42
Z-AF-900	900	970	1015	15	16	527	582	1346	1551	69.09
Z-AF-1000	1000	1070	1115	15	16	655	710	1552	1789	99.81
Z-AF-1120	1120	1190	1270	15	20	670	725	1707	1968	118
Z-AF-1250	1250	1320	1400	15	20	700	755	1845	2128	136

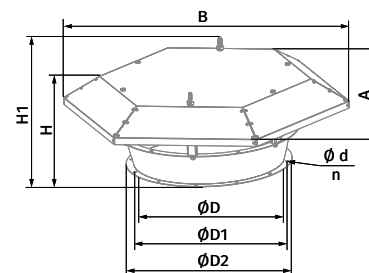

ROOF ADAPTER PK-AF

- o Used for mounting **Axis-P** on rooftops.
- o Made of steel with a polymer coating.

Model	Dimensions [mm]													Weight [kg]
	ØD	ØD1	ØD2	Ød	n	ØF	ØF1	ØF2	Ød1	n1	A	B	H	
PK-AF-400	400	450	490	8	12	450	500	540	8	12	580	701	115	7.2
PK-AF-450	450	500	540	8	12	500	560	600	12	12	580	701	130	7.5
PK-AF-500	500	560	600	12	12	560	620	660	12	12	640	770	140	10.3
PK-AF-560	560	620	660	12	12	630	690	730	12	12	750	920	155	14.2
PK-AF-630	630	690	730	12	12	710	770	810	12	16	750	920	170	15.1
PK-AF-710	710	770	810	12	16	800	860	900	12	16	980	1150	210	27.7
PK-AF-800	800	860	900	12	16	900	970	1015	15	16	980	1150	230	28.7
PK-AF-900	900	970	1015	15	16	1000	1070	1115	15	16	1050	1220	250	41.7
PK-AF-1000	1000	1070	1115	15	16	1120	1190	1270	15	20	1340	1510	280	72.5
PK-AF-1120	1120	1190	1270	15	20	1250	1320	1400	15	20	1340	1510	295	75.1
PK-AF-1250	1250	1320	1400	15	20	1400	1470	1550	15	20	1500	1700	325	91

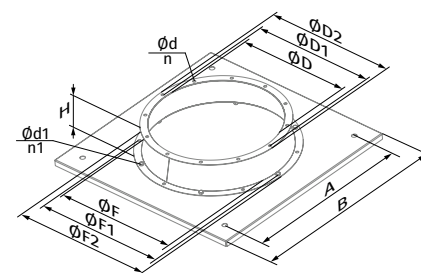

MOUNTING CURB SM-AF

- o Designed to enable fan installation on rooftops.
- o Made of steel with a polymer coating. The outer frames are supported for installation on the roof. The mounting curb is equipped with a side inspection door.

Model	Dimensions [mm]				Weight [kg]
	H	A	B	C	
SM-AF-400-450	600	580	692	979	50.1
SM-AF-500	600	640	760	1047	53.7
SM-AF-560-630	600	750	910	1197	61.8
SM-AF-710-800	600	980	1140	1427	74.2
SM-AF-900	650	1050	1208	1495	81.3
SM-AF-1000-1120	750	1340	1498	1784	129.4
SM-AF-1250	750	1500	1688	1974	143.1

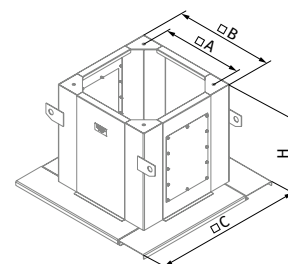

INLET CONE VK-AF

- The inlet cone is recommended to be installed upstream of the fan to improve the air flow parameters. However, it must be installed in the absence of ducting attached to the fan inlet. The inlet cone helps reduce the fan dynamic pressure and increase the static component of the total fan pressure. The unit can be used in combination with the **SZ-AF** protective mesh which must be one size larger than the unit.
- The unit has two flanges and is made of steel with a polymer coating.

Model	Dimensions [mm]										Weight [kg]	
	ØD	ØD1	ØD2	Ød	n	ØF	ØF1	ØF2	H	Ød1		n
VK-AF-400	400	450	490	8	12	450	500	540	95	8	12	2.7
VK-AF-450	450	500	540	8	12	500	560	600	110	12	12	3.3
VK-AF-500	500	560	600	12	12	560	620	660	120	12	12	4.0
VK-AF-560	560	620	660	12	12	630	690	730	135	12	12	4.65
VK-AF-630	630	690	730	12	12	710	770	810	150	12	16	6.8
VK-AF-710	710	770	810	12	16	800	860	900	170	12	16	12
VK-AF-800	800	860	900	12	16	900	970	1015	190	15	16	15
VK-AF-900	900	970	1015	15	16	1000	1070	1115	210	15	16	21
VK-AF-1000	1000	1070	1115	15	16	1120	1190	1270	240	15	20	36.7
VK-AF-1120	1120	1190	1270	15	20	1250	1320	1400	255	15	20	45
VK-AF-1250	1250	1320	1400	15	20	1400	1470	1550	285	15	20	53.5

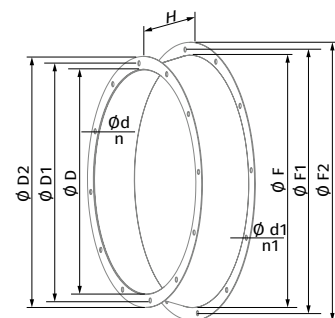

BACKDRAFT DAMPER VRV-AF FIRE-RESISTANT BACKDRAFT DAMPER VRV-AF...400/2

- The backdraft damper with spring-loaded blades is used for shutoff of air flow in the air ducts and prevention of air backdraft during standstill of ventilation equipment. The damper blades are opened with the air pressure and closed with the spring.
- The damper placement in a ventilation system should account for the air flow direction. In case of a horizontal installation of the damper, the pivot axis of the blades must be true horizontal. A vertically installed damper is only suitable for air extraction duty. To assemble the **Axis-FP** fans, use the **VRV-AF...400/2** dampers, which are designed to operate at a temperature of 400 °C for 2 hours.
- The unit casing and the two spring-loaded blades are made of polymer-coated steel.

Model	Dimensions [mm]						Weight [kg]	
	ØD	ØD1	ØD2	Ød	n	L		
VRV-AF-400	VRV-AF-400-400/2	400	450	490	8	12	250	5.4
VRV-AF-450	VRV-AF-450-400/2	450	500	540	8	12	250	6.2
VRV-AF-500	VRV-AF-500-400/2	500	560	590	12	12	250	7.1
VRV-AF-560	VRV-AF-560-400/2	560	620	650	12	12	320	9.6
VRV-AF-630	VRV-AF-630-400/2	630	690	720	12	12	370	14.2
VRV-AF-710	VRV-AF-710-400/2	710	770	810	12	16	390	21.4
VRV-AF-800	VRV-AF-800-400/2	800	860	900	12	16	390	25.4
VRV-AF-900	VRV-AF-900-400/2	900	970	1010	15	16	450	32.6
VRV-AF-1000	VRV-AF-1000-400/2	1000	1070	1110	15	16	450	36.9
VRV-AF-1120	VRV-AF-1120-400/2	1120	1190	1260	15	20	540	59.5
VRV-AF-1250	VRV-AF-1250-400/2	1250	1320	1390	15	20	540	67.4

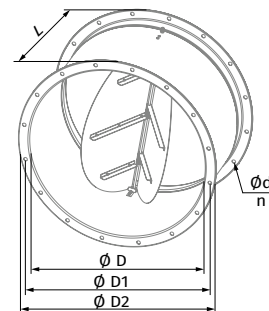

BACKDRAFT DAMPER VRV1-AF

- The backdraft damper with a gravity plate is used for supply pressurisation systems and designed for shutoff of air flow during standstill of ventilation equipment. The damper plate opens with the pressure created by the air flow and closes under its own weight, blocking the duct.
- The **VRV1-AF** damper is only suitable for air supply duty and must be installed in the vertical position.
- The damper is made from polymer coated steel and has a single blade which closes under its own weight.

Model	Dimensions [mm]					Weight [kg]
	ØD	ØD1	ØD2	Ød	n	
VRV1-AF-400	400	450	490	8	12	8.1
VRV1-AF-450	450	500	540	8	12	9.8
VRV1-AF-500	500	560	600	12	12	14.4
VRV1-AF-560	560	620	660	12	12	17.5
VRV1-AF-630	630	690	730	12	12	21.4
VRV1-AF-710	710	770	810	12	16	26.8
VRV1-AF-800	800	860	900	12	16	33.2
VRV1-AF-900	900	970	1015	15	16	53.7
VRV1-AF-1000	1000	1070	1115	15	16	65
VRV1-AF-1120	1120	1190	1270	15	20	82.1
VRV1-AF-1250	1250	1320	1400	15	20	100.3

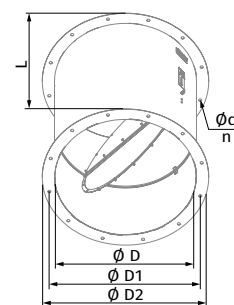

SILENCER SD

- o The silencer is used for attenuation of the operation noise generated by ventilation equipment and spreaded in the the air ducts. Designed for connection to round air ducts.
- o The **SD** silencer has a polymer-coated steel casing filled with noncombustible material that has a protective coating to prevent fiber deformation.

Model			Dimensions [mm]							Weight [kg]			
			ØD	ØD1	ØD2	L (1D)	L (1.5D)	L (2D)	Md	n	(1D)	(1.5D)	(2D)
SD-400-1D	SD-400-1.5D	SD-400-2D	400	450	515	402	602	802	M6	12	9.5	13.1	16.7
SD-450-1D	SD-450-1.5D	SD-450-2D	450	500	565	452	677	902	M6	12	11.6	16.2	20.8
SD-500-1D	SD-500-1.5D	SD-500-2D	500	560	615	502	752	1002	M10	12	13.9	19.5	25.4
SD-560-1D	SD-560-1.5D	SD-560-2D	560	620	675	562	842	1122	M10	12	17.2	24.5	31.5
SD-630-1D	SD-630-1.5D	SD-630-2D	630	690	745	632	947	1262	M10	12	20.5	29.3	38.1
SD-710-1D	SD-710-1.5D	SD-710-2D	710	770	825	712	1067	1422	M10	16	25.6	36.2	47.6
SD-800-1D	SD-800-1.5D	SD-800-2D	800	860	903	801	1202	1601	M10	16	32.3	46.3	65.2
SD-900-1D	SD-900-1.5D	SD-900-2D	900	970	1003	901	1382	1801	M10	16	40.2	57.8	80.4
SD-1000-1D	SD-1000-1.5D	SD-1000-2D	1000	1070	1120	1002	1502	2002	M10	16	54.4	79.0	109.0
SD-1120-1D	SD-1120-1.5D	SD-1120-2D	1120	1190	1273	1122	1682	2242	M12	20	70.2	101.0	141.4
SD-1250-1D	SD-1250-1.5D	SD-1250-2D	1250	1320	1410	1252	1877	2502	M12	20	86.3	124.8	172.6

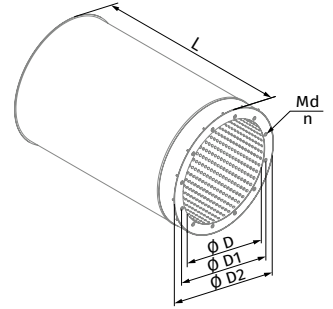

Noise level reduction

- o The values shown in the tables represent the difference between the sound power level (Lw) of the combination of the fan, the attenuator and the power of one fan.
- o To determine the sound power level of the fan equipped with a silencer, the insertion loss must be subtracted from the rated sound power level (Lw) of the fan on the mid-frequency spectrum in the octave band given in the fan specifications.

Model	Sound attenuation by frequency band [dB]								LwA [dBA] Sound-power level, A-weighted
	63 Hz	125 Hz	250 Hz	500 Hz	1000 Hz	2000 Hz	4000 Hz	8000 Hz	
SD-400-1D	2	3	5	9	13	10	8	7	17
SD-450-1D	2	3	5	10	13	10	8	7	17
SD-500-1D	2	3	6	10	14	10	8	7	17
SD-560-1D	2	4	6	10	14	10	8	7	17
SD-630-1D	3	4	7	13	14	9	8	6	18
SD-710-1D	3	4	8	14	14	9	7	6	18
SD-800-1D	3	4	8	14	13	9	7	6	17
SD-900-1D	3	4	9	14	13	8	7	6	17
SD-1000-1D	3	4	9	14	12	8	7	6	17
SD-1120-1D	3	4	10	14	12	8	6	6	17
SD-1250-1D	3	4	10	14	12	8	6	6	17

Model	Sound attenuation by frequency band [dB]								LwA [dBA] Sound-power level, A-weighted
	63 Hz	125 Hz	250 Hz	500 Hz	1000 Hz	2000 Hz	4000 Hz	8000 Hz	
SD-400-1.5D	3	5	8	13	17	14	12	10	21
SD-450-1.5D	3	5	8	14	17	14	12	10	21
SD-500-1.5D	3	5	8	14	18	14	12	10	21
SD-560-1.5D	4	6	9	14	18	14	12	10	21
SD-630-1.5D	4	6	9	17	19	13	12	8	22
SD-710-1.5D	4	6	10	18	19	13	11	8	22
SD-800-1.5D	4	6	10	18	18	13	11	8	21
SD-900-1.5D	4	6	11	18	16	11	10	8	20
SD-1000-1.5D	5	6	11	18	16	11	10	8	20
SD-1120-1.5D	5	6	12	18	15	11	9	9	20
SD-1250-1.5D	5	6	12	18	15	11	9	9	20

Model	Sound attenuation by frequency band [dB]								LwA [dBA] Sound-power level, A-weighted
	63 Hz	125 Hz	250 Hz	500 Hz	1000 Hz	2000 Hz	4000 Hz	8000 Hz	
SD-400-2D	4	6	10	16	21	18	15	13	25
SD-450-2D	4	7	10	17	21	18	15	13	25
SD-500-2D	4	7	10	18	21	17	15	12	24
SD-560-2D	5	7	11	18	21	17	15	12	24
SD-630-2D	5	8	11	21	23	17	15	10	26
SD-710-2D	5	8	12	22	23	16	15	10	26
SD-800-2D	5	8	12	22	23	16	15	10	26
SD-900-2D	5	8	13	22	19	13	12	10	23
SD-1000-2D	6	8	13	22	19	13	12	10	23
SD-1120-2D	6	8	13	21	18	13	12	11	23
SD-1250-2D	6	8	13	21	18	13	12	11	23

SILENCER SDV

- The silencer is used for attenuation of the operation noise generated by ventilation equipment and spreaded in the the air ducts. Designed for connection to round air ducts.
- The **SDV** silencer has a polymer-coated steel casing filled with noncombustible material that has a protective coating to prevent fiber deformation. The silencer has an internal sound-absorbing element to increase sound attenuation efficiency.

Model	Dimensions [mm]								Weight [kg]				
	ØD	ØD1	ØD2	L (1D)	L (1.5D)	L (2D)	Md	n	(1D)	(1.5D)	(2D)		
SDV-400-1D	SDV-400-1.5D	SDV-400-2D	400	450	515	402	602	802	M6	12	14.0	19.0	24.0
SDV-450-1D	SDV-450-1.5D	SDV-450-2D	450	500	565	452	677	902	M6	12	17.0	22.0	27.0
SDV-500-1D	SDV-500-1.5D	SDV-500-2D	500	560	615	502	752	1002	M10	12	23.0	31.0	38.0
SDV-560-1D	SDV-560-1.5D	SDV-560-2D	560	620	675	562	842	1122	M10	12	27.0	35.0	46.0
SDV-630-1D	SDV-630-1.5D	SDV-630-2D	630	690	745	632	947	1262	M10	12	33.0	46.0	59.0
SDV-710-1D	SDV-710-1.5D	SDV-710-2D	710	770	825	712	1067	1422	M10	16	39.0	55.0	71.0
SDV-800-1D	SDV-800-1.5D	SDV-800-2D	800	860	903	801	1202	1601	M10	16	53.0	74.0	100.6
SDV-900-1D	SDV-900-1.5D	SDV-900-2D	900	970	1003	901	1382	1801	M10	16	63.0	84.0	126.0
SDV-1000-1D	SDV-1000-1.5D	SDV-1000-2D	1000	1070	1120	1002	1502	2002	M10	16	85.0	120.0	170.0
SDV-1120-1D	SDV-1120-1.5D	SDV-1120-2D	1120	1190	1273	1122	1682	2242	M12	20	105.0	148.0	210.0
SDV-1250-1D	SDV-1250-1.5D	SDV-1250-2D	1250	1320	1410	1252	1877	2502	M12	20	134.0	190.0	260.0

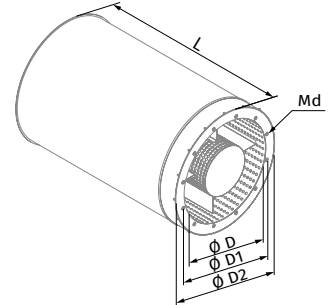

Noise level reduction

- The values shown in the tables represent the difference between the sound power level (L_w) of the combination of the fan, the attenuator and the power of one fan.
- To determine the sound power level of the fan equipped with a silencer, the insertion loss must be subtracted from the rated sound power level (L_w) of the fan on the mid-frequency spectrum in the octave band given in the fan specifications.

Model	Sound attenuation by frequency band [dB]								L_{WA} [dBA] Sound-power level, A-weighted
	63 Hz	125 Hz	250 Hz	500 Hz	1000 Hz	2000 Hz	4000 Hz	8000 Hz	
SDV-400-1D	4	6	9	14	21	19	16	13	25
SDV-450-1D	4	6	9	15	21	19	16	13	25
SDV-500-1D	4	6	9	15	22	19	15	12	25
SDV-560-1D	4	6	9	15	22	19	15	12	25
SDV-630-1D	4	6	10	18	22	19	15	11	25
SDV-710-1D	5	6	10	18	22	19	15	11	25
SDV-800-1D	5	6	10	18	24	17	15	11	26
SDV-900-1D	5	7	11	20	20	16	13	11	24
SDV-1000-1D	5	7	12	20	19	14	13	10	23
SDV-1120-1D	5	7	12	20	19	14	13	10	23
SDV-1250-1D	5	7	12	20	19	14	13	10	23

Model	Sound attenuation by frequency band [dB]								L_{WA} [dBA] Sound-power level, A-weighted
	63 Hz	125 Hz	250 Hz	500 Hz	1000 Hz	2000 Hz	4000 Hz	8000 Hz	
SDV-400-1.5D	5	8	12	18	25	24	21	18	29
SDV-450-1.5D	5	8	12	19	25	24	21	18	29
SDV-500-1.5D	6	8	12	20	26	24	21	17	30
SDV-560-1.5D	6	8	12	20	26	24	21	17	30
SDV-630-1.5D	6	9	13	23	28	26	22	16	31
SDV-710-1.5D	7	9	13	23	28	25	22	16	31
SDV-800-1.5D	7	9	13	23	29	24	22	16	32
SDV-900-1.5D	7	9	15	24	24	22	18	15	28
SDV-1000-1.5D	7	9	16	24	24	21	18	15	28
SDV-1120-1.5D	7	9	16	24	24	21	18	14	28
SDV-1250-1.5D	7	9	16	24	24	21	18	14	28

Model	Sound attenuation by frequency band [dB]								L_{WA} [dBA] Sound-power level, A-weighted
	63 Hz	125 Hz	250 Hz	500 Hz	1000 Hz	2000 Hz	4000 Hz	8000 Hz	
SDV-400-2D	6	9	14	22	29	28	26	23	34
SDV-450-2D	6	9	14	22	29	28	26	23	34
SDV-500-2D	7	10	14	24	30	29	27	22	35
SDV-560-2D	7	10	14	24	30	29	27	22	35
SDV-630-2D	7	11	16	28	33	32	29	20	37
SDV-710-2D	8	11	16	28	34	31	28	20	37
SDV-800-2D	8	11	16	28	34	31	28	20	37
SDV-900-2D	8	11	18	27	28	27	23	19	33
SDV-1000-2D	8	11	19	27	29	27	23	19	33
SDV-1120-2D	8	11	19	27	28	27	22	17	33
SDV-1250-2D	8	11	19	27	28	27	22	17	33

Pressure drops

Model	Air speed 5 m/s		Air speed 10 m/s		Air speed 15 m/s	
	Air flow [m³/h]	Pressure drop [Pa]	Air flow [m³/h]	Pressure drop [Pa]	Air flow [m³/h]	Pressure drop [Pa]
SRV-400-1D	1900	6	3600	25	5300	66
SRV-450-1D	2200	7	4200	26	6200	68
SRV-500-1D	2900	8	5600	31	8300	67
SRV-560-1D	3400	5	6600	17	9800	44
SRV-630-1D	4600	6	9000	19	13300	41
SRV-710-1D	5300	4	10400	11	15500	25
SRV-800-1D	7200	5	14200	15	21200	38
SRV-900-1D	9600	4	19000	19	28400	57
SRV-1000-1D	8400	4	16500	11	24700	29
SRV-1120-1D	12000	5	23700	17	35500	44
SRV-1250-1D	16300	6	32400	24	48500	58

Model	Air speed 5 m/s		Air speed 10 m/s		Air speed 15 m/s	
	Air flow [m³/h]	Pressure drop [Pa]	Air flow [m³/h]	Pressure drop [Pa]	Air flow [m³/h]	Pressure drop [Pa]
SRV-400-1.5D	1900	9	3600	33	5300	80
SRV-450-1.5D	2200	10	4200	34	6200	82
SRV-500-1.5D	2900	11	5600	40	8300	84
SRV-560-1.5D	3400	6	6600	22	9800	53
SRV-630-1.5D	4600	7	9000	25	13300	52
SRV-710-1.5D	5300	5	10400	14	15500	33
SRV-800-1.5D	7200	6	14200	20	21200	51
SRV-900-1.5D	9600	5	19000	24	28400	72
SRV-1000-1.5D	8400	5	16500	14	24700	36
SRV-1120-1.5D	12000	6	23700	21	35500	56
SRV-1250-1.5D	16300	7	32400	30	48500	75

Model	Air speed 5 m/s		Air speed 10 m/s		Air speed 15 m/s	
	Air flow [m³/h]	Pressure drop [Pa]	Air flow [m³/h]	Pressure drop [Pa]	Air flow [m³/h]	Pressure drop [Pa]
SRV-400-2D	1900	11	3600	40	5300	94
SRV-450-2D	2200	12	4200	41	6200	96
SRV-500-2D	2900	13	5600	48	8300	100
SRV-560-2D	3400	7	6600	27	9800	62
SRV-630-2D	4600	8	9000	30	13300	63
SRV-710-2D	5300	5.5	10400	17	15500	41
SRV-800-2D	7200	6.5	14200	24	21200	63
SRV-900-2D	9600	6	19000	29	28400	87
SRV-1000-2D	8400	6	16500	16	24700	43
SRV-1120-2D	12000	6	23700	24	35500	67
SRV-1250-2D	16300	8	32400	36	48500	91

PROTECTIVE MESH SZ-AF

- o Protects the fans against ingress of foreign objects.
- o Protective mesh with 25x25 mm cells

Model	Dimensions [mm]					Weight [kg]
	ØD	ØD1	ØD2	Ød	n	
SZ-AF-400	400	450	490	8	12	1.28
SZ-AF-450	450	500	540	8	12	1.45
SZ-AF-500	500	560	600	12	12	1.77
SZ-AF-560	560	620	660	12	12	2.0
SZ-AF-630	630	690	730	12	12	2.28
SZ-AF-710	710	770	810	12	16	2.59
SZ-AF-800	800	860	900	12	16	2.97
SZ-AF-900	900	970	1015	15	16	3.83
SZ-AF-1000	1000	1070	1115	15	16	4.32
SZ-AF-900	900	970	1015	15	16	3.83
SZ-AF-1000	1000	1070	1115	15	16	4.32
SZ-AF-1120	1120	1190	1270	15	20	6.2
SZ-AF-1250	1250	1320	1400	15	20	7.03

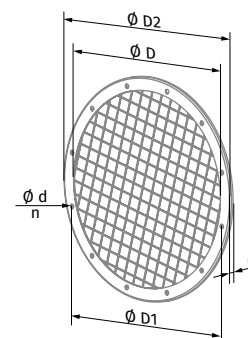

SPRING-LOADED ANTIVIBRATION MOUNT SIF-AF

- The **SIF-AF** antivibration mounts are used for attenuation of noise and vibration generated by ventilation equipment. The antivibration mounts reduce dynamic loads, increase reliability and durability of ventilation equipment.
- **Four antivibration mounts are required to complete one fan.**

Model	Load [kg]	Dimensions and mounting holes [mm]				
		L	H	C	$\varnothing d$	Width
SIF-AF-1	7	105	70	82	10.5	58
SIF-AF-2	15	105	70	82	10.5	58
SIF-AF-3	24	105	80	82	10.5	58
SIF-AF-4	29	105	90	82	10.5	58
SIF-AF-5	35	105	113	82	10.5	58
SIF-AF-6	50	105	113	82	10.5	58
SIF-AF-7	80	105	113	82	10.5	58
SIF-AF-8	120	105	113	82	10.5	58

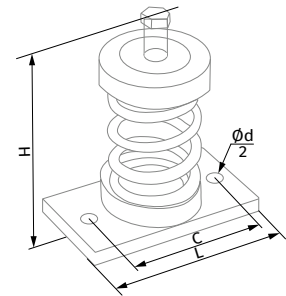

RUBBER ANTIVIBRATION MOUNT SIG-AF

- The rubber antivibration mounts **SIG-AF** are used for attenuation of noise and vibration generated by ventilation equipment.
- The antivibration mounts reduce dynamic loads, increase reliability and durability of ventilation equipment.
- **Four antivibration mounts are required to complete one fan.**

Model	Load [kg]	Dimensions and mounting holes [mm]						
		A	B	C	$\varnothing d$	E	L	H
SIG-AF-1	5-35	5	M8	60	9	$\varnothing 30$	80	40
SIG-AF-2	35-80	10	M10	76	11	$\varnothing 40$	105	52
SIG-AF-3	50-120	10	M10	76	11	$\varnothing 45$	105	52

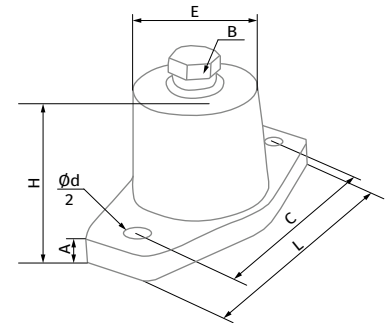

SMOKE EXTRACTION FANS FOR PARKING

Jet axial fans Axis-Jet	128
Impulse centrifugal fans Centro-Jet	132

AXIS-JET

Jet axial fans

Use

- The **Axis-Jet** axial fans are designed for general purpose ventilation of underground and semiopened car parks, ventilation of tunnels, smoke extraction in case of fire as a part of smoke extract system. The fans generate a high-speed and high-pressure directed air jet.

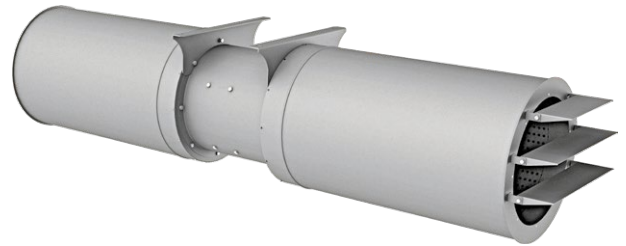

Design

- The casing of the **Axis-Jet** fan has a tubular shape and is made of polymer coated steel. The fan has a sound insulation of mineral wool. The casing includes inner brackets for motor fixation. These brackets act as directing vanes and distribute air flow uniformly, thus increasing aerodynamic performance of the fan.

Modifications

- Unidirectional single-speed
- Unidirectional double-speed
- Reversible single-speed
- Reversible double-speed

Motor

- The three-phase asynchronous motor with a short-circuit rotor is installed in the fan casing. The motor ingress protection rating is IP55. The motor design ensures operation of the fan in the smoke extraction systems on unidirectional and reverse modes. The motors are rated for 400 V power mains voltage and 50 Hz frequency.

Impeller

- Dynamically balanced impeller made of cast aluminium alloy. The reversible fans are equipped with a 100 % reversible two-directional impeller.

Mounting

- The Axis-Jet fans are designed for horizontal ceiling mounting and fixation by means of the supplied fixing brackets attached to the fan casing.

Overall dimensions

Model	Dimensions [mm]						Weight [kg]
	Ø D1	A	B	H	L1	L2	
Unidirectional							
Axis-Jet-CI-315-U	414	302	355	425	1654	1763	40
Axis-Jet-CI-355-U	467	302	420	482	1954	2079	50
Axis-Jet-CI-400-U	515	351	460	525	2004	2129	65
Axis-Jet-CI-450-U	565	351	500	575	2004	2129	85
Axis-Jet-CI-500-U	603	371	580	620	2004	2145	110
Axis-Jet-CI-560-U	663	446	620	678	2093	2247	155
Axis-Jet-CI-630-U	733	550	710	748	2193	2357	245
Reversible							
Axis-Jet-CI-315-R	414	302	355	425	1654	1872	40
Axis-Jet-CI-355-R	467	302	420	482	1954	2202	50
Axis-Jet-CI-400-R	515	351	460	525	2004	2253	65
Axis-Jet-CI-450-R	565	351	500	575	2004	2253	85
Axis-Jet-CI-500-R	603	371	580	620	2004	2290	110
Axis-Jet-CI-560-R	663	446	620	678	2093	2400	155
Axis-Jet-CI-630-R	733	550	710	748	2193	2520	245

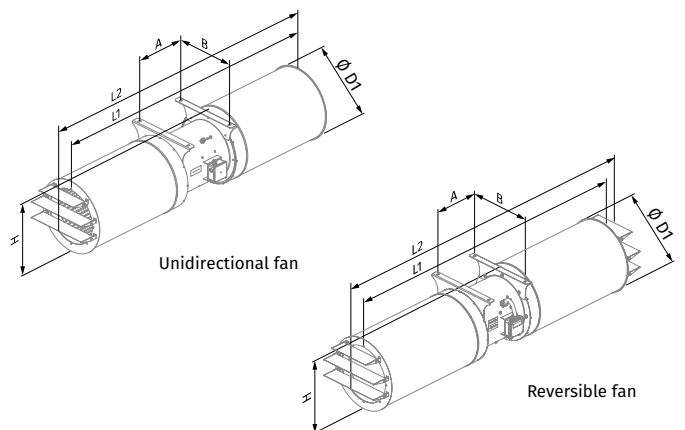

The fans with the fire resistance rating 200 °C/2 hrs can be manufactured on special request.

Designation key

Model	Casing type	Casing insulation	Diameter [mm]	Motor	Number of poles	Air flow	Fire resistance limit/hrs
AXIS-JET: jet axial fan	- C: round	_: without sound-insulation I: sound-insulated casing	- 315; 355; 400; 450; 500; 560; 630	_: standard motor M, S: model with a high-power motor	- 2 (for single-speed motors) 2/4 (for double-speed motors)	U: unidirectional R: reversible	- _: max. +55 °C 300/2: 300 °C/2 hrs 400/2: 400 °C/2 hrs

Design

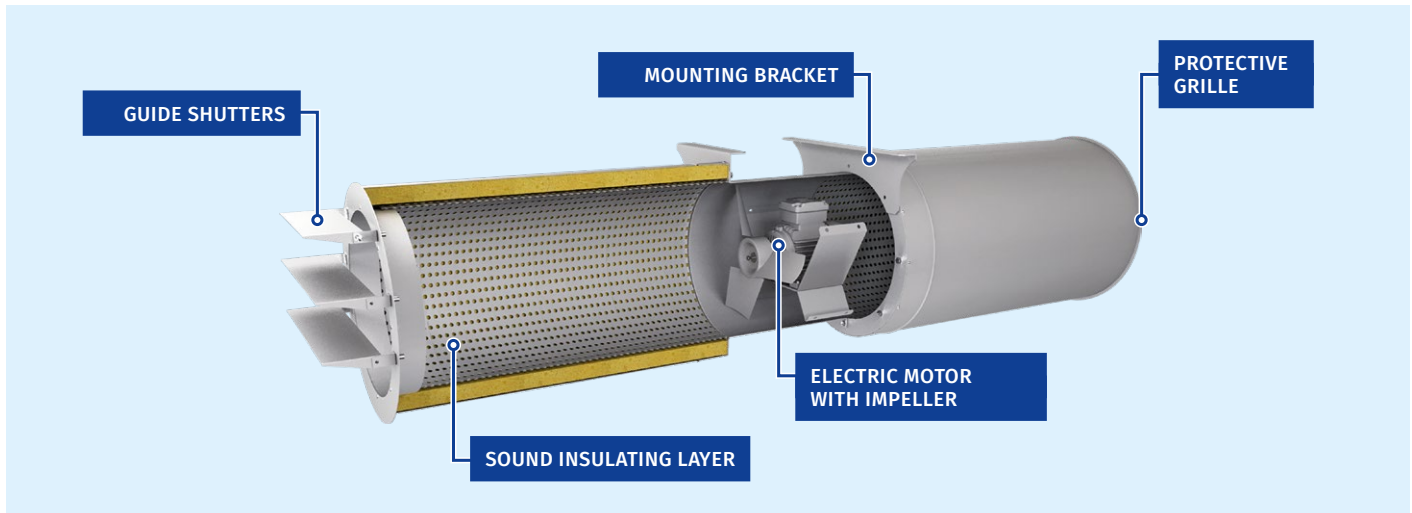

Technical data

Ø [mm]	Air flow direction	Number of speeds	Model	Power [kW]	Max. air flow [m³/h]	Fan pull [N]	Air speed [m/s]	RPM	Operating temperature [°C]	Sound pressure Lp(A), dB in 3 m	
315	Unidirectional	1	AXIS-JET-CI-315-2-U	0.55	4520	26	17.2	2880	-25...+55 °C	63	
			AXIS-JET-CI-315-2-U-300/2		4520	26	17.2		300 °C/2 h	63	
			AXIS-JET-CI-315-2-U-400/2		3250	14	12.4		400 °C/2 h	63	
		AXIS-JET-CI-315M-2-U	0.75	1	4990	32	19	2880	-25...+55 °C	64	
		AXIS-JET-CI-315M-2-U-300/2			4990	32	19		300 °C/2 h	64	
		AXIS-JET-CI-315M-2-U-400/2			3590	16	13.6		400 °C/2 h	65	
		AXIS-JET-CI-315-2/4-U	2	2	4520 / 2260	26 / 13	17.2 / 8.6	2880 / 1440	-25...+55 °C	63/48	
		AXIS-JET-CI-315-2/4-U-300/2			0.55 / 0.11	4520 / 2260	26 / 13		17.2 / 8.6	300 °C/2 h	63/48
		AXIS-JET-CI-315-2/4-U-400/2			0.8 / 0.2	3250 / 1630	14 / 7		12.4 / 6.18	400 °C/2 h	63/48
	AXIS-JET-CI-315M-2/4-U	0.55 / 0.11			4990 / 2490	32 / 16	19 / 9.5		-25...+55 °C	64/49	
	AXIS-JET-CI-315M-2/4-U-300/2	0.8 / 0.2			4990 / 2490	32 / 16	19 / 9.5		300 °C/2 h	64/49	
	AXIS-JET-CI-315M-2/4-U-400/2	0.8 / 0.2			3590 / 1790	16 / 8	13.6 / 6.8		400 °C/2 h	65/50	
	Reversible	1	AXIS-JET-CI-315-2-R	0.55	4190	22	15.9	2880	-25...+55 °C	67	
			AXIS-JET-CI-315-2-R-300/2		4190	22	15.9		300 °C/2 h	67	
			AXIS-JET-CI-315-2-R-400/2		3010	12	11.4		400 °C/2 h	68	
		AXIS-JET-CI-315-2/4-R	2	2	4180 / 2100	22 / 11	15.9 / 7.9	2880 / 1440	-25...+55 °C	67/52	
		AXIS-JET-CI-315-2/4-R-300/2			0.55 / 0.11	4180 / 2100	22 / 11		15.9 / 7.9	300 °C/2 h	67/52
		AXIS-JET-CI-315-2/4-R-400/2			0.55 / 0.11	3010 / 1510	12 / 6		11.4 / 5.7	400 °C/2 h	68/53
355	Unidirectional	1	AXIS-JET-CI-355-2-U	0.75	5830	34	17.3	2880	-25...+55 °C	65	
			AXIS-JET-CI-355-2-U-300/2		5830	34	17.3		300 °C/2 h	65	
			AXIS-JET-CI-355-2-U-400/2		4880	24	14.5		400 °C/2 h	65	
		AXIS-JET-CI-355M-2-U	1.1	1	6740	45	20.0	2880	-25...+55 °C	64	
		AXIS-JET-CI-355M-2-U-300/2			6740	45	20.0		300 °C/2 h	64	
		AXIS-JET-CI-355M-2-U-400/2			5360	29	15.9		400 °C/2 h	67	
		AXIS-JET-CI-355-2/4-U	2	2	5830 / 3000	34 / 17	17.3 / 8.9	2880 / 1440	-25...+55 °C	65/50	
		AXIS-JET-CI-355-2/4-U-300/2			0.8 / 0.2	5830 / 3000	34 / 17		17.3 / 8.9	300 °C/2 h	65/50
		AXIS-JET-CI-355-2/4-U-400/2			0.8 / 0.2	4880 / 2440	24 / 12		14.5 / 7.3	400 °C/2 h	65/50
	AXIS-JET-CI-355M-2/4-U	1.1 / 0.25			6740 / 3370	45 / 23	20.0 / 10.0		-25...+55 °C	64/49	
	AXIS-JET-CI-355M-2/4-U-300/2	1.1 / 0.25			6740 / 3370	45 / 23	20.0 / 10.0		300 °C/2 h	64/49	
	AXIS-JET-CI-355M-2/4-U-400/2	1.1 / 0.25			5360 / 2680	29 / 14	15.9 / 8		400 °C/2 h	67/52	
	Reversible	1	AXIS-JET-CI-355-2-R	1.1	5810	34	17.3	2880	-25...+55 °C	68	
			AXIS-JET-CI-355-2-R-300/2		5810	34	17.3		300 °C/2 h	68	
			AXIS-JET-CI-355-2-R-400/2		5160	27	15.3		400 °C/2 h	70	
		AXIS-JET-CI-355-2/4-R	2	2	5810 / 2900	34 / 17	17.3 / 8.6	2810 / 1390	-25...+55 °C	68/53	
		AXIS-JET-CI-355-2/4-R-300/2			1.1 / 0.25	5810 / 2900	34 / 17		17.3 / 8.6	300 °C/2 h	68/53
		AXIS-JET-CI-355-2/4-R-400/2			1.1 / 0.25	5160 / 2580	27 / 13		15.3 / 7.7	400 °C/2 h	70/55

* Smoke extraction mode: once for two hours

Ø [mm]	Air flow direction	Number of speeds	Model	Power [kW]	Max. air flow [m³/h]	Fan pull [N]	Air speed [m/s]	RPM	Operating temperature [°C]	Sound pressure Lp(A), dB in 3 m		
400	Unidirectional	1	AXIS-JET-CI-400-2-U	1.1	8500	57	20.0	2880	-25...+55 °C	69		
			AXIS-JET-CI-400-2-U-300/2		8500	57	20.0		300 °C/2 h	69		
			AXIS-JET-CI-400-2-U-400/2		6970	38	16.4		400 °C/2 h	70		
			AXIS-JET-CI-400M-2-U		2.2	9870	77		23.2	-25...+55 °C	67	
			AXIS-JET-CI-400M-2-U-300/2			9870	77		23.2	300 °C/2 h	67	
			AXIS-JET-CI-400M-2-U-400/2			8500	57		20	400 °C/2 h	69	
		2	AXIS-JET-CI-400-2/4-U	1.1 / 0.25	8500 / 4250	57 / 28	20.0 / 10.0	-25...+55 °C	69/54			
			AXIS-JET-CI-400-2/4-U-300/2		8500 / 4250	57 / 28	20.0 / 10.0	300 °C/2 h	69/54			
			AXIS-JET-CI-400-2/4-U-400/2		6970 / 3490	38 / 19	16.4 / 8.2	400 °C/2 h	70/55			
			AXIS-JET-CI-400M-2/4-U		2.2 / 0.5	9870 / 4930	77 / 38	23.2 / 11.6	-25...+55 °C	67/52		
			AXIS-JET-CI-400M-2/4-U-300/2			9870 / 4930	77 / 38	23.2 / 11.6	300 °C/2 h	67/52		
			AXIS-JET-CI-400M-2/4-U-400/2			8500 / 4250	57 / 28	20 / 10	400 °C/2 h	69/54		
	Reversible	1	AXIS-JET-CI-400-2-R	1.5	8290	54	19.5	2880	-25...+55 °C	70		
			AXIS-JET-CI-400-2-R-300/2		8290	54	19.5		300 °C/2 h	70		
			AXIS-JET-CI-400-2-R-400/2		7140	40	16.8		400 °C/2 h	71		
		2	AXIS-JET-CI-400-2/4-R	1.5 / 0.37	8290 / 4140	54 / 27	19.5 / 9.7	-25...+55 °C	70/55			
			AXIS-JET-CI-400-2/4-R-300/2		8290 / 4140	54 / 27	19.5 / 9.7	300 °C/2 h	70/55			
			AXIS-JET-CI-400-2/4-R-400/2		7140 / 3570	40 / 20	16.8 / 8.4	400 °C/2 h	71/56			
450	Unidirectional	1	AXIS-JET-CI-450-2-U	1.5	10400	67	19.3	2880	-25...+55 °C	67		
			AXIS-JET-CI-450-2-U-300/2		10400	67	19.3		300 °C/2 h	67		
			AXIS-JET-CI-450-2-U-450/2		9520	56	17.6		400 °C/2 h	67		
			AXIS-JET-CI-450M-2-U		2.2	12800	98		23.3	-25...+55 °C	70	
			AXIS-JET-CI-450M-2-U-300/2			12800	98		23.3	300 °C/2 h	70	
			AXIS-JET-CI-450M-2-U-400/2			11600	83		21.5	400 °C/2 h	70	
			2		AXIS-JET-CI-450S-2-U	3	14100		123	26.2	-25...+55 °C	69
					AXIS-JET-CI-450S-2-U-300/2		14100		123	26.2	300 °C/2 h	69
					AXIS-JET-CI-450S-2-U-400/2		12300		93	22.7	400 °C/2 h	72
		AXIS-JET-CI-450-2/4-U		1.5 / 0.37	10400 / 5220		67 / 34	19.3 / 9.7	-25...+55 °C	67/52		
		AXIS-JET-CI-450-2/4-U-300/2			10400 / 5220		67 / 34	19.3 / 9.7	300 °C/2 h	67/52		
		AXIS-JET-CI-450-2/4-U-400/2			9520 / 4760		56 / 28	17.6 / 8.8	400 °C/2 h	67/52		
		Reversible		1	AXIS-JET-CI-450M-2/4-U		2.2 / 0.5	12800 / 6290	98 / 49	23.3 / 11.7	-25...+55 °C	70/55
					AXIS-JET-CI-450M-2/4-U-300/2			12800 / 6290	98 / 49	23.3 / 11.7	300 °C/2 h	70/55
					AXIS-JET-CI-450M-2/4-U-400/2			11600 / 6070	83 / 42	21.5 / 11.3	400 °C/2 h	70/55
			2	AXIS-JET-CI-450S-2/4-U	3.1 / 0.8	14100 / 7070	124 / 62	26.2 / 13.1	-25...+55 °C	69/54		
				AXIS-JET-CI-450S-2/4-U-300/2		14100 / 7070	124 / 62	26.2 / 13.1	300 °C/2 h	69/54		
				AXIS-JET-CI-450S-2/4-U-400/2		12400 / 6200	93 / 47	22.9 / 11.5	400 °C/2 h	72/57		
	AXIS-JET-CI-450-2-R			1.5		9280	53	17.2	-25...+55 °C	73		
	AXIS-JET-CI-450-2-R-300/2					9280	53	17.2	300 °C/2 h	73		
	AXIS-JET-CI-450-2-R-450/2					8560	45	15.8	400 °C/2 h	71		
	2	AXIS-JET-CI-450M-2-R	3	10400	67	19.2	-25...+55 °C	72				
		AXIS-JET-CI-450M-2-R-300/2		10400	67	19.2	300 °C/2 h	72				
		AXIS-JET-CI-450M-2-R-400/2		10300	66	19.1	400 °C/2 h	73				
		AXIS-JET-CI-450S-2-R		2.2	12800	102	23.7	-25...+55 °C	74			
		AXIS-JET-CI-450S-2-R-300/2			12800	102	23.7	300 °C/2 h	74			
		AXIS-JET-CI-450S-2-R-400/2			11200	78	20.8	400 °C/2 h	74			
		1		AXIS-JET-CI-450-2/4-R	1.5 / 0.37	9280 / 4640	53 / 27	17.2 / 8.6	-25...+55 °C	73/58		
				AXIS-JET-CI-450-2/4-R-300/2		9280 / 4640	53 / 27	17.2 / 8.6	300 °C/2 h	73/58		
				AXIS-JET-CI-450-2/4-R-400/2		8560 / 4280	45 / 23	15.8 / 7.9	400 °C/2 h	71/56		
AXIS-JET-CI-450M-2/4-R	2.2 / 0.5		10400 / 5190	67 / 33		19.2 / 9.6	-25...+55 °C	72/57				
AXIS-JET-CI-450M-2/4-R-300/2			10400 / 5190	67 / 33		19.2 / 9.6	300 °C/2 h	72/57				
AXIS-JET-CI-450M-2/4-R-400/2			10300 / 5160	66 / 33		19.1 / 9.6	400 °C/2 h	73/58				
2	AXIS-JET-CI-450S-2/4-R	3.1 / 0.8	12800 / 6400	102 / 51	23.7 / 11.9	-25...+55 °C	74/59					
	AXIS-JET-CI-450S-2/4-R-300/2		12800 / 6400	102 / 51	23.7 / 11.9	300 °C/2 h	74/59					
	AXIS-JET-CI-450S-2/4-R-400/2		11200 / 5610	78 / 39	20.8 / 10.4	400 °C/2 h	74/59					

* Smoke extraction mode: once for two hours

Ø [mm]	Air flow direction	Number of speeds	Model	Power [kW]	Max. air flow [m³/h]	Fan pull [N]	Air speed [m/s]	RPM	Operating temperature [°C]	Sound pressure Lp(A), dB in 3 m
500	Unidirectional	2	AXIS-JET-CI-500-2/4-U	3.1 / 0.8	16200 / 8120	132 / 66	24.3 / 12.2	2880 / 1440	-25...+55 °C	72/57
			AXIS-JET-CI-500-2/4-U-300/2		16200 / 8120	132 / 66	24.3 / 12.2		300 °C/2 h	72/57
			AXIS-JET-CI-500-2/4-U-400/2	14900 / 7430	111 / 55	22.2 / 11.1	400 °C/2 h		70/55	
			AXIS-JET-CI-500M-2/4-U	4.4 / 1.1	18500 / 9240	171 / 86	27.7 / 13.8		-25...+55 °C	72/57
			AXIS-JET-CI-500M-2/4-U-300/2		18500 / 9240	171 / 86	27.7 / 13.8		300 °C/2 h	72/57
			AXIS-JET-CI-500M-2/4-U-400/2		17200 / 8600	149 / 74	25.8 / 12.9		400 °C/2 h	74/59
	Reversible	2	AXIS-JET-CI-500-2/4-R	3.1 / 0.8	14500 / 7250	105 / /52	21.7 / 10.8	-25...+55 °C	77/62	
			AXIS-JET-CI-500-2/4-R-300/2		14500 / 7250	105 / /52	21.7 / 10.8	300 °C/2 h	77/62	
			AXIS-JET-CI-500-2/4-R-400/2	13600 / 6790	93 / 46	20.3 / 10.2	400 °C/2 h	75/60		
			AXIS-JET-CI-500M-2/4-R	4.4 / 1.1	16600 / 8310	139 / 69	24.8 / 12.4	-25...+55 °C	76/61	
			AXIS-JET-CI-500M-2/4-R-300/2		16600 / 8310	139 / 69	24.8 / 12.4	300 °C/2 h	76/61	
			AXIS-JET-CI-500M-2/4-R-400/2		15900 / 7940	127 / 63	23.8 / 11.9	400 °C/2 h	77/62	
560	Unidirectional	2	AXIS-JET-CI-560-2/4-U	4.4 / 1.1	20200 / 10100	167 / 84	24.7 / 12.4	2880 / 1440	-25...+55 °C	74/59
			AXIS-JET-CI-560-2/4-U-300/2		20200 / 10100	167 / 84	24.7 / 12.4		300 °C/2 h	74/59
			AXIS-JET-CI-560-2/4-U-400/2	18000 / 9010	133 / 66	22 / 11	400 °C/2 h		74/59	
			AXIS-JET-CI-560M-2/4-U	8 / 2	25100 / 12500	258 / 129	30.7 / 15.3		-25...+55 °C	76/61
			AXIS-JET-CI-560M-2/4-U-300/2		25100 / 12500	258 / 129	30.7 / 15.3		300 °C/2 h	76/61
			AXIS-JET-CI-560M-2/4-U-400/2		24300 / 12200	242 / 121	29.8 / 14.9		400 °C/2 h	77/62
	Reversible	2	AXIS-JET-CI-560-2/4-R	4.4 / 1.1	16800 / 8410	116 / 58	20.5 / 10.3	-25...+55 °C	77/62	
			AXIS-JET-CI-560-2/4-R-300/2		16800 / 8410	116 / 58	20.5 / 10.3	300 °C/2 h	77/62	
			AXIS-JET-CI-560-2/4-R-400/2	17200 / 8900	121 / 60	21 / 10.9	400 °C/2 h	77/62		
			AXIS-JET-CI-560M-2/4-R	6 / 1.5	21100 / 10500	182 / 91	25.8 / 12.9	-25...+55 °C	79/64	
			AXIS-JET-CI-560M-2/4-R-300/2		21100 / 10500	182 / 91	25.8 / 12.9	300 °C/2 h	79/64	
			AXIS-JET-CI-560M-2/4-R-400/2		18800 / 9380	145 / 72	23 / 11.5	400 °C/2 h	77/62	
630	Unidirectional	2	AXIS-JET-CI-630-2/4-U	12 / 3	31500 / 15700	320 / 160	30.4 / 15.2	2880 / 1440	-25...+55 °C	79/64
			AXIS-JET-CI-630-2/4-U-300/2		31500 / 15700	320 / 160	30.4 / 15.2		300 °C/2 h	79/64
			AXIS-JET-CI-630-2/4-U-400/2	31500 / 15750	320 / 160	30.4 / 15.2	400 °C/2 h		77/62	
			AXIS-JET-CI-630M-2/4-U	16 / 4	35200 / 176500	400 / 200	34 / 17		-25...+55 °C	81/66
			AXIS-JET-CI-630M-2/4-U-300/2		35200 / 176500	400 / 200	34 / 17		300 °C/2 h	81/66
			AXIS-JET-CI-630M-2/4-U-400/2		33100 / 16550	354 / 177	31.9 / 16		400 °C/2 h	78/63
	Reversible	2	AXIS-JET-CI-630-2/4-R	12 / 3	26700 / 13400	232 / 116	25.8 / 12.9	-25...+55 °C	85/70	
			AXIS-JET-CI-630-2/4-R-300/2		26700 / 13400	232 / 116	25.8 / 12.9	300 °C/2 h	85/70	
			AXIS-JET-CI-630-2/4-R-400/2	28800 / 14400	268 / 134	27.9 / 13.9	400 °C/2 h	82/67		
			AXIS-JET-CI-630M-2/4-R	16 / 4	29100 / 14600	274 / 137	28.2 / 14.1	-25...+55 °C	86/71	
			AXIS-JET-CI-630M-2/4-R-300/2		29100 / 14600	274 / 137	28.2 / 14.1	300 °C/2 h	86/71	
			AXIS-JET-CI-630M-2/4-R-400/2		32100 / 16000	334 / 167	31 / 15.5	400 °C/2 h	82/67	

* Smoke extraction mode: once for two hours

CENTRO-JET

Impulse centrifugal fans

Use

- The **Centro-Jet** impulse centrifugal fans are designed for general purpose ventilation of underground and semiopened car parks, smoke extraction in case of fire as a part of smoke extract system.
- The fans generate a high-speed and high-pressure directed air jet.

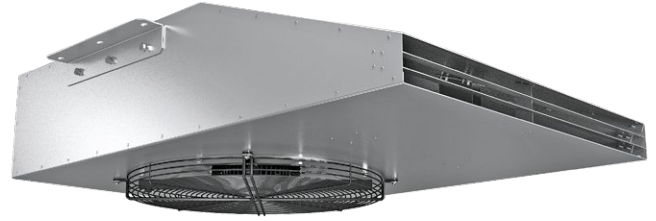

Design

- The casing of the Centro-Jet fan is made of polymer coated steel.
- Due to low height of the casing the fan is recommended for use in low-ceilinged room.
- The protective grille on the intake side prevents ingress of foreign objects into the fan.
- The deflector plates on the exhaust side of the fan ensure correct air flow distribution.

Modifications

- Single-speed
- Double-speed

Motor

- Single- or double-speed 4-, 6- or 8-pole asynchronous motors. The motor ingress protection rating is IP55. The motors are rated for 400 V power mains voltage and 50 Hz frequency.

Impeller

- The impeller with backward curved steel blades.

Mounting

- The Centro-Jet fans are designed for ceiling mounting and fixation by means of the supplied fixing brackets.
- Power is supplied through the internal terminal box.
- The fan wiring and mounting must be made according to the instructions and the wiring diagram shown in the terminal box.

Overall dimensions

Model	Dimensions [mm]					Weight [kg]
	A	B	C	H	K	
Centro-Jet-50N	290	1355	935	90	350	96
Centro-Jet-85N	330	1605	1105	110	390	136
Centro-Jet-100N	330	1605	1105	110	390	138

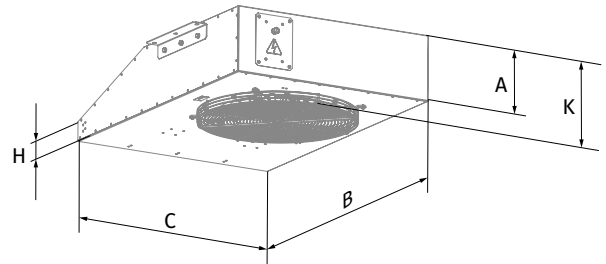

The fans with the fire resistance rating 200 °C/2 hrs can be manufactured on special request.

Designation key

Model	Fan pull [N]	Number of poles	Fire resistance limit/hrs
CENTRO-JET: impulse centrifugal fan	50N	4 (for single-speed models)	- : max. +55 °C 300/2: 300 °C/2 hrs. 400/2: 400 °C/2 hrs.
	85N	4/6 (for double-speed models)	
	100N	4/8 (for double-speed models)	

Design

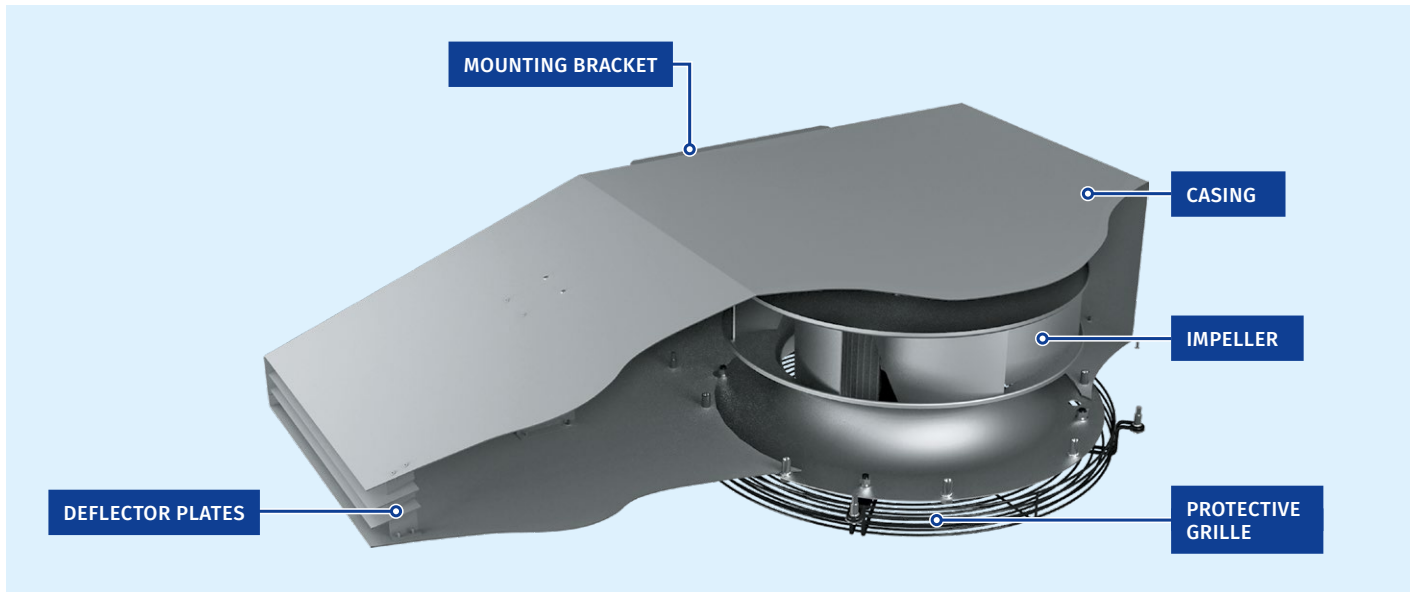

Technical data

Model	Number of speeds	Max. air flow [m³/h]	Power [kW]	Fan pull [N]	Air speed [m/s]	RPM	Operating temperature*	Sound pressure Lp(A), dB in 3 m
Centro-Jet-50N-4	1	6200	1.5	50	20.5	1500	-25...+55 °C	72
Centro-Jet-50N-4-300/2							300 °C/2 h	
Centro-Jet-50N-4-400/2							400 °C/2 h	
Centro-Jet-50N-4/6	2	6200/4100	1.5/0.37	50/20	20.5/13.5	1500/1000	-25...+55 °C	72/59
Centro-Jet-50N-4/6-300/2							300 °C/2 h	
Centro-Jet-50N-4/6-400/2							400 °C/2 h	
Centro-Jet-50N-4/8							-25...+55 °C	
Centro-Jet-50N-4/8-300/2							300 °C/2 h	
Centro-Jet-50N-4/8-400/2	400 °C/2 h							
Centro-Jet-85N-4	1	9750	2.2	85	22.3	1500	-25...+55 °C	76
Centro-Jet-85N-4-300/2							300 °C/2 h	
Centro-Jet-85N-4-400/2							400 °C/2 h	
Centro-Jet-85N-4/6	2	9750/5950	2.2/0.7	85/28	22.3/13.6	1500/1000	-25...+55 °C	76/63
Centro-Jet-85N-4/6-300/2							300 °C/2 h	
Centro-Jet-85N-4/6-400/2							400 °C/2 h	
Centro-Jet-85N-4/8							-25...+55 °C	
Centro-Jet-85N-4/8-300/2							300 °C/2 h	
Centro-Jet-85N-4/8-400/2	400 °C/2 h							
Centro-Jet-100N-4	1	10200	3	100	23.3	1500	-25...+55 °C	78
Centro-Jet-100N-4-300/2							300 °C/2 h	
Centro-Jet-100N-4-400/2							400 °C/2 h	
Centro-Jet-100N-4/8	2	10200/5150	2.8/0.7	100/26	23.3/11.8	1500/750	-25...+55 °C	78/63
Centro-Jet-100N-4/8-300/2							300 °C/2 h	
Centro-Jet-100N-4/8-400/2							400 °C/2 h	

* Smoke extraction mode: once for two hours

FIRE SAFETY DAMPERS

Multi-purpose fire safety smoke dampers RSKE / RSKM	136
Fire-resisting dampers BSK1	150
Fire-resisting dampers BSK2	158
Fire-resisting dampers BSK	168
Smoke exhaust grille D-RSK for fire safety dampers	174
Protective grille S-RSK for fire safety dampers	178
Mounting frame MR RSKE/RSKM for fire safety dampers	180
Aluminium decorative grille SRFS	182

RSKE / RSKM

Multi-purpose fire safety smoke dampers



Normally closed multiple-louvre fire safety dampers RSKM



Normally closed single louvre fire safety dampers RSKE



Fire resistance rating:
600 °C within 180 min.

Use

- The dampers are intended for integration into smoke control systems of buildings and structures of various purpose and designed for extraction of combustion products from the spaces of floor corridors, hallways, air locks etc.
- The dampers can be used as smoke dampers in emergency smoke extraction ventilation systems in the event of a fire to support evacuation of people from the building at the initial phase of the fire occurring in any of the building spaces.
- The RSKE/RSKM multi-purpose fire safety smoke dampers are rated to resist fire for 180 minutes (E 180) at the temperature of 600 °C.

Design

- The damper casing is made of galvanised steel 1.5 mm thick.
- The dampers are available in the wall-mounted or duct-mounted variant which have either one or two attachment flanges.

Control and modifications

- The units are available in two control options (with an electric magnet and with an electric actuator in different configurations):

THE DAMPER WITH AN ELECTRIC MAGNET (220 OR 24 V)

- The damper opens via a spring when the electric magnet is energized. When the damper reaches the end position, a limit switch opens the circuit disconnecting the electric magnet from the power mains. The electric magnet must not remain energized for more than 2 seconds. The damper is reset to the safety (closed) position manually by means of a handle. The damper equipped with an electric magnet has a special button for testing the unit performance.

THE DAMPER WITH A 230 OR 24 V ELECTRIC ACTUATOR AND A RETURN SPRING

- The flaps are automatically set to the normal (closed) position when applying voltage to the electric actuator. On a fire alarm signal the electric actuator is de-energized causing its return spring to set the damper to an open position. The electric actuator is equipped with a contact group to signal its end positions. The damper can also be controlled manually and fixed in any position. The unit can be unlocked either manually using a hex wrench or automatically upon power-up.

THE DAMPER WITH A 230 OR 24 V ELECTRIC ACTUATOR AND TWO-WIRE CONTROL

- The damper flap is set from the "Open" to the "Closed" position by an external command sending the voltage phase from one actuator contact to the other. The electric actuator is equipped with a contact group to signal its end positions. The damper can be controlled manually by means of a hex key.

Note. The RSKM dampers with a height of 300 and 350 mm have one louvre. The main difference between the RSKM and the RSKE dampers with a similar height of 300 and 350 mm is that the method of fastening the flap, which ensures a smaller overhang of the flap beyond the RSKM damper.

Mounting

- The dampers are not intended for installation in air ducts and ducts of spaces with fire and explosion hazard categories A and in local exhaust systems designed for extraction of flammable and explosive mixtures as well as in systems containing environments more aggressive to plain carbon steels than air or those containing sticky and fibrous materials.
- Fire safety dampers are only intended for installation in systems subjected to regular cleaning to prevent formation of flammable deposits.
- The damper must be installed into the building envelope structure in accordance with the applicable standards and regulations. The seal fire resistance must be at least equal to that of the building envelope. When preparing for installation the damper casing should be fitted with wooden spreader bars to prevent deformation, torsional twisting or geometry perturbation of the casing which may result in louvre jamming and, eventually, loss of the damper functionality.

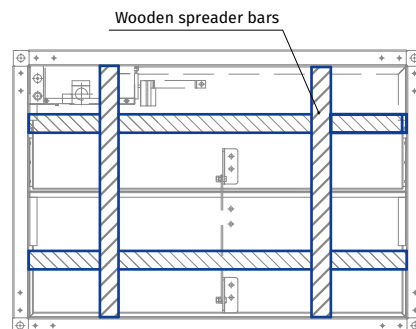

- Upon completion of the damper brickwork envelope in the smoke shaft, fire division wall or flooring and complete cure (setting) of the sealing, remove the wooden spreader bars and check the louvre for free and frictionless opening.
- Ground the damper, connect the electromagnet or electric actuator (depending on the modification) to the automatic fire-fighting system and test the damper actuation.

Designation key

RSKE/RSKM 30 x 30 / 1 PKP24 / O

Damper series:

RSKE: single-louvre

RSKM: multi-louvre

Damper flow area width [cm]:

30; 35; 40; 45; 50; 55; 60; 65; 70; 75; 80; 85; 90; 95; 100

Damper flow area height [cm]:

30; 35; 40; 45; 50; 55; 60; 65; 70; 75; 80; 85; 90; 95; 100

Number of flanges:

1: one

2: two

Actuator type:

EM220/24: 220/24 V electric magnet

PKP24: 24 V ZERN electric actuator with a return spring

PKP230: 230 V ZERN electric actuator with a return spring

PV24: 24 V BELIMO open/close electric actuator

PV230: 230 V BELIMO open/close electric actuator

PVP24: 24 V BELIMO electric actuator with a return spring

PVP230: 230 V BELIMO electric actuator with a return spring

PS24: 24 V SIEMENS open/close electric actuator

PS230: 230 V SIEMENS open/close electric actuator

PSP24: 24 V SIEMENS electric actuator with a return spring

PSP230: 230 V SIEMENS actuator with a return spring

Actuator location:

O: outside (except for EM220/24 electric magnet)

I: inside

Installation recommendation for the RSKM damper with an internally connected actuator

IN VERTICAL BUILDING STRUCTURES

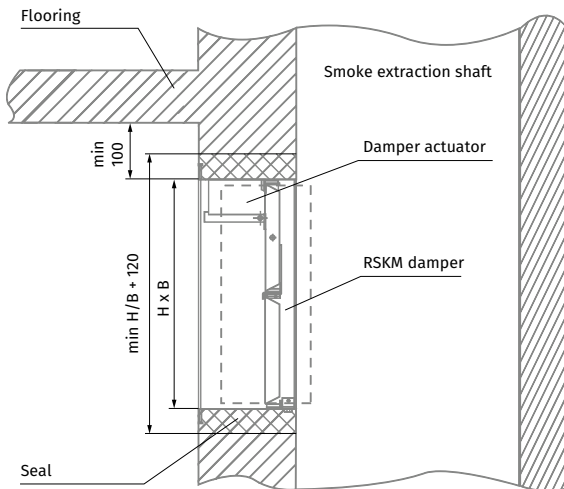

IN HORIZONTAL BUILDING STRUCTURES

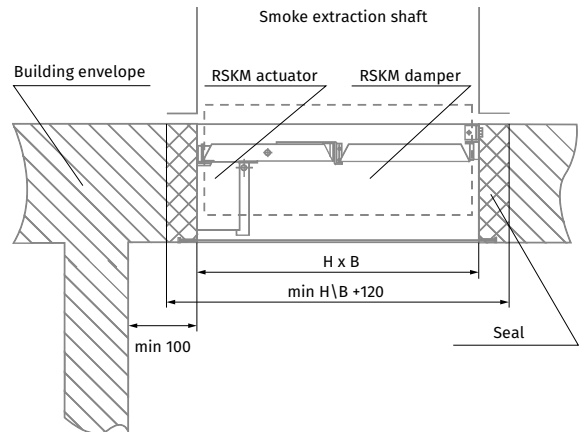

DUCT MODIFICATION WITH AN AIR DUCT

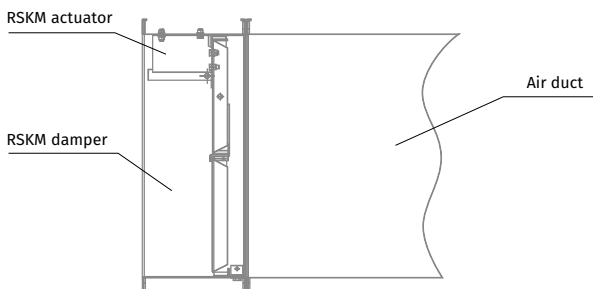

Installation recommendation for the RSKM damper with an externally located actuator

IN VERTICAL BUILDING STRUCTURES

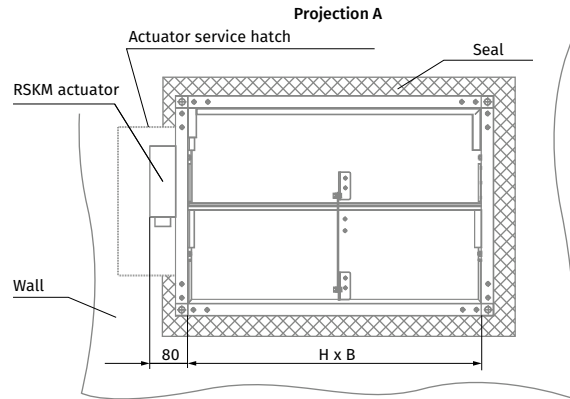
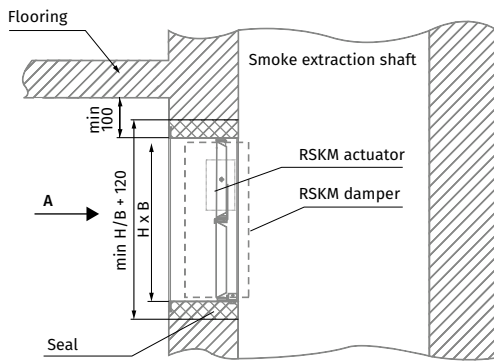

DUCT MODIFICATION WITH AN AIR DUCT

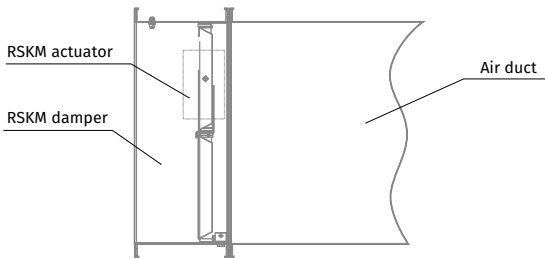

IN HORIZONTAL BUILDING STRUCTURES

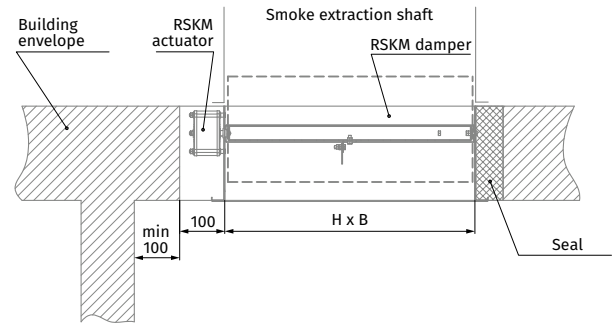

Installation recommendation for the RSKE damper with an internally connected actuator

IN VERTICAL BUILDING STRUCTURES

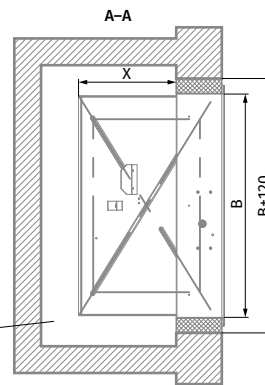
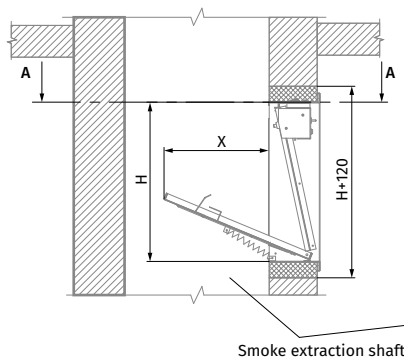

DUCT MODIFICATION WITH AN AIR DUCT

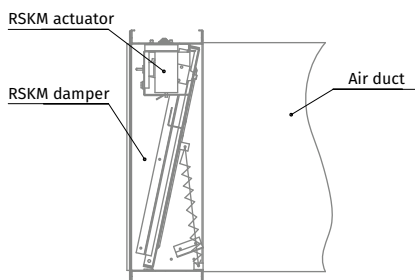

IN HORIZONTAL BUILDING STRUCTURES

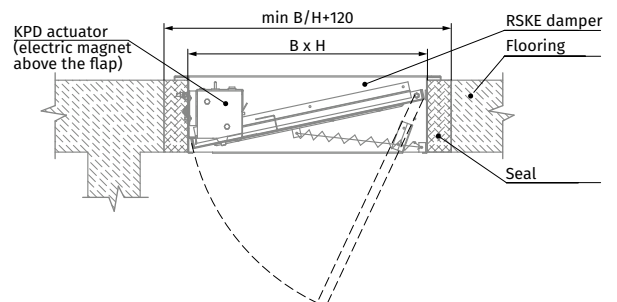

Possible RSKM damper variants

THE RSKM DAMPER WITH AN INTERNALLY INSTALLED ELECTROMAGNET (220/24 V), SINGLE OR DOUBLE FLANGE

- The single flange variant is intended for wall or ceiling mounting irrespective of the dimensional orientation. Upon the test or emergency damper actuation, the louvres can only be manually reset to the initial position.
- The double flange variant is intended for duct installation irrespective of the dimensional orientation. Upon the test or emergency damper actuation the louvres can only be manually reset to the initial position.

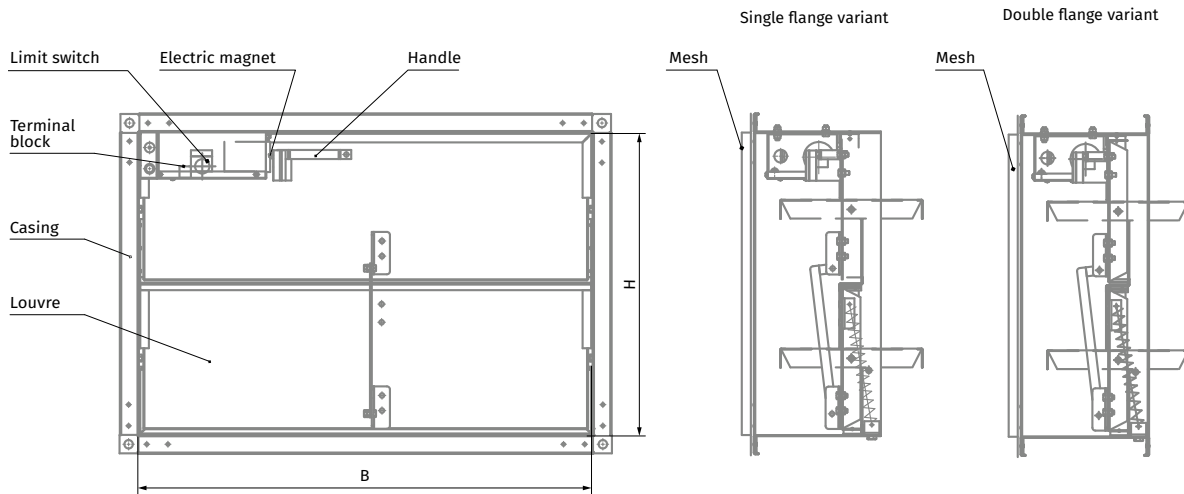

FLOW AREA OF THE RSKM SMOKE EXHAUST DAMPER WITH AN ELECTROMAGNET [m²]

B/H [mm]	300	350	400	450	500	550	600	650	700	750	800	850	900	950	1000
300	0.06														
350	0.08	0.10													
400	0.09	0.11	0.12												
450	0.10	0.13	0.14	0.16											
500	0.12	0.14	0.15	0.18	0.20										
550	0.13	0.16	0.17	0.20	0.23	0.25									
600	0.15	0.18	0.19	0.22	0.25	0.28	0.31								
650	0.16	0.19	0.20	0.24	0.27	0.30	0.33	0.37							
700	0.17	0.21	0.22	0.26	0.29	0.33	0.36	0.40	0.43						
750	0.19	0.22	0.24	0.28	0.31	0.35	0.39	0.43	0.46	0.48					
800	0.20	0.24	0.26	0.30	0.34	0.38	0.42	0.46	0.50	0.51	0.55				
850	0.21	0.26	0.27	0.31	0.36	0.40	0.44	0.48	0.53	0.54	0.59	0.63			
900	0.23	0.27	0.29	0.33	0.38	0.42	0.47	0.51	0.56	0.58	0.62	0.67	0.71		
950	0.24	0.29	0.31	0.35	0.40	0.45	0.50	0.54	0.59	0.61	0.66	0.71	0.75	0.80	
1000	0.25	0.30	0.32	0.37	0.42	0.47	0.52	0.57	0.62	0.64	0.69	0.74	0.79	0.84	0.89

Note: Select the damper of the required cross-section BxH according to the completed table cells. Since the damper can be installed in any spatial position, a change of the height and width (B and H values) orientation may enable selection of a damper with a cross-section beyond the completed cell range.

For example, a 700x500 mm damper can be ordered as 500x700 mm.

**THE RSKM DAMPER WITH AN ELECTRIC ACTUATOR (230 OR 24 V)
INSTALLED INSIDE THE DAMPER, SINGLE OR DOUBLE FLANGE**

- The single flange variant is intended for wall or ceiling mounting irrespective of the dimensional orientation.
- The double flange variant is intended for duct installation irrespective of the dimensional orientation. The louvres of dampers equipped with a

two-position electric actuator are set to the "open" or "closed" position by an external actuating signal. After a test or emergency actuation the louvres of dampers equipped with an electric actuator with a return spring can return to the initial position automatically upon feeding the supply voltage.

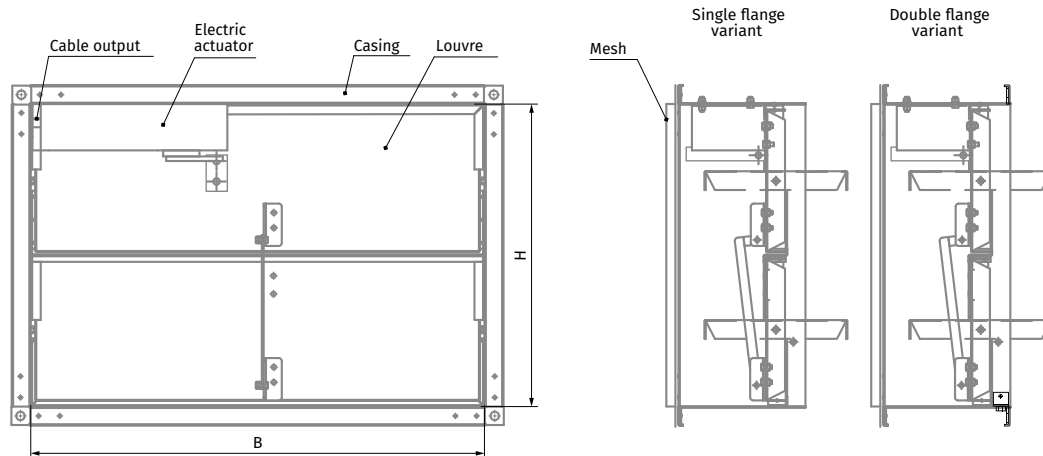

FLOW AREA OF THE RSKM SMOKE EXHAUST DAMPER WITH AN ELECTRIC ACTUATOR INSTALLED INSIDE THE DAMPER [m²]

B/H [mm]	300	350	400	450	500	550	600	650	700	750	800	850	900	950	1000
300	0.06														
350	0.08	0.10													
400	0.09	0.11	0.12												
450	0.10	0.13	0.14	0.16											
500	0.12	0.14	0.15	0.18	0.20										
550	0.13	0.16	0.17	0.20	0.23	0.25									
600	0.15	0.18	0.19	0.22	0.25	0.28	0.31								
650	0.16	0.19	0.20	0.24	0.27	0.30	0.33	0.37							
700	0.17	0.21	0.22	0.26	0.29	0.33	0.36	0.40	0.43						
750	0.19	0.22	0.24	0.28	0.31	0.35	0.39	0.43	0.46	0.48					
800	0.20	0.24	0.26	0.30	0.34	0.38	0.42	0.46	0.50	0.51	0.55				
850	0.21	0.26	0.27	0.31	0.36	0.40	0.44	0.48	0.53	0.54	0.59	0.63			
900	0.23	0.27	0.29	0.33	0.38	0.42	0.47	0.51	0.56	0.58	0.62	0.67	0.71		
950	0.24	0.29	0.31	0.35	0.40	0.45	0.50	0.54	0.59	0.61	0.66	0.71	0.75	0.80	
1000	0.25	0.30	0.32	0.37	0.42	0.47	0.52	0.57	0.62	0.64	0.69	0.74	0.79	0.84	0.89

Note: Select the damper of the required cross-section BxH according to the completed table cells. Since the damper can be installed in any spatial position, a change of the height and width (B and H values) orientation may enable selection of a damper with a cross-section beyond the completed cell range.

For example, a 700x500 mm damper can be ordered as 500x700 mm.

THE RSKM DAMPER WITH AN ELECTRIC ACTUATOR (230 OR 24 V) INSTALLED OUTSIDE THE DAMPER, SINGLE OR DOUBLE FLANGE

- o The single flange variant is intended for wall or ceiling mounting irrespective of the dimensional orientation.
- o The double flange variant is intended for duct installation irrespective of the dimensional orientation. The louvres of dampers equipped with a

two-position electric actuator are set to the "open" or "closed" position by an external actuating signal. After a test or emergency actuation the louvres of dampers equipped with an electric actuator with a return spring can return to the initial position automatically upon feeding the supply voltage.

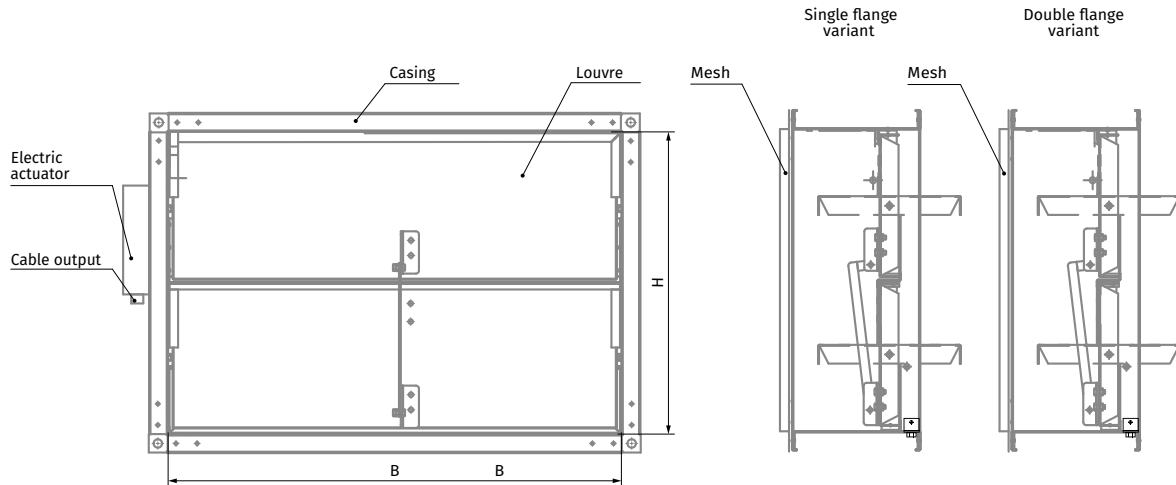

FLOW AREA OF THE RSKM SMOKE EXHAUST DAMPER WITH AN ELECTRIC ACTUATOR INSTALLED INSIDE THE DAMPER [M²]

B/H [mm]	300	350	400	450	500	550	600	650	700	750	800	850	900	950	1000
300	0.07														
350	0.09	0.11													
400	0.10	0.12	0.13												
450	0.11	0.14	0.15	0.17											
500	0.13	0.15	0.16	0.19	0.21										
550	0.14	0.17	0.18	0.21	0.24	0.26									
600	0.16	0.18	0.20	0.23	0.26	0.29	0.32								
650	0.17	0.20	0.21	0.25	0.28	0.31	0.34	0.38							
700	0.18	0.22	0.23	0.27	0.30	0.34	0.37	0.41	0.44						
750	0.20	0.23	0.25	0.29	0.32	0.36	0.40	0.44	0.47	0.49					
800	0.21	0.25	0.27	0.31	0.35	0.39	0.43	0.47	0.51	0.52	0.56				
850	0.22	0.27	0.28	0.32	0.37	0.41	0.45	0.49	0.54	0.55	0.60	0.64			
900	0.24	0.28	0.30	0.34	0.39	0.43	0.48	0.52	0.57	0.59	0.63	0.68	0.72		
950	0.25	0.30	0.32	0.36	0.41	0.46	0.51	0.55	0.60	0.62	0.67	0.72	0.76	0.81	
1000	0.26	0.31	0.33	0.38	0.43	0.48	0.53	0.58	0.63	0.65	0.70	0.75	0.80	0.85	0.90

Note: Select the damper of the required cross-section BxH according to the completed table cells. Since the damper can be installed in any spatial position, a change of the height and width (B and H values) orientation may enable selection of a damper with a cross-section beyond the completed cell range.

For example, a 700x500 mm damper can be ordered as 500x700 mm.

Possible RSKE damper variants

THE RSKE DAMPER WITH AN INTERNALLY INSTALLED ELECTROMAGNET (220/24 V), SINGLE OR DOUBLE FLANGE

- The single flange variant is intended for wall or ceiling installation. The damper must be installed according to the installation guidelines for the RSKE damper with an internal actuator (see page 14). Upon the test or emergency damper actuation, the louvres can only be manually reset to initial position.
- The double flange variant is intended for duct installation. Upon the test or emergency damper actuation the louvres can only be manually reset to the initial position.

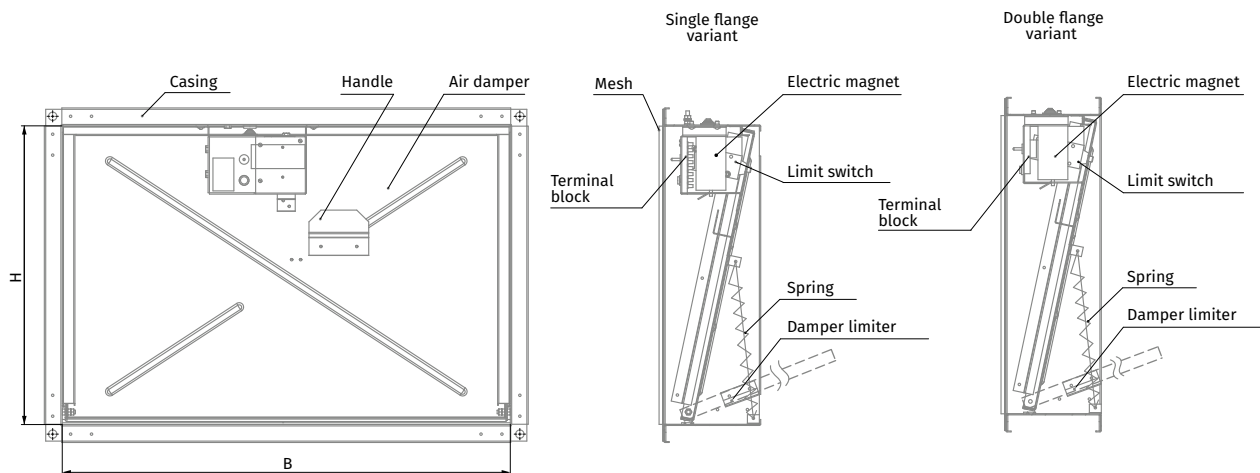

FLOW AREA OF THE RSKE SMOKE EXHAUST DAMPER WITH AN ELECTROMAGNET [m²]

B/H [mm]	300	350	400	450	500	550	600	650	700	750	800	850	900	950	1000
300	0.06														
350	0.08	0.10													
400	0.09	0.11	0.12												
450	0.10	0.13	0.14	0.16											
500	0.12	0.14	0.15	0.18	0.20										
550	0.13	0.16	0.17	0.20	0.23	0.25									
600	0.15	0.18	0.19	0.22	0.25	0.28	0.31								
650	0.16	0.19	0.20	0.24	0.27	0.30	0.33	0.37							
700	0.17	0.21	0.22	0.26	0.29	0.33	0.36	0.40	0.43						
750	0.19	0.22	0.24	0.28	0.31	0.35	0.39	0.43	0.46	0.48					
800	0.20	0.24	0.26	0.30	0.34	0.38	0.42	0.46	0.50	0.51	0.55				
850	0.21	0.26	0.27	0.31	0.36	0.40	0.44	0.48	0.53	0.54	0.59	0.63			
900	0.23	0.27	0.29	0.33	0.38	0.42	0.47	0.51	0.56	0.58	0.62	0.67	0.71		
950	0.24	0.29	0.31	0.35	0.40	0.45	0.50	0.54	0.59	0.61	0.66	0.71	0.75	0.80	
1000	0.25	0.30	0.32	0.37	0.42	0.47	0.52	0.57	0.62	0.64	0.69	0.74	0.79	0.84	0.89

Note: Select the damper of the required cross-section BxH according to the completed table cells.

THE RSKE DAMPER WITH AN ELECTRIC ACTUATOR (230 OR 24 V) INSTALLED INSIDE THE DAMPER, SINGLE OR DOUBLE FLANGE

- o The single flange variant is intended for wall or ceiling mounting irrespective of the dimensional orientation.
- o The double flange variant is intended for duct installation irrespective of the dimensional orientation. The louvres of dampers equipped with a

two-position electric actuator are set to the "open" or "closed" position by an external actuating signal. After a test or emergency actuation the louvres of dampers equipped with an electric actuator with a return spring can return to the initial position automatically upon feeding the supply voltage.

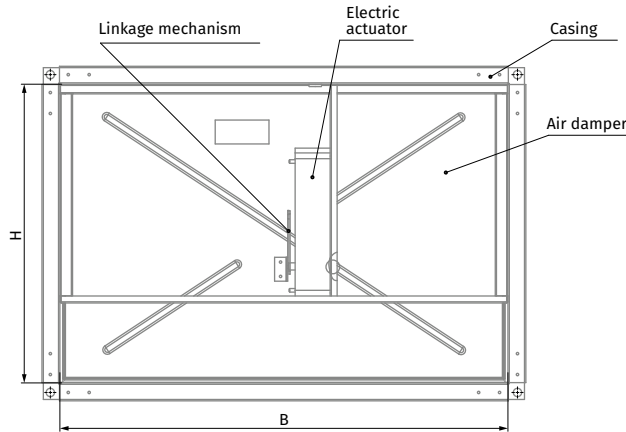

Single flange variant

Double flange variant

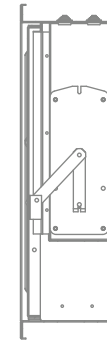
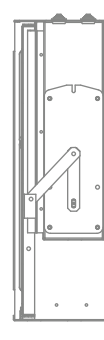

FLOW AREA OF THE RSKE SMOKE EXHAUST DAMPER WITH AN ELECTRIC ACTUATOR INSTALLED INSIDE THE DAMPER [m²]

B/H [mm]	300	350	400	450	500	550	600	650	700	750	800	850	900	950	1000
300	0.06														
350	0.08	0.10													
400	0.09	0.11	0.12												
450	0.10	0.13	0.14	0.16											
500	0.12	0.14	0.15	0.18	0.20										
550	0.13	0.16	0.17	0.20	0.23	0.25									
600	0.15	0.18	0.19	0.22	0.25	0.28	0.31								
650	0.16	0.19	0.20	0.24	0.27	0.30	0.33	0.37							
700	0.17	0.21	0.22	0.26	0.29	0.33	0.36	0.40	0.43						
750	0.19	0.22	0.24	0.28	0.31	0.35	0.39	0.43	0.46	0.48					
800	0.20	0.24	0.26	0.30	0.34	0.38	0.42	0.46	0.50	0.51	0.55				
850	0.21	0.26	0.27	0.31	0.36	0.40	0.44	0.48	0.53	0.54	0.59	0.63			
900	0.23	0.27	0.29	0.33	0.38	0.42	0.47	0.51	0.56	0.58	0.62	0.67	0.71		
950	0.24	0.29	0.31	0.35	0.40	0.45	0.50	0.54	0.59	0.61	0.66	0.71	0.75	0.80	
1000	0.25	0.30	0.32	0.37	0.42	0.47	0.52	0.57	0.62	0.64	0.69	0.74	0.79	0.84	0.89

Note: Select the damper of the required cross-section BxH according to the completed table cells. Since the damper can be installed in any spatial position, a change of the height and width (B and H values) orientation may enable selection of a damper with a cross-section beyond the completed cell range.

For example, a 700x500 mm damper can be ordered as 500x700 mm.

THE RSKE DAMPER WITH AN ELECTRIC ACTUATOR (230 OR 24 V) INSTALLED OUTSIDE THE DAMPER, SINGLE OR DOUBLE FLANGE:

- The single flange variant is intended for wall or ceiling mounting irrespective of the dimensional orientation.
- The double flange variant is intended for duct installation irrespective of the dimensional orientation. The louvres of dampers equipped with a two-position electric actuator are set to the "open" or "closed" position

by an external actuating signal. After a test or emergency actuation the louvres of dampers equipped with an electric actuator with a return spring can return to the initial position automatically upon feeding the supply voltage.

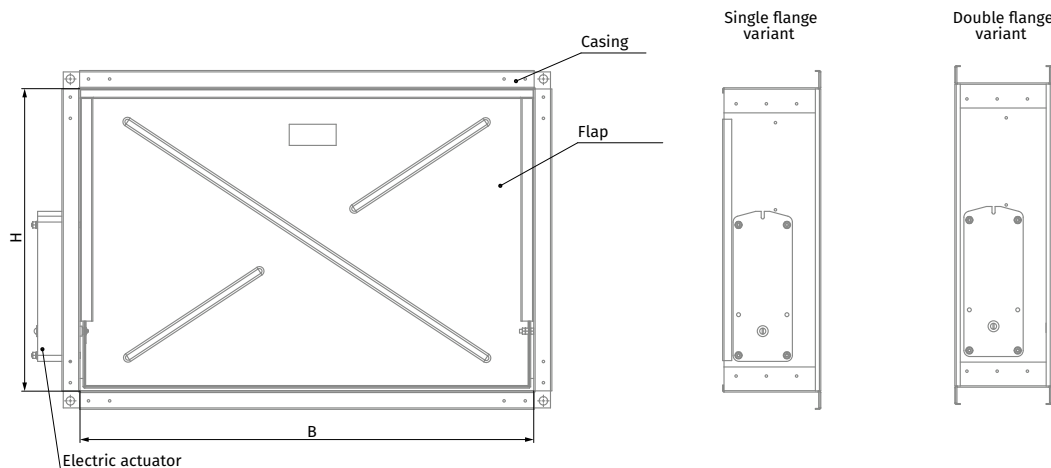

FLOW AREA OF THE RSKE SMOKE EXHAUST DAMPER WITH AN ELECTRIC ACTUATOR INSTALLED OUTSIDE THE DAMPER [m²]

B/H [mm]	300	350	400	450	500	550	600	650	700	750	800	850	900	950	1000
300	0.07														
350	0.09	0.11													
400	0.10	0.12	0.13												
450	0.11	0.14	0.15	0.17											
500	0.13	0.15	0.16	0.19	0.21										
550	0.14	0.17	0.18	0.21	0.24	0.26									
600	0.16	0.18	0.20	0.23	0.26	0.29	0.32								
650	0.17	0.20	0.21	0.25	0.28	0.31	0.34	0.38							
700	0.18	0.22	0.23	0.27	0.30	0.34	0.37	0.41	0.44						
750	0.20	0.23	0.25	0.29	0.32	0.36	0.40	0.44	0.47	0.49					
800	0.21	0.25	0.27	0.31	0.35	0.39	0.43	0.47	0.51	0.52	0.56				
850	0.22	0.27	0.28	0.32	0.37	0.41	0.45	0.49	0.54	0.55	0.60	0.64			
900	0.24	0.28	0.30	0.34	0.39	0.43	0.48	0.52	0.57	0.59	0.63	0.68	0.72		
950	0.25	0.30	0.32	0.36	0.41	0.46	0.51	0.55	0.60	0.62	0.67	0.72	0.76	0.81	
1000	0.26	0.31	0.33	0.38	0.43	0.48	0.53	0.58	0.63	0.65	0.70	0.75	0.80	0.85	0.90

Note: Select the damper of the required cross-section BxH according to the completed table cells. Since the damper can be installed in any spatial position, a change of the height and width (B and H values) orientation may enable selection of a damper with a cross-section beyond the completed cell range.

For example, a 700x500 mm damper can be ordered as 500x700 mm.

Technical data

ELECTROMAGNET

Parameters	Parameter value
Rated voltage [V]	220/24
Rated current at the ambient temperature of 25±10 °C [A]	0.6/5.5
Armature stroke [mm]	10±1
Armature release time [seconds]	2
Tractive force [N]	45
Maximum active power consumption at 220 V [W]	600
Maximum total power consumption at 220 V [W]	1200
Maximum total power consumption at 24 V [W]	60

BELIMO ELECTRIC ACTUATORS WITH A RETURN SPRING

Parameters	Basic models		Models with increased torque	
Rated voltage [V]	AC/DC 24	AC 230	AC/DC 24	AC 230
Rated voltage range [V]	AC 19.2...28.8 DC 21.6...28.8	AC 198...264	AC 19.2...28.8 DC 21.6...28.8	AC 198...264
Rated voltage frequency AC [Hz]	50/60		50/60	
Power consumption in rest position [W]	1.4	2.0	2	3
Power consumption in operation [W]	4.0	4.5	7	8.5
Maximum design capacity [VA]	6	9.0	10	11
Motor torque [Nm]	9		18	
Spring torque [Nm]	7		12	
Protection class	III	II	III	II
Ingress protection rating	IP54	IP54	IP54	IP54
Auxiliary switches	2 pcs., single-pole, reversible, 1 mA...3(0.5)A, AC 250 V		2 pcs., single-pole, reversible, 1 mA...6(3)A, AC 250 V	
Electric motor connection cable	1 m, 2 x 0.75 mm ² (halogen-free)			
Auxiliary switch connection cable	1 m, 6 x 0.75 mm ² (halogen-free)			
Running time spring	20 seconds at -10...+55 °C < 60 seconds at -30...-10 °C		16 seconds at +20 °C	
Running time motor	< 60 s/90°		< 120 s/90°	
Service life	Min. 60 000 emergency positions			
Technical maintenance	Not required			

BELIMO TWO-POSITION ELECTRIC ACTUATORS

Parameters	Basic models		Models with increased torque	
Rated voltage [V]	AC/DC 24	AC 230	AC/DC 24	AC 230
Rated voltage range [V]	AC 19.2...28.8 DC 21.6...28.8	AC 198...264	AC 19.2...28.8 DC 21.6...28.8	AC 198...264
Rated voltage frequency AC [Hz]	50/60		50/60	
Power consumption in rest position [W]	<0.5	<1	0.5	0.5
Power consumption in operation [W]	7,5	5	12	8
Maximum design capacity [VA]	9	12	18	15
Motor torque [Nm]	15		40	
Spring torque [Nm]	20		50	
Protection class	III	II	III	II
Ingress protection rating	IP54	IP54	IP54	IP54
Auxiliary switches	2 pcs., single-pole, reversible, 1 mA...3(0.5)A, AC 250 B			
Electric motor connection cable	1 m, 3 x 0.75 mm ² (halogen-free)			
Auxiliary switch connection cable	1 m, 6 x 0.75 mm ² (halogen-free)			
Running time	< 30 s/90°		< 60 s/90°	
Service life	Min. 10 000 emergency positions			
Technical maintenance	Not required			

ZERN ELECTRIC ACTUATORS WITH A RETURN SPRING

Parameters	Basic models		Models with increased torque	
Rated voltage [V]	AC/DC 24	AC 100–240	AC/DC 24	AC 100–240
Rated voltage range [V]	AC/DC 19.2...28.8	AC 85...265	AC/DC 19.2...28.8	AC 85...265
Rated voltage frequency AC [Hz]	50/60		50/60	
Power consumption in rest position [W]	3		3	
Power consumption in operation [W]	5		5	
Motor torque [Nm]	5		8	
Spring torque [Nm]	5		8	
Protection class	III	II	III	II
Ingress protection rating	IP54	IP54	IP54	IP54
Auxiliary switches	2 pcs., single-pole, reversible, 1 mA...3(0.5)A, AC 220 B 1 mA...3(0.5)A, AC 220 V			
Electric motor connection cable	1 m, 2 x 0.5 mm ² (halogen-free)			
Auxiliary switch connection cable	1 m, 6 x 0.5 mm ² (halogen-free)			
Running time spring	<20 seconds < 60 seconds at -30...-10 °C		<25 seconds < 60 seconds at -30...-10 °C	
Running time motor	< 70 s/95°		< 100 s/95°	

SIEMENS ELECTRIC ACTUATORS WITH A RETURN SPRING

Parameters	Basic models		Models with increased torque	
Rated voltage [V]	AC 24 / DC 24...48	AC 230	AC 24 / DC 24...48	AC 230
Rated voltage range [V]	AC/DC ±20 %	AC ±15 %	AC/DC ±20 %	AC ±15 %
Rated voltage frequency AC [Hz]	50/60		50/60	
Power consumption in rest position [W]	2	3.5	3	4
Power consumption in operation [W]	3.5	4.5	5	6
Maximum design capacity [VA]	5	7	7	8
Motor torque [Nm]	9		18	
Spring torque [Nm]	7		18	
Protection class	III	II	III	II
Ingress protection rating	IP54	IP54	IP54	IP54
Auxiliary switches	2 pcs., single-pole, reversible, 6(2)A, AC 24...250 V			
Electric motor connection cable	0.9 m, 2 x 0.75 mm ² (halogen-free)			
Auxiliary switch connection cable	0.9 m, 6 x 0.75 mm ² (halogen-free)			
Running time spring	15 seconds < 60 seconds at -30...-10 °C			
Running time motor	90 s/90°		90 s/90°	
Service life	10 000 emergency positions			
Technical maintenance	Not required			

Note: The table "Main technical specifications of Siemens two-position electric actuators" is in development. This information is available upon request.

Electrical connection diagrams of RSKE/RSKM dampers

RSKE/RSKM DAMPER EQUIPPED WITH AN ELECTROMAGNET

- SQ1:** end switch
- YA1:** electromagnet
- SB1:** damper louvre opening button
- PK:** contact of automatic fire suppression block
- SA1:** power supply circuit disconnection switch of electromagnetic latch
- X1:** terminal block

- 1:** supply voltage phase
- 2:** contact of automatic fire suppression block
- 3:** supply voltage neutral
- 4, 5:** command circuit control
- 6, 7:** louvre position control
- 8:** grounding bus

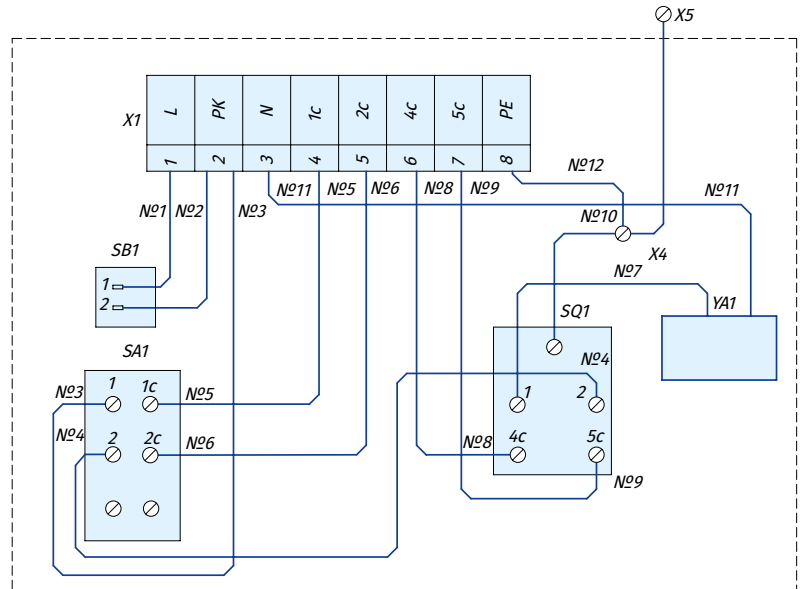

RSKE/RSKM DAMPER EQUIPPED WITH AN ELECTRIC ACTUATOR

Electric actuator with a return spring

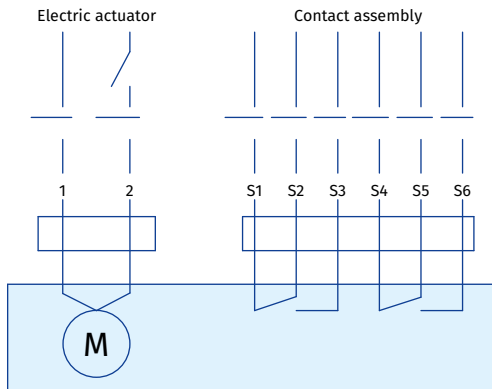

- 1:** "Neutral" contact of supply voltage
- 2:** "Line" contact of supply voltage – closing the damper louvres
- S1...S6:** fixed microswitch contacts for signalling end positions

Two-position electric actuator

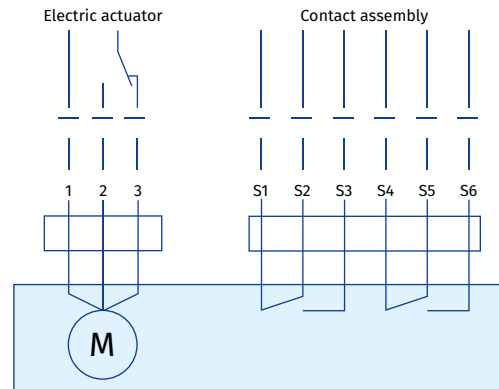

- 1:** "Neutral" contact of supply voltage
- 2, 3:** "Line" contact of supply voltage damper louvre closing or opening
- S1...S6:** fixed microswitch contacts for signalling end positions

Overall and connecting dimensions of RSKM multi-louvre dampers

Standard damper size [cm]	Minimum flow area [m ²]	Dimensions [mm]							Maximum RSKM weight [kg]
		H	H1	H2	B	B1	B2	L	
40x40	0.12	400	420	440	400	420	440	298	9.5
50x50	0.2	500	520	540	500	520	540	297	12.1
60x60	0.31	600	630	660	600	630	660	348	17
70x70	0.43	700	730	760	700	730	760	398	20.3
80x80	0.55	800	830	860	800	830	860	448	24.1
90x90	0.71	900	930	960	900	930	960	498	27.4
100x100	0.9	1000	1030	1060	1000	1030	1060	548	31.7

- o The **RSKM** damper with an internally installed electromagnet (220/24 V), single or double flange.

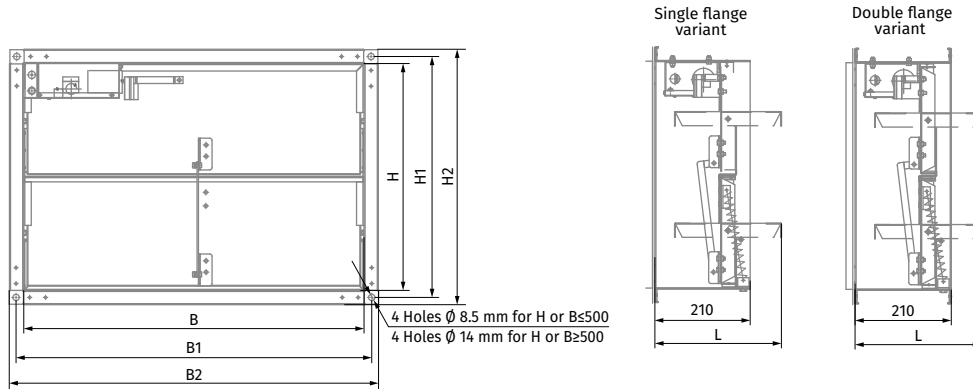

- o The **RSKM** damper with an electric actuator (230 or 24 V) installed inside the damper, single or double flange.

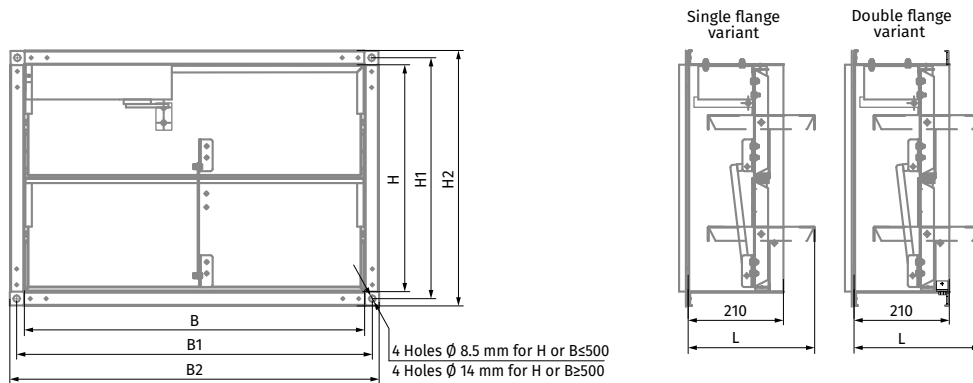

- o The **RSKM** damper with an electric actuator (230 or 24 V) installed outside the damper, single or double flange.

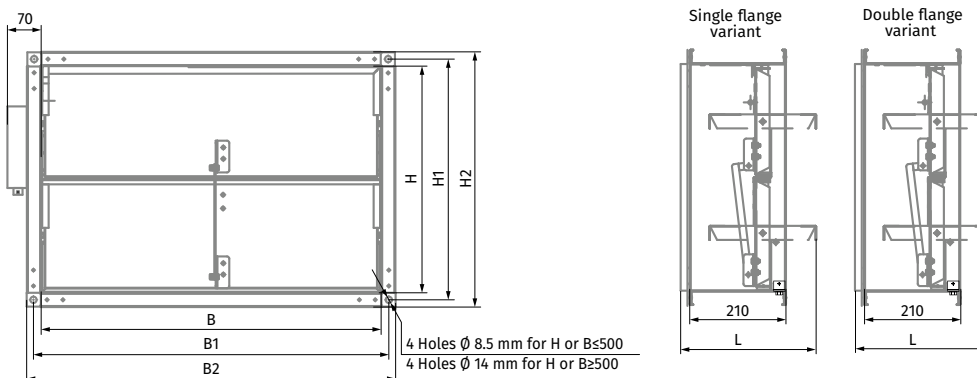

Overall and connecting dimensions of the RSKE single-louvre damper

Standard damper size [cm]	Minimum flow area [m ²]	Dimensions [mm]							Maximum RSKE weight [kg]
		H	H1	H2	B	B1	B2	L	
40x40	0.12	400	430	460	400	430	460	470	8.2
50x50	0.2	500	530	560	500	530	560	570	10.6
60x60	0.31	600	630	660	600	630	660	670	13.2
70x70	0.43	700	730	760	700	730	760	770	16
80x80	0.55	800	830	860	800	830	860	870	19
90x90	0.71	900	930	960	900	930	960	970	22.2
100 x100	0.9	1000	1030	1060	1000	1030	1060	1070	25.6

- The **RSKE** damper with an internally installed electromagnet (220/24 V), single or double flange.

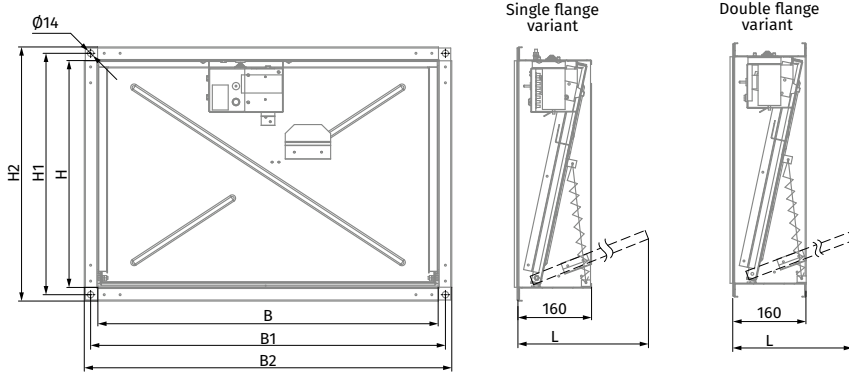

- The **RSKE** damper with an electric actuator (230 or 24 V) installed outside the damper, single or double flange.

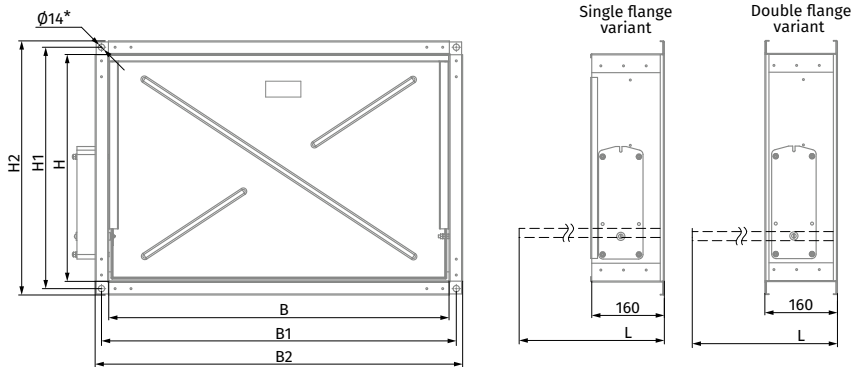

- The **RSKE** damper with an electric actuator (230 or 24 V) installed inside the damper, single or double flange.

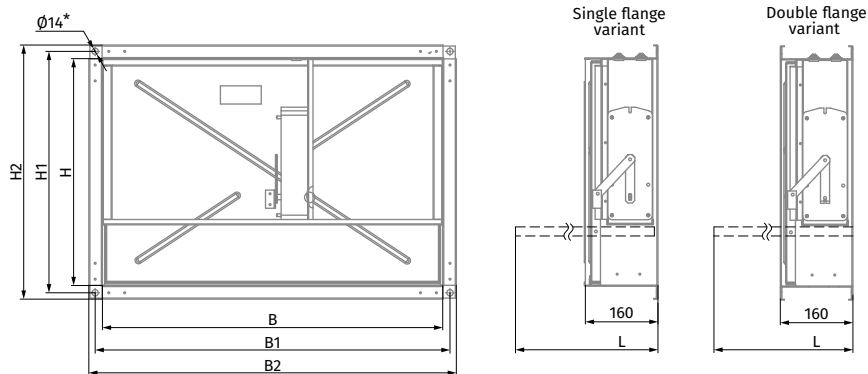

BSK1

Fire-resisting dampers

Use

- The fire-resisting dampers are intended for automatic closing of process openings and air duct penetrations in intermediate floors, walls and partitions, as well as closing of openings in supply and exhaust ducts of smoke ventilation systems.
- The dampers of this particular design are not suitable for installation in air ducts and ducts of premises with rated explosion and fire safety category A and B and in flammable and explosive mixture intakes.
- The **BSK1** fire-resisting duct dampers are capable of resisting fire for at least 60 minutes (EI 60) at the temperature of 600 °C.

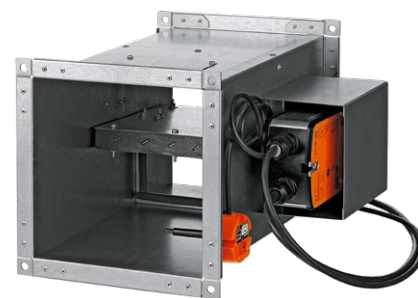

BSK1...PKP
BSK1...PVP
BSK1...PSP
normally open fire-resisting duct damper with electric drive mechanism.

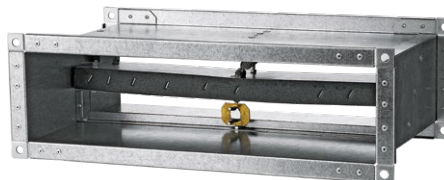

BSK1...72S
normally open fire-resisting duct damper with mechanical drive mechanism.

Design

- The **BSK1** series dampers are made in the general-purpose industrial version with a minimized variety of hardware components using low-alloy galvanized steel. The damper flap is made of fire-resistant material.
- The duct installation design results in two mounting flanges on the casing for integration into a ventilation duct (air ducting) and external configuration of the drive mechanism for easier maintenance.
- The **BSK1** series dampers are characterised by a simplified design and the absence of a hot and cold zone baffle.

Control and modifications

- Depending on the design variant BSK1 series dampers are equipped with:

MECHANICAL ACTUATING UNIT WITH A THERMAL FUSE AND A RETURN SPRING

- The damper is set to the operating position upon the thermal fuse breakdown resulting from a temperature increase.
- Emergency damper actuation: the flap remains in protective position (damper unaffected by fire) and is fixed by a thermal fuse (when the flap is installed in security position, a reverse spring is activated). Upon emergency actuation (damper directly affected by fire) the thermal fuse breaks down and the return spring moves the flap to operating position.

ELECTRIC ACTUATOR WITH A BUILT-IN RETURN SPRING AND A BACK-UP THERMAL BREAKER

- Setting the damper to operating position (direct fire contact): remotely, via an electric actuator. The damper can be set to the operating or protective position either remotely via a control panel or manually using a manual cocking handle which is always included in the standard delivery set of the electric actuator. In case of the remote control panel failure, the back-up thermal breaker interrupts the power supply to the electric actuator and the return spring sets the damper to the operating position.
- Emergency damper actuation: the damper flap is set to the protective position automatically (damper unaffected by fire). The electric actuator remains energized at all times.
- In case of an emergency actuation (direct fire contact), the electric actuator equipped with a return spring is de-energized and the damper flap is set to the operating position by means of the spring energy. In case of a power failure not related to fire and its subsequent restoration at the actuator with a return spring, the damper flap returns to protective position.

Designation key

BSK 1 20 x30 / 2 PVP24T / O

Series:
Fire-resisting damper

Fire resistance rating:
1: 1 hour

Damper flow area width [cm]:
20; 25; 30; 40; 50; 60; 80; 100

Damper flow area height [cm]:
20; 25; 30; 40; 50; 60; 80; 100

Number of flanges:
1: one
2: two

Actuator type:
72S: thermal fuse and return spring (manual actuation)
PKP24T: 24 V ZERN electric actuator with a return spring and a thermal breaker
PVP24T: 24 V BELIMO electric actuator with a return spring and a thermal breaker
PSP230T: 230 V BELIMO electric actuator with a return spring and a thermal breaker
PSP24T: 24 V SIEMENS electric actuator with a return spring and a thermal breaker
PSP230T: 230 V SIEMENS electric actuator with a return spring and a thermal breaker

Actuator location:
O: outside
I: inside (except for dampers with height or width less than 30 cm)

BSK1...72S FIRE SAFETY DAMPER WITH A MECHANICAL ACTUATING UNIT WITH A THERMAL FUSE AND A RETURN SPRING

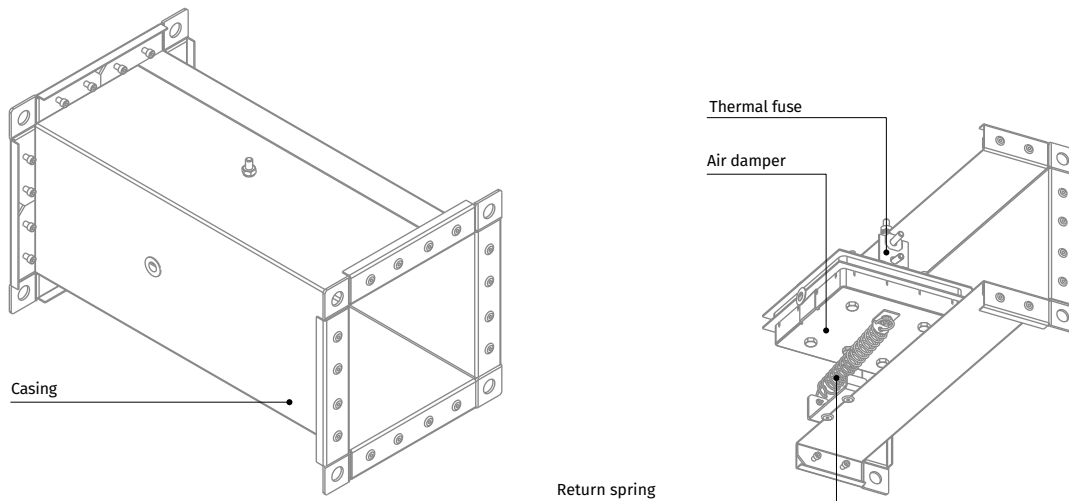

BSK1...PKP/BSK1...PVP/BSK1...PSP FIRE SAFETY DAMPER WITH A BELIMO ELECTRIC ACTUATOR AND A THERMOELECTRIC BREAKER

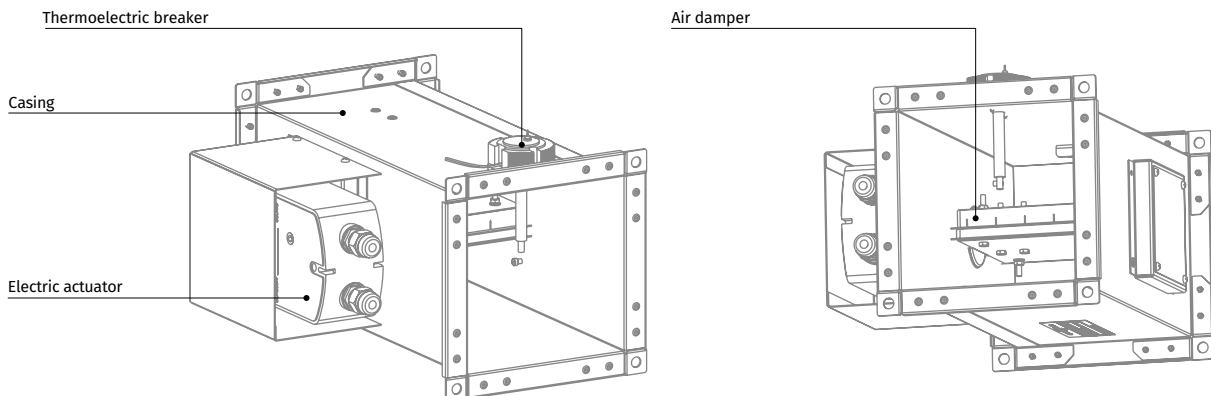

Mounting

- The damper must be installed into the building envelope structure in accordance with the applicable standards and regulations. The seal fire resistance must be at least equal to that of the building envelope.
- The dampers can be installed in any position in vertical and horizontal ducts of fire-protection structures. The ducts for damper installation must be made in such a way so as to prevent the transfer of loads caused by the fire-protection structures to the damper casing. The adjoining air duct must be suspended in such a way so as to prevent the transfer of air duct load to the damper flange. The minimum free space for accessing the control parts must be at least 350 mm. Make sure to arrange an inspection hole. While carrying out the installation consider size K. When two or more dampers are installed into the same fire-protection separation structure, the distance between the two adjacent dampers must be at least 200 mm.
- The damper must be installed in such a way that the damper flap (in its closed position) lies in the fire-protection divider structure plane. If such installation is not possible, the damper casing part between the fire-protection separation structure and the damper flap must be insulated with a suitable material pursuant to the applicable standards.
- The damper control mechanism must be protected against damage and contamination. The damper casing must not deform any deformation during embedding. After the installation the flap must not catch against the damper casing while opening or closing. The fire safety damper can be integrated into a tight wall structure - e.g. made of conventional concrete work of minimum width $W = 100$ mm or into a plasterboard wall of the necessary fire resistance class or into a tight ceiling structure - e.g. made of conventional concrete of minimum width $W = 150$ mm. Do not use any foaming substances for sealing the damper in the separation structure.

INSTALLATION RECOMMENDATIONS FOR BSK1...72S DAMPERS WITH THERMAL FUSE AND RETURN SPRING:

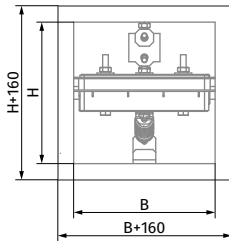

For Sizes B and H please refer to the dimension table

IN VERTICAL BUILDING STRUCTURES

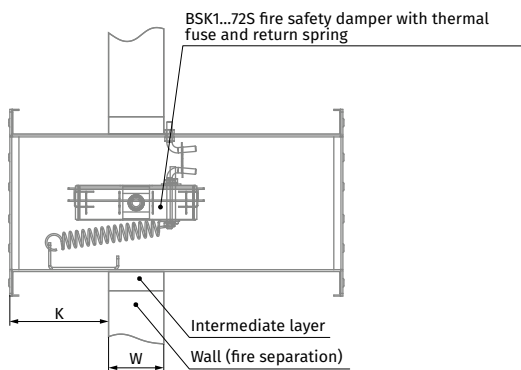

IN HORIZONTAL BUILDING STRUCTURES

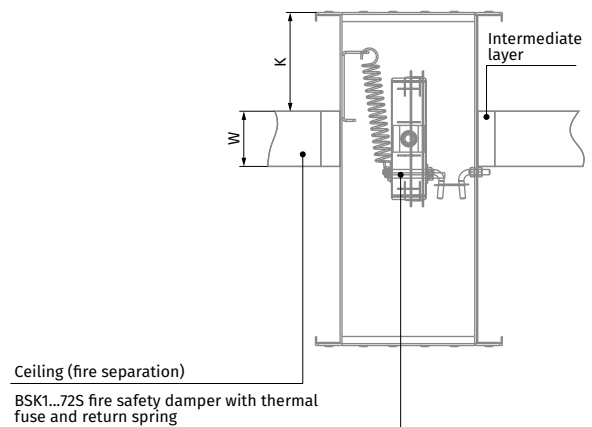

DUCT MODIFICATION WITH AN AIR DUCT

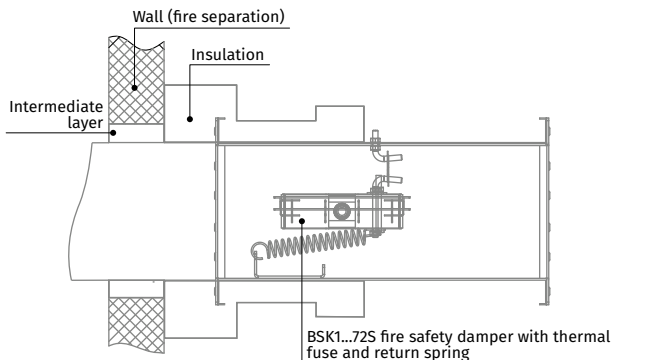

INSTALLATION RECOMMENDATIONS FOR BSK1...PKP/BSK1...PVP/BSK1...PSP FIRE SAFETY DAMPERS WITH ELECTRIC ACTUATOR AND THERMOELECTRIC BREAKER

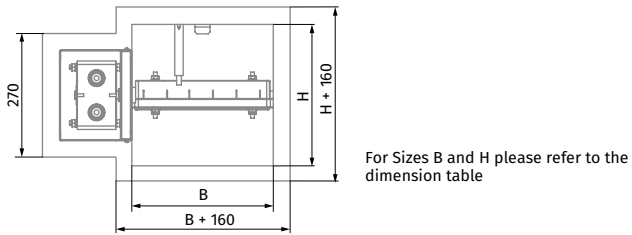

IN VERTICAL BUILDING STRUCTURES

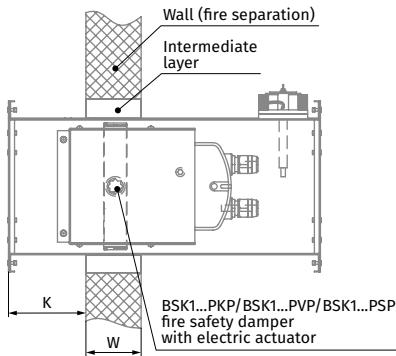

IN HORIZONTAL BUILDING STRUCTURES

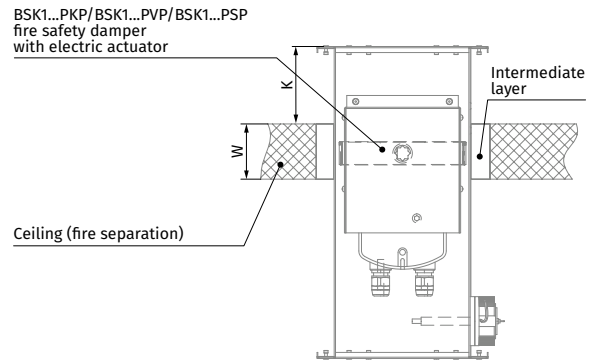

DUCT MODIFICATION WITH AN AIR DUCT

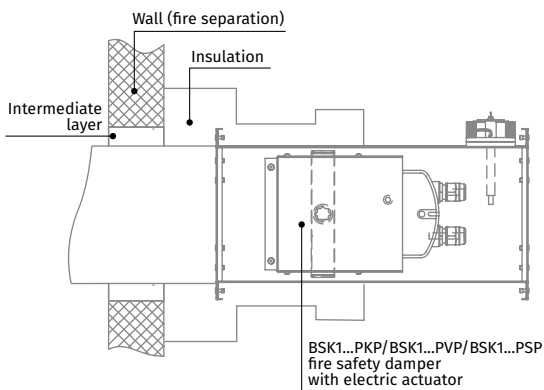

Overall and connecting dimensions

BSK1...72S DAMPERS WITH MECHANICAL ACTUATOR

Duct cross-section	Dimensions [mm]						Weight [kg]
	B	B1	B2	H	H1	H2	
BSK1 20x20/2 72S/O O	200	220	240	200	220	240	3.5
BSK1 25x20/2 72S/O O	250	270	290	200	220	240	4
BSK1 25x25/2 72S/O O	250	270	290	250	270	290	4.5
BSK1 30x20/2 72S/O O	300	320	340	200	220	240	4.5
BSK1 30x25/2 72S/O O	300	320	340	250	270	290	5.1
BSK1 30x30/2 72S/O O	300	320	340	300	320	340	5.8
BSK1 40x25/2 72S/O O	400	420	440	250	270	290	6.3
BSK1 40x30/2 72S/O O	400	420	440	300	320	340	7.1
BSK1 40x40/2 72S/O O	400	420	440	400	420	440	8.7
BSK1 50x30/2 72S/O O	500	520	540	300	320	340	8.5
BSK1 50x40/2 72S/O O	500	520	540	400	420	440	10.3
BSK1 50x50/2 72S/O O	500	520	540	500	520	540	12
BSK1 60x40/2 72S/O O	600	620	640	400	420	440	11.9
BSK1 60x50/2 72S/O O	600	620	640	500	520	540	13.8
BSK1 60x60/2 72S/O O	600	620	640	600	620	640	16.1

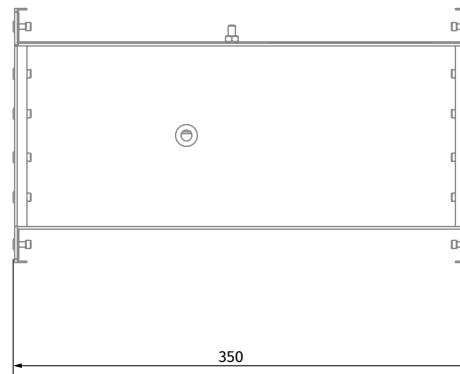
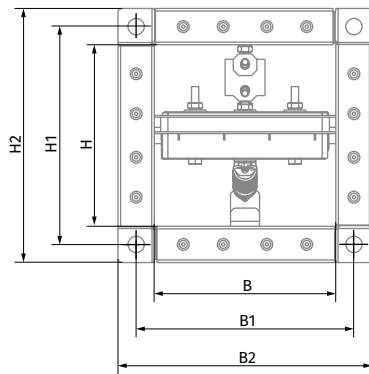

FLOW AREA OF FIRE-RESISTING DUCT DAMPER WITH MECHANICAL ACTUATOR [m²]

B/H [mm]	200	250	300	400	500	600
200	0.032					
250	0.04	0.053				
300	0.048	0.063	0.078			
400	0.064	0.084	0.104	0.144		
500	0.08	0.105	0.13	0.18	0.23	
600	0.096	0.126	0.156	0.216	0.276	0.336

Dampers with dimensions not included in the table can be produced on request.
Limit damper size: 600x600 mm

Overall and connecting dimensions

BSK1...PKP/BSK1...PVP/BSK1...PSP DAMPERS WITH ELECTRIC ACTUATORS

Duct cross-section	Dimensions [mm]							Weight [kg]
	B	B1	B2	B3	H	H1	H2	
BSK1 20x20/2 .../O O	200	220	240	325	200	220	240	6.2
BSK1 25x20/2 .../O O	250	270	290	375	200	220	240	6.8
BSK1 25x25/2 .../O O	250	270	290	375	250	270	290	7.3
BSK1 30x20/2 .../O O	300	320	340	425	200	220	240	7.3
BSK1 30x25/2 .../O O	300	320	340	425	250	270	290	7.9
BSK1 30x30/2 .../O O	300	320	340	425	300	320	340	8.5
BSK1 40x25/2 .../O O	400	420	440	525	250	270	290	9.1
BSK1 40x30/2 .../O O	400	420	440	525	300	320	340	9.8
BSK1 40x40/2 .../O O	400	420	440	525	400	420	440	11.3
BSK1 50x30/2 .../O O	500	520	540	625	300	320	340	10.7
BSK1 50x40/2 .../O O	500	520	540	625	400	420	440	12.9
BSK1 50x50/2 .../O O	500	530	560	635	500	530	560	16.6
BSK1 60x40/2 .../O O	600	620	640	725	400	420	440	14.5
BSK1 60x50/2 .../O O	600	630	660	735	500	530	560	18.4
BSK1 60x60/2 .../O O	600	630	660	735	600	630	660	20.6
BSK1 80x50/2 .../O O	800	830	860	935	500	530	560	22.3
BSK1 80x60/2 .../O O	800	830	860	935	600	630	660	24.8
BSK1 80x80/2 .../O O	800	830	860	935	800	830	860	30.1
BSK1 100x60/2 .../O O	1000	1030	1060	1135	600	630	660	29
BSK1 100x80/2 .../O O	1000	1030	1060	1135	800	830	860	35.4
BSK1 100x100/2 .../O O	1000	1030	1060	1135	1000	1030	1060	41.7

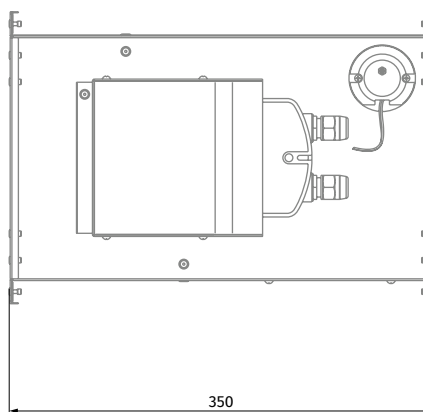
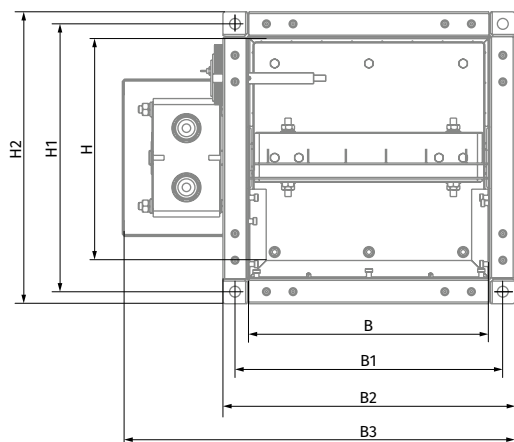

Note: The values given in the table for dampers with 230 V actuators are identical for those equipped with 24 V actuators.

FIRE SAFETY DAMPERS

FLOW AREA OF THE DUCT FIRE-RESISTANT DAMPER WITH AN ELECTRIC ACTUATOR INSTALLED OUTSIDE THE DAMPER [M²]

B/H [mm]	200	250	300	400	500	600	800	1000
200	0.032							
250	0.04	0.053						
300	0.048	0.063	0.078					
400	0.064	0.084	0.104	0.144				
500	0.08	0.105	0.13	0.18	0.23			
600	0.096	0.126	0.156	0.216	0.276	0.336		
800	0.128	0.168	0.208	0.288	0.368	0.448	0.608	
1000	0.16	0.21	0.26	0.36	0.46	0.56	0.76	0.96

Dampers with dimensions not included in the table can be produced on request.
Limit damper size: 1000x1000 mm

Technical data
BELIMO ELECTRIC ACTUATORS WITH A RETURN SPRING AND A THERMAL BREAKER

Parameters	Basic models		Models with increased torque		Models with the highest torque	
Rated voltage [V]	AC/DC 24	AC 230	AC/DC 24	AC 230	AC/DC 24	AC 230
Rated voltage range [V]	AC 19.2...28.8 DC 21.6...28.8	AC 198...264	AC 19.2...28.8 DC 21.6...28.8	AC 198...264	AC 19.2...28.8 DC 21.6...28.8	AC 198...264
Rated voltage frequency AC [Hz]	50/60		50/60		50/60	
Power consumption in rest position [W]	0.8	1.1	1.4	2.1	2	3
Power consumption in operation [W]	2.5	3.5	4	5	7	8.5
Maximum design capacity [VA]	4	6.5	6	10	10	11
Motor torque [Nm]	4		9		18	
Spring torque [Nm]	3		7		12	
Protection class	III	II	III	II	III	II
Ingress protection rating	IP54	IP54	IP54	IP54	IP54	IP54
Auxiliary switches	2 pcs., single-pole, reversible, 1 mA...3(0,5)A, AC 250 V				2 pcs., single-pole, reversible, 1 mA...6(3)A, AC 250 V	
Electric motor connection cable	1 m, 2 x 0.75 mm ² (halogen-free)					
Auxiliary switch connection cable	1 m, 6 x 0.75 mm ² (halogen-free)					
Running time spring	20 seconds at -10...+55 °C < 60 seconds at -30...-10 °C		20 seconds at -10...+55 °C < 60 seconds at -30...-10 °C		16 seconds at +20 °C	
Running time motor	< 60 s/90°		< 60 s/90°		< 120 s/90°	
Response temperature of thermal breaker sensors	Duct sensor 72 °C Outdoor sensor 72 °C					
Service life	Min. 60 000 emergency positions					
Technical maintenance	Not required					

ZERN ELECTRIC ACTUATORS WITH A RETURN SPRING AND A THERMAL BREAKER

Parameters	Basic models		Models with increased torque	
Rated voltage [V]	AC/DC 24	AC 100–240	AC/DC 24	AC 100–240
Rated voltage range [V]	AC/DC 19.2...28.8	AC 85...265	AC/DC 19.2...28.8	AC 85...265
Rated voltage frequency AC [Hz]	50/60		50/60	
Power consumption in rest position [W]	3		3	
Power consumption in operation [W]	5		5	
Motor torque [Nm]	5		8	
Spring torque [Nm]	5		8	
Protection class	III	II	III	II
Ingress protection rating	IP54	IP54	IP54	IP54
Auxiliary switches	2 pcs., single-pole, reversible, 1 mA...3(0,5)A, AC 220 V			
Electric motor connection cable	1 m, 2 x 0.5 mm ² (halogen-free)			
Auxiliary switch connection cable	1 m, 6 x 0.5 mm ² (halogen-free)			
Running time spring	<20 seconds < 60 seconds at -30...-10 °C		<25 seconds < 60 seconds at -30...-10 °C	
Running time motor	< 70 s/95°		< 100 s/95°	
Response temperature of thermal breaker sensors	Duct sensor 72 °C Outdoor sensor 72 °C			

SIEMENS ELECTRIC ACTUATORS WITH A RETURN SPRING AND A THERMAL BREAKER

Parameters	Basic models		Models with increased torque		Models with the highest torque	
Rated voltage [V]	AC 24/ DC 24...48	AC 230	AC 24/ DC 24...48	AC 230	AC 24/ DC 24...48	AC 230
Rated voltage range [V]	AC/DC ±20 %	AC ±15 %	AC/DC ±20 %	AC ±15 %	AC/DC ±20 %	AC ±15 %
Rated voltage frequency AC [Hz]	50/60		50/60		50/60	
Power consumption in rest position [W]	2	3.5	2	3.5	3	4
Power consumption in operation [W]	3.5	4.5	3.5	4.5	5	6
Maximum design capacity [VA]	5	7	5	7	7	8
Motor torque [Nm]	4		9		18	
Spring torque [Nm]	4		7		18	
Protection class	III	II	III	II	III	II
Ingress protection rating	IP54	IP54	IP54	IP54	IP54	IP54
Auxiliary switches	2 pcs., single-pole, reversible, 6(2)A, AC 24...250 V					
Electric motor connection cable	0.9 m, 2 x 0.75 mm ² (halogen-free)					
Auxiliary switch connection cable	0.9 m, 6 x 0.75 mm ² (halogen-free)					
Running time spring	15 seconds < 60 seconds at -30...-10 °C					
Running time motor	90 s/90°					
Response temperature of thermal breaker sensors	Duct sensor 72 °C Outdoor sensor 72 °C					
Service life	10 000 emergency positions					
Technical maintenance	Not required					

Electrical connection

BASIC MODELS OF BELIMO AND ZERN ELECTRIC ACTUATORS. BELIMO AND ZERN MODELS WITH INCREASED TORQUE

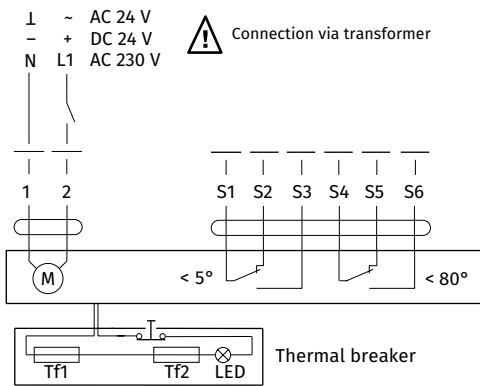

BELIMO ELECTRIC ACTUATORS WITH THE HIGHEST TORQUE, SIEMENS ELECTRIC ACTUATORS

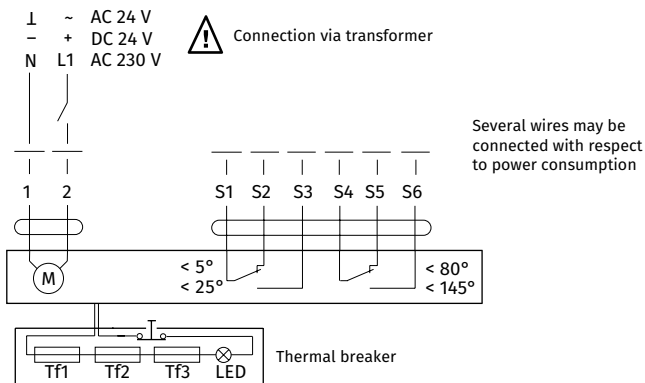

BSK2

Fire-resisting dampers

Use

- The fire-resisting dampers are intended for automatic closing of process openings and air duct penetrations in intermediate floors, walls and partitions, as well as closing of openings in supply and exhaust ducts of smoke ventilation systems. The dampers of this particular design are not suitable for installation in air ducts and ducts of premises with rated explosion and fire safety category A and B and in flammable and explosive mixture intakes. The **BSK2** fire-resisting duct dampers are capable of resisting fire for at least 120 minutes (EI 120) at the temperature of 600 °C.

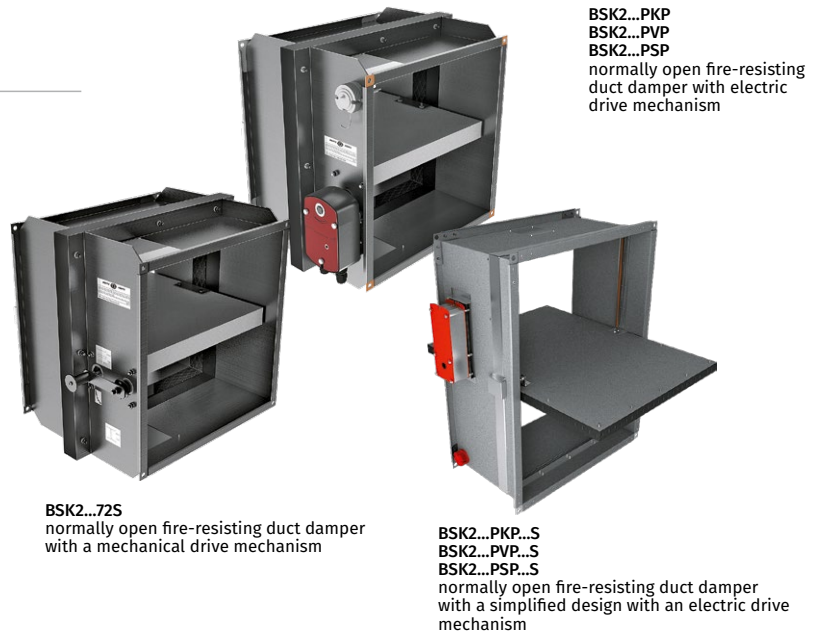

BSK2...72S
normally open fire-resisting duct damper with a mechanical drive mechanism

BSK2...PKP
BSK2...PVP
BSK2...PSP
normally open fire-resisting duct damper with electric drive mechanism

Design

- The **BSK2** series dampers are made in the general-purpose industrial version with a minimized variety of hardware components using low-alloy galvanized steel. The damper flap is made of fire-resistant material.
- The duct installation design results in two mounting flanges on the casing for integration into a ventilation ducts (air ducting) and external configuration of the drive mechanism for easier maintenance.
- The **BSK2...PKP/ BSK2...PVP/ BSK2...PSP** dampers are equipped with a hot and cold zone baffle.
- The **BSK2...PKP...S/ BSK2...PVP...S/ BSK2...PSP...S** dampers have a simplified construction:
 - Simplified damper swing mechanism
 - The zone baffle has been replaced by casing perforation covered with ceramic fibre material and aluminium foil tape
 - New material and altered flap thickness.

Control and modifications

- Depending on the design variant the **BSK2** series dampers are equipped with:

MECHANICAL ACTUATING UNIT WITH A THERMAL FUSE AND A RETURN SPRING

- The damper is set to the operating position upon the thermal fuse breakdown resulting from a temperature increase. The damper can then be re-set to the protective position only manually by using a handle and by replacing the thermal fuse through the access hole.
- Emergency damper actuation: the flap remains in protective position (damper unaffected by fire) and is fixed by a thermal fuse (when the flap is installed in security position, a reverse spring is activated). Upon emergency actuation (damper directly affected by fire) the thermal fuse breaks down and the return spring moves the flap to operating position.

ELECTRIC ACTUATOR WITH A BUILT-IN RETURN SPRING AND A BACK-UP THERMAL BREAKER

- Setting the damper to operating position (direct fire contact): remotely, via electric actuator. The damper can be set to the operating or protective position either remotely via the control panel or manually using the manual cocking handle which is always included in the standard delivery set of the electric actuator.
- In case of the remote control panel failure, the back-up thermal breaker interrupts the power supply to the electric actuator and the return spring sets the damper to the operating position.
- Emergency damper actuation: The damper flap is set to the protective position automatically (damper unaffected by fire). The electric actuator remains energized at all times.
- In case of an emergency actuation (direct fire contact), the electric actuator equipped with a return spring is de-energized and the damper flap is set to the operating position by means of the spring energy. In case of a power failure not related to fire and its subsequent restoration at the actuator with a return spring, the damper flap returns to protective position.

Designation key

BSK 2 20x30 / 2 PVP24T / O S

Series:
Fire-resisting damper

Fire resistance:
2: 2 hours

Damper flow area width [cm]:
20; 25; 30; 40; 50; 60; 80; 100

Damper flow area height [cm]:
20; 25; 30; 40; 50; 60; 80; 100

Number of flanges:
1: one
2: two

Actuator type:
72S: thermal fuse and return spring (manual actuation)
PKP24T: 24 V ZERN electric actuator with a return spring and a thermal breaker
PKP230T: 230 V ZERN electric actuator with a return spring and a thermal breaker
PVP24T: 24 V BELIMO electric actuator with a return spring and a thermal breaker
PVP230T: 230 V BELIMO electric actuator with a return spring and a thermal breaker
PSP24T: 24 V SIEMENS electric actuator with a return spring and a thermal breaker
PSP230T: 230 V SIEMENS electric actuator with a return spring and a thermal breaker

Actuator location:
O: outside
I: inside (except for dampers with height or width less than 30 cm)

Design variant:
_: ordinary damper design
S: simplified damper design

THE BSK2...72S FIRE SAFETY DAMPER WITH A MECHANICAL ACTUATING UNIT WITH A THERMAL FUSE AND A RETURN SPRING

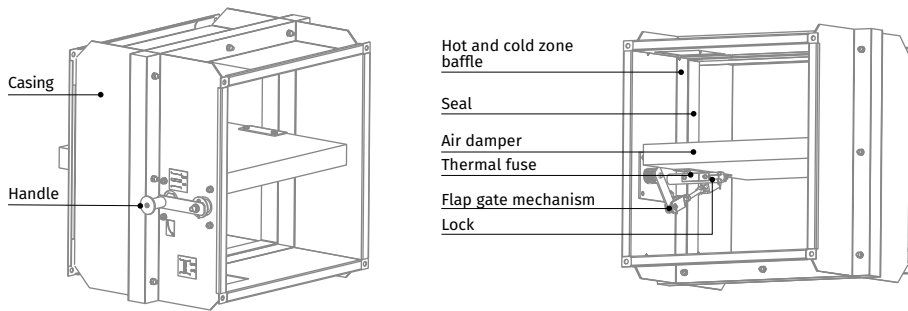

THE BSK2...PKP/BSK2...PVP/BSK2...PSP FIRE SAFETY DAMPER WITH ELECTRIC ACTUATOR AND THERMOELECTRIC BREAKER

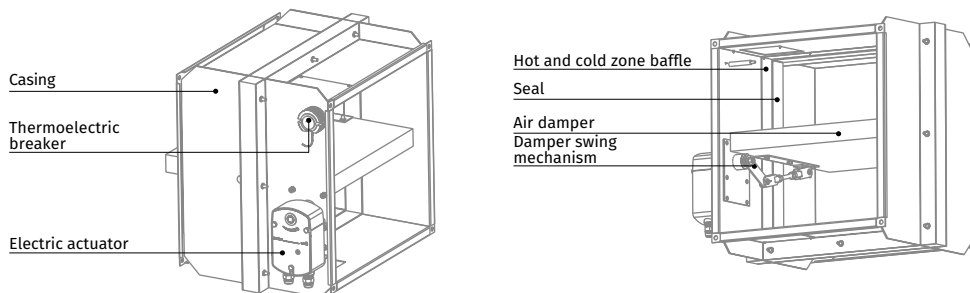

THE BSK2...PKP...S/BSK2...PVP...S/BSK2...PSP...S FIRE SAFETY DAMPER WITH BELIMO ELECTRIC ACTUATOR AND THERMOELECTRIC BREAKER

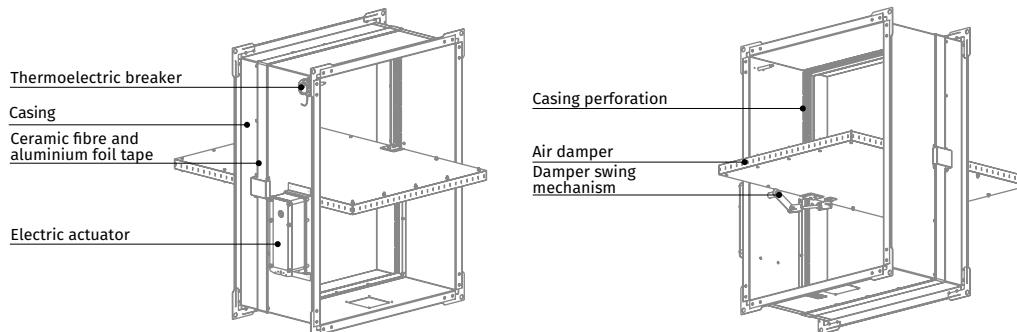

Mounting

- The damper must be installed into the building envelope structure in accordance with the applicable standards and regulations. The seal fire resistance must be at least equal to that of the building envelope.
- The dampers can be installed in any position in vertical and horizontal ducts of fire-protection structures. The ducts for damper installation must be made in such a way so as to prevent the transfer of loads caused by the fire-protection structures to the damper casing. The adjoining air duct must be suspended in such a way so as to prevent the transfer of air duct load to the damper flange. The minimum free space for accessing the control parts must be at least 350 mm. Make sure to arrange an inspection hole. While carrying out the installation consider size K. When two or more dampers are installed into the same fire-protection separation structure, the distance between the two adjacent dampers must be at least 200 mm.
- If such installation is not possible, the damper casing part between the fire-protection separation space and the damper flap must be insulated with a suitable material pursuant to the applicable standards. If such installation is not possible, the damper casing part between the fire-protection separation structure and the damper flap must be insulated with a suitable material pursuant to the applicable standards.
- The damper casing must not deform any deformation during embedding. After the installation the flap must not catch against the damper casing while opening or closing. The fire safety damper can be integrated into a tight wall structure – e.g. made of conventional concrete work of minimum width $W = 100$ mm or into a plasterboard wall of the necessary fire resistance class or into a tight ceiling structure – e.g. made of conventional concrete of minimum width $W = 150$ mm. Do not use any foaming substances for sealing the damper in the separation structure.

INSTALLATION RECOMMENDATIONS FOR BSK2...72S DAMPERS WITH THERMAL FUSE AND RETURN SPRING

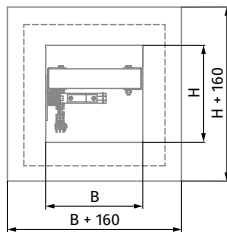

For Sizes B and H please refer to the dimension table

IN VERTICAL BUILDING STRUCTURES

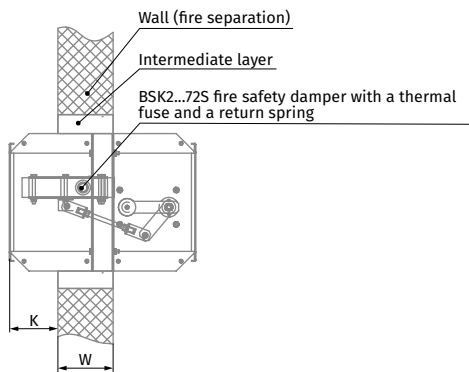

IN HORIZONTAL BUILDING STRUCTURES

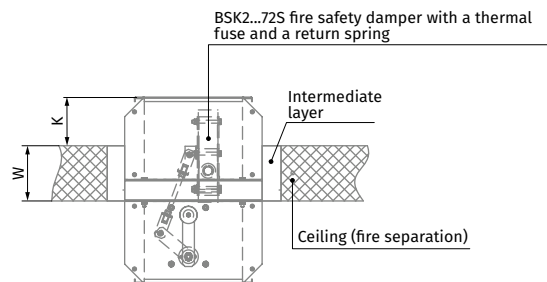

INSTALLATION RECOMMENDATIONS FOR BSK2...PKP/ BSK2...PVP/ BSK2...PSP FIRE SAFETY DAMPERS WITH AN ELECTRIC ACTUATOR AND THERMOELECTRIC BREAKER

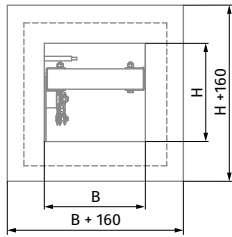

For Sizes B and H please refer to the dimension table

IN HORIZONTAL BUILDING STRUCTURES

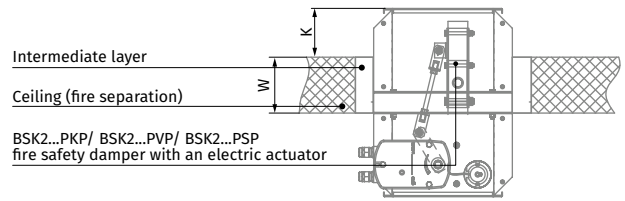

IN VERTICAL BUILDING STRUCTURES

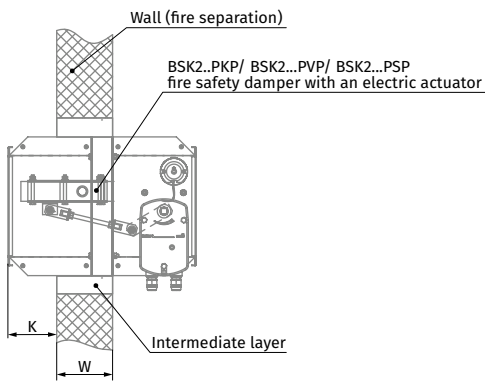

DUCT MODIFICATION WITH AN AIR DUCT

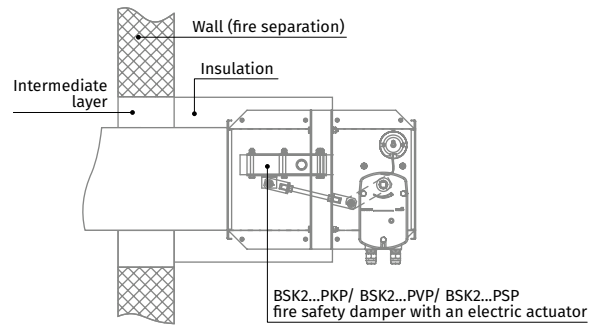

INSTALLATION RECOMMENDATIONS FOR BSK2...PKP...S/ BSK2...PVP...S/BSK2...PSP...S FIRE SAFETY DAMPERS WITH AN ELECTRIC ACTUATOR AND THERMOELECTRIC BREAKER

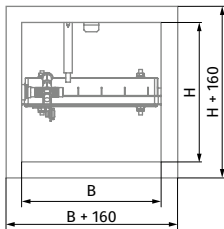

For Sizes B and H please refer to the dimension table

IN VERTICAL BUILDING STRUCTURES

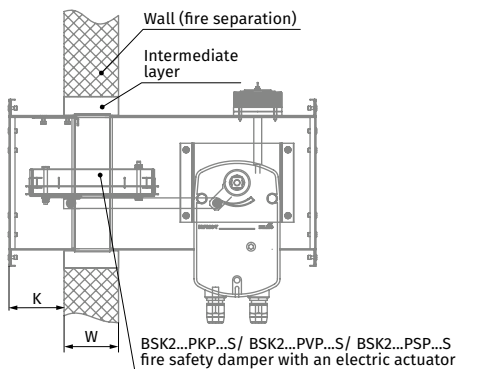

DUCT MODIFICATION WITH AN AIR DUCT

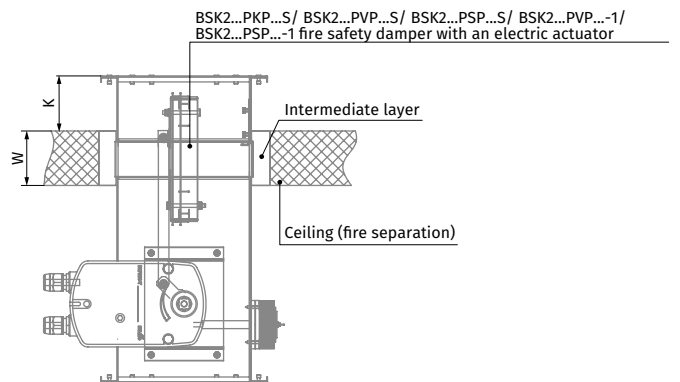

Overall and connecting dimensions

BSK2...72S DAMPERS WITH A MECHANICAL ACTUATOR

Duct cross-section	Dimensions [mm]									Weight [kg]
	B	B1	B2	B3	H	H1	H2	H3	S	
BSK2 20x20/2 72S/O O	200	220	240	280	200	220	240	280	315	12
BSK2 25x20/2 72S/O O	250	270	290	330	200	220	240	280	365	13
BSK2 25x25/2 72S/O O	250	270	290	330	250	270	290	330	365	14.1
BSK2 30x20/2 72S/O O	300	320	340	380	200	220	240	280	415	14
BSK2 30x25/2 72S/O O	300	320	340	380	250	270	290	330	415	15.3
BSK2 30x30/2 72S/O O	300	320	340	380	300	320	340	380	415	18.8
BSK2 40x25/2 72S/O O	400	420	440	480	250	270	290	330	515	19.2
BSK2 40x30/2 72S/O O	400	420	440	480	300	320	340	380	515	19.7
BSK2 40x40/2 72S/O O	400	420	440	480	400	420	440	480	515	22
BSK2 50x30/2 72S/O O	500	520	540	580	300	320	340	380	615	22.5
BSK2 50x40/2 72S/O O	500	520	540	580	400	420	440	480	615	24.7
BSK2 50x50/2 72S/O O	500	520	540	580	500	520	540	580	615	29.8
BSK2 60x40/2 72S/O O	600	620	640	680	400	420	440	480	715	29.7
BSK2 60x50/2 72S/O O	600	620	640	680	500	520	540	580	715	36
BSK2 60x60/2 72S/O O	600	620	640	680	600	620	640	680	715	38

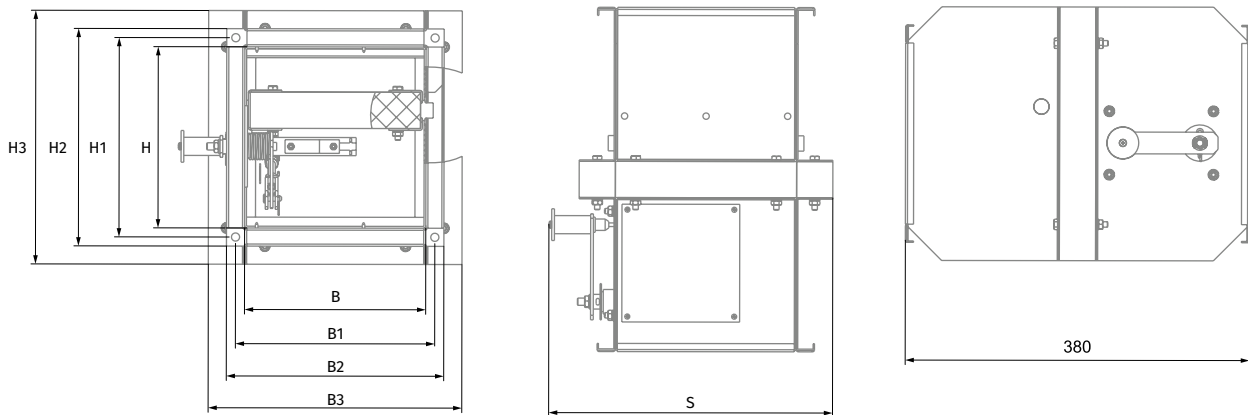

FLOW AREA OF FIRE-RESISTING DUCT DAMPER WITH MECHANICAL ACTUATOR [m²]

B/H [mm]	200	250	300	400	500	600
200	0.032					
250	0.04	0.053				
300	0.048	0.063	0.078			
400	0.064	0.084	0.104	0.144		
500	0.08	0.105	0.13	0.18	0.23	
600	0.096	0.126	0.156	0.216	0.276	0.336

Dampers with dimensions not included in the table can be produced on request.
Limit damper size: 600x600 mm.

Overall and connecting dimensions

BSK2...PKP/BSK2...PVP/BSK2...PSP DAMPERS WITH ELECTRIC ACTUATORS

Duct cross-section	Dimensions [mm]									Weight [kg]
	B	B1	B2	B3	H	H1	H2	H3	S	
BSK2 20x20/2 .../O O	200	220	240	280	200	220	240	280	340	13.3
BSK2 25x20/2 .../O O	250	270	290	330	200	220	240	280	390	14.3
BSK2 25x25/2 .../O O	250	270	290	330	250	270	290	330	390	15.4
BSK2 30x20/2 .../O O	300	320	340	380	200	220	240	280	440	15.3
BSK2 30x25/2 .../O O	300	320	340	380	250	270	290	330	440	16.6
BSK2 30x30/2 .../O O	300	320	340	380	300	320	340	380	440	20.1
BSK2 40x25/2 .../O O	400	420	440	480	250	270	290	330	540	20.5
BSK2 40x30/2 .../O O	400	420	440	480	300	320	340	380	540	21
BSK2 40x40/2 .../O O	400	420	440	480	400	420	440	480	540	23.3
BSK2 50x30/2 .../O O	500	520	540	580	300	320	340	380	640	23.8
BSK2 50x40/2 .../O O	500	520	540	580	400	420	440	480	640	26
BSK2 50x50/2 .../O O	500	530	560	580	500	530	560	580	650	33
BSK2 60x40/2 .../O O	600	620	640	680	400	420	440	480	740	32.7
BSK2 60x50/2 .../O O	600	630	660	680	500	530	560	580	750	38.4
BSK2 60x60/2 .../O O	600	630	660	680	600	630	660	680	750	43
BSK2 80x50/2 .../O O	800	830	860	880	500	530	560	580	950	47
BSK2 80x60/2 .../O O	800	830	860	880	600	630	660	680	950	52
BSK2 80x80/2 .../O O	800	830	860	880	800	830	860	880	950	63
BSK2 100x60/2 .../O O	1000	1030	1060	1080	600	630	660	680	1150	63
BSK2 100x80/2 .../O O	1000	1030	1060	1080	800	830	860	880	1150	75
BSK2 100x100/2 .../O O	1000	1030	1060	1080	1000	1030	1060	1080	1150	87

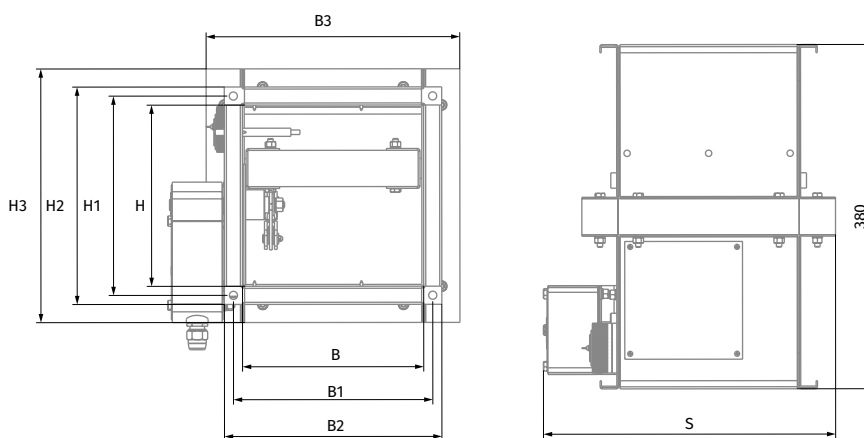

Note: The values given in the table for dampers with 230 V actuators are identical for those equipped with 24 V.

FLOW AREA OF THE DUCT FIRE-RESISTANT DAMPER WITH AN ELECTRIC ACTUATOR INSTALLED OUTSIDE THE DAMPER [M²]

B/H [mm]	200	250	300	400	500	600	800	1000
200	0.032							
250	0.04	0.053						
300	0.048	0.063	0.078					
400	0.064	0.084	0.104	0.144				
500	0.08	0.105	0.13	0.18	0.23			
600	0.096	0.126	0.156	0.216	0.276	0.336		
800	0.128	0.168	0.208	0.288	0.368	0.448	0.608	
1000	0.16	0.21	0.26	0.36	0.46	0.56	0.76	0.96

Dampers with dimensions not included in the table can be produced on request.
Limit damper size: 1000x1000 mm

Overall and connecting dimensions

BSK2...PKP...S/BSK2...PVP...S/BSK2...PSP...S DAMPERS WITH ELECTRIC ACTUATORS:

Duct cross-section	Dimensions [mm]							Weight [kg]
	B	B1	B2	B3	H	H1	H2	
BSK2 20x20/2 .../O O S	200	220	240	340	200	220	240	5.7
BSK2 25x20/2 .../O O S	250	270	290	390	200	220	240	6.2
BSK2 25x25/2 .../O O S	250	270	290	390	250	270	290	6.9
BSK2 30x20/2 .../O O S	300	320	340	440	200	220	240	6.8
BSK2 30x25/2 .../O O S	300	320	340	440	250	270	290	7.5
BSK2 30x30/2 .../O O S	300	320	340	440	300	320	340	9.2
BSK2 40x25/2 .../O O S	400	420	440	540	250	270	290	9
BSK2 40x30/2 .../O O S	400	420	440	540	300	320	340	10.8
BSK2 40x40/2 .../O O S	400	420	440	540	400	420	440	12.6
BSK2 50x30/2 .../O O S	500	520	540	640	300	320	340	12.3
BSK2 50x40/2 .../O O S	500	520	540	640	400	420	440	14.3
BSK2 50x50/2 .../O O S	500	530	560	650	500	530	560	23
BSK2 60x40/2 .../O O S	600	620	640	740	400	420	440	16.2
BSK2 60x50/2 .../O O S	600	630	660	750	500	530	560	25.6
BSK2 60x60/2 .../O O S	600	630	660	750	600	630	660	28.6
BSK2 80x50/2 .../O O S	800	830	860	950	500	530	560	31.3
BSK2 80x60/2 .../O O S	800	830	860	950	600	630	660	34.7
BSK2 80x80/2 .../O O S	800	830	860	950	800	830	860	42
BSK2 100x60/2 .../O O S	1000	1030	1060	1150	600	630	660	40.7
BSK2 100x80/2 .../O O S	1000	1030	1060	1150	800	830	860	50.2
BSK2 100x100/2 .../O O S	1000	1030	1060	1150	1000	1030	1060	58

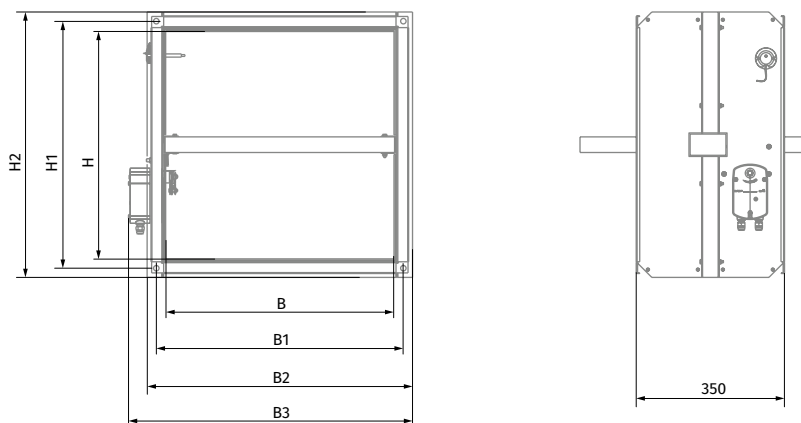

Note: The values given in the table for dampers with 230 V actuators are identical for those equipped with 24 V.

FLOW AREA OF THE DUCT FIRE-RESISTANT DAMPER WITH AN ELECTRIC ACTUATOR INSTALLED OUTSIDE THE DAMPER [m²]

B/H [mm]	200	250	300	400	500	600	800	1000
200	0.032							
250	0.04	0.053						
300	0.048	0.063	0.078					
400	0.064	0.084	0.104	0.144				
500	0.08	0.105	0.13	0.18	0.23			
600	0.096	0.126	0.156	0.216	0.276	0.336		
800	0.128	0.168	0.208	0.288	0.368	0.448	0.608	
1000	0.16	0.21	0.26	0.36	0.46	0.56	0.76	0.96

Dampers with dimensions not included in the table
 can be produced on request.
 Limit damper size: 1000x1000 mm

Technical data

BELIMO ELECTRIC ACTUATORS WITH A RETURN SPRING AND A THERMAL BREAKER

Parameters	Basic models		Models with increased torque		Models with the highest torque	
Rated voltage [V]	AC/DC 24	AC 230	AC/DC 24	AC 230	AC/DC 24	AC 230
Rated voltage range [V]	AC 19.2...28.8 DC 21.6...28.8	AC 198...264	AC 19.2...28.8 DC 21.6...28.8	AC 198...264	AC 19.2...28.8 DC 21.6...28.8	AC 198...264
Rated voltage frequency AC [Hz]	50/60		50/60		50/60	
Power consumption in rest position [W]	0.8	1.1	1.4	2.1	2	3
Power consumption in operation [W]	2.5	3.5	4	5	7	8.5
Maximum design capacity [VA]	4	6.5	6	10	10	11
Motor torque [Nm]	4		9		18	
Spring torque [Nm]	3		7		12	
Protection class	III	II	III	II	III	II
Ingress protection rating	IP54	IP54	IP54	IP54	IP54	IP54
Auxiliary switches	2 pcs., single-pole, reversible, 1 mA...3(0,5)A, AC 250 V				2 pcs., single-pole, reversible, 1 mA...6(3)A, AC 250 V	
Electric motor connection cable	1 m, 2 x 0.75 mm ² (halogen-free)					
Auxiliary switch connection cable	1 m, 6 x 0.75 mm ² (halogen-free)					
Running time spring	20 seconds at -10...+55 °C < 60 seconds at -30...-10 °C		20 seconds at -10...+55 °C < 60 seconds at -30...-10 °C		16 seconds at +20 °C	
Running time motor	< 60 s/90°		< 60 s/90°		< 120 s/90°	
Response temperature of thermal breaker sensors	Duct sensor 72 °C Outdoor sensor 72 °C					
Service life	Min. 60 000 emergency positions					
Technical maintenance	Not required					

ZERN ELECTRIC ACTUATORS WITH A RETURN SPRING AND A THERMAL BREAKER

Parameters	Basic models		Models with increased torque	
Rated voltage [V]	AC/DC 24	AC 100–240	AC/DC 24	AC 100–240
Rated voltage range [V]	AC/DC 19.2...28.8	AC 85...265	AC/DC 19.2...28.8	AC 85...265
Rated voltage frequency AC [Hz]	50/60		50/60	
Power consumption in rest position [W]	3		3	
Power consumption in operation [W]	5		5	
Motor torque [Nm]	5		8	
Spring torque [Nm]	5		8	
Protection class	III	II	III	II
Ingress protection rating	IP54	IP54	IP54	IP54
Auxiliary switches	2 pcs., single-pole, reversible, 1 mA...3(0,5)A, AC 220 V			
Electric motor connection cable	1 m, 2 x 0.5 mm ² (halogen-free)			
Auxiliary switch connection cable	1 m, 6 x 0.5 mm ² (halogen-free)			
Running time spring	<20 seconds < 60 seconds at -30...-10 °C		<25 seconds < 60 seconds at -30...-10 °C	
Running time motor	< 70 s/95°		< 100 s/95°	
Response temperature of thermal breaker sensors	Duct sensor 72 °C Outdoor sensor 72 °C			

SIEMENS ELECTRIC ACTUATORS WITH A RETURN SPRING AND A THERMAL BREAKER

Parameters	Basic models		Models with increased torque		Models with the highest torque	
Rated voltage [V]	AC 24/ DC 24...48	AC 230	AC 24/ DC 24...48	AC 230	AC 24/ DC 24...48	AC 230
Rated voltage range [V]	AC/DC ±20 %	AC ±15 %	AC/DC ±20 %	AC ±15 %	AC/DC ±20 %	AC ±15 %
Rated voltage frequency AC [Hz]	50/60		50/60		50/60	
Power consumption in rest position [W]	2	3.5	2	3.5	3	4
Power consumption in operation [W]	3.5	4.5	3.5	4.5	5	6
Maximum design capacity [VA]	5	7	5	7	7	8
Motor torque [Nm]	4		9		18	
Spring torque [Nm]	4		7		18	
Protection class	III	II	III	II	III	II
Ingress protection rating	IP54	IP54	IP54	IP54	IP54	IP54
Auxiliary switches	2 pcs., single-pole, reversible, 6(2)A, AC 24...250 V					
Electric motor connection cable	0.9 m, 2 x 0.75 mm ² (halogen-free)					
Auxiliary switch connection cable	0.9 m, 6 x 0.75 mm ² (halogen-free)					
Running time spring	15 seconds < 60 seconds at -30...-10 °C					
Running time motor	90 s/90°					
Response temperature of thermal breaker sensors	Duct sensor 72 °C Outdoor sensor 72 °C					
Service life	10 000 emergency positions					
Technical maintenance	Not required					

Electrical connection

BASIC MODELS BELIMO AND ZERN ELECTRIC ACTUATORS, BELIMO AND ZERN MODELS WITH INCREASED TORQUE

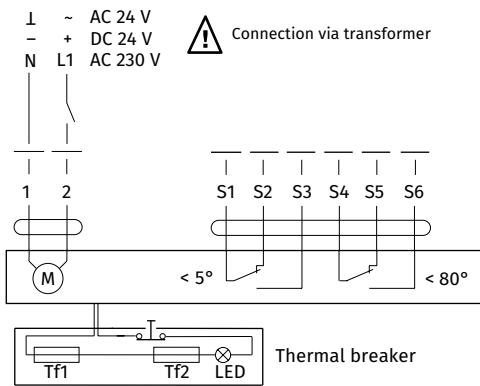

BELIMO ELECTRIC ACTUATORS WITH THE HIGHEST TORQUE, SIEMENS ELECTRIC ACTUATORS

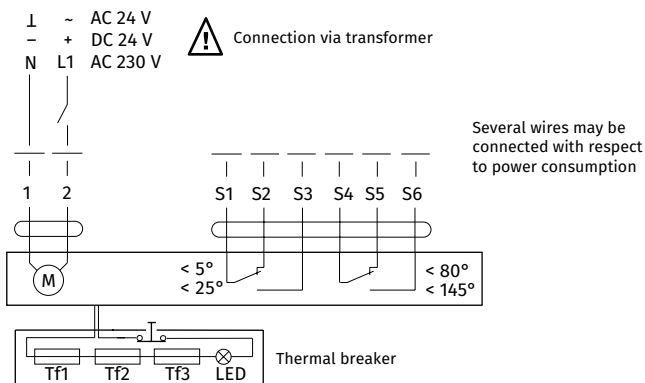

BSK

Fire-resisting dampers

Use

- A fire safety damper prevents the spread of smoke and fire via ventilation and air conditioning system ducts in the event of fire.
- Such units are installed in air ducts located in fire-separation walls and ceilings. The fire resistance rating according to EN 1366-2 is EIS 60 or EIS 120.



Normally open fire-resisting duct damper with a thermal fuse and a return spring

Normally open fire-resisting duct damper with an electric actuator, a return spring and a thermoelectric breaker

Design

- The **BSK** series dampers are made in the general-purpose industrial version with a minimized variety of hardware components using low-alloy galvanized steel. The flap is made of fire-resistant material (vermiculite) with thermoexpansive fireproof sealing.
- The duct design implies two connection ports for integration into a ventilation duct (duct system).

Control and modifications

- Depending on the design variant the **BSK** series dampers are equipped with:

MECHANICAL ACTUATING UNIT WITH A THERMAL FUSE AND A RETURN SPRING

- The fire safety damper remains open in the protective position. The damper is set to the operating position upon the thermal fuse breakdown resulting from a temperature increase. In the event of fire, the fusible element will melt upon the temperature reaching 72 °C and the spring will set the flap to the closed position.

ELECTRIC ACTUATOR WITH A BUILT-IN RETURN SPRING AND A THERMALLY SENSITIVE BREAKER

- Setting the damper to operating position (direct fire contact): remotely, via electric actuator. The damper can be set to the operating or protective position either remotely via a control panel or manually using the manual cocking handle which is always included in the standard delivery set of the electric actuator. In case of the remote control panel failure, the back-up thermal breaker interrupts the power supply to the electric actuator and the return spring sets the damper to the operating position. Emergency damper actuation: The damper flap is set to the protective position automatically (damper unaffected by fire). The electric actuator remains energized at all times. In case of an emergency actuation (direct fire contact): The electric actuator equipped with a return spring is de-energized and the damper flap is set to the operating position by means of the spring energy. In case of a power failure not related to fire and its subsequent restoration at the actuator with a return spring, the damper flap returns to a protective position.

Mounting

- During the fire safety damper installation make sure that the release mechanism and the inspection hole face an easily accessible side of the wall or ceiling. This will ensure convenient control of the thermally sensitive release mechanism and its internals.
- The damper can be embedded into brick or concrete walls with the appropriate fire resistance rating.
- Wooden spreader bars should be used to avoid casing deformation during the installation.

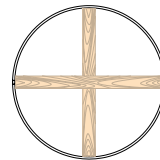

Use of wooden spreader bars during installation

- Upon completing the installation remove the wooden spreader bars.

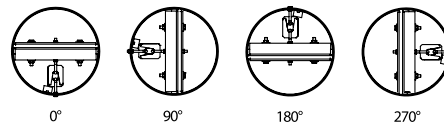

Recommended damper positions

- The damper may not be installed:
 - Into air ducts and on premises rated explosion and fire safety category A and B.
 - Into air ducts of local intakes for flammable and explosive mixtures.
 - Into systems which are do not undergo periodic cleaning pursuant to the established regulations for prevention of flammable deposit buildup.

Designation key

BSK 1 100 PVP24T

Series:
Fire-resisting damper

Fire resistance:
1: 1 hour
2: 2 hours

Rated damper diameter [mm]:
100; 125; 150; 160; 180; 200; 225; 250; 315; 355; 400

Actuator type:
1A: thermal fuse and return spring (manual actuation)
PKP24T: 24 V ZERN electric actuator with a return spring and a thermal breaker
PKP230T: 230 V ZERN electric actuator with a return spring and a thermal breaker
PVP24T: 24 V BELIMO electric actuator with a return spring and a thermal breaker
PVP230T: 230 V BELIMO electric actuator with a return spring and a thermal breaker
PSP24T: 24 V SIEMENS electric actuator with a return spring and a thermal breaker
PSP230T: 230 V SIEMENS actuator with a return spring and a thermal breaker

THE BSK...1A FIRE SAFETY DAMPER WITH A MECHANICAL ACTUATING UNIT, A THERMAL FUSE AND A RETURN SPRING

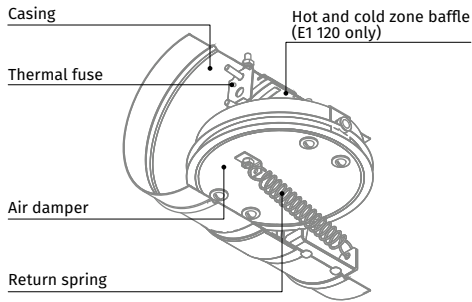

THE BSK...PKP/BSK...PVP/BSK...PSP FIRE SAFETY DAMPER WITH AN ELECTRIC ACTUATOR AND A THERMOELECTRIC BREAKER

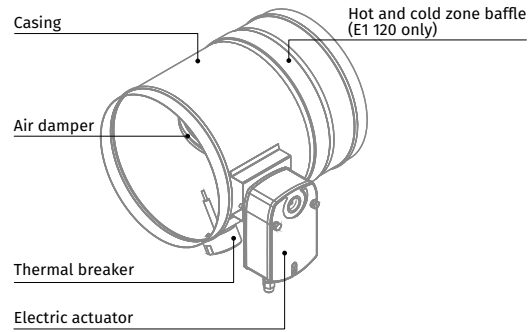

INSTALLATION RECOMMENDATIONS FOR BSK...1A DAMPERS WITH A MECHANICAL ACTUATING UNIT WITH A THERMAL FUSE AND A RETURN SPRING

IN VERTICAL BUILDING STRUCTURES

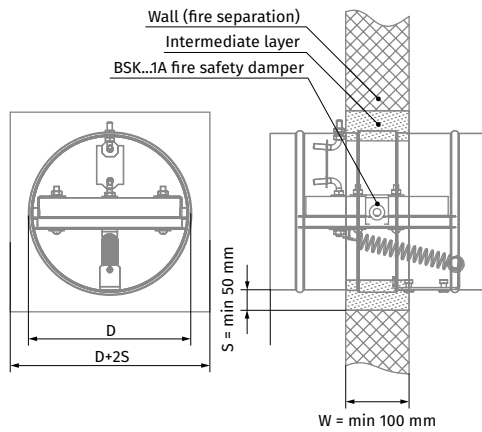

IN HORIZONTAL BUILDING STRUCTURES

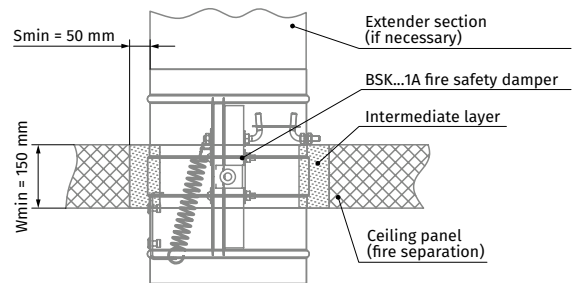

INSTALLATION RECOMMENDATIONS FOR BSK...PKP/BSK...PVP/BSK...PSP FIRE SAFETY DAMPERS WITH ELECTRIC ACTUATOR AND THERMOELECTRIC BREAKER

IN VERTICAL BUILDING STRUCTURES

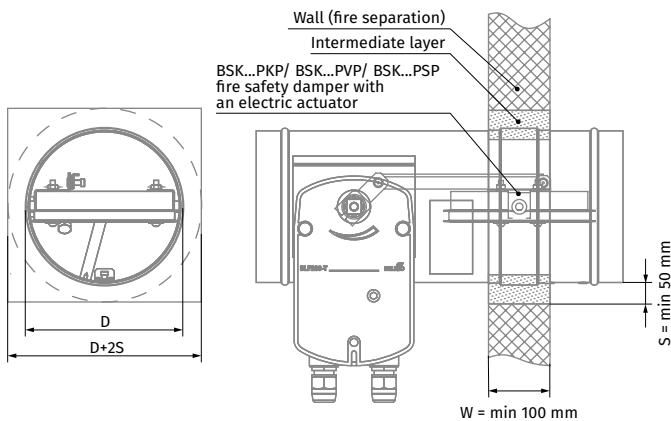

IN HORIZONTAL BUILDING STRUCTURES

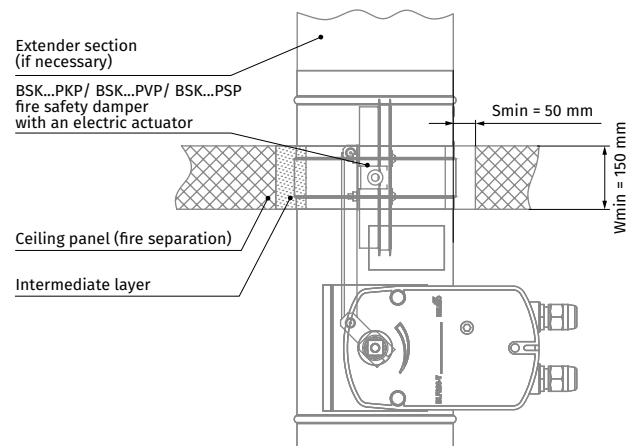

FIRE SAFETY DAMPER WITH A MECHANICAL ACTUATING UNIT, A THERMAL FUSE AND A RETURN SPRING

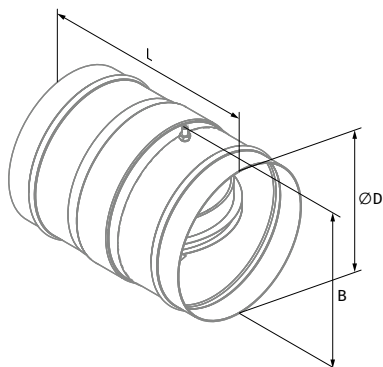

FIRE SAFETY DAMPER WITH AN ELECTRIC ACTUATOR AND A THERMALLY SENSITIVE BREAKER

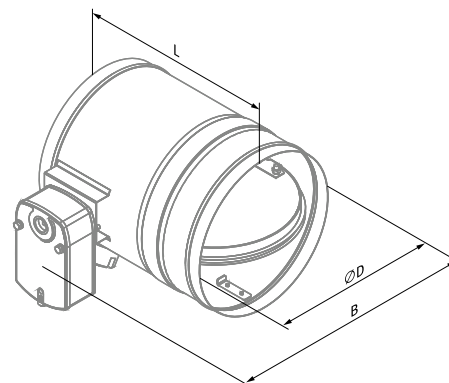

Overall and connecting dimensions

BSK DAMPERS WITH A MECHANICAL ACTUATOR

Modification	Dimensions [mm]			Weight [kg]
	Ø D	L	B	
BSK...100 1A	99	170	112	1
BSK...125 1A	124	170	137	1.2
BSK...150 1A	149	170	162	1.5
BSK...160 1A	159	170	172	1.6
BSK...180 1A	179	170	192	1.8
BSK...200 1A	199	170	212	2
BSK...225 1A	224	170	237	2.2
BSK...250 1A	249	190	262	2.5
BSK...315 1A	314	190	327	3.6
BSK...355 1A	354	190	367	4.4
BSK...400 1A	399	240	412	6

BSK DAMPERS WITH AN ELECTRIC ACTUATOR

Modification	Dimensions [mm]			Weight [kg]
	Ø D	L	B	
BSK...100 PKP(PVP, PSP)	99	300	195	2.9
BSK...125 PKP(PVP, PSP)	124	300	215	3.1
BSK...150 PKP(PVP, PSP)	149	300	245	3.4
BSK...160 PKP(PVP, PSP)	159	300	255	3.5
BSK...180 PKP(PVP, PSP)	179	300	275	3.8
BSK...200 PKP(PVP, PSP)	199	300	295	4
BSK...225 PKP(PVP, PSP)	224	300	325	4.4
BSK...250 PKP(PVP, PSP)	249	310	345	4.7
BSK...315 PKP(PVP, PSP)	314	310	415	6.5
BSK...355 PKP(PVP, PSP)	354	310	455	8.3
BSK...400 PKP(PVP, PSP)	399	310	505	9.9

Technical data

BELIMO ELECTRIC ACTUATORS WITH A RETURN SPRING AND A THERMAL BREAKER

Parameters	Basic models	
Rated voltage [V]	AC/DC 24	AC 230
Rated voltage range [V]	AC 19.2...28.8 DC 21.6...28.8	AC 198...264
Rated voltage frequency AC [Hz]	50/60	
Power consumption in rest position [W]	0.8	1.1
Power consumption in operation [W]	2.5	3.5
Maximum design capacity [VA]	4	6.5
Motor torque [Nm]	4	
Spring torque [Nm]	3	
Protection class	III	II
Ingress protection rating	IP54	IP54
Auxiliary switches	2 pcs., single-pole, reversible, 1 mA...3(0,5)A, AC 250 V	
Electric motor connection cable	1 m, 2 x 0.75 mm ² (halogen-free)	
Auxiliary switch connection cable	1 m, 6 x 0.75 mm ² (halogen-free)	
Running time spring	20 seconds at -10...+55 °C < 60 seconds at -30...-10 °C	
Running time motor	< 60 s/90°	
Response temperature of thermal breaker sensors	Duct sensor 72 °C Outdoor sensor 72 °C	
Service life	Min. 60 000 emergency positions	
Technical maintenance	Not required	

ZERN ELECTRIC ACTUATORS WITH A RETURN SPRING AND A THERMAL BREAKER

Parameters	Basic models	
Rated voltage [V]	AC/DC 24	AC 100-240
Rated voltage range [V]	AC/DC 19.2...28.8	AC 85...265
Rated voltage frequency AC [Hz]	50/60	
Power consumption in rest position [W]	3	
Power consumption in operation [W]	5	
Motor torque [Nm]	5	
Spring torque [Nm]	5	
Protection class	III	II
Ingress protection rating	IP54	IP54
Auxiliary switches	2 pcs., single-pole, reversible, 1 mA...3(0,5)A, AC 220 V	
Electric motor connection cable	1 m, 2 x 0.5 mm ² (halogen-free)	
Auxiliary switch connection cable	1 m, 6 x 0.5 mm ² (halogen-free)	
Running time spring	<20 seconds < 60 seconds at -30...-10 °C	
Running time motor	< 70 s/95°	
Response temperature of thermal breaker sensors	Duct sensor 72 °C Outdoor sensor 72 °C	

SIEMENS ELECTRIC ACTUATORS WITH A RETURN SPRING AND A THERMAL BREAKER

Parameters	Basic models	
Rated voltage [V]	AC 24/DC 24...48	AC 230
Rated voltage range [V]	AC/DC ±20 %	AC ±15 %
Rated voltage frequency AC [Hz]	50/60	
Power consumption in rest position [W]	2	3.5
Power consumption in operation [W]	3.5	4.5
Maximum design capacity [VA]	5	7
Motor torque [Nm]	4	
Spring torque [Nm]	4	
Protection class	III	II
Ingress protection rating	IP54	IP54
Auxiliary switches	2 pcs., single-pole, reversible, 6(2)A, AC 24...250 V	
Electric motor connection cable	0.9 m, 2 x 0.75 mm ² (halogen-free)	
Auxiliary switch connection cable	0.9 m, 6 x 0.75 mm ² (halogen-free)	
Running time spring	15 seconds < 60 seconds at -30...-10 °C	
Running time motor	90 s/90°	
Response temperature of thermal breaker sensors	Duct sensor 72 °C Outdoor sensor 72 °C	
Service life	10 000 emergency positions	
Technical maintenance	Not required	

D-RSK

Smoke exhaust grille for fire safety dampers



Use

- The **RSKE/RSKM** smoke exhaust dampers and the **BSK-1, BSK-2** wall-mounted fire-resisting dampers (1 flange) can be additionally equipped with a smoke exhaust grille.
- The smoke exhaust grille is used to entirely block the external view of the damper internals in the absence of strict requirements to the unit appearance.
- The smoke exhaust grille also doubles as unauthorized access protection for the damper and its actuator. The grille has a single horizontal row of non-adjustable air flow guides fixed at 45°.

Design

- The grille can be made of galvanized steel (Zn), carbon steel with a special coating (M), stainless steel (N) or aluminium (A).

Mounting

- The grille is attached directly to the damper flange by means of self-tapping screws with the louvre shutters facing outwards.

Designation key

Series:
Smoke exhaust grille

Material:
Zn: galvanized steel
M: carbon steel with a special coating
N: stainless steel
A: aluminium

Damper type:
RSKM, RSKE

Working section of the damper: BxH (B – width [mm]; H – height [mm])
Damper flow area width [mm]: 300; 350; 400; 450; 500; 550; 600; 650; 700; 750; 800; 850; 900; 950; 1000
Damper flow area height [mm]: 300; 350; 400; 450; 500; 550; 600; 650; 700; 750; 800; 850; 900; 950; 1000

D-RSK X - X - X

Overall dimensions [mm]

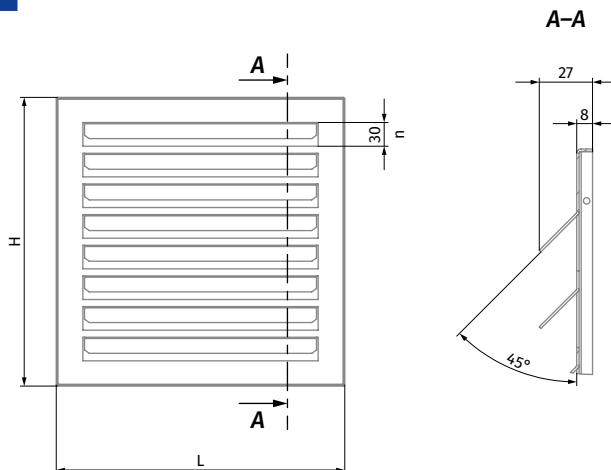
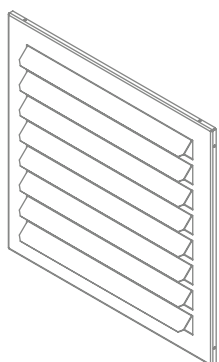

- When ordering smoke exhaust grilles for BSK-1 and BSK-2 dampers, it is necessary to order a grille with the name D-RSK... RSKM...

Model	H	L	n [items]	Cross-sectional area [m ²]	Weight of the galvanized steel grille [kg]
D-RSK 300x300 (for RSKE)	367	367	8	0.059	1.29
D-RSK 350x300 (for RSKE)	367	417	8	0.069	1.46
D-RSK 400x300 (for RSKE)	367	467	8	0.080	1.63
D-RSK 450x300 (for RSKE)	367	517	8	0.090	1.80
D-RSK 500x300 (for RSKE)	367	567	8	0.101	1.97
D-RSK 550x300 (RSKM/RSKE)	367	617	8	0.111	2.14
D-RSK 600x300 (RSKM/RSKE)	367	667	8	0.122	2.32
D-RSK 650x300 (RSKM/RSKE)	367	717	8	0.132	2.49
D-RSK 700x300 (RSKM/RSKE)	367	767	8	0.143	2.66
D-RSK 750x300 (RSKM/RSKE)	367	817	8	0.153	2.83
D-RSK 800x300 (RSKM/RSKE)	367	867	8	0.164	3.00
D-RSK 850x300 (RSKM/RSKE)	367	917	8	0.174	3.17
D-RSK 900x300 (RSKM/RSKE)	367	967	8	0.185	3.34
D-RSK 950x300 (RSKM/RSKE)	367	1017	8	0.195	3.51
D-RSK 1000x300 (RSKM/RSKE)	367	1067	8	0.206	3.68
D-RSK 350x350 (for RSKE)	417	417	9	0.079	1.66
D-RSK 400x350 (for RSKE)	417	467	9	0.091	1.85
D-RSK 450x350 (for RSKE)	417	517	9	0.103	2.04
D-RSK 500x350 (for RSKE)	417	567	9	0.115	2.24
D-RSK 550x350 (RSKM/RSKE)	417	617	9	0.127	2.43
D-RSK 600x350 (RSKM/RSKE)	417	667	9	0.139	2.62
D-RSK 650x350 (RSKM/RSKE)	417	717	9	0.151	2.81
D-RSK 700x350 (RSKM/RSKE)	417	767	9	0.163	3.01
D-RSK 750x350 (RSKM/RSKE)	417	817	9	0.175	3.20
D-RSK 800x350 (RSKM/RSKE)	417	867	9	0.187	3.39
D-RSK 850x350 (RSKM/RSKE)	417	917	9	0.199	3.59
D-RSK 900x350 (RSKM/RSKE)	417	967	9	0.211	3.78
D-RSK 950x350 (RSKM/RSKE)	417	1017	9	0.223	3.97
D-RSK 1000x350 (RSKM/RSKE)	417	1067	9	0.235	4.17
D-RSK 400x400 (for RSKE)	467	467	10	0.114	2.07
D-RSK 450x400 (for RSKE)	467	517	10	0.129	2.28
D-RSK 500x400 (for RSKE)	467	567	10	0.144	2.50
D-RSK 550x400 (RSKM/RSKE)	467	617	10	0.159	2.71
D-RSK 600x400 (RSKM/RSKE)	467	667	10	0.174	2.93
D-RSK 650x400 (RSKM/RSKE)	467	717	10	0.189	3.14
D-RSK 700x400 (RSKM/RSKE)	467	767	10	0.204	3.36
D-RSK 750x400 (RSKM/RSKE)	467	817	10	0.219	3.57
D-RSK 800x400 (RSKM/RSKE)	467	867	10	0.234	3.79
D-RSK 850x400 (RSKM/RSKE)	467	917	10	0.249	4.01
D-RSK 900x400 (RSKM/RSKE)	467	967	10	0.264	4.22
D-RSK 950x400 (RSKM/RSKE)	467	1017	10	0.279	4.44
D-RSK 1000x400 (RSKM/RSKE)	467	1067	10	0.294	4.65
D-RSK 450x450 (for RSKE)	517	517	12	0.142	2.51
D-RSK 500x450 (for RSKE)	517	567	12	0.158	2.75

Model	H	L	n [items]	Cross-sectional area [m ²]	Weight of the galvanized steel grille [kg]
D-RSK 550x450 (RSKM/RSKE)	517	617	12	0.175	2.98
D-RSK 600x450 (RSKM/RSKE)	517	667	12	0.191	3.22
D-RSK 650x450 (RSKM/RSKE)	517	717	12	0.208	3.46
D-RSK 700x450 (RSKM/RSKE)	517	767	12	0.224	3.69
D-RSK 750x450 (RSKM/RSKE)	517	817	12	0.241	3.93
D-RSK 800x450 (RSKM/RSKE)	517	867	12	0.257	4.17
D-RSK 850x450 (RSKM/RSKE)	517	917	12	0.274	4.41
D-RSK 900x450 (RSKM/RSKE)	517	967	12	0.290	4.64
D-RSK 950x450 (RSKM/RSKE)	517	1017	12	0.307	4.88
D-RSK 1000x450 (RSKM/RSKE)	517	1067	12	0.323	5.12
D-RSK 500x500 (for RSKE)	567	567	13	0.173	3.01
D-RSK 550x500 (RSKM/RSKE)	567	617	13	0.191	3.27
D-RSK 600x500 (RSKM/RSKE)	567	667	13	0.209	3.53
D-RSK 650x500 (RSKM/RSKE)	567	717	13	0.227	3.79
D-RSK 700x500 (RSKM/RSKE)	567	767	13	0.245	4.05
D-RSK 750x500 (RSKM/RSKE)	567	817	13	0.263	4.31
D-RSK 800x500 (RSKM/RSKE)	567	867	13	0.281	4.57
D-RSK 850x500 (RSKM/RSKE)	567	917	13	0.299	4.82
D-RSK 900x500 (RSKM/RSKE)	567	967	13	0.317	5.08
D-RSK 950x500 (RSKM/RSKE)	567	1017	13	0.335	5.34
D-RSK 1000x500 (RSKM/RSKE)	567	1067	13	0.353	5.60
D-RSK 550x550 (RSKM/RSKE)	617	617	14	0.207	3.55
D-RSK 600x550 (RSKM/RSKE)	617	667	14	0.226	3.83
D-RSK 650x550 (RSKM/RSKE)	617	717	14	0.246	4.12
D-RSK 700x550 (RSKM/RSKE)	617	767	14	0.265	4.40
D-RSK 750x550 (RSKM/RSKE)	617	817	14	0.285	4.68
D-RSK 800x550 (RSKM/RSKE)	617	867	14	0.304	4.96
D-RSK 850x550 (RSKM/RSKE)	617	917	14	0.324	5.24
D-RSK 900x550 (RSKM/RSKE)	617	967	14	0.343	5.53
D-RSK 950x550 (RSKM/RSKE)	617	1017	14	0.363	5.81
D-RSK 1000x550 (RSKM/RSKE)	617	1067	14	0.382	6.09
D-RSK 600x600 (RSKM/RSKE)	667	667	15	0.244	4.14
D-RSK 650x600 (RSKM/RSKE)	667	717	15	0.265	4.44
D-RSK 700x600 (RSKM/RSKE)	667	767	15	0.286	4.75
D-RSK 750x600 (RSKM/RSKE)	667	817	15	0.307	5.05
D-RSK 800x600 (RSKM/RSKE)	667	867	15	0.328	5.36
D-RSK 850x600 (RSKM/RSKE)	667	917	15	0.349	5.66
D-RSK 900x600 (RSKM/RSKE)	667	967	15	0.370	5.97
D-RSK 950x600 (RSKM/RSKE)	667	1017	15	0.391	6.27
D-RSK 1000x600 (RSKM/RSKE)	667	1067	15	0.412	6.58
D-RSK 650x650 (RSKM/RSKE)	717	717	16	0.284	4.77
D-RSK 700x650 (RSKM/RSKE)	717	767	16	0.306	5.10
D-RSK 750x650 (RSKM/RSKE)	717	817	16	0.329	5.43
D-RSK 800x650 (RSKM/RSKE)	717	867	16	0.351	5.75
D-RSK 850x650 (RSKM/RSKE)	717	917	16	0.374	6.08
D-RSK 900x650 (RSKM/RSKE)	717	967	16	0.396	6.41
D-RSK 950x650 (RSKM/RSKE)	717	1017	16	0.419	6.74
D-RSK 1000x650 (RSKM/RSKE)	717	1067	16	0.441	7.06
D-RSK 700x700 (RSKM/RSKE)	767	767	18	0.347	5.44
D-RSK 750x700 (RSKM/RSKE)	767	817	18	0.372	5.78
D-RSK 800x700 (RSKM/RSKE)	767	867	18	0.398	6.13
D-RSK 850x700 (RSKM/RSKE)	767	917	18	0.423	6.48
D-RSK 900x700 (RSKM/RSKE)	767	967	18	0.449	6.83
D-RSK 950x700 (RSKM/RSKE)	767	1017	18	0.474	7.18
D-RSK 1000x700 (RSKM/RSKE)	767	1067	18	0.500	7.53
D-RSK 750x750 (RSKM/RSKE)	817	817	19	0.394	6.16
D-RSK 800x750 (RSKM/RSKE)	817	867	19	0.421	6.53
D-RSK 850x750 (RSKM/RSKE)	817	917	19	0.448	6.90
D-RSK 900x750 (RSKM/RSKE)	817	967	19	0.475	7.27
D-RSK 950x750 (RSKM/RSKE)	817	1017	19	0.502	7.64
D-RSK 1000x750 (RSKM/RSKE)	817	1067	19	0.529	8.01

Model	H	L	n [items]	Cross-sectional area [m ²]	Weight of the galvanized steel grille [kg]
D-RSK 800x800 (RSKM/RSKE)	867	867	20	0.445	6.93
D-RSK 850x800 (RSKM/RSKE)	867	917	20	0.473	7.32
D-RSK 900x800 (RSKM/RSKE)	867	967	20	0.502	7.71
D-RSK 950x800 (RSKM/RSKE)	867	1017	20	0.530	8.11
D-RSK 1000x800 (RSKM/RSKE)	867	1067	20	0.559	8.50
D-RSK 850x850 (RSKM/RSKE)	917	917	21	0.498	7.74
D-RSK 900x850 (RSKM/RSKE)	917	967	21	0.528	8.16
D-RSK 950x850 (RSKM/RSKE)	917	1017	21	0.558	8.57
D-RSK 1000x850 (RSKM/RSKE)	917	1067	21	0.588	8.99
D-RSK 900x900 (RSKM/RSKE)	967	967	22	0.554	8.60
D-RSK 950x900 (RSKM/RSKE)	967	1017	22	0.586	9.04
D-RSK 1000x900 (RSKM/RSKE)	967	1067	22	0.617	9.47
D-RSK 950x950 (RSKM/RSKE)	1017	1017	23	0.614	9.50
D-RSK 1000x950 (RSKM/RSKE)	1017	1067	23	0.647	9.96
D-RSK 1000x1000 (RSKM/RSKE)	1067	1067	24	0.676	10.45
D-RSK 300x300 (for RSKM)	347	347	8	0.059	1.15
D-RSK 350x300 (for RSKM)	347	397	8	0.069	1.31
D-RSK 400x300 (for RSKM)	347	447	8	0.080	1.48
D-RSK 450x300 (for RSKM)	347	497	8	0.090	1.64
D-RSK 500x300 (for RSKM)	347	547	8	0.101	1.80
D-RSK 350x350 (for RSKM)	397	397	9	0.079	1.50
D-RSK 400x350 (for RSKM)	397	447	9	0.091	1.68
D-RSK 450x350 (for RSKM)	397	497	9	0.103	1.87
D-RSK 500x350 (for RSKM)	397	547	9	0.115	2.05
D-RSK 400x400 (for RSKM)	447	447	10	0.114	1.89
D-RSK 450x400 (for RSKM)	447	497	10	0.129	2.09
D-RSK 500x400 (for RSKM)	447	547	10	0.144	2.30
D-RSK 450x450 (for RSKM)	497	497	11	0.142	2.32
D-RSK 500x450 (for RSKM)	497	547	11	0.158	2.55
D-RSK 500x500 (for RSKM)	547	547	12	0.173	2.79

The BSK-1, BSK-2 fire-resisting duct dampers (2 flanges) for completing with an D-RSK grille can be ordered separately.

S-RSK

Protective grille for fire safety dampers

Use

- The **RSKE/RSKM** smoke exhaust dampers and the **BSK-1, BSK-2** wall-mounted fire-resisting dampers (1 flange) can be additionally equipped with a protective grille **S-RSK**.
- The protective grille serves for protection against unauthorized access to the damper and its actuating mechanism.



Design

- The grille is only made from galvanized steel.

Mounting

- The grille is attached directly to the damper flange by means of self-tapping screws.

Designation key

S-RSK X

Series:
Protective grille

Working section of the damper: BxH (B – width [mm]; H – height [mm])
Damper flow area width [mm]: 300; 350; 400; 450; 500; 550; 600; 650; 700; 750; 800; 850; 900; 950; 1000
Damper flow area height [mm]: 300; 350; 400; 450; 500; 550; 600; 650; 700; 750; 800; 850; 900; 950; 1000

Overall dimensions [mm]

Model	H	L	Cross-sectional area [m ²]	Weight [kg]
S-RSK 300x300	340	340	0.072	0.75
S-RSK 350x300	340	390	0.090	0.86
S-RSK 350x350	390	390	0.103	0.91
S-RSK 400x300	340	440	0.103	0.91
S-RSK 400x350	390	440	0.120	0.94
S-RSK 400x400	440	440	0.141	0.99
S-RSK 450x300	340	490	0.120	0.94
S-RSK 450x350	390	490	0.141	0.99
S-RSK 450x400	440	490	0.159	1.02
S-RSK 450x450	490	490	0.178	1.12
S-RSK 500x300	340	540	0.141	0.99
S-RSK 500x350	390	540	0.159	1.02
S-RSK 500x400	440	540	0.178	1.12
S-RSK 500x450	490	540	0.190	1.20
S-RSK 500x500	540	540	0.210	1.22
S-RSK 550x300	360	610	0.159	1.02
S-RSK 550x350	410	610	0.178	1.12
S-RSK 550x400	460	610	0.190	1.20
S-RSK 550x450	510	610	0.210	1.22

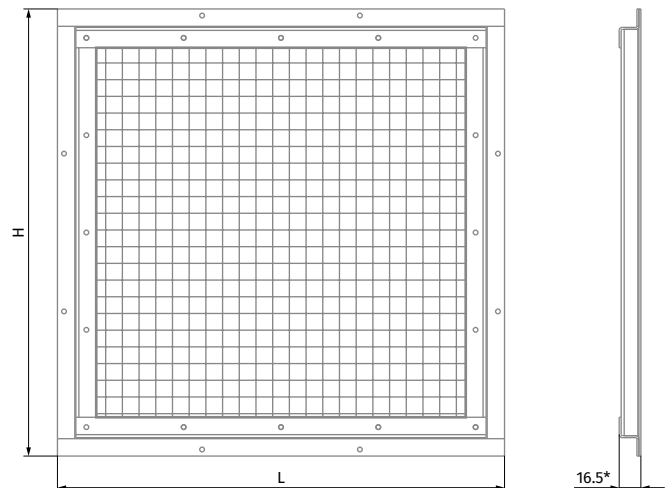

Model	H	L	Cross-sectional area [m ²]	Weight [kg]
S-RSK 550x500	560	610	0.269	1.30
S-RSK 550x550	610	610	0.293	1.37
S-RSK 600x300	360	660	0.178	1.12
S-RSK 600x350	410	660	0.190	1.20
S-RSK 600x400	460	660	0.210	1.22
S-RSK 600x450	510	660	0.269	1.30
S-RSK 600x500	560	660	0.293	1.37
S-RSK 600x550	610	660	0.305	1.42
S-RSK 600x600	660	660	0.321	1.45
S-RSK 650x300	360	710	0.190	1.30
S-RSK 650x350	410	710	0.210	1.22
S-RSK 650x400	460	710	0.269	1.30
S-RSK 650x450	510	710	0.293	1.37
S-RSK 650x500	560	710	0.305	1.42
S-RSK 650x550	610	710	0.321	1.45
S-RSK 650x600	660	710	0.340	1.48
S-RSK 650x650	710	710	0.392	1.51
S-RSK 700x300	360	760	0.210	1.22
S-RSK 700x350	410	760	0.269	1.30
S-RSK 700x400	460	760	0.293	1.37
S-RSK 700x450	510	760	0.305	1.42
S-RSK 700x500	560	760	0.321	1.45
S-RSK 700x550	610	760	0.340	1.48
S-RSK 700x600	660	760	0.392	1.51
S-RSK 700x650	710	760	0.411	1.56
S-RSK 700x700	760	760	0.446	1.59
S-RSK 750x300	360	810	0.269	1.30
S-RSK 750x350	410	810	0.293	1.37
S-RSK 750x400	460	810	0.305	1.42
S-RSK 750x450	510	810	0.321	1.45
S-RSK 750x500	560	810	0.340	1.48
S-RSK 750x550	610	810	0.392	1.51
S-RSK 750x600	660	810	0.411	1.56
S-RSK 750x650	710	810	0.446	1.59
S-RSK 750x700	760	810	0.495	1.65
S-RSK 750x750	810	810	0.507	1.70
S-RSK 800x300	360	860	0.293	1.37
S-RSK 800x350	410	860	0.305	1.42
S-RSK 800x400	460	860	0.321	1.45
S-RSK 800x450	510	860	0.340	1.48
S-RSK 800x500	560	860	0.392	1.51
S-RSK 800x550	610	860	0.411	1.56
S-RSK 800x600	660	860	0.446	1.59
S-RSK 800x650	710	860	0.495	1.65
S-RSK 800x700	760	860	0.507	1.70
S-RSK 800x750	810	860	0.582	1.74
S-RSK 800x800	860	860	0.614	1.78
S-RSK 850x300	360	910	0.305	1.46
S-RSK 850x350	410	910	0.321	1.45
S-RSK 850x400	460	910	0.340	1.48
S-RSK 850x450	510	910	0.392	1.51

Model	H	L	Cross-sectional area [m ²]	Weight [kg]
S-RSK 850x500	560	910	0.411	1.56
S-RSK 850x550	610	910	0.446	1.59
S-RSK 850x600	660	910	0.495	1.65
S-RSK 850x650	710	910	0.507	1.70
S-RSK 850x700	760	910	0.582	1.74
S-RSK 850x750	810	910	0.614	1.78
S-RSK 850x800	860	910	0.639	1.84
S-RSK 850x850	910	910	0.694	1.90
S-RSK 900x300	360	960	0.321	1.45
S-RSK 900x350	410	960	0.340	1.48
S-RSK 900x400	460	960	0.392	1.51
S-RSK 900x450	510	960	0.411	1.56
S-RSK 900x500	560	960	0.446	1.59
S-RSK 900x550	610	960	0.495	1.65
S-RSK 900x600	660	960	0.507	1.70
S-RSK 900x650	710	960	0.582	1.74
S-RSK 900x700	760	960	0.614	1.78
S-RSK 900x750	810	960	0.639	1.84
S-RSK 900x800	860	960	0.694	1.90
S-RSK 900x850	910	960	0.715	1.93
S-RSK 900x900	960	960	0.769	1.98
S-RSK 950x300	360	1010	0.340	1.48
S-RSK 950x350	410	1010	0.392	1.51
S-RSK 950x400	460	1010	0.411	1.56
S-RSK 950x450	510	1010	0.446	1.59
S-RSK 950x500	560	1010	0.495	1.65
S-RSK 950x550	610	1010	0.507	1.70
S-RSK 950x600	660	1010	0.582	1.74
S-RSK 950x650	710	1010	0.614	1.78
S-RSK 950x700	760	1010	0.639	1.84
S-RSK 950x750	810	1010	0.694	1.90
S-RSK 950x800	860	1010	0.715	1.93
S-RSK 950x850	910	1010	0.769	1.98
S-RSK 950x900	960	1010	0.811	2.05
S-RSK 950x950	1010	1010	0.874	2.10
S-RSK 1000x300	360	1060	0.392	1.51
S-RSK 1000x350	410	1060	0.411	1.56
S-RSK 1000x400	460	1060	0.446	1.59
S-RSK 1000x450	510	1060	0.495	1.65
S-RSK 1000x500	560	1060	0.507	1.70
S-RSK 1000x550	610	1060	0.582	1.74
S-RSK 1000x600	660	1060	0.614	1.78
S-RSK 1000x650	710	1060	0.639	1.84
S-RSK 1000x700	760	1060	0.694	1.90
S-RSK 1000x750	810	1060	0.715	1.93
S-RSK 1000x800	860	1060	0.769	1.98
S-RSK 1000x850	910	1060	0.811	2.05
S-RSK 1000x900	960	1060	0.874	2.10
S-RSK 1000x950	1010	1060	0.913	2.17
S-RSK 1000x1000	1060	1060	0.945	2.21

The BSK-1, BSK-2 fire-resisting duct dampers (2 flanges) for completing with an S-RSK grille can be ordered separately.

MR RSKE/RSKM

Mounting frame for fire safety dampers

Use

- The **RSKE/RSKM** smoke exhaust dampers can be additionally equipped with a mounting frame.
- The mounting frame eases the installation of the damper in the wall opening, creating additional rigidity and preventing deformation of the damper during installation.

Designation key

MR RSKE/RSKM X

Series:
Mounting frame

Working section of the damper: BxH (B – width [mm]; H – height [mm])
 Damper flow area width [mm]: 550; 600; 650; 700; 750; 800; 850; 900; 950; 1000
 Damper flow area height [mm]: 300; 350; 400; 450; 500; 550; 600; 650; 700; 750; 800; 850; 900; 950; 1000

Overall dimensions [mm]

Model	H	H1	H2	H3	L	L1	L2	L3	Weight [kg]
MR RSKE/RSKM 550x300	317	345	370	330.6	567	580	620	580.6	2.97
MR RSKE/RSKM 600x300	317	345	370	330.6	617	630	670	630.6	3.13
MR RSKE/RSKM 650x300	317	345	370	330.6	667	680	720	680.6	3.29
MR RSKE/RSKM 700x300	317	345	370	330.6	717	730	770	730.6	3.45
MR RSKE/RSKM 750x300	317	345	370	330.6	767	780	820	780.6	3.61
MR RSKE/RSKM 800x300	317	345	370	330.6	817	830	870	830.6	3.77
MR RSKE/RSKM 850x300	317	345	370	330.6	867	880	920	880.6	3.93
MR RSKE/RSKM 900x300	317	345	370	330.6	917	930	970	930.6	4.09
MR RSKE/RSKM 950x300	317	345	370	330.6	967	980	1020	980.6	4.25
MR RSKE/RSKM 1000x300	317	345	370	330.6	1017	1030	1070	1030.6	4.41
MR RSKE/RSKM 550x350	367	395	420	380.6	567	580	620	580.6	3.13
MR RSKE/RSKM 600x350	367	395	420	380.6	617	630	670	630.6	3.29
MR RSKE/RSKM 650x350	367	395	420	380.6	667	680	720	680.6	3.45
MR RSKE/RSKM 700x350	367	395	420	380.6	717	730	770	730.6	3.61
MR RSKE/RSKM 750x350	367	395	420	380.6	767	780	820	780.6	3.77
MR RSKE/RSKM 800x350	367	395	420	380.6	817	830	870	830.6	3.93
MR RSKE/RSKM 850x350	367	395	420	380.6	867	880	920	880.6	4.09
MR RSKE/RSKM 900x350	367	395	420	380.6	917	930	970	930.6	4.25
MR RSKE/RSKM 950x350	367	395	420	380.6	967	980	1020	980.6	4.41
MR RSKE/RSKM 1000x350	367	395	420	380.6	1017	1030	1070	1030.6	4.57
MR RSKE/RSKM 550x400	417	445	470	430.6	567	580	620	580.6	3.29
MR RSKE/RSKM 600x400	417	445	470	430.6	617	630	670	630.6	3.45
MR RSKE/RSKM 650x400	417	445	470	430.6	667	680	720	680.6	3.61
MR RSKE/RSKM 700x400	417	445	470	430.6	717	730	770	730.6	3.77
MR RSKE/RSKM 750x400	417	445	470	430.6	767	780	820	780.6	3.93
MR RSKE/RSKM 800x400	417	445	470	430.6	817	830	870	830.6	4.09
MR RSKE/RSKM 850x400	417	445	470	430.6	867	880	920	880.6	4.25
MR RSKE/RSKM 900x400	417	445	470	430.6	917	930	970	930.6	4.41
MR RSKE/RSKM 950x400	417	445	470	430.6	967	980	1020	980.6	4.57
MR RSKE/RSKM 1000x400	417	445	470	430.6	1017	1030	1070	1030.6	4.73
MR RSKE/RSKM 550x450	467	495	520	480.6	567	580	620	580.6	3.45
MR RSKE/RSKM 600x450	467	495	520	480.6	617	630	670	630.6	3.61

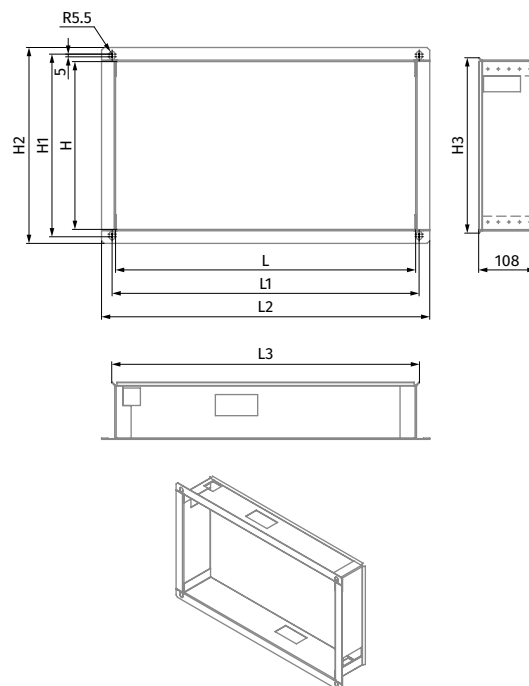

Model	H	H1	H2	H3	L	L1	L2	L3	Weight [kg]
MR RSKE/RSKM 650x450	467	495	520	480.6	667	680	720	680.6	3.77
MR RSKE/RSKM 700x450	467	495	520	480.6	717	730	770	730.6	3.93
MR RSKE/RSKM 750x450	467	495	520	480.6	767	780	820	780.6	4.09
MR RSKE/RSKM 800x450	467	495	520	480.6	817	830	870	830.6	4.25
MR RSKE/RSKM 850x450	467	495	520	480.6	867	880	920	880.6	4.41
MR RSKE/RSKM 900x450	467	495	520	480.6	917	930	970	930.6	4.57
MR RSKE/RSKM 950x450	467	495	520	480.6	967	980	1020	980.6	4.73
MR RSKE/RSKM 1000x450	467	495	520	480.6	1017	1030	1070	1030.6	4.89
MR RSKE/RSKM 550x500	517	545	570	530.6	567	580	620	580.6	3.61
MR RSKE/RSKM 600x500	517	545	570	530.6	617	630	670	630.6	3.77
MR RSKE/RSKM 650x500	517	545	570	530.6	667	680	720	680.6	3.93
MR RSKE/RSKM 700x500	517	545	570	530.6	717	730	770	730.6	4.09
MR RSKE/RSKM 750x500	517	545	570	530.6	767	780	820	780.6	4.25
MR RSKE/RSKM 800x500	517	545	570	530.6	817	830	870	830.6	4.41
MR RSKE/RSKM 850x500	517	545	570	530.6	867	880	920	880.6	4.57
MR RSKE/RSKM 900x500	517	545	570	530.6	917	930	970	930.6	4.73
MR RSKE/RSKM 950x500	517	545	570	530.6	967	980	1020	980.6	4.89
MR RSKE/RSKM 1000x500	517	545	570	530.6	1017	1030	1070	1030.6	5.05
MR RSKE/RSKM 550x550	567	595	620	580.6	567	580	620	580.6	3.77
MR RSKE/RSKM 600x550	567	595	620	580.6	617	630	670	630.6	3.93
MR RSKE/RSKM 650x550	567	595	620	580.6	667	680	720	680.6	4.09
MR RSKE/RSKM 700x550	567	595	620	580.6	717	730	770	730.6	4.25
MR RSKE/RSKM 750x550	567	595	620	580.6	767	780	820	780.6	4.41
MR RSKE/RSKM 800x550	567	595	620	580.6	817	830	870	830.6	4.57
MR RSKE/RSKM 850x550	567	595	620	580.6	867	880	920	880.6	4.73
MR RSKE/RSKM 900x550	567	595	620	580.6	917	930	970	930.6	4.89
MR RSKE/RSKM 950x550	567	595	620	580.6	967	980	1020	980.6	5.05
MR RSKE/RSKM 1000x550	567	595	620	580.6	1017	1030	1070	1030.6	5.21
MR RSKE/RSKM 600x600	617	645	670	630.6	617	630	670	630.6	4.09
MR RSKE/RSKM 650x600	617	645	670	630.6	667	680	720	680.6	4.25
MR RSKE/RSKM 700x600	617	645	670	630.6	717	730	770	730.6	4.41
MR RSKE/RSKM 750x600	617	645	670	630.6	767	780	820	780.6	4.57
MR RSKE/RSKM 800x600	617	645	670	630.6	817	830	870	830.6	4.73
MR RSKE/RSKM 850x600	617	645	670	630.6	867	880	920	880.6	4.89
MR RSKE/RSKM 900x600	617	645	670	630.6	917	930	970	930.6	5.05
MR RSKE/RSKM 950x600	617	645	670	630.6	967	980	1020	980.6	5.21
MR RSKE/RSKM 1000x600	617	645	670	630.6	1017	1030	1070	1030.6	5.37
MR RSKE/RSKM 650x650	667	695	720	680.6	667	680	720	680.6	4.41
MR RSKE/RSKM 700x650	667	695	720	680.6	717	730	770	730.6	4.57
MR RSKE/RSKM 750x650	667	695	720	680.6	767	780	820	780.6	4.73
MR RSKE/RSKM 800x650	667	695	720	680.6	817	830	870	830.6	4.89
MR RSKE/RSKM 850x650	667	695	720	680.6	867	880	920	880.6	5.05
MR RSKE/RSKM 900x650	667	695	720	680.6	917	930	970	930.6	5.21
MR RSKE/RSKM 950x650	667	695	720	680.6	967	980	1020	980.6	5.37
MR RSKE/RSKM 1000x650	667	695	720	680.6	1017	1030	1070	1030.6	5.53
MR RSKE/RSKM 700x700	717	745	770	730.6	717	730	770	730.6	4.73
MR RSKE/RSKM 750x700	717	745	770	730.6	767	780	820	780.6	4.89
MR RSKE/RSKM 800x700	717	745	770	730.6	817	830	870	830.6	5.05
MR RSKE/RSKM 850x700	717	745	770	730.6	867	880	920	880.6	5.21
MR RSKE/RSKM 900x700	717	745	770	730.6	917	930	970	930.6	5.37
MR RSKE/RSKM 950x700	717	745	770	730.6	967	980	1020	980.6	5.53
MR RSKE/RSKM 1000x700	717	745	770	730.6	1017	1030	1070	1030.6	5.69
MR RSKE/RSKM 750x750	767	795	820	780.6	767	780	820	780.6	5.05
MR RSKE/RSKM 800x750	767	795	820	780.6	817	830	870	830.6	5.21
MR RSKE/RSKM 850x750	767	795	820	780.6	867	880	920	880.6	5.37
MR RSKE/RSKM 900x750	767	795	820	780.6	917	930	970	930.6	5.53
MR RSKE/RSKM 950x750	767	795	820	780.6	967	980	1020	980.6	5.69
MR RSKE/RSKM 1000x750	767	795	820	780.6	1017	1030	1070	1030.6	5.85
MR RSKE/RSKM 800x800	817	845	870	830.6	817	830	870	830.6	5.37
MR RSKE/RSKM 850x800	817	845	870	830.6	867	880	920	880.6	5.53
MR RSKE/RSKM 900x800	817	845	870	830.6	917	930	970	930.6	5.69
MR RSKE/RSKM 950x800	817	845	870	830.6	967	980	1020	980.6	5.85
MR RSKE/RSKM 1000x800	817	845	870	830.6	1017	1030	1070	1030.6	6.01
MR RSKE/RSKM 850x850	867	895	920	880.6	867	880	920	880.6	5.69
MR RSKE/RSKM 900x850	867	895	920	880.6	917	930	970	930.6	5.85
MR RSKE/RSKM 950x850	867	895	920	880.6	967	980	1020	980.6	6.01
MR RSKE/RSKM 1000x850	867	895	920	880.6	1017	1030	1070	1030.6	6.17
MR RSKE/RSKM 900x900	917	945	970	930.6	917	930	970	930.6	6.01
MR RSKE/RSKM 950x900	917	945	970	930.6	967	980	1020	980.6	6.17
MR RSKE/RSKM 1000x900	917	945	970	930.6	1017	1030	1070	1030.6	6.33
MR RSKE/RSKM 950x950	967	995	1020	980.6	967	980	1020	980.6	6.33
MR RSKE/RSKM 1000x950	967	995	1020	980.6	1017	1030	1070	1030.6	6.49
MR RSKE/RSKM 1000x1000	1017	1045	1070	1030.6	1017	1030	1070	1030.6	6.65

Note: MR RSKE/RSKM frames not indicated in the table can be produced on request.

Mounting

- The damper is attached directly to the flange of the mounting frame by means of self-tapping screws.

FRAME MOUNTING METHODS

Sealing of the damper with an MR RSKE/RSKM mounting frame in the wall opening

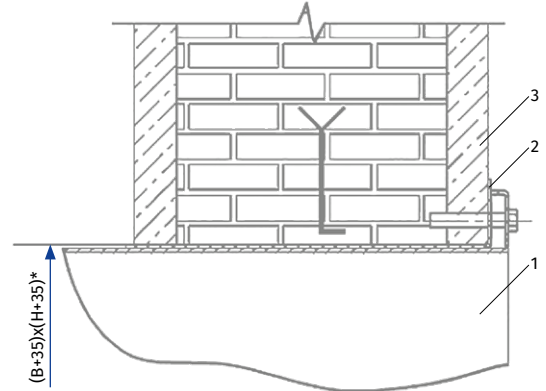

- 1 - damper
 - 2 - mounting frame
 - 3 - wall overlap, where
- B [mm] H [mm] – working section of the damper

*dimensions of the wall opening for the frame

SRFS

Aluminium decorative grille

Use

- For supply and exhaust ventilation, heating and air conditioning systems in industrial, commercial and domestic premises.



Design

- Made of high quality extruded aluminium profile.
- The polymer or anodized coating of the grille provides resistance to adverse weather conditions.
- Grilles with special dimensions can be manufactured upon request.
- Grilles from 450 mm in size are produced with an additional partition to provide rigidity (ONFS series).

Modifications

- Can be equipped with an adapter (A).
- Can be equipped with special springs (P) for quick installation.
- The unit can be equipped with a decorative grille made of aluminium for a more aesthetic appearance.
- The grille has a single horizontal row of non-adjustable air flow guides fixed at 45°.
- The grille is polymer coated and anodised for extra protection against the weather elements.
- To enable the decorative grille installation, the damper must be embedded at least 40 mm deep into the wall as measured from the wall face to the damper flange.

NOTE:

- While selecting the aluminium decorative grille mind the wall opening dimensions.

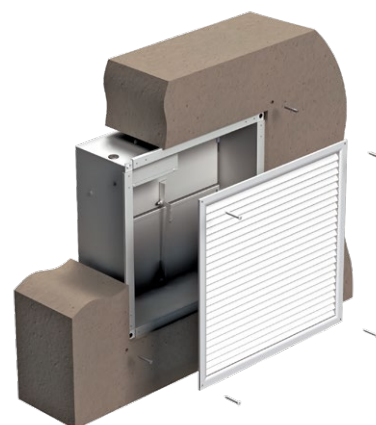

Designation key

Series:
Aluminium decorative grille

Opening dimensions: LxH (L – length [mm]; H – height [mm])
Length [mm]: 100; 150; 200; 250; 300; 350; 400; 450; 500; 600; 700; 800; 900; 1000
Height [mm]: 100; 150; 200; 250; 300; 350; 400; 450; 500; 600; 700; 800; 900; 1000

Grille fastening:
P: spring

Modifications:
_: no
A: adapter

Grille coating:
_: white colour
***colour*:** according to RAL
An: anodized
Zn: galvanized steel

SRFS X X X X

Pressure drop and sound power level

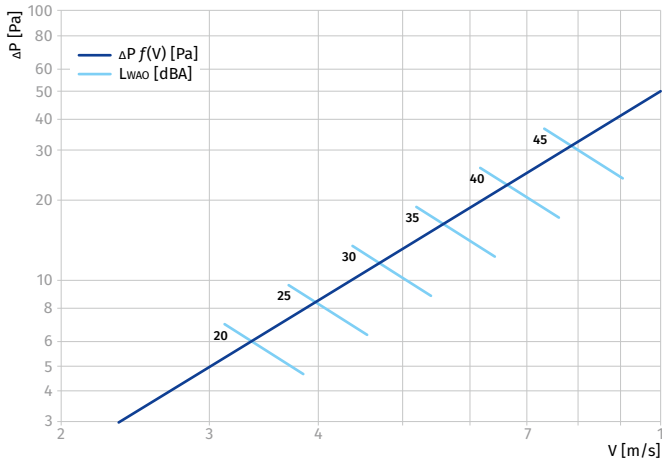

Calculation formula	Correction factor K							
$LWA = LWA0 \times K$	Scs [m ²]	0.005	0.01	0.02	0.03	0.05	0.07	1
	K [dBA]	-13	-9	-6	-4.5	-3	-1.5	0

Designation key:
 ΔP – pressure drop [Pa]
 LWA – sound power level [dBA]
 LWA0 – sound power level for cross-sectional area of 0.1 m² [dBA]
 K – correction factor for sound power level depending on cross-sectional area [dBA]
 Scs – cross-sectional area [m²]
 V – design speed [m/s]

Overall and mounting dimensions

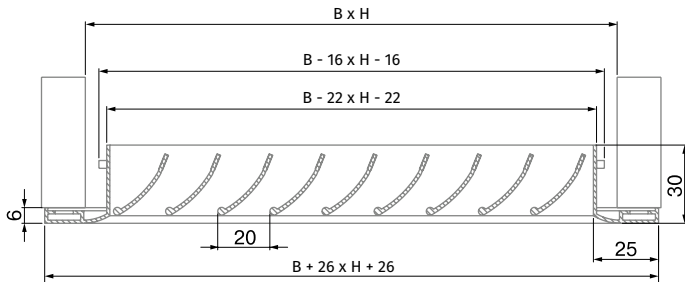

AIR FLOW DISTRIBUTION

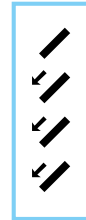

Deflection angle of air flow guides – 45°

Cross-section dimensions and area [m²]

Height H [mm]	Length L [mm]													
	100	150	200	250	300	350	400	450	500	600	700	800	900	1000
100	0.004	0.007	0.010	0.012	0.015	0.018	0.021	0.024	0.027	0.033	0.039	0.045	0.051	0.057
150	0.070	0.010	0.015	0.018	0.023	0.027	0.031	0.035	0.039	0.047	0.055	0.064	0.072	0.080
200	0.010	0.015	0.021	0.026	0.033	0.038	0.045	0.051	0.058	0.070	0.081	0.093	0.105	0.115
250	0.012	0.018	0.026	0.032	0.041	0.047	0.055	0.062	0.070	0.084	0.098	0.106	0.113	0.128
300	0.015	0.023	0.033	0.041	0.051	0.059	0.069	0.077	0.086	0.096	0.115	0.132	0.149	0.168
350	0.017	0.026	0.038	0.047	0.059	0.068	0.080	0.090	0.099	0.111	0.132	0.151	0.170	0.193
400	0.020	0.030	0.044	0.054	0.069	0.079	0.093	0.103	0.117	0.142	0.166	0.189	0.212	0.237
450	0.023	0.035	0.051	0.062	0.080	0.090	0.107	0.117	0.131	0.160	0.186	0.214	0.239	0.265
500	0.026	0.039	0.056	0.070	0.089	0.100	0.119	0.130	0.145	0.178	0.206	0.238	0.265	0.293
600	0.031	0.047	0.067	0.084	0.105	0.121	0.142	0.158	0.173	0.214	0.246	0.287	0.318	0.349
700	0.036	0.055	0.078	0.094	0.124	0.145	0.170	0.184	0.203	0.251	0.288	0.336	0.372	0.408
800	0.042	0.063	0.090	0.112	0.141	0.163	0.190	0.211	0.232	0.288	0.330	0.385	0.426	0.467
900	0.048	0.072	0.103	0.129	0.160	0.185	0.228	0.238	0.262	0.325	0.372	0.435	0.481	0.527
1000	0.053	0.079	0.113	0.141	0.177	0.204	0.239	0.266	0.292	0.361	0.414	0.484	0.536	0.587

FREQUENCY CONVERTERS

Operation of fans with frequency converters	186
Frequency converters Micro Drive FC-51	187
Frequency converters Basic Drive FC-101	188

Operation of fans with frequency converters

Ventilation systems produce a heavy load on the electrical systems of a building. Therefore, reducing the power consumption is among the top priorities for construction project designers.

DIRECT ON-LINE STARTING (DOL)

As a rule, smoke extraction systems utilize large high-performance fans. During starting the high inertia of the shaft causes a substantial increase in the start-up time – i.e. the time from the application of power to reaching the rated speed. As a result the motor is subjected to high starting current for a prolonged period of time.

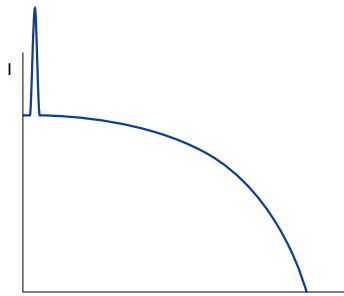

Current diagram with direct on-line starting

Standard switchgear (automatic circuit breakers, contactors and motor starters) is not designed to withstand prolonged overloads causing the fan to shut down automatically during starting.

Using switchgear with a higher maximum current rating renders the electric motor protection system less sensitive.

As a result the switchgear will not be able to detect motor overload in time due to a higher current sensing threshold.

Such challenges can only be addressed by utilizing a soft starter or a frequency converter to start the fan without causing a prolonged overload.

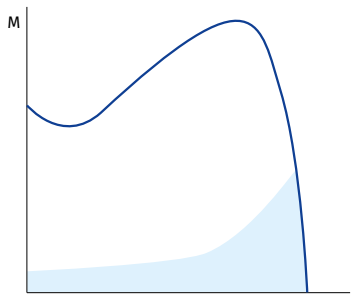

Torque diagram with direct on-line starting

FREQUENCY CONVERTER

A frequency converter (FC) consists of two main component blocks. One converts alternating current (50 or 60 Hz) into direct current.

The other converts direct current into alternating current of variable frequency ranging from 0 to 250 Hz.

By controlling the frequency output the FC offers a broad range of motor speed regulation.

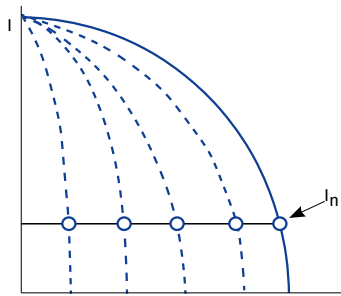

Current diagram with FC starting

During the starting the FC raises the frequency from 0 Hz to the electrical mains frequency (50 or 60 Hz).

As the frequency is increased gradually, the motor can be assumed to operate at its nominal speed for a given frequency value.

Furthermore, on the assumption that the motor runs at its nominal speed the nominal torque should be immediately available whereas the current will be approximately equal to the nominal value.

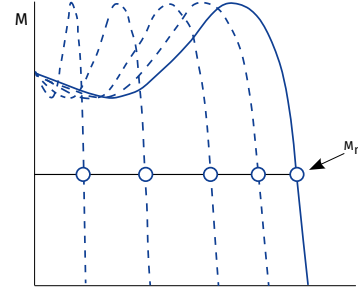

Torque diagram with FC starting

SOFT STARTER

Unlike an FC, a soft starter does not change the frequency of speed. Instead it gradually increases the voltage supplied to the motor – from the initial level to the nominal level.

The very low voltage initially supplied to the motor during starting helps avoid sudden jolts.

Both voltage and torque increase gradually.

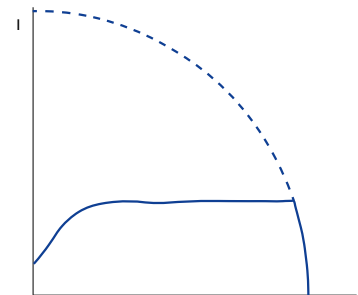

Current diagram with soft starter

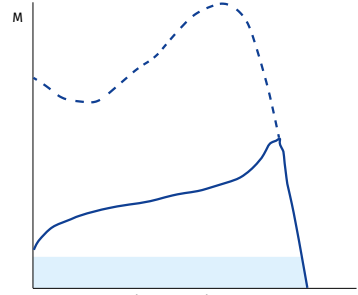

Torque diagram with soft starter

APPLICATIONS IN VENTILATION SYSTEMS

Using an FC or a soft starter allows to reduce the starting current thereby avoiding a loss of voltage in the electrical mains.

In addition to that the starting torque and mechanical strain on equipment are also reduced which translates into extended maintenance and repair intervals. General exhaust ventilation (GV) systems and emergency smoke extraction (SE) systems of car parks, warehouses, utility and industrial spaces can be integrated into a single system at the design level.

As the air flow rate a GV system is considerably lower than that in an SE system a high-capacity fan rated for smoke extraction duty runs in partial load mode.

Frequency converters can be programmed for several fixed-speed settings to enable operation in GV and SE modes.

The fan operating modes can be switched upon receiving an external signal from the control system.

Such integration of ventilation systems allows overall cost savings.

FC-51 AND FC-101: WHEN TO USE?

This catalogue features two series of frequency converters: FC-51 and FC-101.

The FC-51 series is only suitable for general ventilation systems.

If intended for a smoke extraction system, the fans should be fitted with the FC-101 series units as they feature an integrated fire mode.

When activated the integrated protection equipment of the frequency converter is overridden enabling the unit to continue operation despite the possibility of sustaining irreparable damage due to overheating or overloading.

In case of a fire, the FC-101 series frequency converters are capable of maintaining a higher air pressure level at landings compared to other areas of the building in order to keep the landings smoke-free.

MICRO DRIVE FC-51

Frequency converters

Use

- o This general-purpose variable frequency drive is designed for regulating the rotation speed of an AC electric motor with a maximum power output of 22 kW.
- o This unit is only suitable for general ventilation systems.



Features

- o The drive construction prevents forced air flow passage through its internal electronic components.
- o The internal circuit boards are well-protected.

Filter

- o The unit features an integrated HF filter which blocks RF interference from the motor and enables the use of a shielded cable up to 15 m long or unshielded cable up to 50 m long as per the applicable EU regulations.

Inputs and outputs

- o 5 programmable digital inputs
- o PNP/NPN logic
- o 20-5000 Hz pulse input
- o One 0-10 V or 0-20 mA analogue input
- o One 0-20 mA analogue input
- o Thermistor input (analogue or digital)
- o 1 analogue output
- o 1 relay, 240 V, 2 A
- o RS 485
- o MODBUS RTU

Control panels



Designation	Code
VLT control panel LCP 11 (without potentiometer)	132B0100
VLT Control Panel LCP 12 (with potentiometer)	132B0101



Designation	Code
Remote panel mounting kit	132B0102

Installation

- o Back-to-back installation for space savings. Thanks to a compact design the drives can be mounted immediately next to one another without any performance penalties.

Frequency converter type and order code

Three-phase, 380-480 V			
Power [kW]	Rated current [A]	Order code	Block type
0.37	1.2	132F0017	M1
0.75	2.2	132F0018	M1
1.5	3.7	132F0020	M2
2.2	5.3	132F0022	M2
3.0	7.2	132F0024	M3
4.0	9.0	132F0026	M3
5.5	12.0	132F0028	M3
7.5	15.5	132F0030	M3
11.0	23.0	132F0058	M4
15.0	31.0	132F0059	M4
18.0	37.0	132F0060	M5
22.0	43.0	132F0061	M5

Outside dimensions (including mounting ledge)

mm	M1	M2	M3	M4	M5
Height	150	176	239	292	335
Width	70	75	90	125	165
Depth	148	168	194	241	248

+ 6 mm with potentiometer

BASIC DRIVE FC-101

Frequency converters



Use

- This general-purpose variable frequency drive is designed for regulating the rotation speed of an AC electric motor with a maximum power output of 90 kW.
- This drive is suitable for both general ventilation and smoke extraction ventilation systems.

Certified fire mode

- The fire mode prevents the drive from a self-protecting shut-down. While in this mode the drive continues to perform speed regulation duty for mission-critical fans irrespective of control signals, warnings and alarms which may otherwise force it shut down.

Filter

- A built-in throttle on the DC link ensures a low harmonic load on the power mains as per the EN 61000-3-12 standard requirements.

Inputs and outputs

- Four PNP or NPN programmable digital inputs, 0-24 V DC
- 2 analogue inputs (0-10 V or 0/4-20 mA)
- 2 analogue outputs (0/4-20 mA)
- 2 relay outputs
- MODBUS RTU (RS 485)
- BACnet MSTP
- FC Protocol
- N2 Metasys
- FLN Apogee

Installation

- Thanks to an ultra-compact design the drive can be easily fitted into a larger unit or panel of an air ventilation system. The casings are rated IP20/Type 1/IP21 (optional) and IP54.

Frequency converter type and SKU code

Power [kW]	Current [A]	VLT® FC 101 HVAC Basic Drive 0.37-90 kW (3 x 380 – 480 V~, without a braking transistor)			
0.37	1.2	-	131L9861	-	-
0.75	2.2	-	131L9862	131N0177	131N0178
1.5	3.7	-	131L9863	131N0179	131N0180
2.2	5.3	-	131L9864	131N0181	131N0182
3	7.2	-	131L9865	131N0183	131N0184
4	9.1	-	131L9866	131N0185	131N0186
5.5	12	-	131L9867	131N0187	131N0188
7.5	15.5	-	131L9868	131N0189	131N0190
11	23	-	131L9869	131N0191	131N0192
15	31	-	131L9870	131N0193	131N0194
18	37	-	131L9871	131N0195	131N0196
22	42.5	-	131L9872	131N0197	131N0198
30	61	131L9873	131L9875	131N0201	131N0202
37	73	131L9881	131L9883	131N0205	131N0206
45	90	131L9889	131L9891	131N0209	131N0210
55	106	131L9897	131L9899	131N0213	131N0214
75	147	131L9905	131L9907	131N0217	131N0218
90	177	131L9913	131L9915	131N0221	131N0222
Casing	(E20) IP20/Chassis	(E20) IP20/Chassis	IP54	IP54	IP54
EMC filter	(H2) RFI class A2 (for industrial areas)	(H3/H4) RFI class A1/B (for residential areas)	(H2) RFI class A2 (for industrial areas)	(H3) RFI class A1/B (for residential areas)	(H3) RFI class A1/B (for residential areas)
Control panel	(X) without panel	(X) without panel	Integral	Integral	Integral

VLT® HVAC Basic frequency converters rated up to 22 kW are fitted with circuit boards with a special class 3C3 protective coating. For frequency converters rated higher than 22 kW this protective coating is optional while, the 3C2 coating is standard.

VLT® FC 101 HVAC Basic Drive frequency converter options

Order code	Description
132B0200	Operator's digital panel
132B0201	Kit for remote mounting of the operator panel to an IP55 cabinet, including 3 m cable
132B0202	Decoupling plate for H1 and H2 standard sizes
132B0204	Decoupling plate for H3 standard size
132B0205	Decoupling plate for H4 and H5 standard sizes
132B0207	Decoupling plate for H6 standard size
132B0242	Decoupling plate for H6 standard size (extra large)

Order code	Description
132B0208	Decoupling plate for H7 standard size
132B0243	Decoupling plate for H7 standard size (extra large)
132B0209	Decoupling plate for H8 standard size
132B0244	External EMC filter class A1/B1 for power output from 0.37 to 2.2 kW
132B0245	External EMC filter class A1/B1 for power output from 3 to 7.5 kW
132B0246	External EMC filter class A1/B1 for power output from 11 to 15 kW
132B0247	External EMC filter class A1/B1 for power output from 18.5 to 22 kW

Blauberg Ventilatoren GmbH
Aidenbachstr. 52
D-81379 Munich

info@blaubergventilatoren.de
www.blaubergventilatoren.de

Technical changes reserved.
Illustrations and texts are non-binding.

06/2020