



SUPPLY VENTILATION UNIT



BLAUBOX E



EN

OPERATION MANUAL

CONTENTS

3	Introduction
3	General
3	Safety rules
3	Transportation and storage rules
3	Manufacturer's warranty
4	Design
4	Delivery set
5	Technical data
7	Mounting
8	Connection to power mains
11	Control panel mounting
12	Unit control
17	Troubleshooting and fault handling
18	Technical maintenance
19	Acceptance certificate
19	Connection certificate
19	Warranty card

BLAUBERG Ventilatoren GmbH is happy to offer your attention the supply ventilation unit BLAUBOX E.

INTRODUCTION

The present operation manual contains a technical description, technical data sheets, operation and mounting guidelines, safety precautions and warnings for safe and correct operation of the unit.

Read carefully and understand the operation manual, especially the safety requirements, before the unit mounting and start up.

Keep the operation manual available as long as you use the unit.

GENERAL

The supply ventilation unit BLAUBOX E is designed for efficient and energy saving ventilation of domestic and public premises. The unit ensures controllable air supply, filtering and heating.

The unit is not a ready to use product but a component part of central air conditioning and ventilation network.

The unit is rated for indoor application at ambient temperature from +1 °C up to +40 °C and relative humidity not exceeding 80% .

Hazardous parts access and water ingress protection rating:

- unit motor - IP 44;
- assembled unit connected to air ducts - IP 22.

The design of the units is regularly improved, so some models can slightly differ from those ones described in this service instruction.

SAFETY RULES

All operations related to the unit electrical connections, servicing and repair works are allowed only after the unit disconnection from power mains.

The unit is rated as a Class I electrical appliance.

All mounting and servicing operations are allowed by duly qualified personnel.

Please follow the safety regulations and working instructions (DIN EN 50 110, IEC 364).

Make sure the impeller and the casing are not damaged before connecting the unit to power mains. The casing internals must be free of any foreign objects which can damage the impeller blades or the motor.

The unit maintenance and repair is allowed only after power cut-off and full stop of the rotating parts.

Misuse of the unit or any unauthorized modification are not allowed.

The appliance is designed for connection to power mains in compliance with the «Technical Data» table.

The unit is rated for permanent operation.

Take steps to prevent ingress of smoke, carbon monoxide and other combustion products into the room through open chimney flues or other fire-protection devices. Sufficient air supply must be provided for proper combustion and exhaust of gases through the chimney of fuel burning equipment to prevent back drafting. The maximum permitted pressure

difference per living units is 4 Pa.

The transported air must not contain any dust or other solid impurities, sticky substances or fibrous materials.

The unit is not rated for operation in a flammable or explosive medium.

Fulfill the operation manual requirements to ensure a trouble-free and long service life of the unit.

TRANSPORTATION AND STORAGE RULES

Transportation of the unit is allowed by any vehicle provided the unit is transported in the original package and is protected against weather and mechanical damages.

Use hoist machinery for handling and transportation to prevent possible mechanical damages of the unit. Fulfill the requirements for transportation of the specified cargo type during cargo-handling operations.

Store the unit in a dry and cool place in the original package.

The storage environment must not be subjected to any aggressive and/or chemical evaporations, admixtures, foreign objects that may provoke corrosion and damage connection tightness.

Store the unit in an environment with minimized risk of mechanical damages, temperature and humidity fluctuations.

Do not expose the unit to the temperatures below +5 °C and above +40 °C.

Connection of the unit to power mains is allowed after the unit has been kept indoor for minimum two hours.

MANUFACTURER'S WARRANTY

The unit complies with the requirements according to the EU norms and directives, to the relevant EU-Low Voltage Equipment Directives, EU-Directives on Electromagnetic Compatibility.

We hereby declare that the unit complies with the essential protection requirements of Electromagnetic Council Directive 2004/108/EC, 89/336/EEC and Low Voltage Directive 2006/95/EC, 73/23/EEC and CE-marking Directive 93/68/EEC on the approximation of the laws of the Member States relating to electromagnetic compatibility, which relate to electrical appliances used in set voltage classes.

The manufacturer hereby warrants normal operation of the unit over the period of two years from the retail sale date provided observance of the installation and operation regulations.

In case of failure due to manufacturing fault during the warranty period the consumer has the right to exchange it.

The replacement is offered by the Seller.

In case of no confirmation of the sale date, the warranty period shall be calculated from the manufacturing date.

The MANUFACTURER is not responsible for any damage resulting from any misuse of or gross mechanical interference with the unit.

The MANUFACTURER is not responsible for the damages resulted due to the use of third party equipment or to third party equipment.



WARNING

The unit is not allowed for use by children and persons with reduced physical, mental or sensory capacities, without proper practical experience or expertise, unless they are controlled or instructed on the product operation by the person(s) responsible for their safety.

Supervise the children and do not let them play with the product.



WARNING

Do not dispose in domestic waste.

The unit contains in part materials that can be recycled and in part substances that should not end up as domestic waste.

Dispose of the unit once it has reached the end of its working life according to the regulations valid in your country.

DESIGN

The casing is made of double-skinned aluzinc panels, internally filled with 25 mm mineral wool layer for heat- and sound-insulation.

The casing has mounting brackets with anti-vibration rubber mounts for easy installation. The spigots for connection to the air ducts are located at the side of the unit and are equipped with rubber seals for airtight connection to the air ducts.

The hinged side panel ensures easy access to the internals for service works including cleaning, filter replacement, etc.

Asynchronous external rotor motor and centrifugal impeller with backward curved blades is used for air supply. The motor is available in a single- or three-phase motor modification depending on the fan model type.

The motor is equipped with integrated overheating protection with automatic restart and ball bearings for a long service life.

The units have an electric heater for operation during cold seasons at low outside temperature. The electric heater is equipped with integrated overheat protection thermostats, one actuated at +60 °C with automatic restart and the other one actuated at +90 °C with manual restart.

The built-in G4 cassette filter ensures efficient filtration of supply air. Filter clogging is controlled by the differential pressure sensor.

The unit incorporates an integrated control system with a wall-mounted control panel and LCD display. The standard delivery set includes a 10 m cable for connection of the unit to the control panel.

The unit is equipped with a duct temperature sensor for temperature control and maintenance. The power switch is located on the control unit and is used to disconnect the unit from power mains.

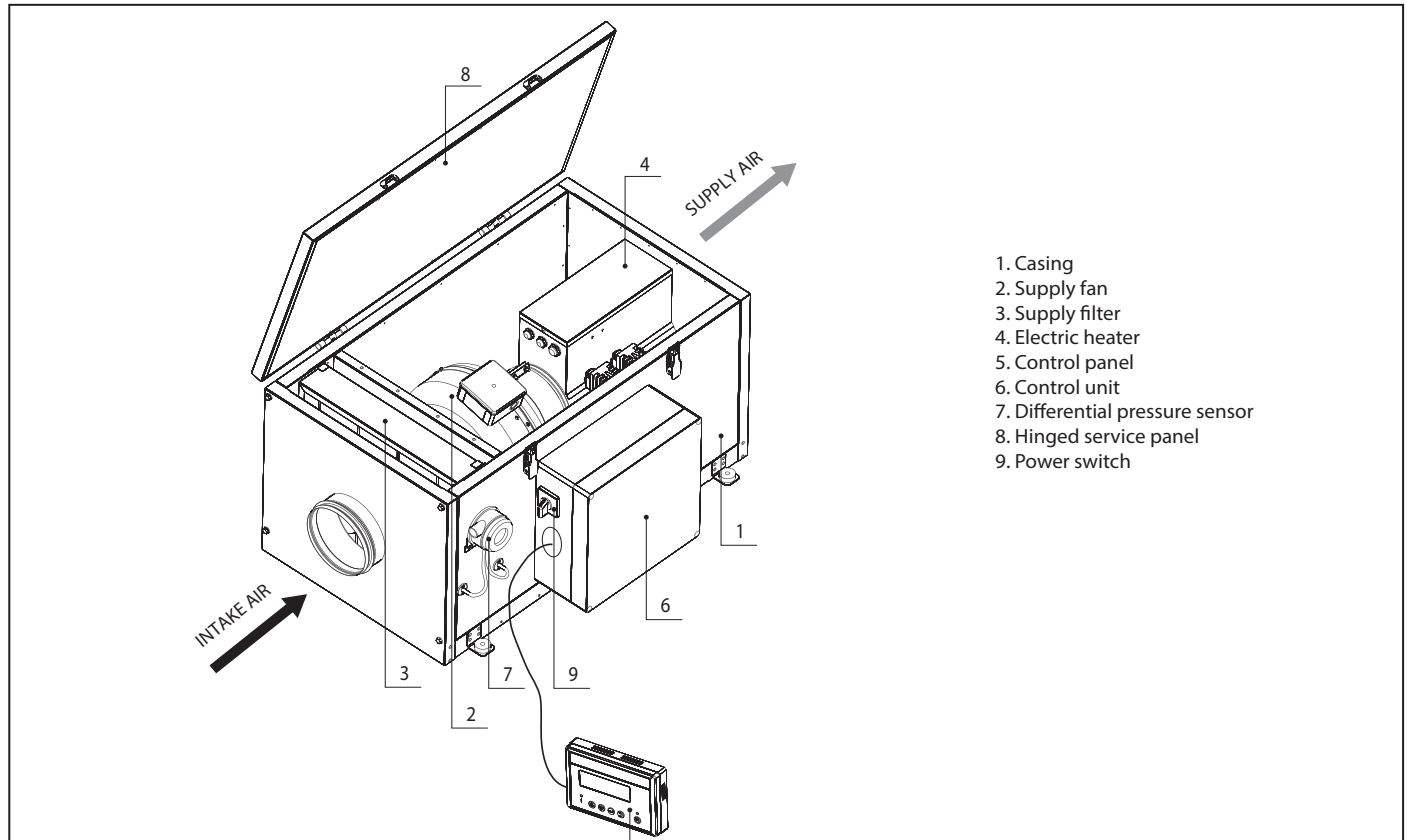

Fig. 1. Unit design and operating logic

DELIVERY SET

- ✓ Unit - 1 item;
- ✓ Operation manual - 1 item;
- ✓ Wall-mounted control panel - 1 item;
- ✓ Packing box - 1 item.



ATTENTION

Make sure the unit has no visible transport damages while accepting the goods. Check the ordered and the delivered goods for compliance.

TECHNICAL DATA

Table 1. Technical data of the unit

Parameters	BLAUBOX E200-1.8	BLAUBOX E300-2.4	BLAUBOX E400-2.4	BLAUBOX E400-3.4	BLAUBOX E400-5.1	BLAUBOX E400-6	BLAUBOX E800-3.4	BLAUBOX E800-5.1
Unit voltage [V /50 Hz]	1~ 230				3~ 400		1~ 230	3~400
Fan power [kW]	0,073	0,075	0,098			0,193		
Fan current [A]	0,32	0,33	0,43			0,84		
Electric heater power [kW]	1,8	2,4	2,4	3,4	5,1	6,0	3,4	5,1
Electric heater current [A]	7,8	10,4	10,4	14,8	7,4	8,7	14,8	7,4
Number of electrical heating elements	3	3	2	2	3	3	2	3
Total unit power [kW]	1,873	2,475	2,498	3,498	5,198	6,098	3,593	5,293
Total unit current [A]	8,12	10,73	10,83	15,23	7,83	9,13	15,64	8,24
Air capacity [m ³ /h]	190	285	425			810		
RPM	2830	2800	2705			2780		
Sound pressure level at 3 m [dBA]	27	28	29			30		
Transported air temperature [oC]	-25 up to +55						-25 up to +45	
Casing material	aluzinc							
Insulation	25 mm mineral wool							
Supply filter	cassette G4							
Connected air duct diameter [mm]	100	125	150			200		
Weight [kg]	50						52	

Parameters	BLAUBOX E800-6	BLAUBOX E1000-3.6	BLAUBOX E1000-6	BLAUBOX E1000-9	BLAUBOX E1200-6	BLAUBOX E1200-9	BLAUBOX E1500-6	BLAUBOX E1500-9
Unit voltage [V /50 Hz]	3~400							
Fan power [kW]	0,193	0,194			0,171		0,296	
Fan current [A]	0,84	0,85			0,77		1,34	
Electric heater power [kW]	6,0	3,6	6,0	9,0	6,0	9,0	6,0	9,0
Electric heater current [A]	8,7	5,3	8,7	13,0	8,7	13,0	8,7	13,0
Number of electrical heating elements	3	3	3	3	3	3	3	3
Total unit power [kW]	6,193	3,794	6,194	9,194	6,171	9,171	6,296	9,296
Total unit current [A]	9,54	6,15	9,55	13,85	9,47	13,77	10,04	14,34
Air capacity [m ³ /h]	810	990			1190		1520	
RPM	2780	2790			2600		2720	
Sound pressure level at 3 m [dBA]	30							
Transported air temperature [oC]	-25 up to +45	-25 up to +50					-25 up to +45	
Casing material	aluzinc							
Insulation	25 mm mineral wool							
Supply filter	cassette G4							
Connected air duct diameter [mm]	200	250			315			
Weight [kg]	52				62			

Table 2. Accessories

Model	Replaceable G4 filter (cassette)
BLAUBOX E200-1.8	FP-E200-300 G4
BLAUBOX E300-2.4	
BLAUBOX E400-2.4	FP-E400 G4
BLAUBOX E400-3.4	
BLAUBOX E400-5.1	
BLAUBOX E400-6	
BLAUBOX E800-3.4	
BLAUBOX E800-5.1	FP-E800-1000 G4
BLAUBOX E800-6	
BLAUBOX E1000-3.6	
BLAUBOX E1000-6	
BLAUBOX E1000-9	
BLAUBOX E1200-6	FP-E1200-1500 G4
BLAUBOX E1200-9	
BLAUBOX E1500-6	
BLAUBOX E1500-9	

Таблица 3. Габаритные размеры

Model	Dimensions [mm]					
	D	B	B1	H	L	L1
BLAUBOX E200-1.8	99	382	421,5	408	800	647
BLAUBOX E300-2.4	124	382	421,5	408	800	647
BLAUBOX E400-2.4 BLAUBOX E400-3.4 BLAUBOX E400-5.1 BLAUBOX E400-6	149	455	496,5	438	800	647
BLAUBOX E800-3.4 BLAUBOX E800-5.1 BLAUBOX E800-6	199	487	526,5	513	835	684
BLAUBOX E1000-3.6 BLAUBOX E1000-6 BLAUBOX E1000-9	249	487	526,5	513	835	684
BLAUBOX E1200-6 BLAUBOX E1200-9 BLAUBOX E1500-6 BLAUBOX E1500-9	314	527	566,5	548	900	750

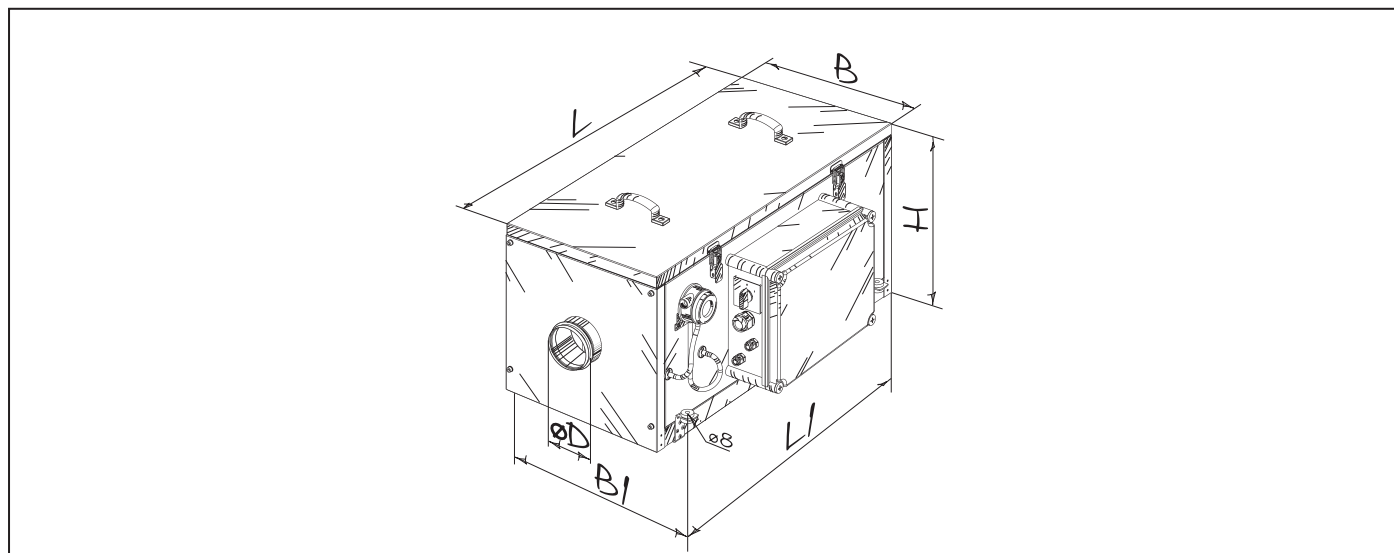

Fig. 2. Overall dimensions

MOUNTING

**WARNING****Safety precautions:**

The unit must be mounted to a rigid and stable structure. The unit must be suspended using anchor bolts. Before starting mounting check that the mounting structure has sufficient loading capacity for the unit weight. The unit mounting is allowed only after power cut-off and full stop of the rotating parts.

Restrictions:

Do not operate the unit beyond the determined temperatures, in aggressive and in explosive medias. Do not connect the clothes dryer or other similar equipment to the ventilation system. Do not use the unit for air/dust mixture handling.

The unit mounting position must provide access to the terminal box for electric connection and access to the service panel for maintenance and filter replacement.

The unit must be mounted to a smooth-faced surface. Mounting of the unit to an uneven surface results in the unit casing distortion and will prevent the unit proper functioning.

While planning the ductwork layout avoid too long air duct sections, numerous bends and reducers because it may reduce air flow.

The mounted air ducts must not be deformed.

Provide airtight connection of the air ducts to the unit spigots and fittings.

While mounting the unit install a ventilation grille, an outer hood, a disk

valve or any other protecting device at the outlet of the air ducts with a mesh width not exceeding 12.5 mm.

Mounting on a horizontal plane (Fig. 3).

Fix the unit on a rigid and stable horizontal plane.

Suspended mounting (Fig. 4).

Before starting mounting check that the mounting structure has sufficient loading capacity for the unit weight.

The unit must be rigidly fixed!

Loose fixation of the unit may result in noise and vibration generation.

The unit is suspended to the ceiling with four M8 anchor bolts, the matching dowels, nuts and washers.

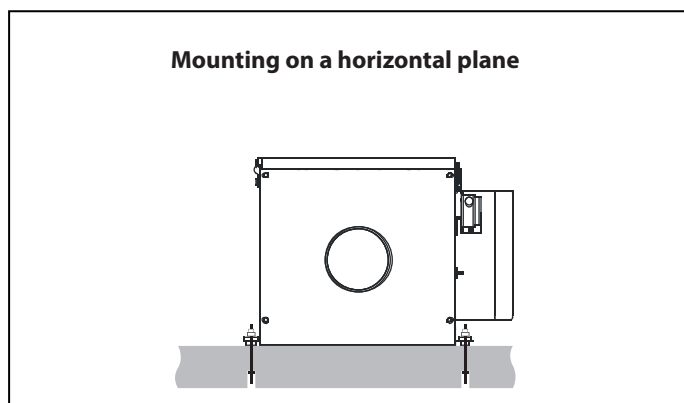

Fig. 3. Mounting on a horizontal plane

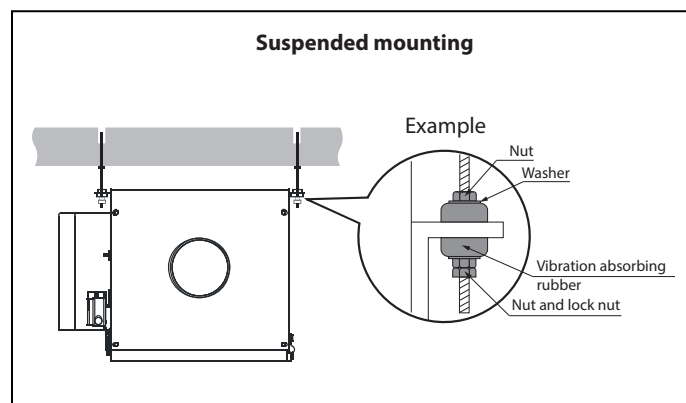

Fig. 4. Suspended mounting

Duct temperature sensor mounting (Fig. 5).

Install the duct temperature sensor at least 2 m away from the supply air duct end in a place with the balanced temperature conditions around the sensor (Fig. 5).

The duct temperature sensor is pre-wired to the control unit via the supplied 4 m cable (X1:8, X1:9 contacts on the terminal box, irrespective of polarity).

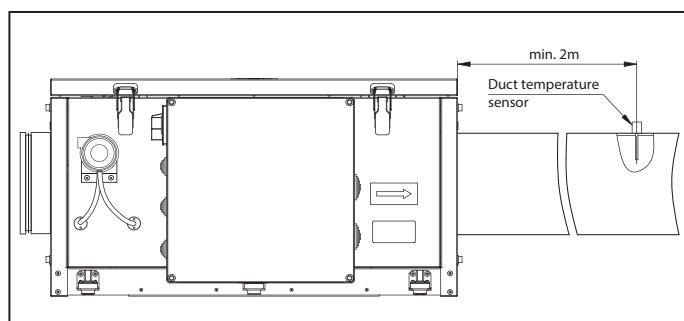

Fig. 5. Duct temperature sensor mounting

Differential pressure sensor.

Differential pressure sensor is delivered installed on the casing of the unit. To avoid possible operation malfunctions of the unit make sure that the rubber tube upstream of the filter is connected to the R1 sensor lead and the rubber tube downstream of the filter - to the R2 sensor.

According to the factory setting, the sensor is activated at the pressure difference 200 Pa. The operating pressure range is from 50 up to 500 Pa.

CONNECTION TO POWER MAINS



WARNING

Read the operation manual prior to any electric installations. Connection of the unit to power mains is allowed by a qualified electrician only. The rated electrical parameter are stated on the rating plate. No modifications of internal connections are allowed and will result in void warranty. Connect the unit only to power mains with valid electric standards.

Follow the respective electric standards, safety rules (DIN VDE 0100), TAB der EVUs. The house cabling system must be equipped with a magnetic trip automatic switch at the external input. The contact gap on all poles must be at least 3 mm (VDE 0700 T1 7.12.2 / EN 60335-1). The automatic switch trip current must be not below the rated current consumption (ref. Table 1). Enable quick access to a mounting location of the automatic switch.

Cut power supply to the unit off by turning the automatic electric switch QF to OFF position prior to any operations.

Take steps to prevent activation of the automatic switch before finishing all the operations.

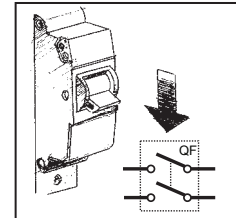

Depending on the model the unit is rated for connection to 230 V / 50 Hz single-phase alternating current power mains or to 400 V / 50 Hz three-phase alternating power mains (ref. Tab. 1) via insulated, durable and heat-resistant conductors (cables, wires) with a matching cross section (ref. Table 4).

The referred conductor cross section is for reference only. While selecting the conductors with respective cross section consider the wire type, the maximum permissible conductor heating temperature, its insulation, length and layout.

Use copper wires only.

The unit must be grounded in compliance with the valid electrical standards of the user country!

Connect the unit to power mains through the terminal block located in the terminal box following the wiring diagram and the terminal designation (ref. Fig. 6).

Connect all the control and power cables in compliance with the terminal marking and polarity!

The rating plate with a terminal designation is placed inside of the terminal box.

Route the cables into the control unit through the electric lead-in on the unit panel to preserve the electrical protection class.

Table 4. Unit connection

Model	Automatic switch	Copper cable
BLAUBOX E200-1.8	230 V; 10 A	3x2,5
BLAUBOX E300-2.4	230 V; 16 A	3x2,5
BLAUBOX E400-2.4	230 V; 16 A	3x2,5
BLAUBOX E400-3.4	230 V; 25 A	3x2,5
BLAUBOX E400-5.1	400 V; 10 A	5x2,5
BLAUBOX E400-6	400 V; 16 A	5x2,5
BLAUBOX E800-3.4	230 V; 25 A	3x2,5
BLAUBOX E800-5.1	400 V; 10 A	5x2,5
BLAUBOX E800-6	400 V; 16 A	5x2,5
BLAUBOX E1000-3.6	400 V; 10 A	5x2,5
BLAUBOX E1000-6	400 V; 16 A	5x2,5
BLAUBOX E1000-9	400 V; 25 A	5x2,5
BLAUBOX E1200-6	400 V; 16 A	5x2,5
BLAUBOX E1200-9	400 V; 25 A	5x2,5
BLAUBOX E1500-6	400 V; 16 A	5x2,5
BLAUBOX E1500-9	400 V; 25 A	5x2,5

Single-phase power mains

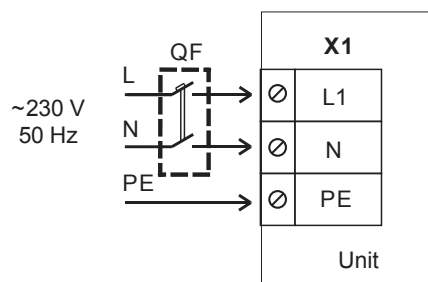

Three-phase power mains

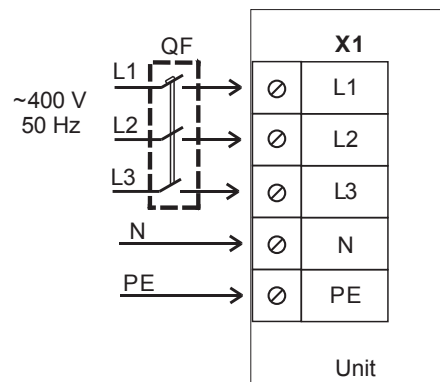

Fig. 6. Electric wiring diagram

Control unit.

The control unit is available in several modifications: 230 V / 50 Hz for single-phase power mains (Fig. 7) or 400V / 50 Hz for three-phase power mains (Fig. 8). Possible external connections to the control unit are shown in the respective figures. Not all the terminals may be used for electric connection, depending on a unit model.

All the circuits are connected to the two terminal blocks located in the control unit (ref. Fig. 7, 8). The fan, the heater, the opto-triac control unit, the control panel, the duct temperature sensor, the differential pressure sensor are pre-wired by the manufacturer. The unit has extra electric connection options.

- contact for connection of a fire extinguishing system;
- contact for connection of a humidity sensor.

While connecting the automatic fire extinguishing system remove the jumper between the X1:17 and X1:18 terminals of the X1 terminal block. In case of fire a normally closed dry contact breaks the control circuit and cuts off power supply to the unit.

Connect the humidity sensor to the X1:19, X1:20 terminals of the X1 terminal block. If the sensor is activated, the normally opened dry contact closes and switches the unit to maximum speed. Extra contacts must be connected by the user. Design of the X1 terminal block and the contacts for external connections are shown in Fig. 7,8.

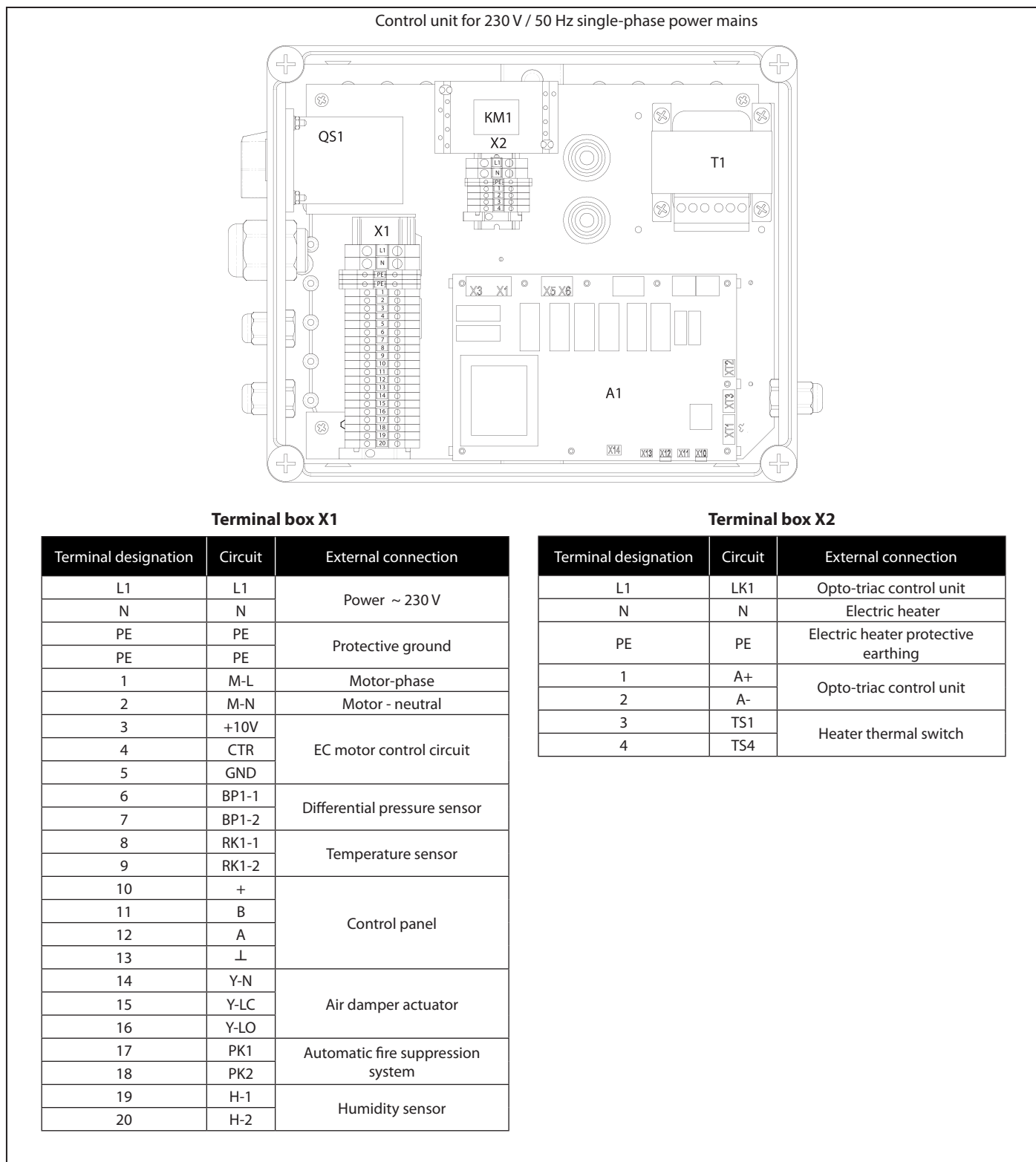
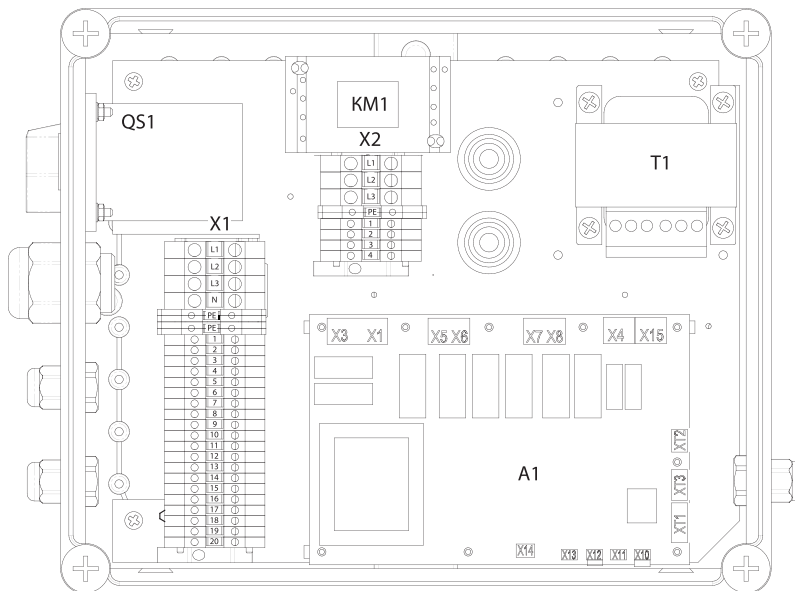

Fig. 7. Control unit for single-phase power mains

Control unit for 400 V / 50 Hz three-phase power mains



Terminal box X1

Terminal designation	Circuit	External connection
L1	L1	Power ~ 400 V
L2	L2	
L3	L3	
N	N	Neutral
PE	PE	Protective ground
PE	PE	
1	M-L	Motor - phase
2	M-N	Motor - neutral
3	+10V	EC motor control circuit
4	CTR	
5	GND	
6	BP1-1	Differential pressure sensor
7	BP1-2	
8	RK1-1	Temperature sensor
9	RK1-2	
10	+	Control panel
11	B	
12	A	
13	⊥	
14	Y-N	Air damper actuator
15	Y-LC	
16	Y-LO	
17	PK1	Automatic fire suppression system
18	PK2	
19	H-1	Humidity sensor
20	H-2	

Terminal box X2

Terminal designation	Circuit	External connection
L1	LK1	Opto-triac control unit
L2	LK2	
L3	LK3	
PE	PE	Electric heater protective earthing
1	A+	Opto-triac control unit
2	A-	
3	TS1	Heater thermal switch
4	TS4	

Fig. 8. Control unit for three-phase power mains

CONTROL PANEL MOUNTING

The control panel incorporates a room temperature sensor. The control panel must be located at least 1 m away from the heating appliances, doors and windows.

Fix the control panel on the wall with supplied screws. Connect the control panel to the unit via the supplied four-wire data cable, max. 10 m. Do not route the data cable between the control panel and the unit close to power cables, keep the minimum distance 150 mm.

The connections to the controller circuit board are shown in Fig. 9.

The control panel is supplied assembled and pre-wired to the unit. In case of the control panel re-assembly follow this sequence:

1. Disassemble the control panel (ref. Fig. 9):
 - 1.1 unlatch and open the control panel case;
 - 2.1 disconnect the cable from the terminal block using a screwdriver;
 - 3.1 remove the data cable.
2. Route the cable to the control panel installation place.
3. Install the control panel as follows (ref. Fig. 10):
 - 3.1. route the cable through the opening in the bottom cover;
 - 3.2. fix the bottom cover of the control panel in the installation place.

The screw head must not be in contact with the control panel circuit board, otherwise the equipment may be damaged!

- 3.3. strip the cable for ~20 mm;
- 3.4. strip the wires for ~6 mm;
- 3.5. connect the wires to the terminal block in the circuit board in

compliance with the designations and the wire colour:

yellow	+	(connected to X1:10 contact)
green	B	(connected to X1:11 contact)

brown	A	(connected to X1:12 contact)
white	⊥	(connected to X1:13 contact)

3.6. press the latches to close the control panel cover.

4. Route the cable through the cable lead-in in the control panel case and connect the wires to the contacts in the terminal block (Fig. 7,8).

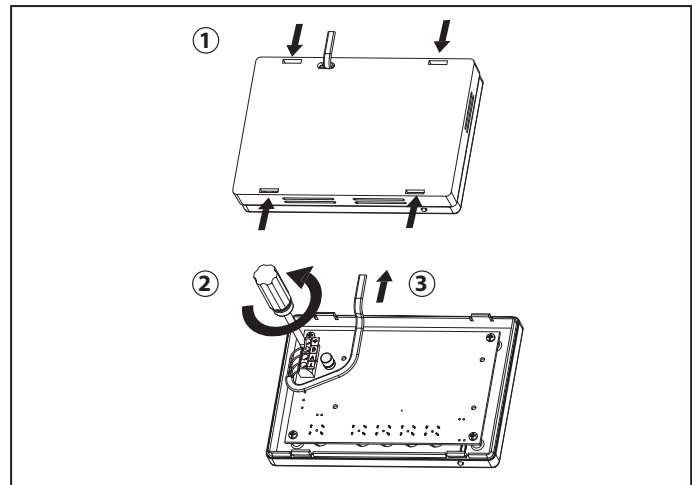

Fig. 9. Control panel shutdown

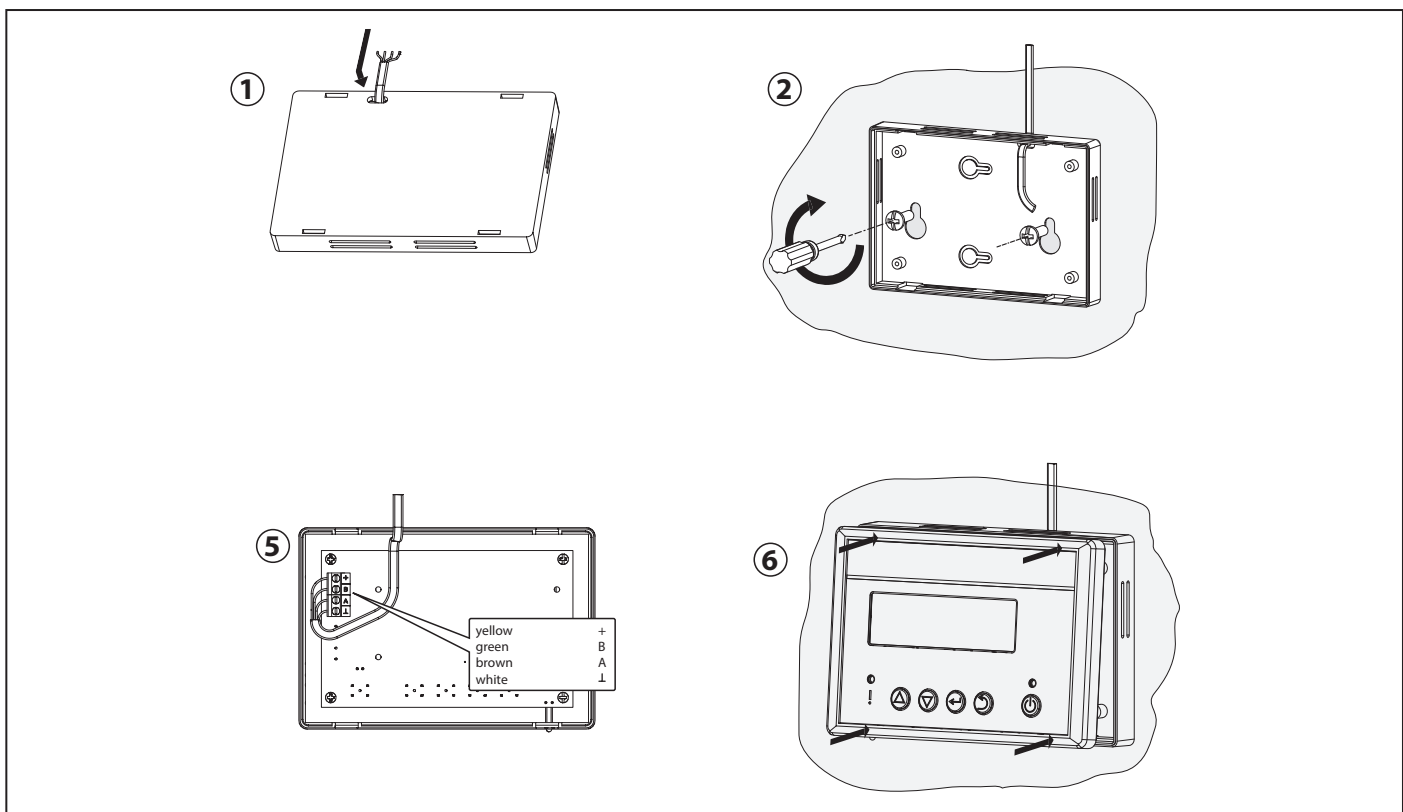

Fig. 10. Control panel mounting

UNIT CONTROL

The unit is controlled via a wall-mounted control panel, Fig. 11. The «control panel-unit» communication circuit is presented with a four-wire data cable up to 10 m.

□ The control system controls the air flow of the supply fan in three speed stages:

- low speed is used for ventilation in non-residential premises during weekend or in residential premises during night time.
- medium speed is used for the regular ventilation mode.
- high speed is used for high-power ventilation with extra air flow.

□ The temperature sensors are used for correct selection of the operation mode and maintaining set air temperature in the air duct.

□ The temperature sensor is integrated into the control panel and is used to maintain the set indoor temperature at set air flow or in compliance with the selected service function, see below. The correct operation mode selection as well as indication of the current parameters as indoor temperature, set temperature, fan speed stage, heater power are displayed on the LCD display.

□ The program of the balanced energy saving calculates the heater capacity required to maintain indoor air temperature with accuracy up to 1 °C

and heating output control with accuracy up to 1%.

□ The control system monitoring program is used to track the operation parameters. In case of emergency like heater overheating, communication circuit break, the control system is cut off and the alarm information is displayed on the control panel. The filter replacement warning is shown on the display with set periodicity (see below).

□ All user settings are saved in the non-volatile storage of the control panel.

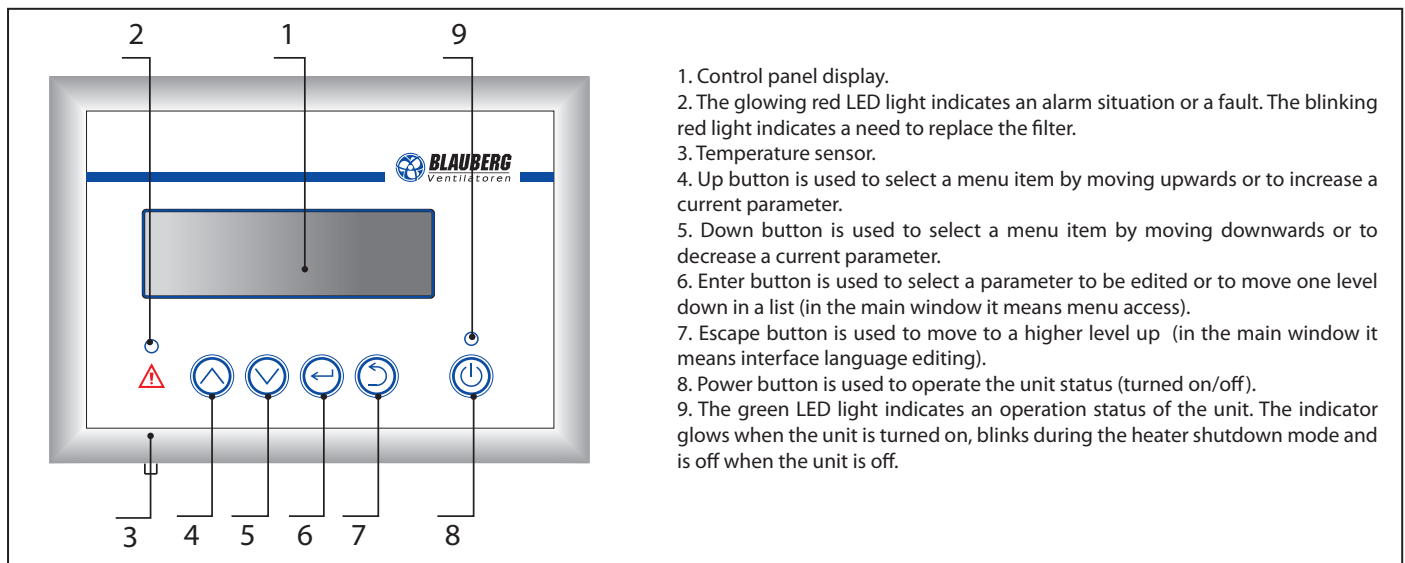

1. Control panel display.
2. The glowing red LED light indicates an alarm situation or a fault. The blinking red light indicates a need to replace the filter.
3. Temperature sensor.
4. Up button is used to select a menu item by moving upwards or to increase a current parameter.
5. Down button is used to select a menu item by moving downwards or to decrease a current parameter.
6. Enter button is used to select a parameter to be edited or to move one level down in a list (in the main window it means menu access).
7. Escape button is used to move to a higher level up (in the main window it means interface language editing).
8. Power button is used to operate the unit status (turned on/off).
9. The green LED light indicates an operation status of the unit. The indicator glows when the unit is turned on, blinks during the heater shutdown mode and is off when the unit is off.

Fig. 11. Control panel mounting

Table 5. Unit parameters control and adjustment









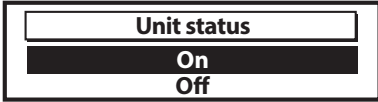
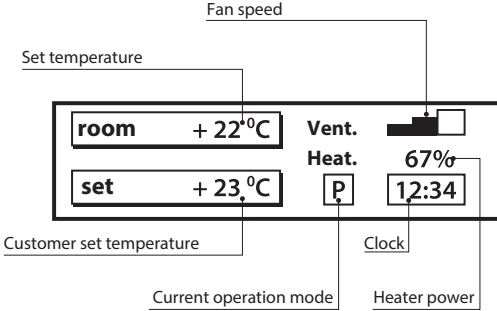

Function	Button / Button combination		Indication
To turn the unit on turn the power switch into «1» position. The display shows BLAUBERG logo and the LED light indicators do not glow. For power cut-off turn the power switch into «0» position.			
1 Unit activation			
Wall-mounted control panel:	press 	select On	press 
			 <p>The green LED light starts glowing.</p>
The current operation mode is activated and the control panel display shows the main window.			
			
Unit operation modes:			
<input type="checkbox"/> Manual mode (parameters are set by the user, the day and the week timers are off) – P .			
<input type="checkbox"/> Day timer – C .			
<input type="checkbox"/> Week time – H .			
2 Unit deactivation			
Wall-mounted control panel:	press 	select Off	press 
			 <p>The unit changes into the heater shutdown mode confirmed by the blinking green LED light indicator and turns off in 2 minutes. The parameters are selected and edited via the user menu (see below).</p>
Unit shutdown procedure:			
<input type="checkbox"/> shutdown of electric heating elements;			
<input type="checkbox"/> changeover to low speed and running with low speed for 2 minutes;			
<input type="checkbox"/> activation of Heater blowing mode. The green LED light is blinking.			
This mode is used for cooling of the electric heating elements and preventing tripping of the thermal switches.			
<input type="checkbox"/> unit shutdown in 2 minutes.			
3 Interface language selection			
Available interface language options: English; German (Deutsch); Russian (Русский); Ukrainian (Українська); Danish; Polish (Polski).			
Change of interface language as follows:	press 	select required language  	press 
			
Warning! If no button is pressed for 10 s or in case of pressing Escape button the system changes into main window without any changes.			

Table 5. Unit parameters control and adjustment (continued)

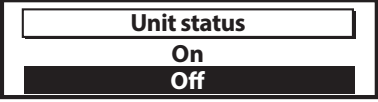





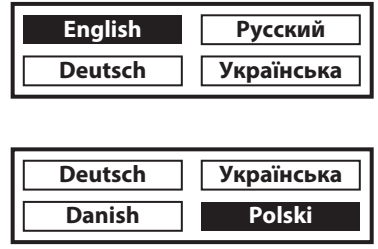





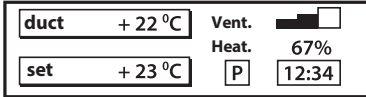
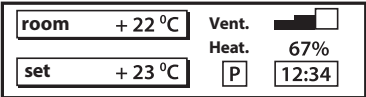







Function	Button / Button combination			Indication
4 Operation mode programming				
The unit has two temperature control modes: <input type="checkbox"/> room - indoor temperature control on feedback from the temperature sensor integrated into the control panel; <input type="checkbox"/> duct - air duct temperature control based on the duct temperature sensor.				
Changeover to selecting temperature control mode in the main window:	press 	or	press 	Set temperature is displayed: duct  room 
5 Menu				
The user menu consists of two levels, the Main menu and Service menu.				
Entering menu from the main window:	press 			
Navigation between the menu items use the buttons:	press 	or	press 	-
Back one level and entering the main window:	press 			-
Entering the current menu item for editing:	press 			-
5.1 Main menu				
Is used to edit the most important operating parameters:				
5.1.1 Temperature setting				
Entering the Temperature setting menu item:	select the required item  	press 		
Changing the set temperature:	set the required value  			
5.1.2 Setting fan speed				
Entering the Speed stage menu item:	select the required item  	press 		
Editing fan speed:	select the required item  			

Table 5. Unit parameters control and adjustment (continued)

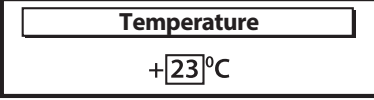





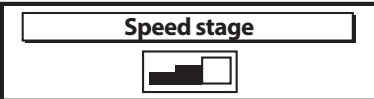









Function	Button / Button combination	Indication
5.2 Service menu		
Π Enables activation and adjustment of the service functions.		
5.2.1 Setting clock and calendar		
This function enables current date and time setting for correct operation of the day and week-scheduled operation. The clock has a non-volatile storage (battery) that saves the time settings even in case of no power supply. The battery is rated for 2-3 years operation. To replace the battery unlatch and open the control panel case.		
Entering the Service menu:	select the required item 	press 
		
Entering the Clock and Calendar menu item:	select the required item 	press 
		
Change the parameter to be edited (Year, Month, Year, Day, Hour, Minutes):		
Edit the selected item value:	set the required value 	
		
5.2.2 Setting the filter replacement timer		
Enables setting the filter replacement periodicity and activation of the warning signal from the control panel. The factory setting is 99 days.		
Entering the Service menu:	select the required item 	press 
		
Entering the Filter replacement timer menu item:	select the required item 	press 
		
Edit the selected item value:	select the required item 	
		
<p>Upon expiry of the set filter replacement periodicity the message "Replace filter" is displayed. The warning message is shown for a while instead of the main window and the red LED light blinks. To deactivate the warning message enter the Filter replacement timer menu and press the Enter button. The next warning signal appears in set time period. During the warning signal the unit operates normally.</p> <p>WARNING! To replace the filter disconnect the unit from power supply first and then replace the filter and turn the unit on.</p>		
5.2.3 Setting day timer		
Enables setting the unit activation and deactivation time. In case of activation of the mode the unit turns on and off in set time every day.		
Main window with activated day timer:	—	

Table 5. Unit parameters control and adjustment (continued)







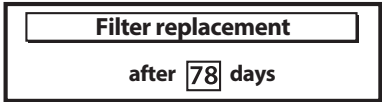
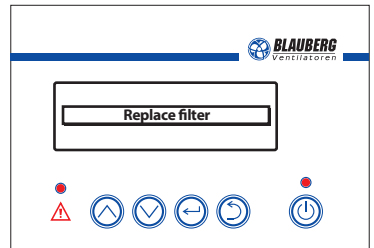
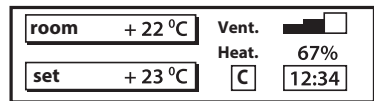















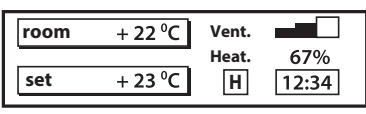

Function	Button / Button combination		Indication
Entering the Service menu:	select the required item 	press 	
Entering the Day timer menu item:	select the required item 	press 	
Select On :	select the required item 	press 	
Select the parameter to be edited (Year, Month, Date, Day, Hour, Minutes).			
Editing of the selected parameter. Day timer factory settings: <input type="checkbox"/> Turning ON time - 06:30; <input type="checkbox"/> Turning OFF time - 23:30.	select the required item 		
5.2.4 Setting week timer			
Enables programming of the week operation schedule. If this mode is activated the unit turns on in set time, operates in compliance with set parameters with automatic fan speed and temperature control according to set parameters of week schedule.			
Main window with activated week timer is displayed as follows:			
Entering the Service menu:	select the required item 	press 	
Entering the Week timer menu item:	select the required item 	press 	
Select On	select the required item 	press 	
Select the parameter to be edited (day of the week, operation duration, temperature control, fan speed stage)			
Parameter editing:	select the required item 		
WARNING! The day timer has higher priority. If the day timer is activated in the Current operating mode of the main window the light indicator  glows no matter of the week timer status.			

Table 5. Unit parameters control and adjustment (continued)

Function		Button / Button combination				Indication			
Week timer factory settings are as follows:									
Week day	Status	Period 1				Period 2			
		Turning ON time	Turning OFF time	Temperature [°C]	Speed stage	Turning ON time	Turning OFF time	Temperature [°C]	Speed stage
MO	ON	8:00	18:00	23		18:00	8:00	20	
TU	ON	8:00	18:00	23		18:00	8:00	20	
WD	ON	8:00	18:00	23		18:00	8:00	20	
TH	ON	8:00	18:00	23		18:00	8:00	20	
FR	ON	8:00	18:00	23		18:00	8:00	20	
ST	ON	8:00	18:00	23		18:00	8:00	20	
SU	ON	8:00	18:00	23		18:00	8:00	20	

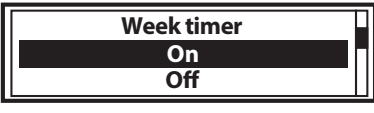
TROUBLESHOOTING AND FAULT HANDLING

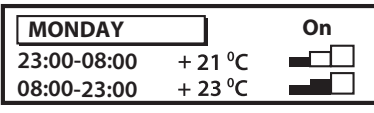
In case of tripping of any of the two overheat protection thermal switches, filter clogging indicated by tripping of the differential pressure sensor, in case of the communication circuit damage the unit changes into the emergency shutdown mode with Heater blowing mode activation and turns off in 2 minutes. The red LED light indicator turns on and the control panel displays the alarm message and its troubleshooting (ref. Table 6).

Table 6. Unit alarm indication

ALARM		Indication
Tripping of any of the two overheat protection thermal switches.	The unit changes into the emergency shutdown of the Heater cooling mode and turns off in 2 minutes. The red LED light indicator turns on and the control panel displays the alarm message and its troubleshooting.	FAULT!!! Heater overheating Unit OFF
Filter clogging (differential pressure sensor tripping).		FAULT!!! Filter clogging Unit OFF
Communication circuit damage.		FAULT!!! No communication Unit OFF

Table 7. Alarm list and troubleshooting

Fault	Possible reason	Troubleshooting
The fan does not start when the unit is on.	No power supply or wrong connection to power mains.	Connect the unit to power mains. Troubleshoot the connection error.
	Jammed motor, soiled impeller blades.	Remove the motor jam, clean the impeller blades.
Automatic switch tripping.	Short circuit in power grid.	Turn the unit off and contact the unit seller for troubleshooting.
Low air flow.	Too low set speed.	Set higher speed.
	The filter and the fans are soiled.	Clean or replace the filter, clean the fan.
	The air dampers, the supply diffusers or the exhaust grilles are closed or soiled.	Open and clean the air dampers, the supply diffusers and the grilles to ensure free air flow.
Low supply air temperature.	The supply filter is soiled.	Clean or replace the supply filter.
Noise, vibration.	The impeller is soiled.	Clean the impeller.
	The screw connection is loose.	Tighten the screws.
	No flexible anti-vibration connectors.	Install the flexible anti-vibration connectors.

TECHNICAL MAINTENANCE

WARNING

*Cut power supply to the unit off by turning the automatic electric switch QF to OFF position prior to any operations.
Take steps to prevent activation of the automatic switch before finishing all the operations.*

Regular technical supervision and maintenance of the unit are required to ensure the product long service life and non-stop operation.

Disconnect the unit from power mains prior to any maintenance operations.

Warning! Consider the unit sharp edges! Fulfill maintenance operations in work gloves!

The recommended unit maintenance periodicity is 3-4 times per year.

The unit technical maintenance includes regular cleaning and other works:

1. Filter maintenance (3-4 times a year)

A dirty filter increases air resistance and decreases supply air. Clean the filter with a vacuum cleaner or flush it with water. Install a dry filter only! Contact a local distributor for the filters stated above in the section «Technical data».

A contaminated filter is not considered as a warranty case!

Replace a humid and mouldy filter immediately!

2. Fan maintenance (once a year).

The regular filter cleaning may not completely prevent the dust ingress into the unit, which results in the unit capacity decrease. Clean the fan with a soft cloth or a brush. Cleaning with water, abrasive detergents, sharp object or chemicals is not allowed.

3. Supply air flow control (twice a year).

Check the supply grille and intake diffuser and remove foreign objects to maintain free air intake. Remove the supply grille and the intake diffuser and flush those with warm detergent solution. Check the ductworks thread connections periodically!

4. Air ducts maintenance (once in 5 years).

The regular unit maintenance in compliance with the above rules may not completely prevent dust ingress into the air ducts which may result in air flow decrease. The air duct maintenance consists in periodical cleaning or replacement.

ACCEPTANCE CERTIFICATE

The supply ventilation unit

BLAUBOX E200-1.8	
BLAUBOX E300-2.4	
BLAUBOX E400-2.4	
BLAUBOX E400-3.4	

BLAUBOX E400-5.1	
BLAUBOX E400-6	
BLAUBOX E800-3.4	
BLAUBOX E800-5.1	

BLAUBOX E800-6	
BLAUBOX E1000-3.6	
BLAUBOX E1000-6	
BLAUBOX E1000-9	

BLAUBOX E1200-6	
BLAUBOX E1200-9	
BLAUBOX E1500-6	
BLAUBOX E1500-9	

is recognized as serviceable.

The unit complies with the requirements according to the EU norms and directives, to the relevant EU-Low Voltage Equipment Directives, EU-Directives on Electromagnetic Compatibility. We hereby declare that the following product complies with the essential protection requirements of Electromagnetic Council Directive 2004/108/EC, 89/336/EEC and Low Voltage Directive 2006/95/EC, 73/23/EEC and CE-marking Directive 93/68/EEC on the approximation of the laws of the Member States relating to electromagnetic compatibility.

This certificate is issued following test carried out on samples of the product referred to above.

Approval mark

Manufacturing date _____

CONNECTION CERTIFICATE

The supply ventilation unit

BLAUBOX E200-1.8	
BLAUBOX E300-2.4	
BLAUBOX E400-2.4	
BLAUBOX E400-3.4	

BLAUBOX E400-5.1	
BLAUBOX E400-6	
BLAUBOX E800-3.4	
BLAUBOX E800-5.1	

BLAUBOX E800-6	
BLAUBOX E1000-3.6	
BLAUBOX E1000-6	
BLAUBOX E1000-9	

BLAUBOX E1200-6	
BLAUBOX E1200-9	
BLAUBOX E1500-6	
BLAUBOX E1500-9	

is connected to power mains in compliance with the operation manual requirements by the professional:

Company: _____

Name _____

Date _____ Signature _____

WARRANTY CARD

BLAUBOX E200-1.8	
BLAUBOX E300-2.4	
BLAUBOX E400-2.4	
BLAUBOX E400-3.4	

BLAUBOX E400-5.1	
BLAUBOX E400-6	
BLAUBOX E800-3.4	
BLAUBOX E800-5.1	

BLAUBOX E800-6	
BLAUBOX E1000-3.6	
BLAUBOX E1000-6	
BLAUBOX E1000-9	

BLAUBOX E1200-6	
BLAUBOX E1200-9	
BLAUBOX E1500-6	
BLAUBOX E1500-9	

SELLER

SALES DATE

REPRESENTATIVE IN EU

BLAUBERG Ventilatoren GmbH
Aidenbachstr. 52a,
D-81379 München,
Deutschland



BLAUBERG
Ventilatoren



www.blaubergventilatoren.de
BLAUBOX E v.2(2) / 10-2014 / EN

