

# BSK1

## Fire-resisting dampers

### Use

- The fire-resisting dampers are intended for automatic closing of process openings and air duct penetrations in intermediate floors, walls and partitions, as well as closing of openings in supply and exhaust ducts of smoke ventilation systems.
- The dampers of this particular design are not suitable for installation in air ducts and ducts of premises with rated explosion and fire safety category A and B and in flammable and explosive mixture intakes.
- The **BSK1** fire-resisting duct dampers are capable of resisting fire for at least 60 minutes (EI 60) at the temperature of 600 °C.

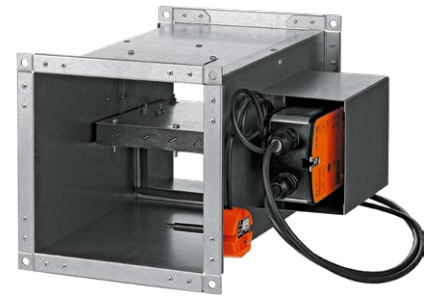

**BSK1...PKP  
BSK1...PVP  
BSK1...PSP**  
normally open fire-resisting duct damper with electric drive mechanism.



**BSK1...72S**  
normally open fire-resisting duct damper with mechanical drive mechanism.

### Design

- The **BSK1** series dampers are made in the general-purpose industrial version with a minimized variety of hardware components using low-alloy galvanized steel. The damper flap is made of fire-resistant material.
- The duct installation design results in two mounting flanges on the casing for integration into a ventilation duct (air ducting) and external configuration of the drive mechanism for easier maintenance.
- The **BSK1** series dampers are characterised by a simplified design and the absence of a hot and cold zone baffle.

### Control and modifications

- Depending on the design variant BSK1 series dampers are equipped with:

#### MECHANICAL ACTUATING UNIT WITH A THERMAL FUSE AND A RETURN SPRING

- The damper is set to the operating position upon the thermal fuse breakdown resulting from a temperature increase.
- Emergency damper actuation: the flap remains in protective position (damper unaffected by fire) and is fixed by a thermal fuse (when the flap is installed in security position, a reverse spring is activated). Upon emergency actuation (damper directly affected by fire) the thermal fuse breaks down and the return spring moves the flap to operating position.

#### ELECTRIC ACTUATOR WITH A BUILT-IN RETURN SPRING AND A BACK-UP THERMAL BREAKER

- Setting the damper to operating position (direct fire contact): remotely, via an electric actuator. The damper can be set to the operating or protective position either remotely via a control panel or manually using a manual cocking handle which is always included in the standard delivery set of the electric actuator. In case of the remote control panel failure, the back-up thermal breaker interrupts the power supply to the electric actuator and the return spring sets the damper to the operating position.
- Emergency damper actuation: the damper flap is set to the protective position automatically (damper unaffected by fire). The electric actuator remains energized at all times.
- In case of an emergency actuation (direct fire contact), the electric actuator equipped with a return spring is de-energized and the damper flap is set to the operating position by means of the spring energy. In case of a power failure not related to fire and its subsequent restoration at the actuator with a return spring, the damper flap returns to protective position.

**Designation key**

**BSK 1 20 x30 / 2 PVP24T / O**

**Series:**  
Fire-resisting damper

**Fire resistance rating:**  
1: 1 hour

**Damper flow area width [cm]:**  
20; 25; 30; 40; 50; 60; 80; 100

**Damper flow area height [cm]:**  
20; 25; 30; 40; 50; 60; 80; 100

**Number of flanges:**  
1: one  
2: two

**Actuator type:**  
72S: thermal fuse and return spring (manual actuation)  
PKP24T: 24 V ZERN electric actuator with a return spring and a thermal breaker  
PVP24T: 24 V BELIMO electric actuator with a return spring and a thermal breaker  
PSP230T: 230 V BELIMO electric actuator with a return spring and a thermal breaker  
PSP24T: 24 V SIEMENS electric actuator with a return spring and a thermal breaker  
PSP230T: 230 V SIEMENS electric actuator with a return spring and a thermal breaker

**Actuator location:**  
O: outside  
I: inside (except for dampers with height or width less than 30 cm)

**BSK1...72S FIRE SAFETY DAMPER WITH A MECHANICAL ACTUATING UNIT WITH A THERMAL FUSE AND A RETURN SPRING**

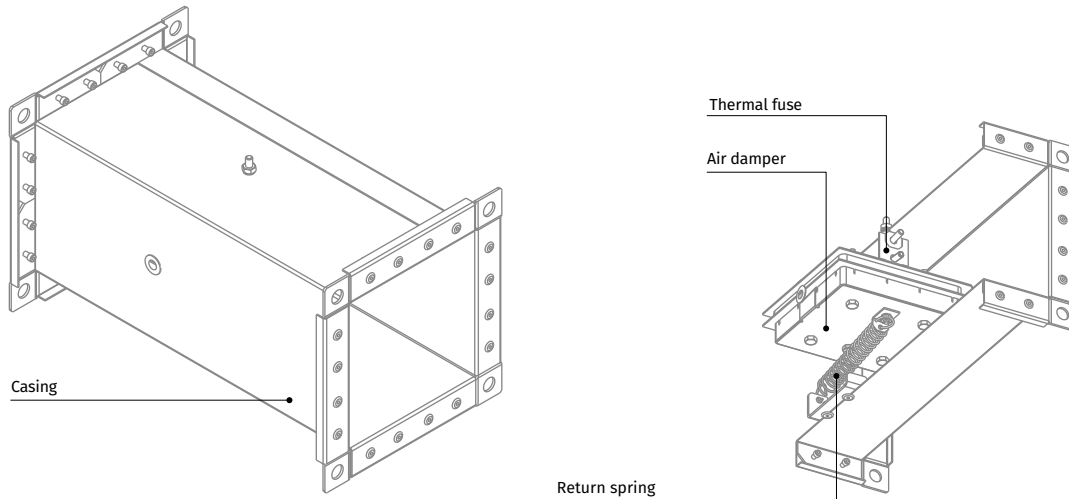

**BSK1...PKP/BSK1...PVP/BSK1...PSP FIRE SAFETY DAMPER WITH A BELIMO ELECTRIC ACTUATOR AND A THERMOELECTRIC BREAKER**

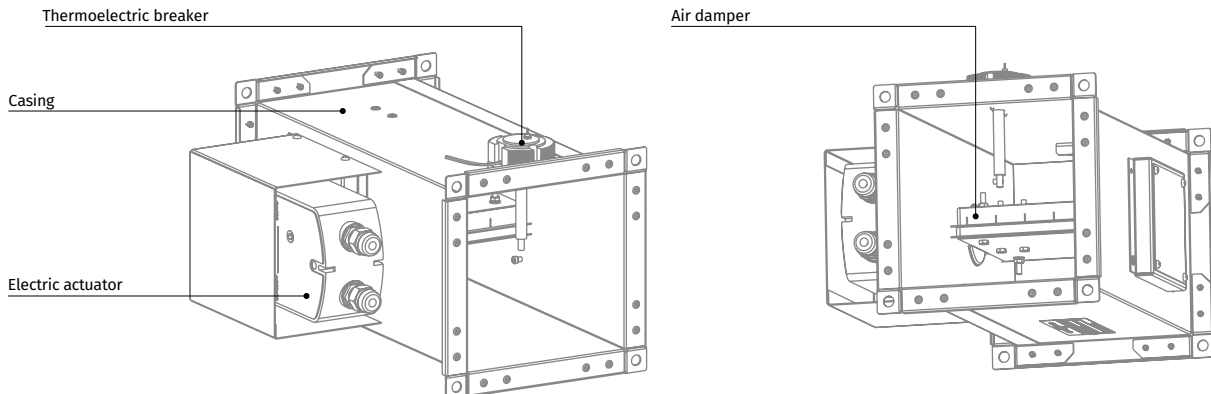

## Mounting

- The damper must be installed into the building envelope structure in accordance with the applicable standards and regulations. The seal fire resistance must be at least equal to that of the building envelope.
- The dampers can be installed in any position in vertical and horizontal ducts of fire-protection structures. The ducts for damper installation must be made in such a way so as to prevent the transfer of loads caused by the fire-protection structures to the damper casing. The adjoining air duct must be suspended in such a way so as to prevent the transfer of air duct load to the damper flange. The minimum free space for accessing the control parts must be at least 350 mm. Make sure to arrange an inspection hole. While carrying out the installation consider size K. When two or more dampers are installed into the same fire-protection separation structure, the distance between the two adjacent dampers must be at least 200 mm.
- The damper must be installed in such a way that the damper flap (in its closed position) lies in the fire-protection divider structure plane. If such installation is not possible, the damper casing part between the fire-protection separation structure and the damper flap must be insulated with a suitable material pursuant to the applicable standards.
- The damper control mechanism must be protected against damage and contamination. The damper casing must not deform any deformation during embedding. After the installation the flap must not catch against the damper casing while opening or closing. The fire safety damper can be integrated into a tight wall structure - e.g. made of conventional concrete work of minimum width  $W = 100$  mm or into a plasterboard wall of the necessary fire resistance class or into a tight ceiling structure - e.g. made of conventional concrete of minimum width  $W = 150$  mm. Do not use any foaming substances for sealing the damper in the separation structure.

### INSTALLATION RECOMMENDATIONS FOR BSK1...72S DAMPERS WITH THERMAL FUSE AND RETURN SPRING:

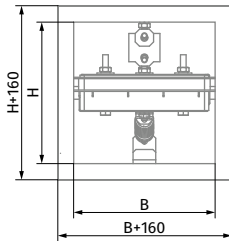

For Sizes B and H please refer to the dimension table

#### IN VERTICAL BUILDING STRUCTURES

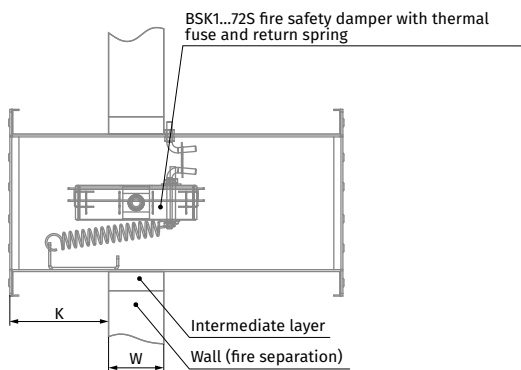

#### IN HORIZONTAL BUILDING STRUCTURES

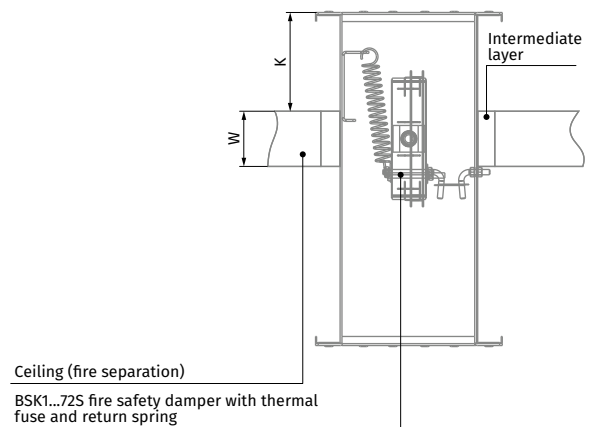

#### DUCT MODIFICATION WITH AN AIR DUCT

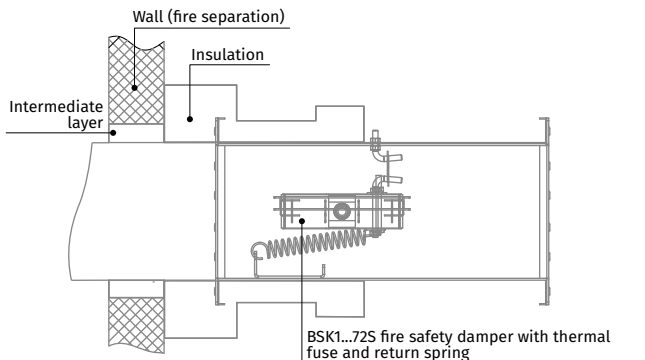

**INSTALLATION RECOMMENDATIONS FOR BSK1...PKP/BSK1...PVP/BSK1...PSP FIRE SAFETY DAMPERS WITH ELECTRIC ACTUATOR AND THERMOELECTRIC BREAKER**

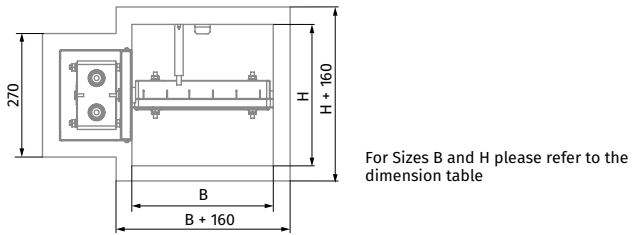

**IN VERTICAL BUILDING STRUCTURES**

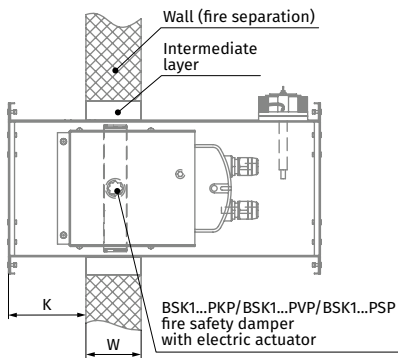

**IN HORIZONTAL BUILDING STRUCTURES**

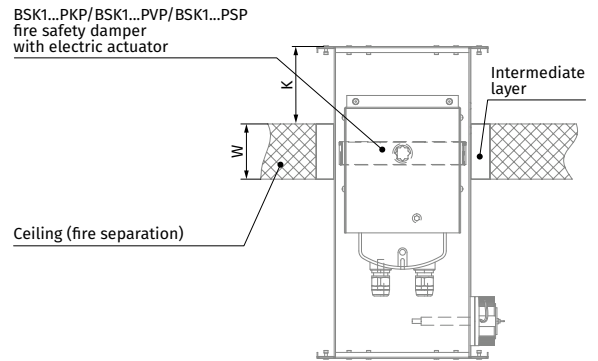

**DUCT MODIFICATION WITH AN AIR DUCT**

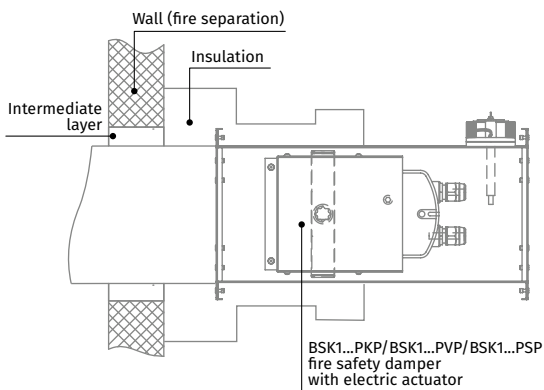

## Overall and connecting dimensions

### BSK1...72S DAMPERS WITH MECHANICAL ACTUATOR

Duct cross-section	Dimensions [mm]						Weight [kg]
	B	B1	B2	H	H1	H2	
BSK1 20x20/2 72S/O	200	220	240	200	220	240	3.5
BSK1 25x20/2 72S/O	250	270	290	200	220	240	4
BSK1 25x25/2 72S/O	250	270	290	250	270	290	4.5
BSK1 30x20/2 72S/O	300	320	340	200	220	240	4.5
BSK1 30x25/2 72S/O	300	320	340	250	270	290	5.1
BSK1 30x30/2 72S/O	300	320	340	300	320	340	5.8
BSK1 40x25/2 72S/O	400	420	440	250	270	290	6.3
BSK1 40x30/2 72S/O	400	420	440	300	320	340	7.1
BSK1 40x40/2 72S/O	400	420	440	400	420	440	8.7
BSK1 50x30/2 72S/O	500	520	540	300	320	340	8.5
BSK1 50x40/2 72S/O	500	520	540	400	420	440	10.3
BSK1 50x50/2 72S/O	500	520	540	500	520	540	12
BSK1 60x40/2 72S/O	600	620	640	400	420	440	11.9
BSK1 60x50/2 72S/O	600	620	640	500	520	540	13.8
BSK1 60x60/2 72S/O	600	620	640	600	620	640	16.1

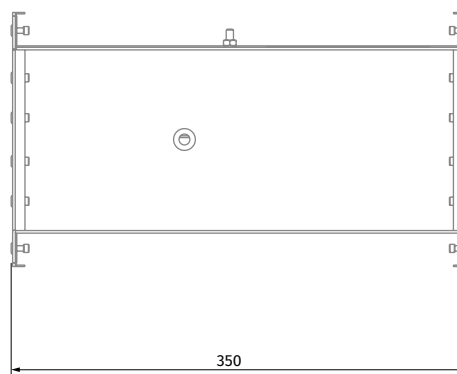
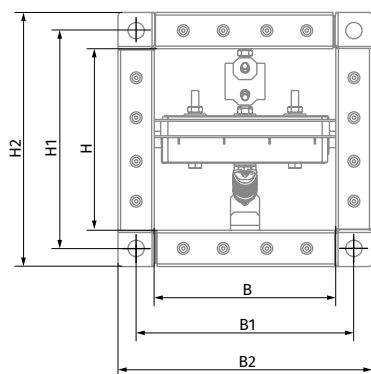

### FLOW AREA OF FIRE-RESISTING DUCT DAMPER WITH MECHANICAL ACTUATOR [m<sup>2</sup>]

B/H [mm]	200	250	300	400	500	600
200	0.032					
250	0.04	0.053				
300	0.048	0.063	0.078			
400	0.064	0.084	0.104	0.144		
500	0.08	0.105	0.13	0.18	0.23	
600	0.096	0.126	0.156	0.216	0.276	0.336

Dampers with dimensions not included in the table can be produced on request.  
Limit damper size: 600x600 mm

## Overall and connecting dimensions

### BSK1...PKP/BSK1...PVP/BSK1...PSP DAMPERS WITH ELECTRIC ACTUATORS

Duct cross-section	Dimensions [mm]							Weight [kg]
	B	B1	B2	B3	H	H1	H2	
BSK1 20x20/2 .../O	200	220	240	325	200	220	240	6.2
BSK1 25x20/2 .../O	250	270	290	375	200	220	240	6.8
BSK1 25x25/2 .../O	250	270	290	375	250	270	290	7.3
BSK1 30x20/2 .../O	300	320	340	425	200	220	240	7.3
BSK1 30x25/2 .../O	300	320	340	425	250	270	290	7.9
BSK1 30x30/2 .../O	300	320	340	425	300	320	340	8.5
BSK1 40x25/2 .../O	400	420	440	525	250	270	290	9.1
BSK1 40x30/2 .../O	400	420	440	525	300	320	340	9.8
BSK1 40x40/2 .../O	400	420	440	525	400	420	440	11.3
BSK1 50x30/2 .../O	500	520	540	625	300	320	340	10.7
BSK1 50x40/2 .../O	500	520	540	625	400	420	440	12.9
BSK1 50x50/2 .../O	500	530	560	635	500	530	560	16.6
BSK1 60x40/2 .../O	600	620	640	725	400	420	440	14.5
BSK1 60x50/2 .../O	600	630	660	735	500	530	560	18.4
BSK1 60x60/2 .../O	600	630	660	735	600	630	660	20.6
BSK1 80x50/2 .../O	800	830	860	935	500	530	560	22.3
BSK1 80x60/2 .../O	800	830	860	935	600	630	660	24.8
BSK1 80x80/2 .../O	800	830	860	935	800	830	860	30.1
BSK1 100x60/2 .../O	1000	1030	1060	1135	600	630	660	29
BSK1 100x80/2 .../O	1000	1030	1060	1135	800	830	860	35.4
BSK1 100x100/2 .../O	1000	1030	1060	1135	1000	1030	1060	41.7

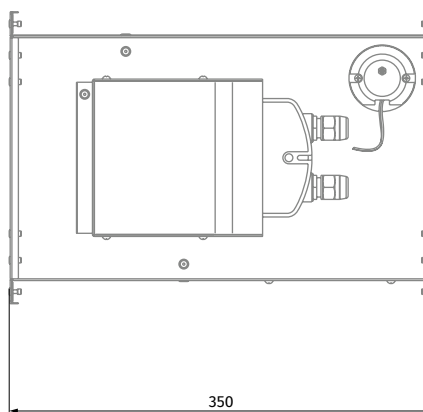
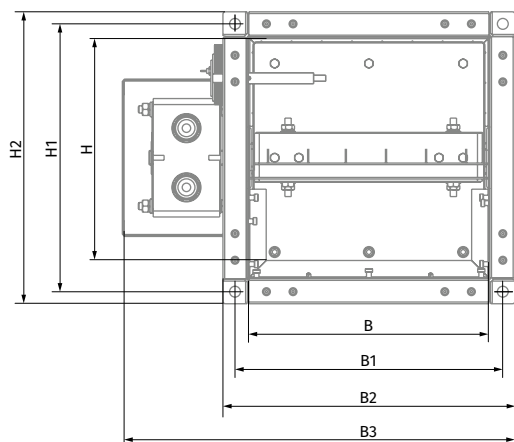

Note: The values given in the table for dampers with 230 V actuators are identical for those equipped with 24 V actuators.

FIRE SAFETY DAMPERS

### FLOW AREA OF THE DUCT FIRE-RESISTANT DAMPER WITH AN ELECTRIC ACTUATOR INSTALLED OUTSIDE THE DAMPER [m²]

B/H [mm]	200	250	300	400	500	600	800	1000
200	0.032							
250	0.04	0.053						
300	0.048	0.063	0.078					
400	0.064	0.084	0.104	0.144				
500	0.08	0.105	0.13	0.18	0.23			
600	0.096	0.126	0.156	0.216	0.276	0.336		
800	0.128	0.168	0.208	0.288	0.368	0.448	0.608	
1000	0.16	0.21	0.26	0.36	0.46	0.56	0.76	0.96

Dampers with dimensions not included in the table can be produced on request.  
Limit damper size: 1000x1000 mm

## Technical data

### BELIMO ELECTRIC ACTUATORS WITH A RETURN SPRING AND A THERMAL BREAKER

Parameters	Basic models		Models with increased torque		Models with the highest torque	
Rated voltage [V]	AC/DC 24	AC 230	AC/DC 24	AC 230	AC/DC 24	AC 230
Rated voltage range [V]	AC 19.2...28.8 DC 21.6...28.8	AC 198...264	AC 19.2...28.8 DC 21.6...28.8	AC 198...264	AC 19.2...28.8 DC 21.6...28.8	AC 198...264
Rated voltage frequency AC [Hz]	50/60		50/60		50/60	
Power consumption in rest position [W]	0.8	1.1	1.4	2.1	2	3
Power consumption in operation [W]	2.5	3.5	4	5	7	8.5
Maximum design capacity [VA]	4	6.5	6	10	10	11
Motor torque [Nm]	4		9		18	
Spring torque [Nm]	3		7		12	
Protection class	III	II	III	II	III	II
Ingress protection rating	IP54	IP54	IP54	IP54	IP54	IP54
Auxiliary switches	2 pcs., single-pole, reversible, 1 mA...3(0,5)A, AC 250 V				2 pcs., single-pole, reversible, 1 mA...6(3)A, AC 250 V	
Electric motor connection cable	1 m, 2 x 0.75 mm <sup>2</sup> (halogen-free)					
Auxiliary switch connection cable	1 m, 6 x 0.75 mm <sup>2</sup> (halogen-free)					
Running time spring	20 seconds at -10...+55 °C < 60 seconds at -30...-10 °C		20 seconds at -10...+55 °C < 60 seconds at -30...-10 °C		16 seconds at +20 °C	
Running time motor	< 60 s/90°		< 60 s/90°		< 120 s/90°	
Response temperature of thermal breaker sensors	Duct sensor 72 °C Outdoor sensor 72 °C					
Service life	Min. 60 000 emergency positions					
Technical maintenance	Not required					

### ZERN ELECTRIC ACTUATORS WITH A RETURN SPRING AND A THERMAL BREAKER

Parameters	Basic models		Models with increased torque	
Rated voltage [V]	AC/DC 24	AC 100–240	AC/DC 24	AC 100–240
Rated voltage range [V]	AC/DC 19.2...28.8	AC 85...265	AC/DC 19.2...28.8	AC 85...265
Rated voltage frequency AC [Hz]	50/60		50/60	
Power consumption in rest position [W]	3		3	
Power consumption in operation [W]	5		5	
Motor torque [Nm]	5		8	
Spring torque [Nm]	5		8	
Protection class	III	II	III	II
Ingress protection rating	IP54	IP54	IP54	IP54
Auxiliary switches	2 pcs., single-pole, reversible, 1 mA...3(0,5)A, AC 220 V			
Electric motor connection cable	1 m, 2 x 0.5 mm <sup>2</sup> (halogen-free)			
Auxiliary switch connection cable	1 m, 6 x 0.5 mm <sup>2</sup> (halogen-free)			
Running time spring	<20 seconds < 60 seconds at -30...-10 °C		<25 seconds < 60 seconds at -30...-10 °C	
Running time motor	< 70 s/95°		< 100 s/95°	
Response temperature of thermal breaker sensors	Duct sensor 72 °C Outdoor sensor 72 °C			

**SIEMENS ELECTRIC ACTUATORS WITH A RETURN SPRING AND A THERMAL BREAKER**

Parameters	Basic models		Models with increased torque		Models with the highest torque	
Rated voltage [V]	AC 24/ DC 24...48	AC 230	AC 24/ DC 24...48	AC 230	AC 24/ DC 24...48	AC 230
Rated voltage range [V]	AC/DC ±20 %	AC ±15 %	AC/DC ±20 %	AC ±15 %	AC/DC ±20 %	AC ±15 %
Rated voltage frequency AC [Hz]	50/60		50/60		50/60	
Power consumption in rest position [W]	2	3.5	2	3.5	3	4
Power consumption in operation [W]	3.5	4.5	3.5	4.5	5	6
Maximum design capacity [VA]	5	7	5	7	7	8
Motor torque [Nm]	4		9		18	
Spring torque [Nm]	4		7		18	
Protection class	III	II	III	II	III	II
Ingress protection rating	IP54	IP54	IP54	IP54	IP54	IP54
Auxiliary switches	2 pcs., single-pole, reversible, 6(2)A, AC 24...250 V					
Electric motor connection cable	0.9 m, 2 x 0.75 mm <sup>2</sup> (halogen-free)					
Auxiliary switch connection cable	0.9 m, 6 x 0.75 mm <sup>2</sup> (halogen-free)					
Running time spring	15 seconds < 60 seconds at -30...-10 °C					
Running time motor	90 s/90°					
Response temperature of thermal breaker sensors	Duct sensor 72 °C Outdoor sensor 72 °C					
Service life	10 000 emergency positions					
Technical maintenance	Not required					

**Electrical connection**

**BASIC MODELS OF BELIMO AND ZERN ELECTRIC ACTUATORS. BELIMO AND ZERN MODELS WITH INCREASED TORQUE**

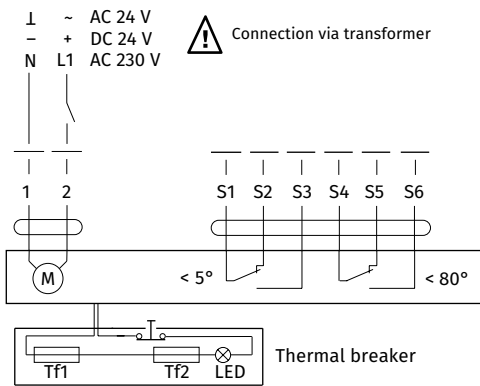

**BELIMO ELECTRIC ACTUATORS WITH THE HIGHEST TORQUE, SIEMENS ELECTRIC ACTUATORS**

