

BSK

Fire-resisting dampers

Use

- A fire safety damper prevents the spread of smoke and fire via ventilation and air conditioning system ducts in the event of fire.
- Such units are installed in air ducts located in fire-separation walls and ceilings. The fire resistance rating according to EN 1366-2 is EIS 60 or EIS 120.



Normally open fire-resisting duct damper with a thermal fuse and a return spring

Normally open fire-resisting duct damper with an electric actuator, a return spring and a thermoelectric breaker

Design

- The **BSK** series dampers are made in the general-purpose industrial version with a minimized variety of hardware components using low-alloy galvanized steel. The flap is made of fire-resistant material (vermiculite) with thermoexpansive fireproof sealing.
- The duct design implies two connection ports for integration into a ventilation duct (duct system).

Control and modifications

- Depending on the design variant the **BSK** series dampers are equipped with:

MECHANICAL ACTUATING UNIT WITH A THERMAL FUSE AND A RETURN SPRING

- The fire safety damper remains open in the protective position. The damper is set to the operating position upon the thermal fuse breakdown resulting from a temperature increase. In the event of fire, the fusible element will melt upon the temperature reaching 72 °C and the spring will set the flap to the closed position.

ELECTRIC ACTUATOR WITH A BUILT-IN RETURN SPRING AND A THERMALLY SENSITIVE BREAKER

- Setting the damper to operating position (direct fire contact): remotely, via electric actuator. The damper can be set to the operating or protective position either remotely via a control panel or manually using the manual cocking handle which is always included in the standard delivery set of the electric actuator. In case of the remote control panel failure, the back-up thermal breaker interrupts the power supply to the electric actuator and the return spring sets the damper to the operating position. Emergency damper actuation: The damper flap is set to the protective position automatically (damper unaffected by fire). The electric actuator remains energized at all times. In case of an emergency actuation (direct fire contact): The electric actuator equipped with a return spring is de-energized and the damper flap is set to the operating position by means of the spring energy. In case of a power failure not related to fire and its subsequent restoration at the actuator with a return spring, the damper flap returns to a protective position.

Mounting

- During the fire safety damper installation make sure that the release mechanism and the inspection hole face an easily accessible side of the wall or ceiling. This will ensure convenient control of the thermally sensitive release mechanism and its internals.
- The damper can be embedded into brick or concrete walls with the appropriate fire resistance rating.
- Wooden spreader bars should be used to avoid casing deformation during the installation.

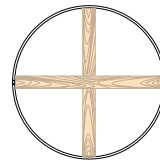

Use of wooden spreader bars during installation

- Upon completing the installation remove the wooden spreader bars.

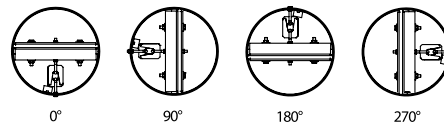

Recommended damper positions

- The damper may not be installed:
 - Into air ducts and on premises rated explosion and fire safety category A and B.
 - Into air ducts of local intakes for flammable and explosive mixtures.
 - Into systems which are do not undergo periodic cleaning pursuant to the established regulations for prevention of flammable deposit buildup.

Designation key

BSK 1 100 PVP24T

Series:
Fire-resisting damper

Fire resistance:
1: 1 hour
2: 2 hours

Rated damper diameter [mm]:
100; 125; 150; 160; 180; 200; 225; 250; 315; 355; 400

Actuator type:
1A: thermal fuse and return spring (manual actuation)
PKP24T: 24 V ZERN electric actuator with a return spring and a thermal breaker
PKP230T: 230 V ZERN electric actuator with a return spring and a thermal breaker
PVP24T: 24 V BELIMO electric actuator with a return spring and a thermal breaker
PVP230T: 230 V BELIMO electric actuator with a return spring and a thermal breaker
PSP24T: 24 V SIEMENS electric actuator with a return spring and a thermal breaker
PSP230T: 230 V SIEMENS actuator with a return spring and a thermal breaker

THE BSK...1A FIRE SAFETY DAMPER WITH A MECHANICAL ACTUATING UNIT, A THERMAL FUSE AND A RETURN SPRING

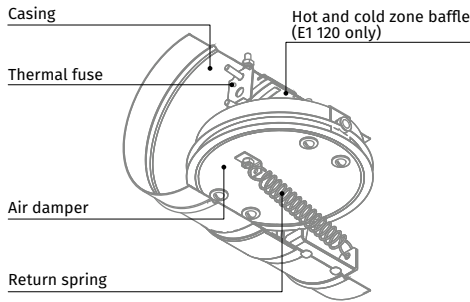

THE BSK...PKP/BSK...PVP/BSK...PSP FIRE SAFETY DAMPER WITH AN ELECTRIC ACTUATOR AND A THERMOELECTRIC BREAKER

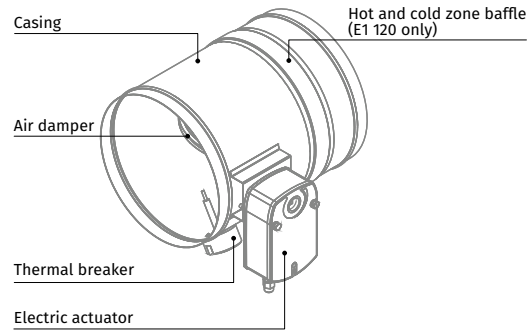

INSTALLATION RECOMMENDATIONS FOR BSK...1A DAMPERS WITH A MECHANICAL ACTUATING UNIT WITH A THERMAL FUSE AND A RETURN SPRING

IN VERTICAL BUILDING STRUCTURES

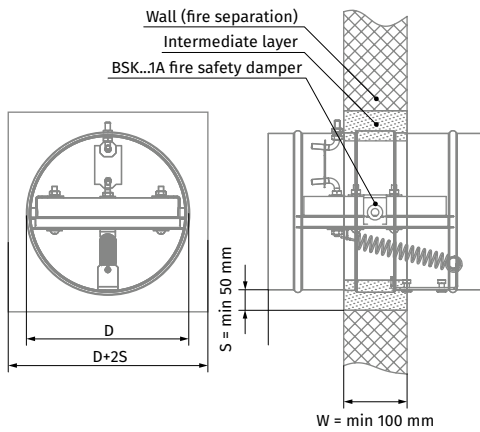

IN HORIZONTAL BUILDING STRUCTURES

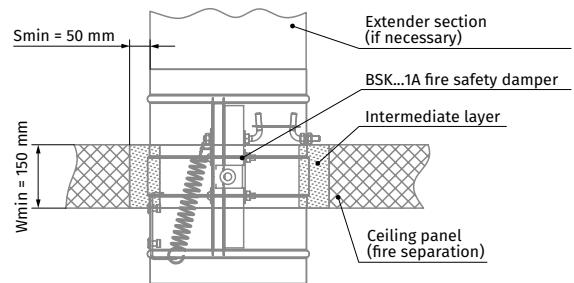

INSTALLATION RECOMMENDATIONS FOR BSK...PKP/BSK...PVP/BSK...PSP FIRE SAFETY DAMPERS WITH ELECTRIC ACTUATOR AND THERMOELECTRIC BREAKER

IN VERTICAL BUILDING STRUCTURES

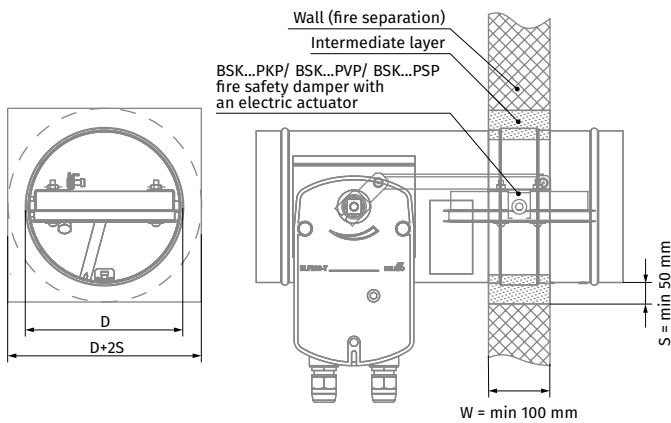

IN HORIZONTAL BUILDING STRUCTURES

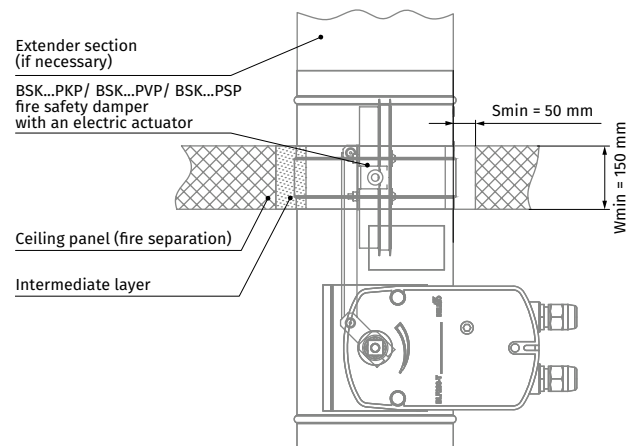

FIRE SAFETY DAMPER WITH A MECHANICAL ACTUATING UNIT, A THERMAL FUSE AND A RETURN SPRING

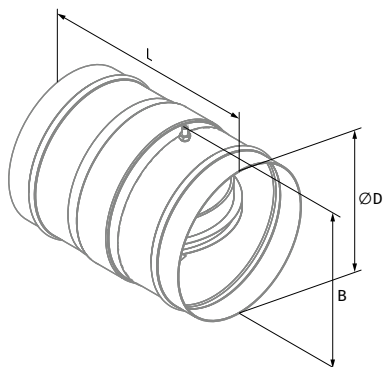

FIRE SAFETY DAMPER WITH AN ELECTRIC ACTUATOR AND A THERMALLY SENSITIVE BREAKER

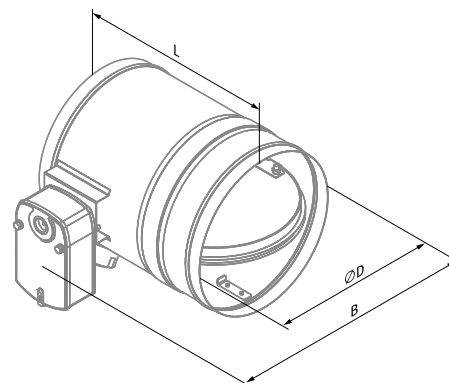

Overall and connecting dimensions

BSK DAMPERS WITH A MECHANICAL ACTUATOR

Modification	Dimensions [mm]			Weight [kg]
	Ø D	L	B	
BSK...100 1A	99	170	112	1
BSK...125 1A	124	170	137	1.2
BSK...150 1A	149	170	162	1.5
BSK...160 1A	159	170	172	1.6
BSK...180 1A	179	170	192	1.8
BSK...200 1A	199	170	212	2
BSK...225 1A	224	170	237	2.2
BSK...250 1A	249	190	262	2.5
BSK...315 1A	314	190	327	3.6
BSK...355 1A	354	190	367	4.4
BSK...400 1A	399	240	412	6

BSK DAMPERS WITH AN ELECTRIC ACTUATOR

Modification	Dimensions [mm]			Weight [kg]
	Ø D	L	B	
BSK...100 PKP(PVP, PSP)	99	300	195	2.9
BSK...125 PKP(PVP, PSP)	124	300	215	3.1
BSK...150 PKP(PVP, PSP)	149	300	245	3.4
BSK...160 PKP(PVP, PSP)	159	300	255	3.5
BSK...180 PKP(PVP, PSP)	179	300	275	3.8
BSK...200 PKP(PVP, PSP)	199	300	295	4
BSK...225 PKP(PVP, PSP)	224	300	325	4.4
BSK...250 PKP(PVP, PSP)	249	310	345	4.7
BSK...315 PKP(PVP, PSP)	314	310	415	6.5
BSK...355 PKP(PVP, PSP)	354	310	455	8.3
BSK...400 PKP(PVP, PSP)	399	310	505	9.9

Technical data

BELIMO ELECTRIC ACTUATORS WITH A RETURN SPRING AND A THERMAL BREAKER

Parameters	Basic models	
Rated voltage [V]	AC/DC 24	AC 230
Rated voltage range [V]	AC 19.2...28.8 DC 21.6...28.8	AC 198...264
Rated voltage frequency AC [Hz]	50/60	
Power consumption in rest position [W]	0.8	1.1
Power consumption in operation [W]	2.5	3.5
Maximum design capacity [VA]	4	6.5
Motor torque [Nm]	4	
Spring torque [Nm]	3	
Protection class	III	II
Ingress protection rating	IP54	IP54
Auxiliary switches	2 pcs., single-pole, reversible, 1 mA...3(0,5)A, AC 250 V	
Electric motor connection cable	1 m, 2 x 0.75 mm ² (halogen-free)	
Auxiliary switch connection cable	1 m, 6 x 0.75 mm ² (halogen-free)	
Running time spring	20 seconds at -10...+55 °C < 60 seconds at -30...-10 °C	
Running time motor	< 60 s/90°	
Response temperature of thermal breaker sensors	Duct sensor 72 °C Outdoor sensor 72 °C	
Service life	Min. 60 000 emergency positions	
Technical maintenance	Not required	

ZERN ELECTRIC ACTUATORS WITH A RETURN SPRING AND A THERMAL BREAKER

Parameters	Basic models	
Rated voltage [V]	AC/DC 24	AC 100-240
Rated voltage range [V]	AC/DC 19.2...28.8	AC 85...265
Rated voltage frequency AC [Hz]	50/60	
Power consumption in rest position [W]	3	
Power consumption in operation [W]	5	
Motor torque [Nm]	5	
Spring torque [Nm]	5	
Protection class	III	II
Ingress protection rating	IP54	IP54
Auxiliary switches	2 pcs., single-pole, reversible, 1 mA...3(0,5)A, AC 220 V	
Electric motor connection cable	1 m, 2 x 0.5 mm ² (halogen-free)	
Auxiliary switch connection cable	1 m, 6 x 0.5 mm ² (halogen-free)	
Running time spring	<20 seconds < 60 seconds at -30...-10 °C	
Running time motor	< 70 s/95°	
Response temperature of thermal breaker sensors	Duct sensor 72 °C Outdoor sensor 72 °C	

SIEMENS ELECTRIC ACTUATORS WITH A RETURN SPRING AND A THERMAL BREAKER

Parameters	Basic models	
Rated voltage [V]	AC 24/DC 24...48	AC 230
Rated voltage range [V]	AC/DC ±20 %	AC ±15 %
Rated voltage frequency AC [Hz]	50/60	
Power consumption in rest position [W]	2	3.5
Power consumption in operation [W]	3.5	4.5
Maximum design capacity [VA]	5	7
Motor torque [Nm]	4	
Spring torque [Nm]	4	
Protection class	III	II
Ingress protection rating	IP54	IP54
Auxiliary switches	2 pcs., single-pole, reversible, 6(2)A, AC 24...250 V	
Electric motor connection cable	0.9 m, 2 x 0.75 mm ² (halogen-free)	
Auxiliary switch connection cable	0.9 m, 6 x 0.75 mm ² (halogen-free)	
Running time spring	15 seconds < 60 seconds at -30...-10 °C	
Running time motor	90 s/90°	
Response temperature of thermal breaker sensors	Duct sensor 72 °C Outdoor sensor 72 °C	
Service life	10 000 emergency positions	
Technical maintenance	Not required	