



Speed controller

CDT(E) E

OPERATION MANUAL



EN



BLAUBERG
Ventilatoren

CONTENTS

Introduction	p. 3
Safety requirements	p. 3
Operating requirements	p. 4
Mounting	p. 4
Maintenance	p. 4
Transportation and storage	p. 4
Use	p. 5
Delivery Set	p. 5
Designation key	p. 5
Main technical data	p. 5
Description and design	p. 6
Connection to power mains	p. 7
Minimum speed setting	p. 7
Typical faults and fault handling	p. 8
Wall surface mounting procedure	p. 9
Wall flush mounting procedure	p. 10
Manufacturer's warranty	p. 11
Warranty card	p. 15
Acceptance certificate	p. 16

The present operation manual consisting of the technical details, operating instructions and technical specification applies to the control unit enclosed in a versatile casing (CDT(E) E) and covers its installation as well as the regulations and warnings required for correct and safe operation of the product.

INTRODUCTION

Disconnect the product from the power mains prior to all operations specific to connection, setup, maintenance and repair. The power mains connection must be performed by qualified personnel with valid permit for unassisted operations with electrical installations up to 1000 V after careful reading of the present operation manual. The single-phase mains which the product is to be connected to shall be compliant with the standing regulations. The stationary wiring shall be equipped with an automatic circuit breaker.

Connect the product to power mains through QF circuit breaker integrated into the stationary wiring with the contact gap on all poles at least 3 mm. Prior to connecting the unit to the power mains check it for visible damage as well as for any foreign objects in the unit casing.

SAFETY REQUIREMENTS

RESTRICTIONS:

- The controller may only be used as intended. No modifications or alterations are allowed;
- Do not use the controller if the ambient air contains explosive or corrosive substances;
- Avoid moisture and splashes on the controller casing;
- Do not block the vents in the casing;
- Do not position the controller close to heating appliances.

The product is not to be used by children and persons with reduced physical, mental or sensory capacities, without proper practical experience or expertise, unless they are controlled or instructed on the product operation by the person(s) responsible for their safety.

Do not leave children unattended and do not let them play with the product.

Do not sit on the product and do not put objects on it.

Fulfil the requirements stated in this user's manual to ensure long service life of the product.

OPERATION REQUIREMENTS

The product is rated for connection to single-phase AC 220–240 V, 50 Hz power mains. Ingress protection rating against access to hazardous parts and water ingress IP30. The product is rated for operation at the ambient temperature ranging from +1 °C up to +45 °C. The product is classified as Class II electric appliance.

MOUNTING

Both wall surface and flush mounting options are possible depending on the controller type. The controller is mounted using the screws and dowels included in the delivery set. The wall surface mounting sequence is shown in Fig. A-F. The wall flush mounting sequence is shown in Fig. G-M.

MAINTENANCE

Clean the product from any dust and dirt which may accumulate on the surfaces. Power off the product before performing any maintenance operations. For cleaning use a soft cloth and a brush soaked in an water detergent solution. Avoid any liquid on the electrical components. Wipe the cleaned surfaces dry.

TRANSPORTATION AND STORAGE

Transportation of the product with any vehicle is allowed. The unit must be stored in the original packing at ambient air temperatures from +5 °C to +40 °C at relative air humidity not more than 80 %. The storage environment must be free from dust and corrosive acid or alkaline vapours.



Recycle at the end of the service life.

Do not dispose the product with unsorted municipal trash.

USE

CDT(E) E thyristor speed regulator, hereinafter the controller, is designed for continuous smooth fan speed control.

DELIVERY SET

The delivery set includes:

1. Controller - 1 item;
2. Self-tapping screws with dowels:
 - 2 sets for wall surface mounting;
 - 4 sets for wall flush mounting;
3. Spare fuse
 - 1.5 A (for CDT(E) E1), 2.0 A (for CDT(E) E1.5), 2.5 A (for CDT(E) E2),
 - 3.15 A (for CDT(E) E2.5) - 1 item;
4. Plastic screwdriver - 1 item;
5. User's manual;
6. Packing box.

DESIGNATION KEY

CDTE E1

Maximum current [A]:

1; 1.5; 2; 2.5

E: Single-phase

Mounting option:

CDTE: wall surface mounting;

CDT: wall flush mounting

Designation key example:

CDTE E1 - single-phase speed controller with maximum current 1 A for wall surface mounting.

MAIN
TECHNICAL DATA

Appliance type	CDT(E)	CDT(E)	CDT(E)	CDT(E)
	E1	E1,5	E2	E2,5
Input voltage, 50 Hz [V]	220–240			
Max. output power [VA]	230	345	460	575
Max. load current [A]	1	1,5	2	2,5
Overall dimensions [mm]	162x80x70			
Weight [g]	300			

The controller front panel is shown on fig. 4.
The control knob position corresponds to the fan rotation speed.
The control internal design is shown on fig .5.

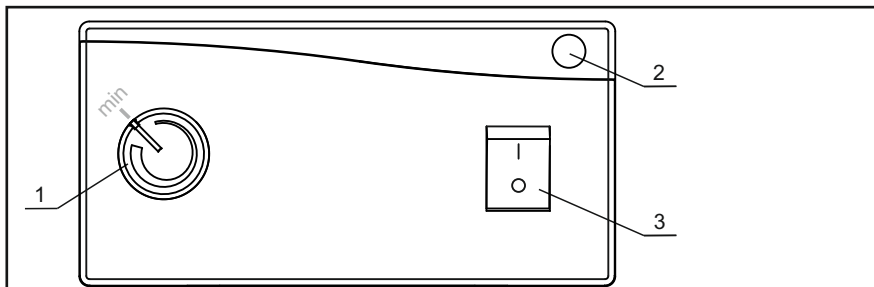

4 1 - Speed control knob; 2 - Operation lamp; 3 - Switch.

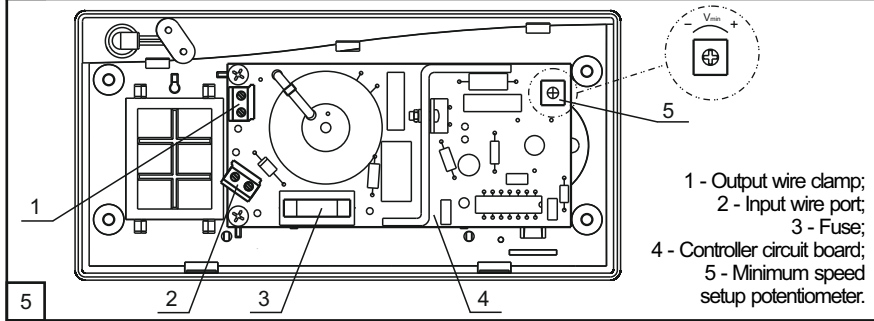

5 1 - Output wire clamp;
2 - Input wire port;
3 - Fuse;
4 - Controller circuit board;
5 - Minimum speed setup potentiometer.

CONNECTION TO
POWER MAINS

To connect the speed controller to the power mains follow the wiring connection diagram, Fig. 6.

Connection sequence:

- Remove the decorative front panel and the base, Fig. A and B;
- Route the wires through the ports 2, 6 in the controller casing;
- Strip the wire ends 7–8 mm long;
- Connect the wires to terminal blocks 8 and 9 (Fig. 2) according to the wiring connection diagram, Fig. 3;
- Secure the wires with clamps 1 and 5, Fig. 2;
- Re-install the base and the decorative front panel.

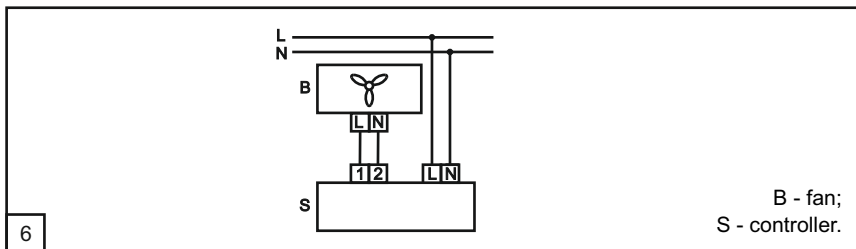

B - fan;
S - controller.

MINIMUM
SPEED SETTING

On the initial start set up the minimum speed of the connected fan.

To set the minimum rotation speed set the control knob 1, Fig. 4 on the front panel to the leftmost position and then gently rotate the control knob of potentiometer 5, Fig. 5 with the plastic screwdriver (included into the delivery) to the right or to the left until the fan starts rotating steadily.

The controller starts operation immediately upon supplying the power voltage to its input. If the appliance fails to operate, refer to Table 2 for troubleshooting.

TYPICAL FAULTS
AND FAULT
HANDLING

FAULT	PROBABLE REASON	FAULT HANDLING
The appliance fails to operate	Limited or no power supply	Check the appliance connection (see Connection to power mains) and ensure secure contact on the terminal blocks.
	Blown fuse.	Replace the fuse.

TABLE 2

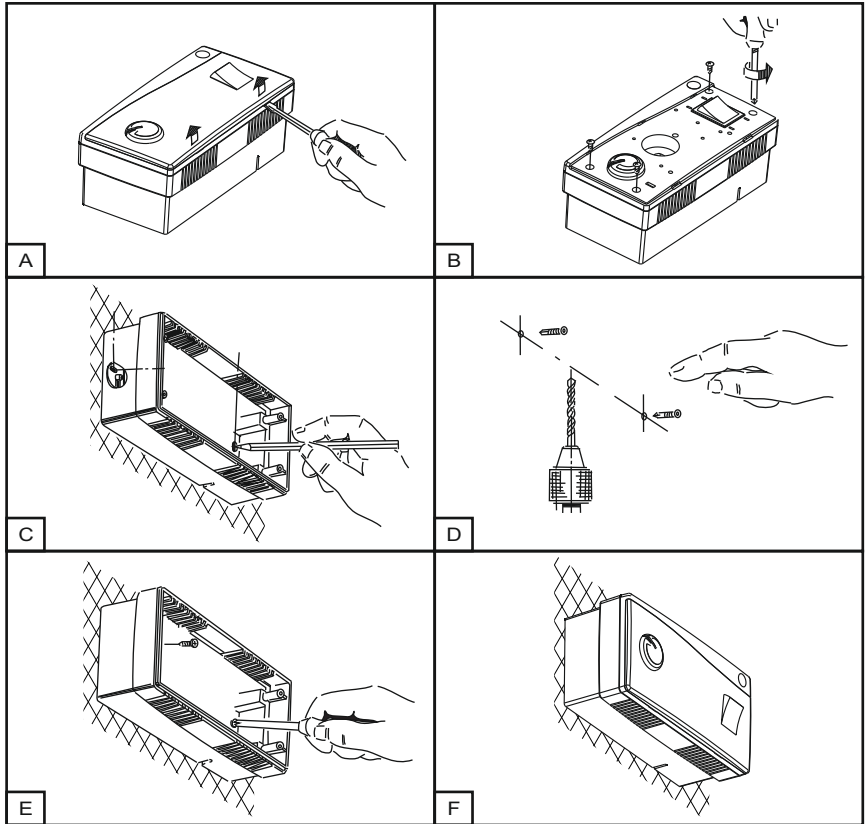
WALL SURFACE
MOUNTING

WALL FLUSH MOUNTING

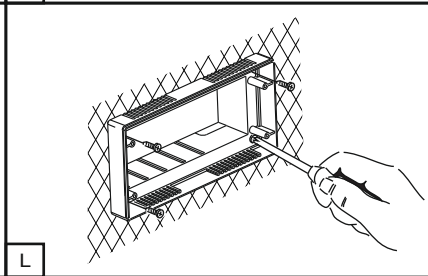
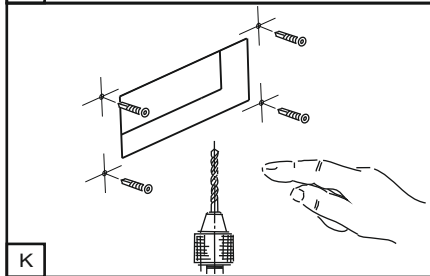
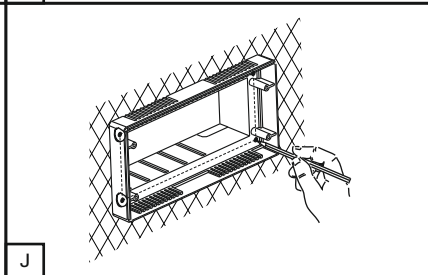
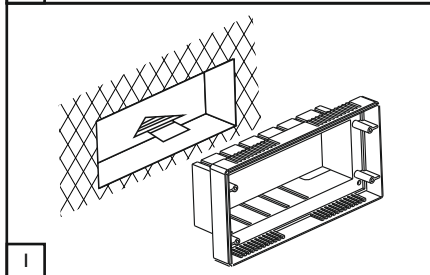
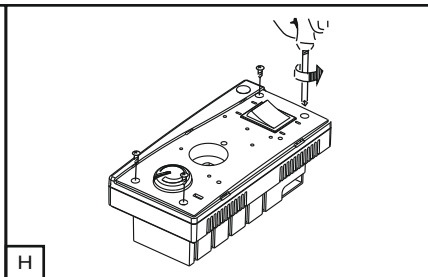
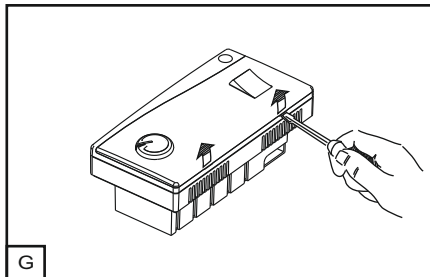

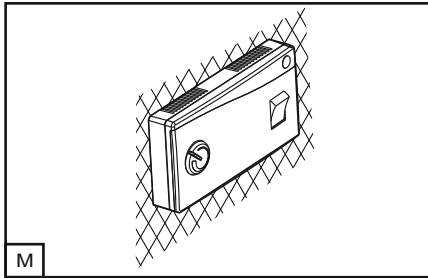

MANUFACTURER'S WARRANTY

By purchasing this product the customer confirms to have read and agreed to the terms, rules and requirements related to operation, storage, transportation, mounting, adjustment, connection, maintenance and repair as well as warranty obligations with respect to this product as set forth in the manufacturer's accompanying documentation to the product.

The manufacturing company sets forth the warranty period (service life) of the product as 12 months following the sale date via retail network subject to the customer's ensuring compliance with the rules of transportation, storage, mounting and operation of the product.

In case of any malfunction of the product through the fault of the Manufacturing company within the warranty period (service life), the customer shall have the right to elimination of the manufacturing defects by means of warranty servicing performed free of charge.

The warranty servicing implies performance of activities related to elimination of defects in the product aimed to provide intended use of the product by the customer. The defects are eliminated either by replacing or repairing such a product or a part (component) thereof.

NOTE: with the purpose of performing warranty servicing you please produce User Manual or other relevant substituting document and the payment document as an evidence of the purchase with indication of the sale date.

The product model shall comply with that one specified in the User Manual or other relevant substituting document.

With the purpose of performing warranty servicing please contact the trade company where you purchased the product. If warranty servicing on the spot proves impossible, you will be provided with the necessary information regarding rendering of this service.

Manufacturer's warranty shall not apply in the following cases:

- in case the customer fails to provide the product in complete according to the package contents specified in the User Manual or other relevant substituting document, including any components disassembled by the customer;
- in case of incompliance of the model or marking of the product with data specified on the product packaging and in the User Manual or other relevant substituting document;
- in case of non-timely technical maintenance of the product by the customer (dust, mud, oil condensate, foreign particles);
- in case of causing external damage to the product by the customer ('damage' shall not apply to external changes of the product required for the product mounting);
- in case of altering the product design or further reworking of the product;
- in case of replacing and using parts, units and components of the product not prescribed by the manufacturing company;
- in case of other use of the product other than intended use;
- in case of the customer's violating product operation rules;
- in case of connecting the product to electric mains of voltage exceeding voltage value specified in the user's manual;
- in case of step voltage that resulted in the product failure;
- in case of the customer's performing unauthorised repair of the product;
- in case of performing repair of the product by third persons unauthorized by the manufacturing company;

in case of warranty period (service life) expiry;
in case of the customer's violating transportation rules assuring prevention of damaging and/or destruction of the product;
in case of the customer's violating product storage rules;
in case of performing unlawful actions by third persons with respect to the product;
in case of force majeure (fire, flood, earthquake, war, hostilities of any kind, blockade);
in case of absent seals, provided such seals are prescribed by the User Manual or other relevant substituting document;
in case of unavailable warranty card;
in case of unavailable payment document to confirm the purchase with indication of the sale date.

The manufacturing company shall be responsible for defects arising through its fault prior to the moment of transferring the product to the ownership of the customer.

The manufacturing company shall not be responsible for defects arising after transferring the product to the customer and caused by the customer's violating the rules of transportation, storage, assembly and operation of the product, or by actions of third persons, an accident or force majeure circumstances.

The manufacturing company shall not be responsible for damage to health and property of the customer caused by the customer's violating the User Manual or other relevant substituting document; other use of the product by the customer other than its intended use, or by failure of the customer to comply with warnings and other information on the product specified in the User Manual or other relevant substituting document, or by the customer's violating the rules of transportation, storage, mounting, maintenance and operation of the product.

TRANSPORTATION AND STORAGE RULES

Transportation is allowed by any transportation vehicle provided that the product is in the manufacturer's original package.

Store the delivered product in the manufacturer's original packing box in a dry ventilated premise with the ambient temperature

from +5 °C up to + 40 °C and relative humidity less than 80 %.

The storage environment must be free of dust, acid or alkali vapours to prevent corrosion.

DISPOSAL

Do not dispose in domestic waste. The unit contains in part material that can be recycled and in part substances that should not end up as domestic waste.

Dispose of the unit once it has reached the end of its working life according to the regulations valid where you are.

MANUFACTURER'S WARRANTY

The fan complies with the requirements according to the EU norms and directives, to the relevant EU-Low Voltage Equipment Directives, EU-Directives on Electromagnetic Compatibility.

We hereby declare that the following product complies with the essential protection requirements of Electromagnetic Council Directive 2004/108/EC, 89/336/EEC and Low Voltage Directive 2006/95/EC, 73/23/EEC and CE-marking Directive 93/68/EEC on the approximation of the laws of the Member States relating to electromagnetic compatibility. This certificate is issued following test carried out on samples of the product referred to above. Assessment of compliance of the product with the requirements relating to electromagnetic compatibility was based on the following standards.

Protection degree index according to IP rating against access to hazardous parts and water ingress – IP55.

The fan does not require grounding.

The manufacturer hereby warrants normal operation of the fan over the period of five years from the retail sale date provided observance of the installation and operation regulations.

In case of failure due to faulty equipment during the warranty period the consumer has the right to exchange it.

If case of no confirmation of the sale date, the warranty term shall be calculated from the manufacturing date.

The replacement is offered by the Seller.

Warning!

The MANUFACTURER shall not be liable for any damage resulting from any misuse of or gross mechanic interference with the fan.

Thyristor speed controller

CDT E1
CDTE E1
CDT E1.5
CDTE E1.5
CDT E2
CDTE E2
CDT E2.5
CDTE E2.5

ACCEPTANCE
CERTIFICATE

Fan speed switch

Control unit

is recognized as serviceable

mark the proper model

Approval mark

Sold
(name and stamp of the trade company)

Manufacturing date

Date of sale

