

# Centro EC

## Inline centrifugal fans with EC motor

### Use

- Supply and exhaust ventilation and air conditioning systems of various premises requiring cost-saving controllable ventilation.
- The best ventilation solution for exhaust ventilation of bathrooms, kitchens and other humid premises.
- Compatible with Ø 100 up to 315 mm round air ducts.



**Air flow:**  
up to 1500 m<sup>3</sup>/h  
417 l/s



**Power:**  
from 82 W



**Noise level:**  
from 40 dBA



### Design

- Durable, impact-resistant and corrosion-free ABS-plastic casing.
- Aerodynamically shaped casing.
- Airtight terminal box for connection to power mains.

### Motor

- High-efficient direct current EC motor with external rotor and backward curved blades.
- EC technology meets the up-to-date requirements to energy-saving and controllable ventilation and provides up to 35 % energy saving as compared to asynchronous motors.
- EC motor ensures totally controllable speed range for the fan and has integrated overheating protection with automatic restart.
- EC motor has no friction and wearing parts as capacitor and brushes. Instead a maintenance-free EC controller electronic circuit board is used.
- The impeller is dynamically balanced.
- The fan is compatible with 50 Hz and 60 Hz power mains and the maximum speed does not depend on power mains frequency.

### Speed control

- The fan speed is controlled with a 0-10 V control signal from the following sources:
  - integrated or external speed controller
  - controller with sensors
  - central BMS system.
- The control signal value changes depending on air temperature, pressure, smoke concentration and other parameters.
- During signal value change the fan with EC motor correspondingly changes the rotations speed and delivers required air volume to the ventilation system.
- The computer central building management systems (BMS) enable integration of several EC motors in network and precise individual operation control for each fan.

### Mounting

- The fans are designed for duct mounting in any point of the ventilation system with the casing mounted at any angle. In case of vertical mounting a protective outer hood must be installed on the top.
- Fixation to the floor wall or ceiling is performed with the supplied mounting brackets.
- Electric connection and installation must be performed in compliance with the manual and the wiring diagram on the terminal box.



Mounting bracket for easy installation supplied with the fan

### Modifications and options

- FR1:** smooth speed controller adjustable from 0 to 100 % and power cable with mains plug.



Centro EC FR1 with an integrated speed controller and power cable

### Accessories

Silencers	Filter boxes	Electric heaters	Water heaters	Backdraft air dampers	Air dampers	Speed controllers
						
SD	KFBK / KFBT	EKH	WKH	VRV	VK / VKA	CDT E/0-10



- o **G1**: speed controller, temperature controller with external temperature sensor (cable length 4 m), power cable with mains plug.
- o **G11**: speed controller, temperature controller with integrated temperature sensor and power cable with mains plug. The **G1** and **G11** modifications enable automatic speed control depending on indoor temperature. The optimal ventilation solution for premises requiring permanent temperature control as greenhouses, orangeries, etc.
- o **W1**: power cable with mains plug.

Designation key			
Series	Motor	Spigot diameter [mm]	Options
Centro	EC: electronically commutated motor	100; 125; 150; 200; 250; 315	<b>FR1</b> : smooth speed controller adjustable from 0 to 100 % and power cable with mains plug <b>G1</b> : speed controller, temperature controller with external temperature sensor, power cable with mains plug <b>G11</b> : speed controller, temperature controller with integrated temperature sensor and power cable mains plug <b>W1</b> : power cable with mains plug

### Overall dimensions [mm]

Model	∅ D	∅ D1	B	L	L1	L2	L3	Weight [kg]
Centro EC 100	100	250	270	230	30	27	30	2.0
Centro EC 125	125	250	270	220	30	27	30	2.2
Centro EC 150	150/160	300	310	286	30	30	30	2.5
Centro EC 200	200	340	354	276	30	30	40	3.0
Centro EC 250	250	340	354	265	30	30	40	4.3
Centro EC 315	315	400	414	276	40	55	40	4.9

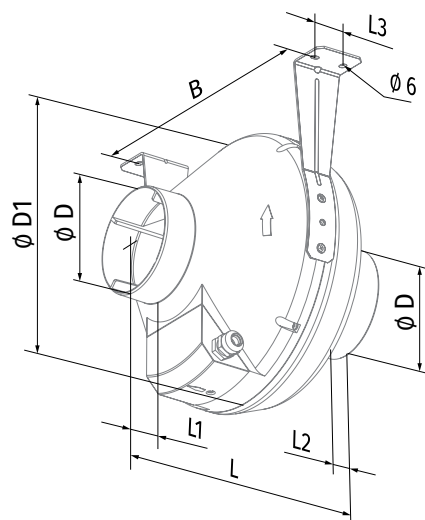

**Technical data**

Parameters	Centro EC 100	Centro EC 125	Centro EC 150
Voltage [V]	1 ~ 230	1 ~ 230	1 ~ 230
Frequency [Hz]	50	50	50
Power [W]	82	84	82
Current [A]	0.62	0.64	0.63
Maximum air flow [m <sup>3</sup> /h (l/s)]	340 (94)	420 (117)	630 (175)
RPM [min <sup>-1</sup> ]	3400	3600	3400
Sound pressure level at 3 m [dBA]	40	42	45
Transported air temperature [°C]	-25...+60	-25...+60	-25...+60
SEC class	B	B	B
IP rating	IPX4	IPX4	IPX4
Motor IP rating	IP44	IP44	IP44
ErP	2018	2018	2018

**CENTRO EC 100**

Sound power level, A-weighted	Total	Octave frequency bands [Hz]								LpA 3 m	LpA 1 m
		63	125	250	500	1000	2000	4000	8000		
L <sub>WA</sub> to inlet [dBA]	85	62	77	83	75	69	65	59	48	64	74
L <sub>WA</sub> to outlet [dBA]	84	69	77	82	74	66	62	57	46	63	73
L <sub>WA</sub> to environment [dBA]	61	29	44	52	56	55	54	44	31	40	50

Point	Power [W]	Point	Power [W]
1	82	11	28
2	82	12	25
3	81	13	17
4	81	14	16
5	51	15	15
6	50	16	13
7	45	17	8
8	40	18	8
9	32	19	7
10	30	20	6

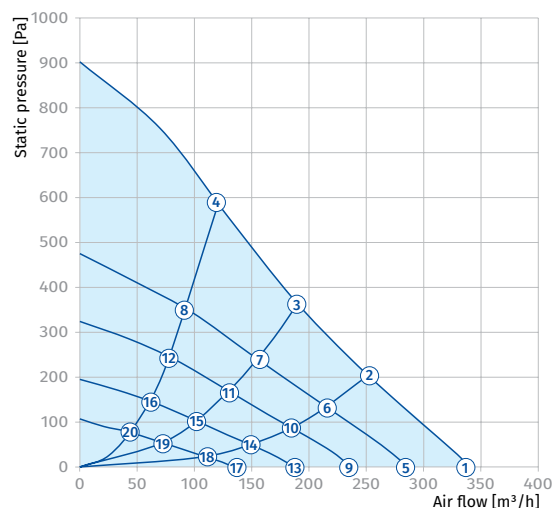

**CENTRO EC 125**

Sound power level, A-weighted	Total	Octave frequency bands [Hz]								LpA 3 m	LpA 1 m
		63	125	250	500	1000	2000	4000	8000		
L <sub>WA</sub> to inlet [dBA]	<b>87</b>	59	79	86	75	71	68	62	52	<b>67</b>	<b>77</b>
L <sub>WA</sub> to outlet [dBA]	<b>86</b>	66	79	85	74	68	65	60	50	<b>66</b>	<b>76</b>
L <sub>WA</sub> to environment [dBA]	<b>62</b>	26	46	55	56	57	57	47	35	<b>42</b>	<b>52</b>

Point	Power [W]	Point	Power [W]
1	84	11	29
2	82	12	24
3	82	13	18
4	81	14	17
5	51	15	16
6	50	16	14
7	48	17	8
8	45	18	8
9	31	19	7
10	30	20	7

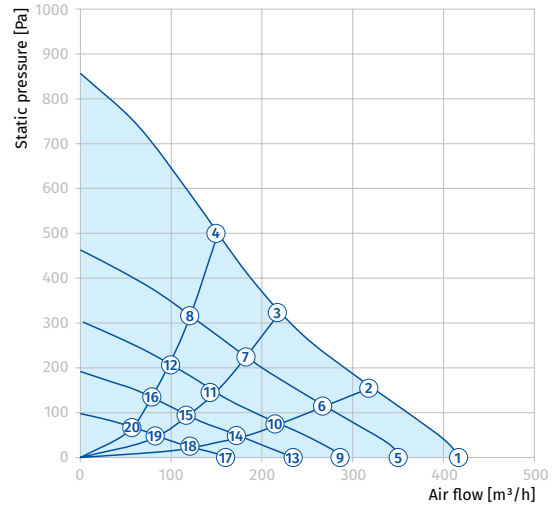

**CENTRO EC 150**

Sound power level, A-weighted	Total	Octave frequency bands [Hz]								LpA 3 m	LpA 1 m
		63	125	250	500	1000	2000	4000	8000		
L <sub>WA</sub> to inlet [dBA]	<b>93</b>	55	90	89	77	76	73	70	56	<b>72</b>	<b>82</b>
L <sub>WA</sub> to outlet [dBA]	<b>93</b>	55	91	88	74	73	68	67	54	<b>72</b>	<b>82</b>
L <sub>WA</sub> to environment [dBA]	<b>66</b>	26	48	58	61	60	59	51	39	<b>45</b>	<b>55</b>

Point	Power [W]	Point	Power [W]
1	82	11	31
2	82	12	27
3	82	13	17
4	82	14	17
5	54	15	17
6	57	16	16
7	53	17	9
8	49	18	9
9	32	19	8
10	33	20	8

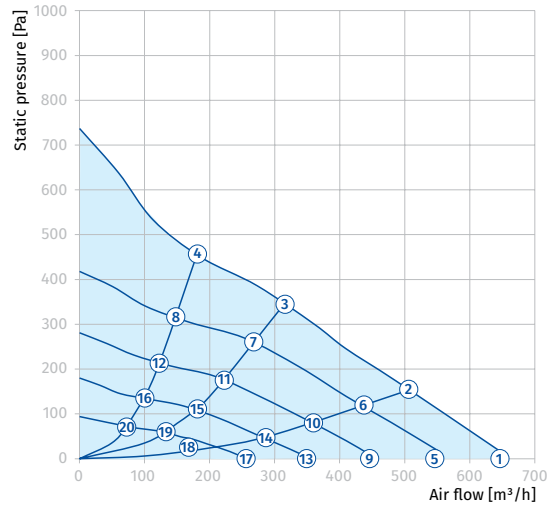

Parameters	Centro EC 200	Centro EC 250	Centro EC 315
Voltage [V]	1 ~ 230	1 ~ 230	1 ~ 230
Frequency [Hz]	50	50	50
Power [W]	84	165	165
Current [A]	0.64	1.1	1.15
Maximum air flow [m <sup>3</sup> /h (l/s)]	885 (246)	1250 (347)	1500 (417)
RPM [min <sup>-1</sup> ]	2700	2600	2500
Sound pressure level at 3 m [dBA]	47	48	48
Transported air temperature [°C]	-25...+60	-25...+60	-25...+60
SEC class	B	-	-
IP rating	IPX4	IPX4	IPX4
Motor IP rating	IP44	IP44	IP44
ErP	2018	2018	2018

### CENTRO EC 200

Sound power level, A-weighted	Total	Octave frequency bands [Hz]								LpA 3 m	LpA 1 m
		63	125	250	500	1000	2000	4000	8000		
L <sub>WA</sub> to inlet [dBA]	<b>87</b>	48	76	84	79	79	80	72	61	<b>67</b>	<b>77</b>
L <sub>WA</sub> to outlet [dBA]	<b>85</b>	45	75	79	77	77	80	72	62	<b>64</b>	<b>74</b>
L <sub>WA</sub> to environment [dBA]	<b>67</b>	27	49	60	62	61	60	52	39	<b>47</b>	<b>57</b>

Point	Power [W]	Point	Power [W]
1	84	11	32
2	84	12	31
3	83	13	16
4	82	14	18
5	51	15	18
6	54	16	17
7	58	17	8
8	55	18	8
9	28	19	9
10	32	20	8

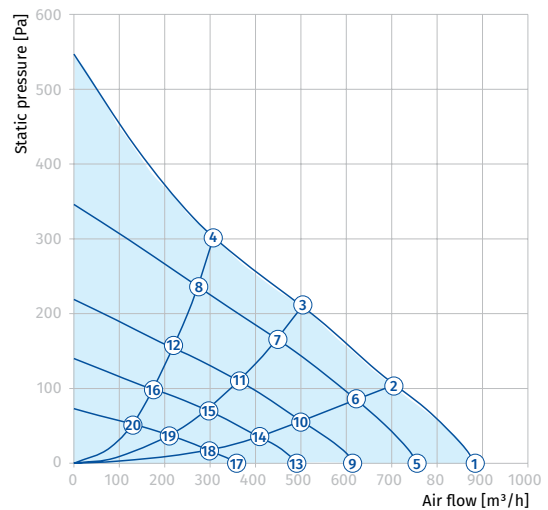

### CENTRO EC 250

Sound power level, A-weighted	Total	Octave frequency bands [Hz]								LpA 3 m	LpA 1 m
		63	125	250	500	1000	2000	4000	8000		
L <sub>WA</sub> to inlet [dBA]	<b>89</b>	60	77	84	82	84	80	76	64	<b>69</b>	<b>79</b>
L <sub>WA</sub> to outlet [dBA]	<b>87</b>	63	76	72	81	83	81	76	62	<b>67</b>	<b>77</b>
L <sub>WA</sub> to environment [dBA]	<b>68</b>	30	49	58	62	65	61	52	38	<b>48</b>	<b>58</b>

Point	Power [W]	Point	Power [W]
1	152	11	89
2	161	12	78
3	165	13	37
4	154	14	40
5	121	15	43
6	131	16	38
7	140	17	16
8	125	18	17
9	76	19	18
10	83	20	16

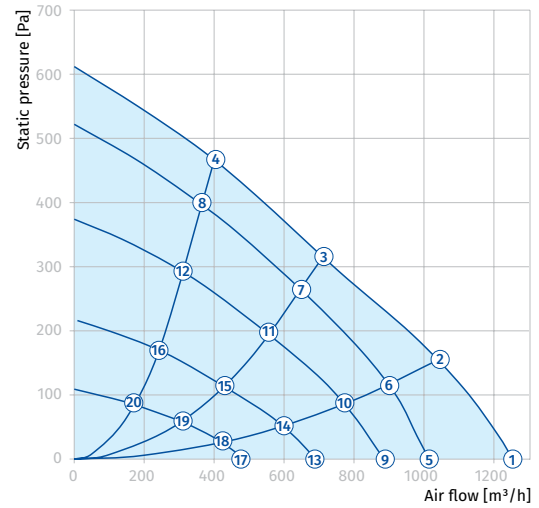

### CENTRO EC 315

Sound power level, A-weighted	Total	Octave frequency bands [Hz]								LpA 3 m	LpA 1 m
		63	125	250	500	1000	2000	4000	8000		
L <sub>WA</sub> to inlet [dBA]	<b>86</b>	51	73	71	75	81	82	77	68	<b>66</b>	<b>76</b>
L <sub>WA</sub> to outlet [dBA]	<b>87</b>	55	66	76	73	81	84	77	69	<b>67</b>	<b>77</b>
L <sub>WA</sub> to environment [dBA]	<b>69</b>	30	48	56	62	64	64	56	49	<b>48</b>	<b>58</b>

Point	Power [W]	Point	Power [W]
1	149	11	90
2	164	12	84
3	165	13	37
4	158	14	39
5	94	15	45
6	106	16	41
7	112	17	17
8	104	18	19
9	74	19	19
10	83	20	17

