



SINGLE ROOM AIR HANDLING UNIT WITH HEAT RECOVERY



FRESHBOX 60



OPERATION MANUAL

CONTENTS

Introduction	3
General	3
Safety rules	3
Storage and transportation rules	3
Manufacturer's warranty	3
Unit design and operating logic	4
Delivery set	4
Technical data	5
Mounting and operation guidelines	5
Connection to power mains and control	8
Maintenance	9
Troubleshooting	9
Acceptance certificate	10
Connection certificate	10
Warranty card	10

BLAUBERG Ventilation GmbH is happy to offer your attention a new high-quality single room air handling unit with heat recovery FRESHBOX 60. The solid team of high-qualified professionals with many years of working experience, technological innovations in design and production, high-quality components and materials from the top worldwide producers have become the precondition for the best single room air handling unit in its class.

INTRODUCTION

The present service instruction contains technical description, technical data sheets, operation and mounting guidelines, safety precautions and warnings for safe and correct operation of the unit.

GENERAL

The single-room unit is designed for efficient energy saving supply and exhaust ventilation of flats, houses, cottages and other small premises.

The unit is for wall mounting.

The unit is designed for continuous operation always connected to power mains.

SAFETY RULES

The unit complies with the requirements according to the EU norms and directives, to the relevant EU-Low Voltage Equipment Directives, EU-Directives on Electromagnetic Compatibility.

All operations related to the unit electrical connections, servicing and repair works are allowed only after the unit is disconnected from power mains.

All mounting and servicing operations are allowed for duly qualified electricians with valid electrical work permit for electric operations at the units up to 1000 V after careful study of the present user's manual.

The unit must be grounded!

Please follow the safety regulations and working instructions (DIN EN 50 110, IEC 364).

Make sure the impeller and the casing are not damaged before connecting the unit to power mains. The casing internals must be free of any foreign objects which can damage the impeller blades.

Disconnect the unit from power mains prior to any operations related to the unit servicing and repair works.

Take measures to prevent contact with the fan to avoid physical damages during the unit test and start-up.

Misuse of the product or any unauthorized modification are not allowed.

The unit is designed for connection to AC single-phase power mains, see "Technical Data". The unit is rated for permanent operation during non-stop power supply.

Take steps to prevent ingress of smoke, carbon monoxide and other combustion products into the room through open chimney flues or other fire-protection devices. Sufficient air supply must be provided for proper combustion and exhaust of gases through the chimney of fuel burning equipment to prevent back drafting. The maximum permitted pressure difference per living units is 4 Pa.

The transported air must not contain any dust or other solid impurities,

sticky substances or fibrous materials. The unit is not designed for use in an inflammable and explosive medium.

The transported air must not have an aggressive effect on steel at the temperature stated in the table 1 of the section "Technical data".

Do not close or block the unit intake or exhaust vent not to disturb the normal air passage. Do not sit on the unit and do not put objects on the unit.

Follow the manual guidelines to ensure trouble-free operation and long service life of the product.

Hazardous parts access and water ingress protection standard IP22.

STORAGE AND TRANSPORTATION RULES

Transportation of the unit is allowed by any vehicle provided the unit is transported in the original package and is protected against weather and mechanical damages.

Use hoist machinery for handling and transportation to prevent possible mechanical damages of the unit. Fulfil the requirements for transportation of the specified cargo type during cargo-handling operations.

Store the unit in a dry and cool place in the original packing.

The storage environment must not be subjected to any aggressive and/or chemical evaporations, admixtures, foreign objects that may provoke corrosion and damage connection tightness.

Store the unit in an environment with minimized risk of mechanical damages, temperature and humidity fluctuations.

Do not expose the unit to the temperatures below +5°C and above +40 °C .

Connection of the unit to power mains is allowed after the unit has been kept indoor for minimum two hours.

MANUFACTURER'S WARRANTY

The product complies with the requirements according to the EU norms and directives, to the relevant EU-Low Voltage Equipment Directives, EU-Directives on Electromagnetic Compatibility.

We hereby declare that the following product complies with the essential protection requirements of Electromagnetic Council Directive 2004/108/EC, 89/336/EEC and Low Voltage Directive 2006/95/EC, 73/23/EEC and CE-marking Directive 93/68/EEC on the approximation of the laws of the Member States relating to electromagnetic compatibility.

The manufacturer hereby warrants normal operation of the unit over the period of 2 years from the retail sale date provided observance of the installation and operation regulations.

In case of failure due to manufacturing fault during the warranty period the consumer has the right to exchange it.

If case of no confirmation of the sale date, the warranty period shall be calculated from the manufacturing date.

The replacement is offered by the Seller.

The manufacturer shall not be liable for any damage resulting from any misuse of or gross mechanical interference with the unit.

Fulfil the operation manual requirements to ensure a trouble-free and long service life of the unit.



ATTENTION

The product is not allowed for use by children and persons with reduced physical, mental or sensory capacities, without proper practical experience or expertise, unless they are controlled or instructed on the product operation by the person(s) responsible for their safety. Supervise the children and do not let them play with the product.

WARNING

Do not dispose in domestic waste.



The unit contains in part material that can be recycled and in part substances that should not end up as domestic waste.

Dispose of the unit once it has reached the end of its working life according to the regulations valid where you are.

UNIT DESIGN AND OPERATING LOGIC

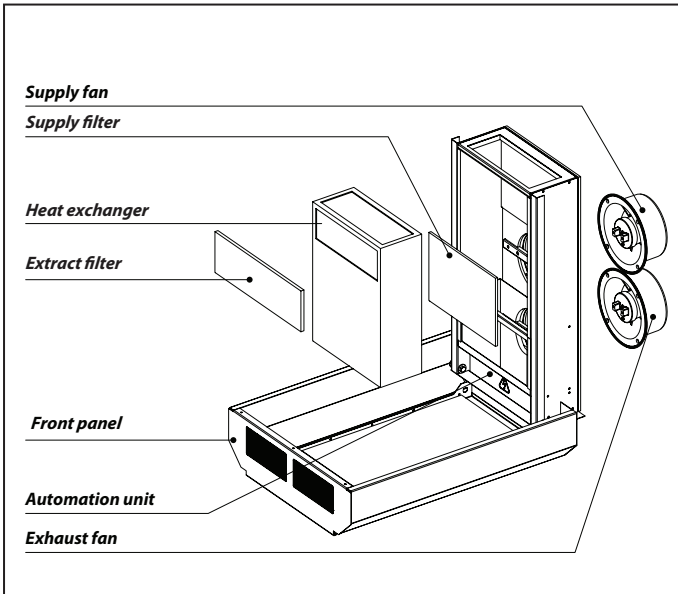

Fig. 1. Unit design

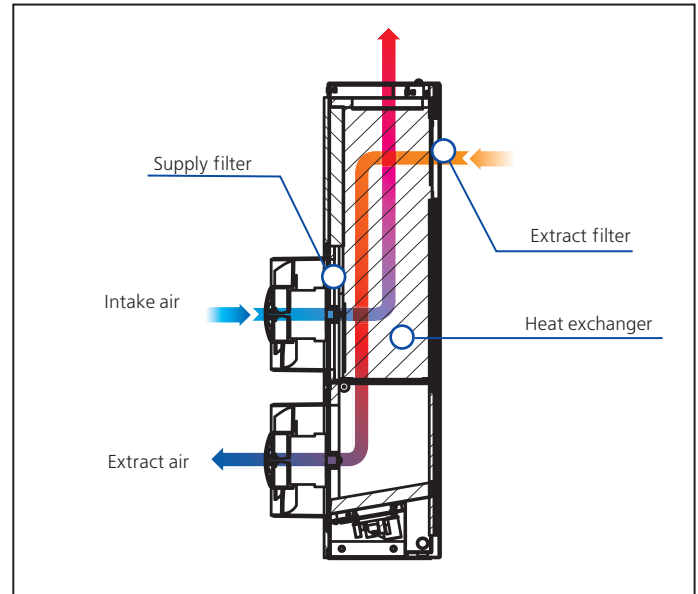

Fig. 2. Operation logic

The compact casing is made of polymer coated steel and has a 15 mm thermal and sound insulation of PE foam film. The front panel serves for accessing to the unit internals.

The unit is powered through an integrated power supply unit with a wide range of supply voltage from 100 to 240 V and frequency 50-60 Hz. The unit is supplied with a power cord with a standard adapter and is compatible with round Ø125 mm air ducts.

Axial EC fans provide air supply and air extract. EC motor technologies meet the latest engineering demands for energy saving and for high-efficient ventilation. Due to EC technology the single room air handling unit is featured with a low energy demand. The fan motors are equipped with built-in thermal overheating protection with automatic restart and ball bearings for longer service life.

The unit incorporates a plate counter-flow plastic heat exchanger with large surface area and high efficiency. Recuperating efficiency reaches 79%. The air flows are fully separated within the heat exchanger. Odours and contaminants contained in the extract air are not transferred to the supply air

flow.

Heat recovery is based on the utilization of the thermal energy of the extract air for heating up the supply air. The extract air transfers most of its heat to the intake air flow. This reduces thermal energy losses in cold seasons. In summer the heat exchanger performs reverse and transfers cold from the cooled extract air for cooling the warm intake air. This contributes to better performance of the air conditioner in ventilated premises.

The integrated protection system is used for freezing protection of the unit in cold seasons. The temperature sensor is installed in the section behind the heat exchanger before the extract fan and is used for freezing protection of the unit. If the exhaust temperature drops below +3 °C the heat exchanger freezing danger is registered. In this case the supply fan is turned off and the unit operates in exhaust mode which enables the heat exchanger get warmed up with extract air. After freezing danger is off the unit reverts to the standard operation mode.

The unit is equipped with BLAUBERG SGR-3/1 sensor speed switch for the unit speed changeover.

DELIVERY SET

- ✓ Unit - 1 item;
- ✓ Sensor speed switch - 1 item;
- ✓ Power cable - 1 item;
- ✓ Fasteners (screw 5.0x50 – 2 items; dowel 8x40 - 2 items);

- ✓ Operation manual - 1 item;
- ✓ Master plate - 1 item;
- ✓ Packing box - 1 item.

TECHNICAL DATA

Table 1. Technical data of the unit

Parameters	FRESHBOX 60		
Unit voltage / 50-60 Hz [V]	100-240		
Speed	min	med	max
Power [W]	4.2	9.6	15.4
Current [A]	0.02	0.04	0.07
Max. air flow [m ³ /h]	30	45	60
RPM	1165	1720	2685
Sound pressure level at 3 m distance [dBA]	22	25	29
Max. transported air temperature [°C]	-20 up to +50		
Filter: extract/supply	G2		
Heat recovery efficiency [%]	79	74	70
Heat exchanger type	counter-flow		
Heat exchanger material	polystyrene		
Ingress Protection Rating	IP22		
Weight [kg]	10.3		

* Allowable deviation of the rated voltage: $\pm 10\%$.

**Noise level is measured at 3 m distance from the unit connected to the air ducts, in free room.

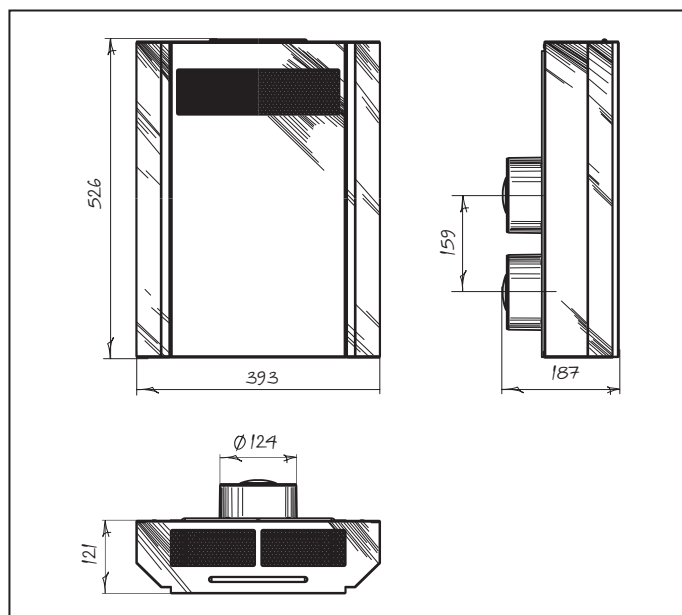

Fig. 3. Overall dimensions

MOUNTING AND OPERATION GUIDELINES

The unit is mounted with the master plate from the delivery set, fig. 4. Please prepare also two air ducts of required length or one of the mounting sets (MS1 FRESHBOX 60 or MS2 FRESHBOX 60).

The mounting set MS1 FRESHBOX 60 is specially designed for mounting of the unit at general construction stage. It includes two plastic air ducts, each 500 mm long and two master plates for marking the holes on inner and outer wall sides.

The mounting set MS2 FRESHBOX 60 is specially designed for mounting of the unit in a ready-built premise. It includes two plastic air ducts, 500 mm long, a master plate for matching holes and an outer ventilation hood AH FRESHBOX 60 that prevents ingress of foreign objects inside the unit. If the building's wall thickness is above 500 mm, please prepare two $\varnothing 125$ mm air ducts of required length.

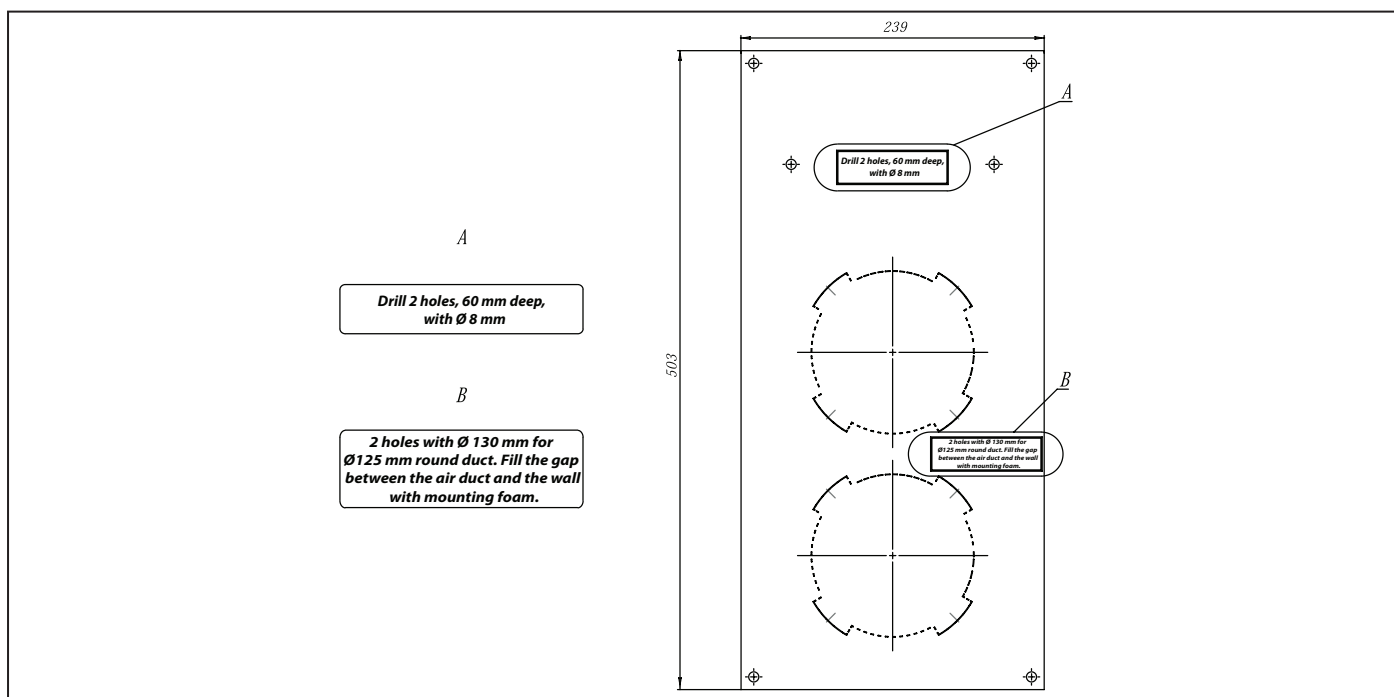

Fig. 4. Master plate

Unit mounting sequence:

1. Fix the master plate from the delivery set on the wall with a sealing tape on required level, fig. 5.
2. Use the master plate to mark two \varnothing 140 mm holes for the air ducts and two \varnothing 8 mm holes for the dowels.
3. Remove the master plate and drill through holes sloped down by 2-3% for the air ducts and the holes for the dowels, 60 mm deep. Then insert the dowels from the delivery set. Fig. 6
4. Remove the perforated holes for the air ducts from the master plate. Re-install it with a sealing tape. If you use either MS1 FRESHBOX 60 or MS2 FRESHBOX 60 set, fix the master plate from the mounting set on outer wall side to align the air ducts with respect to each other. Fix this master plate somewhat lower to ensure the minimum required slope by 3% to outside.
5. Inset the air ducts into the master plate holes and seal those with a mounting foam through the provided openings in the master plate, fig. 7. Install the air ducts sloped down by 2-3% outside to ensure the condensate drainage.
6. After the mounting foam hardening (see the solidification time in the product specification) remove the master plates. At the inner wall cut the

protruding parts of the air ducts to be flush with the wall. On outer wall side, the air ducts must protrude by 10 mm to prevent condensate dropping on the wall.

7. Mounting sequence of the unit:

- a) take off the front cover and remove the heat exchanger, fig. 8;
- b) connect the unit spigots to the air ducts, fig. 9;
- c) fix the unit to the wall with 5.0x50 screws (screws and matching dowels are included into the delivery set);
- d) Install the heat exchanger and the front panel.
- e) Mount the sensor speed switch, refer Connection to power mains and control, page 8.

Install the ventilation hood AH FRESHBOX 60 on the outer side of the building to prevent ingress of foreign objects into the air ducts, fig. 10. The hood is not included into the delivery set of FRESHBOX 60 unit and is available on separate order (with the mounting kit MS2 FRESHBOX 60 or as AH FRESHBOX 60). The ventilation hood AH FRESHBOX 60 may be replaced with any ventilation grille or a ventilation hood of respective size.

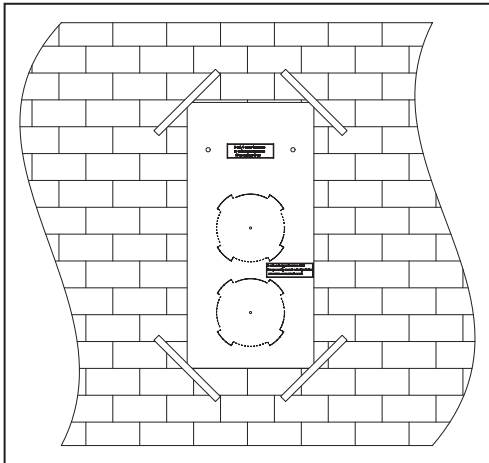

Fig. 5.

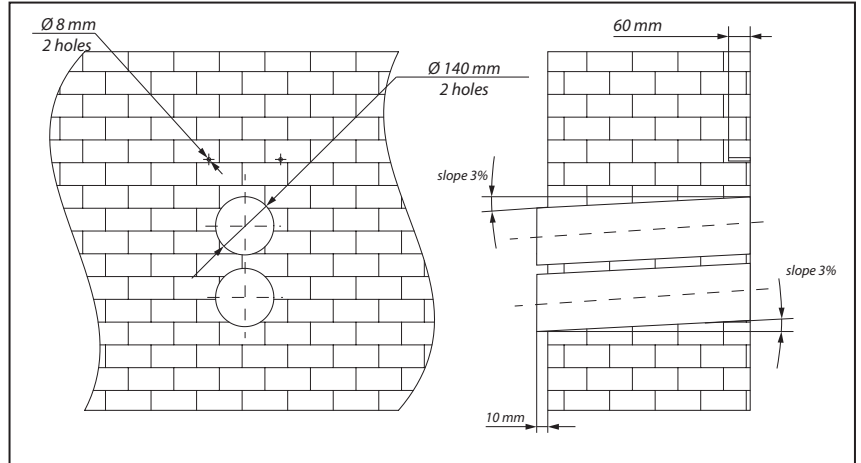

Fig. 6.

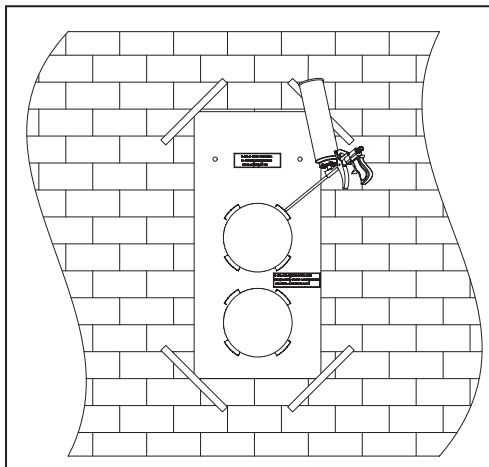

Fig. 7.

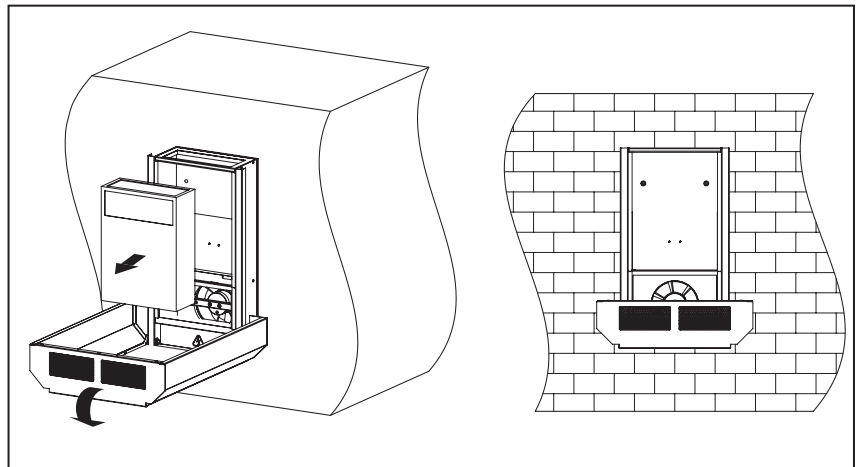

Fig. 8.

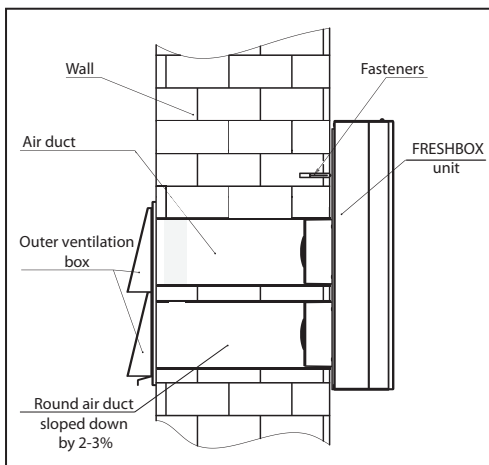

Fig. 9.

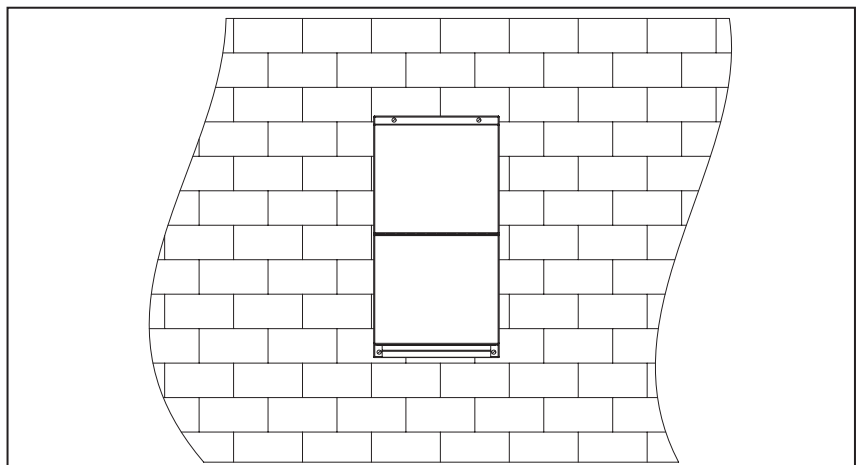
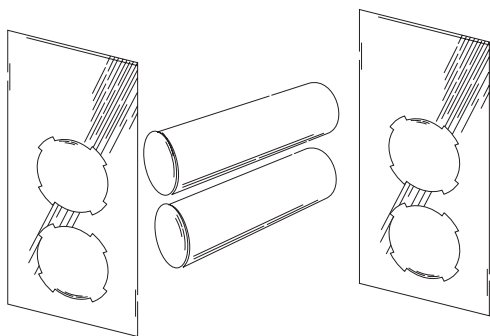

Fig. 10.

MS1 FRESHBOX 60 mounting set is designed to prepare a mounting place for installation of the unit FRESHBOX 60 at general construction stage.



The **MS1 FRESHBOX 60** mounting set includes:

- ✓ plastic air duct Ø 125 mm, 500 mm long – 2 items;
- ✓ paper master plate – 2 items.

MS2 FRESHBOX 60 mounting set is used for mounting of FRESHBOX 60 unit and is available upon separate order.

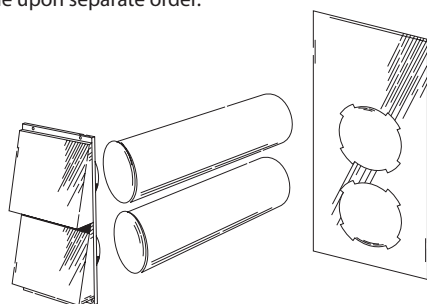

MS2 FRESHBOX 60 mounting set includes:

- ✓ plastic air duct Ø 125 mm, 500 mm long – 2 items;
- ✓ paper master plate – 1 item;
- ✓ outer ventilation box AH FRESHBOX 60 – 1 item;
- ✓ screw and dowel 8x40 – 4 items.

Mounting sequence of **MS2 FRESHBOX 60** set:

1. Fix the master plate from the delivery set on inner wall side with a sealing tape on required level, fig. 5.
2. Use the master plate to mark two Ø 140 mm holes for the air ducts and two Ø 8 mm holes for the dowels.
3. Remove the master plate and drill through holes sloped down by 2-3% for the air ducts and the holes for the dowels, 60 mm deep. Then insert the dowels from the delivery set. Fig. 6
4. Remove the perforated holes for the air ducts from the master plate. Re-install it with a sealing tape. If you use either MS1 FRESHBOX 60 or MS2 FRESHBOX 60 set, fix the master plate from the mounting set on outer wall side to align the air ducts with respect to each other. Fix this master plate

Mounting sequence of **MS1 FRESHBOX 60** set:

1. Fix one master plate from the into delivery set on the inner wall side with a sealing tape on required level, fig. 5.
2. Use the master plate to mark two Ø 140 mm holes for the air ducts and two Ø 8 mm holes for the dowels.
3. Remove the master plate and drill through holes sloped down by 2-3% for the air ducts and the holes for the dowels, 60 mm deep. Then insert the dowels from the delivery set. Fig. 6
4. Remove the perforated inserts for the air ducts from the master plate. Re-install it with a sealing tape. If you use either MS1 FRESHBOX 60 or MS2 FRESHBOX 60 set, fix the master plate from the mounting set on outer wall side to align the air ducts with respect to each other. Fix this master plate somewhat lower to ensure the minimum required slope by 3%.
5. Insert the air ducts into the master plate holes and seal those with a mounting foam through the provided openings in the master plate, fig. 7. Install the air ducts sloped down by 3% outside to ensure the condensate drainage.
6. After the mounting foam hardening (see the solidification time in the product specification) remove the master plates. At the inner wall cut the protruding parts of the air ducts to be flush with the wall. On outer wall side, the air ducts must protrude by 10 mm to prevent condensate dropping on the wall.

somehow lower to ensure the minimum required slope by 3%.

5. Insert the air ducts into the master plate holes and seal those with a mounting foam through the provided openings in the master plate, fig. 7. Install the air ducts sloped down by 3% to ensure the condensate drainage.
6. After the mounting foam hardening (see the solidification time in the product specification) remove the master plates. At the inner wall cut the protruding parts of the air ducts to be flush with the wall. On outer wall side, the air ducts must protrude by 10 mm to prevent condensate dropping on the wall.
7. Install the ventilation hood AH FRESHBOX 60 on the outer side of the building to prevent ingress of foreign objects into the air ducts, fig. 10.

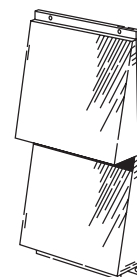

Mounting sequence of **AH FRESHBOX 60** ventilation hood:

- a) lean the ventilation hood AH FRESHBOX 60 against the wall;
- b) mark fastening holes;
- c) drill four Ø 8 mm holes, 40 mm deep;
- d) install dowels 8x40 from the ventilation hood delivery set;
- e) install the ventilation hood AH FRESHBOX 60;
- f) fix the ventilation hood AH FRESHBOX 60 with screws.

CONNECTION TO POWER MAINS AND CONTROL



WARNING

Read the operation manual prior to any electric installations. Connection of the unit to power mains is allowed by a qualified electrician only.

The rated electrical parameter are stated on the rating plate. No modifications of internal connections are allowed and will result in void warranty.

Connect the unit only to power mains with valid electric standards. The unit must be connected to a correct mounted socket with a grounded terminal or connected to a fixed installed cable.

Follow the respective electric standards, safety rules (DIN VDE 0100), TAB der EVUs.

The house cabling system must be equipped with an automatic switch at the external input. Connect the unit to power mains through the automatic switch. The contact gap on all poles at least 3 mm (VDE 0700 T1 7.12.2 / EN 60335-1).

Install the automatic switch to ensure prompt access.

The unit is rated for connection to single-phase alternating current power mains 1~100-240 V / 50-60 Hz.

The power cable is pre-wired to the unit to facilitate electric connection.

The unit is equipped with BLAUBERG SGR-3/1 sensor speed switch for operation mode control.

The sensor speed switch BLAUBERG SGR-3/1 is designed for switching on/off and operation mode selection:

- **mode 1.** The speed switch is in 1 position. Air flow 30 m3/h.
- **mode 2.** The speed switch is in 2 position. Air flow 45 m3/h.
- **mode 3.** The speed switch is in 3 position. Air flow 60 m3/h.

Touch a respective speed button to activate a required speed of the connected air handling unit.

Touch a respective speed button to change the selected speed. The respective speed button has blue highlighting. Touch a current fan speed button once again to turn the air handling unit off.

The sensor panel has no light indication when the unit is off. Every time the sensor panel is touched a sound signal is generated.

The control unit is installed under the protecting panel of the air handling unit, fig. 12.

The air handling unit is connected to the sensor speed switch via a four-wire wire, 3 m long, that is included into the delivery set. 12.

Each wire must have min. section 0.25 mm². The cable length from the unit to the sensor speed switch must not exceed 30 m.

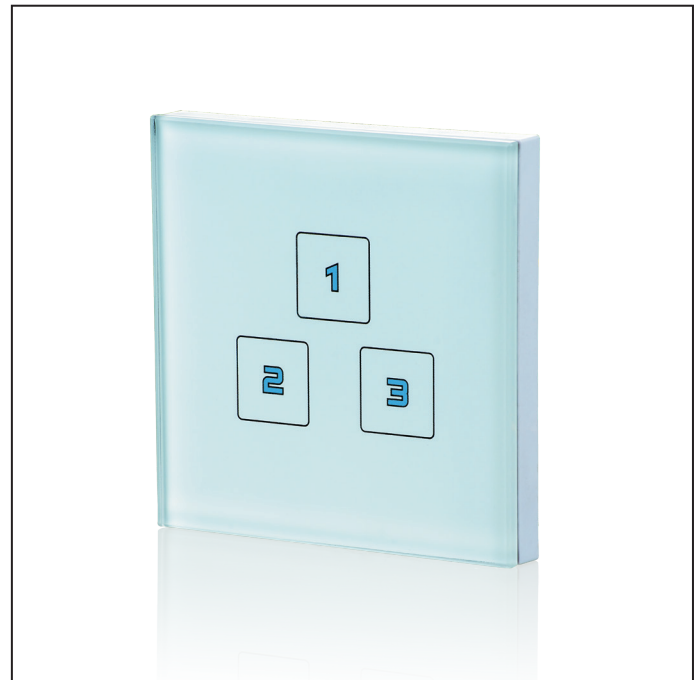

Fig.11. Sensor speed switch SGR-3/1

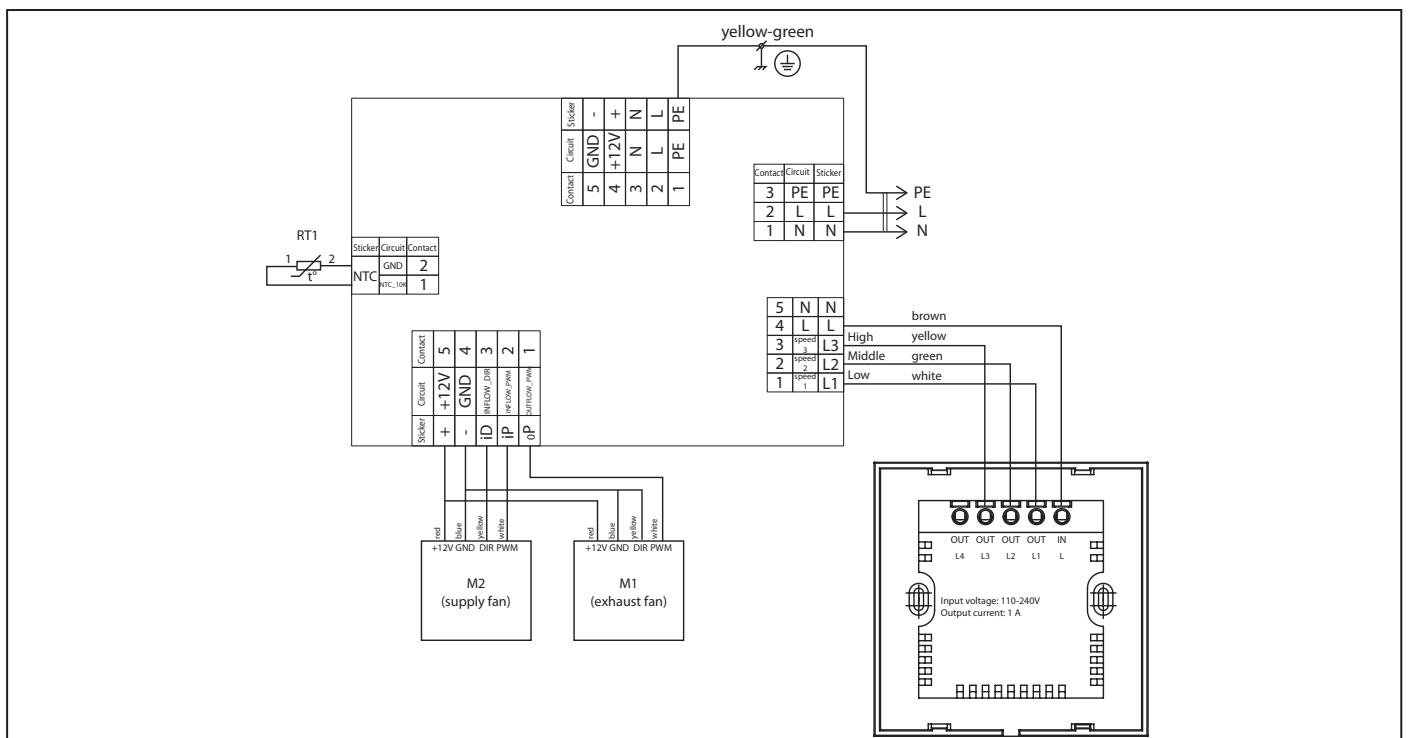

Fig. 12. Wiring diagram

Mounting sequence of the sensor speed switch, fig. 13:

1. Carefully undo the latches of the switch front panel with a screwdriver.
2. Remove the front panel.
3. Route the cable to the installation place of the speed switch.
4. Fix the back panel to the wall through the fixing holes.
5. Connect the control cable to the speed switch following the wiring diagram, fig. 12.
6. Install the speed switch front panel on the latches.

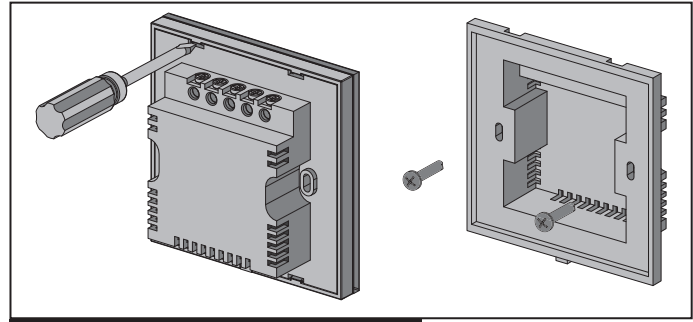

Fig. 13. SGR-3/1 sensor speed switch mounting

MAINTENANCE

Servicing of the unit is required 3-4 times per year.

Disconnect the unit from power mains prior to any maintenance operations. The unit maintenance includes regular cleaning of the unit surfaces and components from dust and filter cleaning or replacement.

To remove dust in the air handling unit use a soft brush, a cloth or compressed air. Do not use water, abrasive detergents, sharp objects and solvents. Clean the impeller blades once a year.

Soiled filters increase air resistance and decrease the unit performance. The

filters can be cleaned with a vacuum cleaner or with running water. Let the filters dry well at least for 24 hours. The filters require cleaning at least 3-4 times per year.

For accessing the unit filters open the front panel, fig. 1.

Regular cleaning is required to maintain the high heat recovery efficiency of the heat exchanger. To clean the heat exchanger use a vacuum cleaner or flush it under running water. And at least 24h to dry well.

TROUBLESHOOTING

Table 2. Error list and troubleshooting

Fault	Possible reasons	Remedy
The fan does not start when the unit is on.	No power supply.	Make sure of correct power supply, otherwise troubleshoot the connection error.
Cold supply air.	Extract filter is clogged.	Clean or replace the extract filter.
	The heat exchanger is frosted.	Check the heat exchanger for frosting. Shut the unit off if required and let ice melt.
Low air flow.	The filters, the fans or the heat exchanger are soiled.	Clean or replace the filters; clean the fans and the heat exchanger.
	The air ducts or the outer hood are soiled or mechanically damaged.	Clean or replace the damaged air ducts or the outer hood.
Noise, vibration.	The impeller blades are clogged.	Clean the impeller blades.
	Loose screw connection.	Tighten the fastening screws.

ACCEPTANCE CERTIFICATE

**The single room air handling unit with heat recovery
FRESHBOX 60
is recognizes as serviceable.**

The unit complies with the requirements according to the EU norms and directives, to the relevant EU-Low Voltage Equipment Directives, EU-Directives on Electromagnetic Compatibility.
We hereby declare that the following product complies with the essential protection requirements of Electromagnetic Council Directive 2004/108/EC, 89/336/EEC and Low Voltage Directive 2006/95/EC, 73/23/EEC and CE-marking Directive 93/68/EEC on the approximation of the laws of the Member States relating to electromagnetic compatibility.

This certificate is issued following test carried out on samples of the product referred to above.

Approval mark _____ Manufacturing date _____

ELECTRICAL CONNECTION CERTIFICATE

**The single room air handling unit with heat recovery
FRESHBOX 60
is connected to power mains in compliance with the operation manual requirements by the professional:**

Company: _____

Name _____

Date _____ Signature _____

WARRANTY CARD

SELLER

SALES DATE

REPRESENTATIVE IN EU

Blauberg Ventilatoren GmbH
Aidenbachstr. 52a
D-81379 Munich, Germany

