



Heat recovery air handling units

KOMFORT EC LW

Air capacity – up to 550 m³/h
Heat recovery efficiency – up to 90 %



Application

- ❑ Air handling units for efficient supply and exhaust ventilation in flats, houses, cottages and other buildings.
- ❑ For controllable mechanical energy saving ventilation systems.
- ❑ Heat recovery minimises ventilation heat losses.
- ❑ Control of air exchange for creating comfortable indoor microclimate.
- ❑ Compatible with round Ø150, 160 or 200 mm air ducts.

Design

- ❑ The casing is made of double-skinned aluzinc panels, internally filled with 25 mm mineral wool layer for heat and sound insulation.
- ❑ The casing has fixing brackets with vibration absorbing connectors for easy installation.
- ❑ The spigots for connection to the air ducts are located at the side of the unit and are rubber sealed for airtight connection to the air ducts.
- ❑ The hinged casing side panels ensure easy access to the internals for cleaning, filter replacement and other maintenance operations.

Fans

- ❑ High-efficient external rotor EC motors and centrifugal double-inlet impellers with forward curved blades are used for air supply and exhaust.
- ❑ EC motors have the best power consumption to air capacity ratio and meet the latest demands concerning energy saving and high-efficient ventilation.
- ❑ EC motors are featured with high performance, low noise level and totally controllable speed range.
- ❑ Dynamically balanced impellers.

Heat recovery

- ❑ The unit is equipped with a plate cross-flow polystyrene heat exchanger with a large surface area and high heat recovery efficiency.
- ❑ The air flows are fully separated within the heat exchanger. Odours and contaminants contained in the extract air are not transferred to the supply air flow.
- ❑ Heat recovery is based on the utilization of the thermal energy of the extract air for heating up supply air. Extract air transfers most of its heat to the intake air flow. Heat recovery reduces heat losses in cold seasons. In summer the heat exchanger performs reverse and intake air is cooled in the heat exchanger by the cool extract air. This contributes to better performance of the air conditioner in ventilated premises.
- ❑ The electronic protection system based on bypass and heater is used for freezing protection of the unit in cold seasons. The bypass damper is opened and the heater is turned on automatically according to temperature sensor readings. Cold intake air passes by the heat exchanger and is warmed up to set temperature in the heat exchanger. Synchronously extract air that passes by the heat exchanger is used for its defrosting. After a freezing danger is over the bypass damper is closed, the heater is turned off. The intake air flows again through the heat exchanger and absorbs the

accumulated heat. The unit reverts to the normal operation mode.

- ❑ The drain pan under the heat exchanger block is used for condensate collection and drainage.

Air heater

- ❑ The unit is equipped with a water (glycol) heater for operation at low outside air temperature.
- ❑ The integrated water heater is activated to warm up supply air flow if set indoor air temperature may not be reached by means of heat recovery only.
- ❑ Smooth water heater power control ensures automatic supply air temperature maintaining.
- ❑ The air temperature sensor downstream of the waterheating coils and the return water temperature sensor are used for freezing protection of the water heater.

Air filtration

- ❑ The built-in F7 cassette supply filter and G4 cassette extract filter provide efficient air filtration.

Control and automation

- ❑ The unit incorporates an integrated control system with a wall-mounted control panel and sensor display.
- ❑ The standard delivery set includes a 10 m cable for connection of the unit and the control panel.
- ❑ Control panel functions:
 - Activating/deactivating the unit.
 - Setting required fan speed.
 - Setting and maintaining supply air temperature.
 - Setting week-scheduled operation of the unit.
 - Displaying indoor air temperature.
- ❑ Automation functions:
 - Set supply air temperature maintaining by means of the heat medium regulating valve.
 - Controlling the heat exchanger bypass damper.
 - Controlling the circulating pump installed on the heat medium supply pipeline to the water heater.
 - Setting supply and extract fan speed.
 - Filter clogging control and indication by operating hours.
 - Controlling supply and exhaust air dampers (to be ordered separately).

■ Mounting

- Mounting to floor, ceiling or wall with fixing brackets.
- The correct mounted unit must provide condensate collecting and

drainage and free access to the hinged side panels for servicing and filter replacement.

■ Technical data

Parameters	KOMFORT EC LW300-2	KOMFORT EC L1W300-2	KOMFORT EC LW400-2	KOMFORT EC LW550-2
Voltage [V / 50-60 Hz]	1 ~ 230			
Number of water (glycol) coil rows	2			
Power [kW]	0.14		0.35	
Current [A]	1.2		2.6	
Maximum air capacity [m³/h]	300		400	550
RPM	1380		1340	2150
Sound pressure level at 3 m [dBA]	24-45		28-47	
Transported air temperature [°C]	-25 up to +60			
Casing material	aluzinc			
Insulation	25 mm mineral wool			
Extract filter	cassette G4			
Supply filter	cassette F7			
Connected air duct diameter [mm]	150	160	200	
Weight [kg]	40			
Heat recovery efficiency [%]*	up to 90			
Heat exchanger type	counter-flow			
SEC class	A+			A
Heat exchanger material	polystyrene			

* Heat recovery efficiency is specified in compliance with the EN308 EU norms.

■ Overall dimensions

Model	Dimensions [mm]										
	ØD	B	B1	B2	B3	H	H2	H3	L	L1	L2
KOMFORT EC LW300-2	149	500	403	161	249	555	127	231	1092	1137	1198
KOMFORT EC L1W300-2	159	500	403	161	249	555	127	231	1092	1137	1198
KOMFORT EC LW400-2	199	500	403	161	249	555	127	231	1092	1137	1198
KOMFORT EC LW550-2	199	500	403	161	249	555	127	231	1092	1137	1198

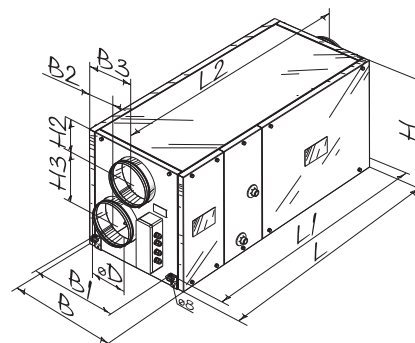

■ Accessories

Model	Replaceable filter G4 (cassette type)	Replaceable filter F7 (cassette type)
KOMFORT EC LW300-2	FP-EC LW300-550 G4	FP-EC LW300-550 F7
KOMFORT EC L1W300-2		
KOMFORT EC LW400-2		
KOMFORT EC LW550-2		

Technical data

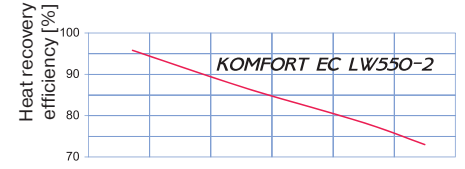
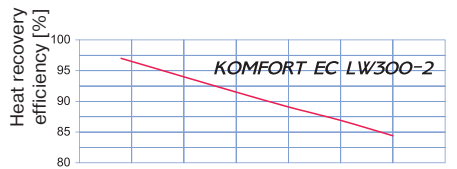
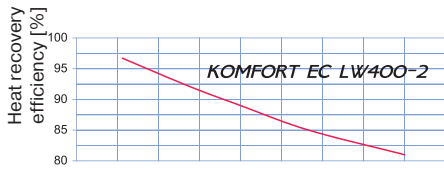
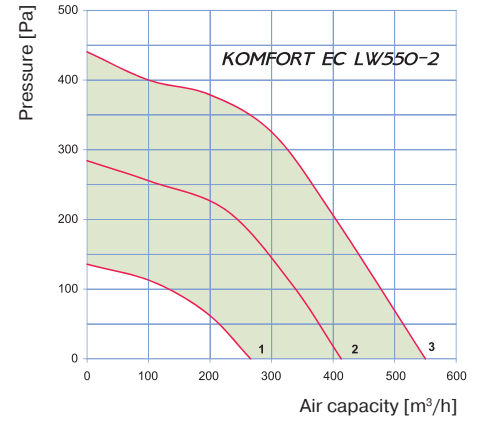
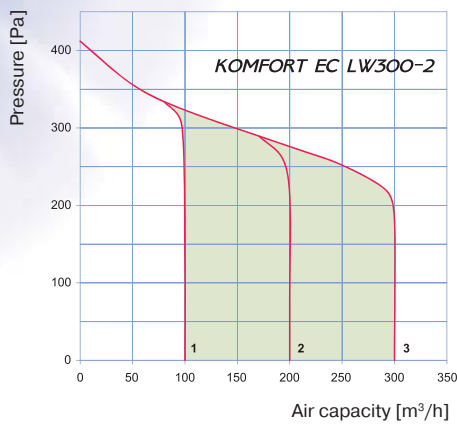
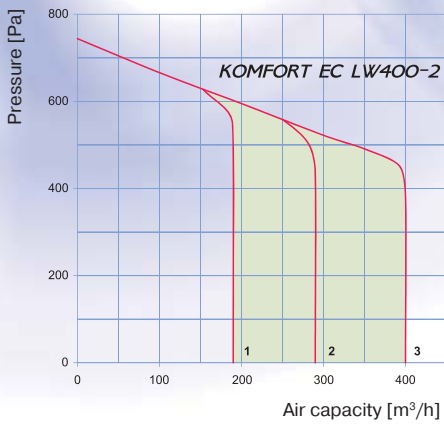

Hot water coil calculation diagram

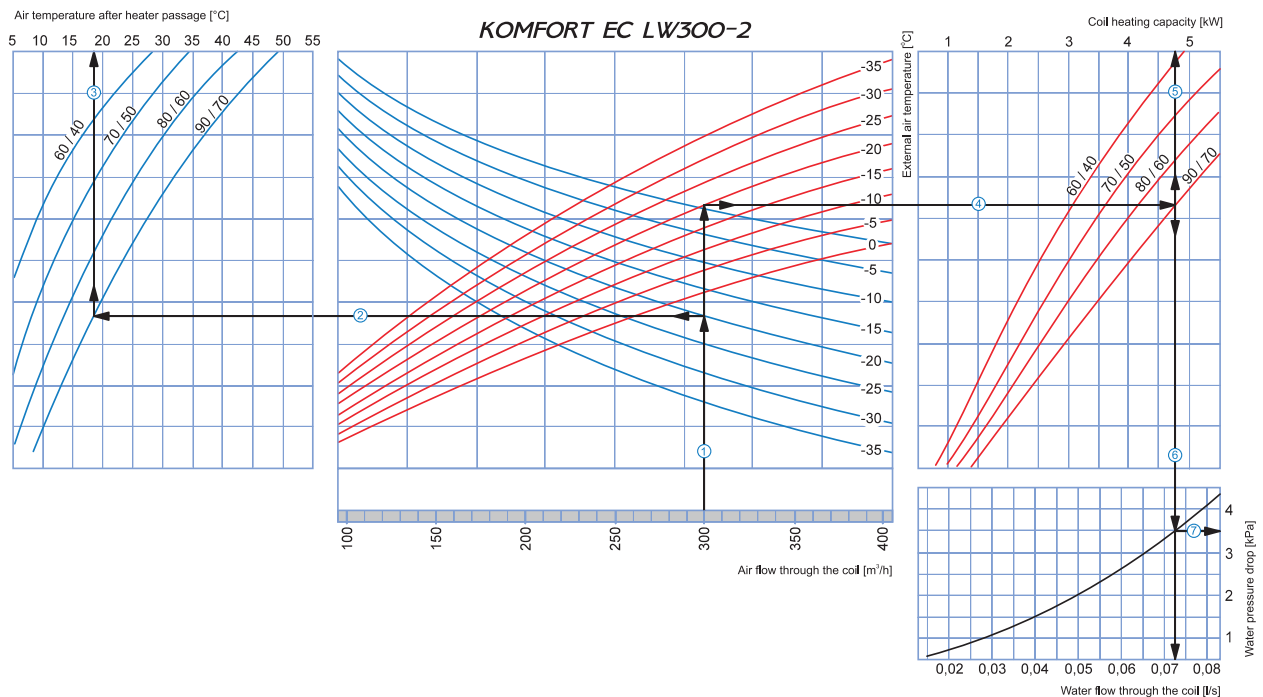

How to use water heater diagrams

Sample parameters: Air flow = 300 m³/h. Outside air temperature = -20°C. Water temperature (in/out) = 90/70 °C.

- **Supply air temperature:** prolong the line of air flow (e.g. 300 m³/h) ① up to the point where it crosses the outside air temperature (blue curve, e.g. -20°C); then draw a horizontal line ② from this point to the left until it crosses the water in/out temperature curve (e.g. 90/70 °C). From this point draw a vertical line ③ to the supply air temperature axis on top of the graphic (+18°C).
- **Heating coil capacity:** Prolong the line ① up to the point where it crosses the outside air temperature (e.g. -20°C, red curve) and draw a horizontal line ④ from this point to the right until it crosses the water in/out temperature curve (e.g., 90/70 °C). From here draw a vertical line ⑤ up to the scale representing the heating coil capacity (4.75 kW).
- **Water flow:** Prolong the line ⑤ down to the water flow axis ⑥ at the bottom of the graphic (0.072 l/s).
- **Water pressure drop:** Draw the line ⑦ from the point where the line ⑥ crosses the black curve to the pressure drop axis (3.5 kPa).

Hot water coil calculation diagram

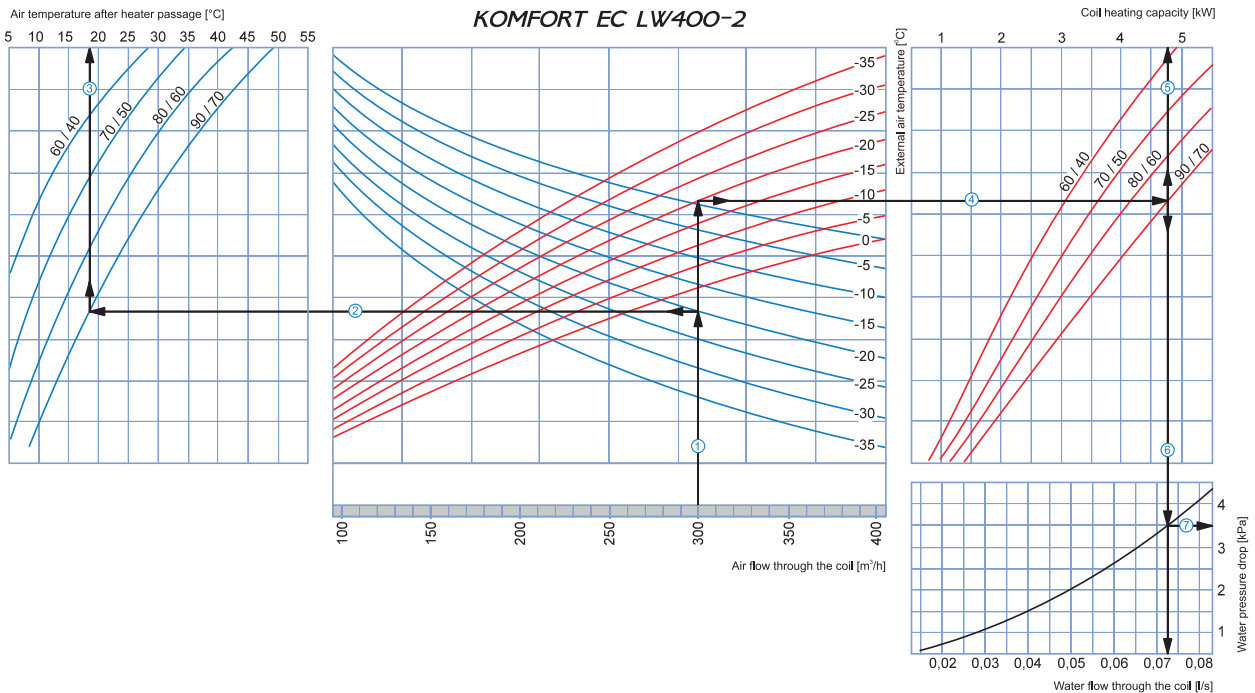

How to use water heater diagrams

Sample parameters: Air flow = 300 m³/h. Outside air temperature = -20°C. Water temperature (in/out) = 90/70 °C.

- **Supply air temperature:** prolong the line of air flow (e.g. 300 m³/h) ① up to the point where it crosses the outside air temperature (blue curve, e.g. -20°C); then draw a horizontal line ② from this point to the left until it crosses the water in/out temperature curve (e.g. 90/70 °C). From this point draw a vertical line ③ to the supply air temperature axis on top of the graphic (+18°C).
- **Heating coil capacity:** Prolong the line ① up to the point where it crosses the outside air temperature (e.g. -20°C, red curve) and draw a horizontal line ④ from this point to the right until it crosses the water in/out temperature curve (e.g., 90/70 °C). From here draw a vertical line ⑤ up to the scale representing the heating coil capacity (4.75 kW).
- **Water flow:** Prolong the line ⑤ down to the water flow axis ⑥ at the bottom of the graphic (0.072 l/s).
- **Water pressure drop:** Draw the line ⑦ from the point where the line ⑥ crosses the black curve to the pressure drop axis (3.5 kPa).

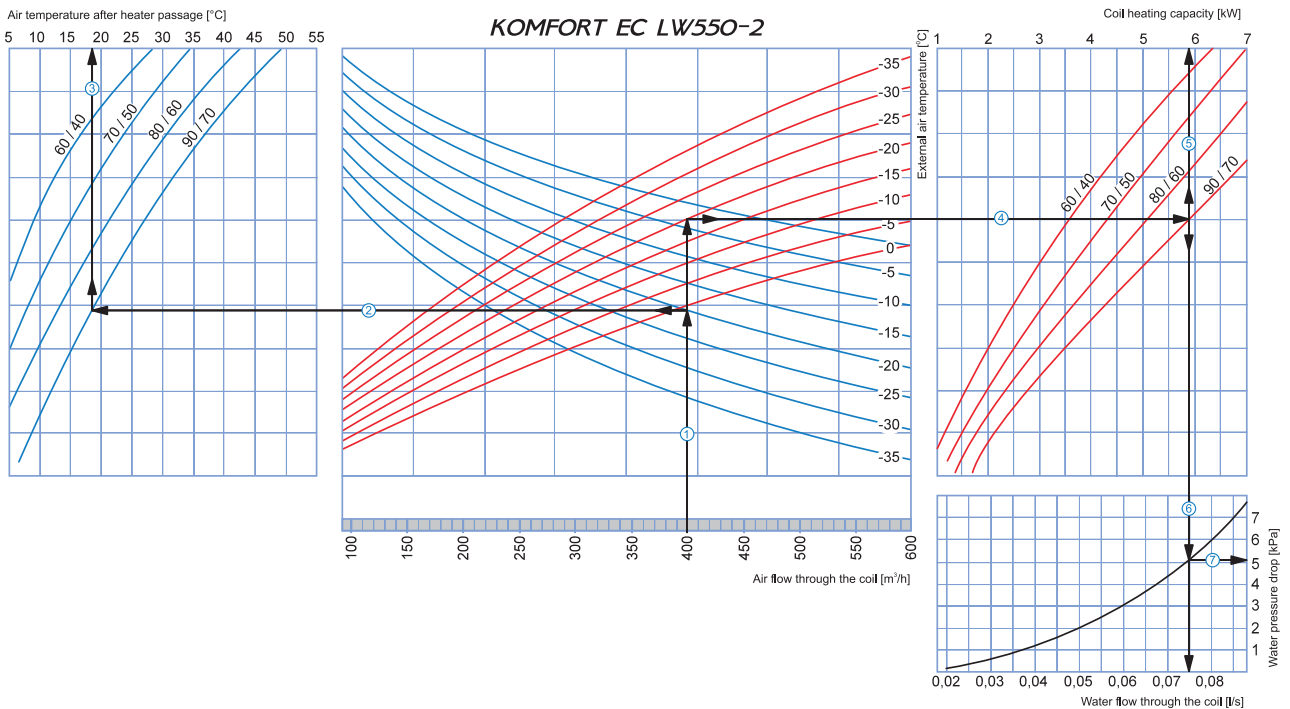

How to use water heater diagrams

Sample parameters: Air flow = 400 m³/h. Outside air temperature = -20°C. Water temperature (in/out) = 90/70 °C.

- **Supply air temperature:** prolong the line of air flow (e.g. 400 m³/h) ① up to the point where it crosses the outside air temperature (blue curve, e.g. -20°C); then draw a horizontal line ② from this point to the left until it crosses the water in/out temperature curve (e.g. 90/70 °C). From this point draw a vertical line ③ to the supply air temperature axis on top of the graphic (+18°C).
- **Heating coil capacity:** Prolong the line ① up to the point where it crosses the outside air temperature (e.g. -20°C, red curve) and draw a horizontal line ④ from this point to the right until it crosses the water in/out temperature curve (e.g., 90/70 °C). From here draw a vertical line ⑤ up to the scale representing the heating coil capacity (5.9 kW).
- **Water flow:** Prolong the line ⑤ down to the water flow axis ⑥ at the bottom of the graphic (0.075 l/s).
- **Water pressure drop:** Draw the line ⑦ from the point where the line ⑥ crosses the black curve to the pressure drop axis (5.1 kPa).