



Wall-mounted heat recovery air handling units

KOMFORT EC U330 KOMFORT EC UE330-2

Air capacity – up to 331 m³/h

Heat recovery efficiency – up to 98 %



Application

- ❑ Air handling units for efficient supply and exhaust ventilation in flats, houses, cottages and other buildings.
- ❑ Heat recovery minimises ventilation heat losses.
- ❑ Controllable air exchange for creating the best suitable indoor microclimate.
- ❑ Compatible with round Ø150 mm air ducts.

Design

- ❑ The casing is made of polymer coated steel panels, internally filled with mineral wool layer of 20 mm for heat and sound insulation.
- ❑ The included fixing bracket facilitates the unit wall mounting.
- ❑ The hinged panel of the casing ensures easy access to the internals for cleaning and other maintenance operations.
- ❑ The spigots for connection to the air ducts are located at the angle and are rubber sealed for airtight connection to the air ducts.

Fans

- ❑ High-efficient external rotor EC motors and centrifugal impellers with backward curved blades for air supply and exhaust.
- ❑ EC motors have the best power consumption to air capacity ratio and meet the latest demands concerning energy saving and high-efficient ventilation.
- ❑ EC motors are featured with high performance, low noise level and totally controllable speed range.
- ❑ Dynamically balanced impellers.

Heat recovery

- ❑ The unit is equipped with a plate counter-flow polystyrene heat exchanger with a large surface area and high heat recovery efficiency.
- ❑ Heat recovery is based on the utilization of the thermal energy of the extract air for heating up supply air. Extract air transfers most of its heat to the intake air flow. Heat recovery reduces heat losses in cold seasons.
- ❑ In summer the heat exchanger performs reverse and intake air is cooled in the heat exchanger by the cool extract air. This contributes to better performance of the air conditioner in ventilated premises.
- ❑ The drain pan under the heat exchanger block is used for condensate collection. The drain pan is fitted with a drain pipe for condensate removal.
- ❑ The electronic freeze protection system is used to prevent the heat exchanger freezing in the cold season:
 - **KOMFORT EC UE330-2**: if air temperature in the intake air duct falls down below -7 °C, the bypass damper is opened periodically for 5 minutes to let intake air flow along the bypass air duct. Synchronously, the heat exchanger surface is warmed up with warm extract air flow.
 - **KOMFORT EC U330**: in case of a freezing danger registered by the temperature sensor the supply fan turns off to let the heat exchanger surface get warmed up with warm extract air flow. After that the the supply fan is turned on and the unit reverts to the standard operation mode.

Air heater

- ❑ The **KOMFORT EC UE330-2** model includes an electric heater for operation at low outside air temperatures.
- ❑ The built-in electric heater is activated to warm up supply air flow if set indoor air temperature may not be reached by means of heat recovery only.
- ❑ The electric heater has a reliable overheating protection.

Air filtration

- ❑ Two built-in G4 cassette filters provide efficient supply and extract air filtration.

Control and automation

- ❑ The unit incorporates an integrated control system, a wall-mounted control panel with an LCD display and a remote control.
- ❑ The standard delivery set includes a 10 m cable for connection of the unit and the control panel.
- ❑ Automation functions:
 - Activating/deactivating the unit.
 - Setting low, medium and high speeds for the supply and extract fan. Air flow control. Each speed is individually set up during adjustment.
 - Heater turning on/off and supply air temperature setting for **KOMFORT EC UE330-2**.
 - Timer turning on/off and adjusting timer operation.
 - Enabling/disabling heat recovery operation mode by means of manual opening/closing the bypass damper.
 - Indication of basic parameters and operation modes on the wall-mounted panel as indoor temperature, time, etc.
 - Failure indication and filter replacement indication by motor meter.
 - Date/time setting.
 - Setting week-scheduled operation of the unit.
 - Reliable heat exchanger freezing protection and heater overheating protection.

Mounting

- ❑ The unit is designed for wall mounting.
- ❑ The filters are accessible through the front panel.
- ❑ The delivery set includes a special wall-mounted fixing bracket and anchor bolts for simple and comfortable mounting.
- ❑ The mounting place must provide enough space for connection to drain system and condensate drainage.

Technical data

Parameters	KOMFORT EC U330			KOMFORT EC UE330-2		
	1	2	3	1	2	3
Speed	1	2	3	1	2	3
Voltage [V / 50-60 Hz]	1 ~ 230					
Fan power [W]	36	138	220	36	138	220
Fan current [A]	0.29	0.97	1.48	0.29	0.97	1.48
Electric heater power [kW]	-			2.0		
Electric heater current [A]	-			8.72		
Total unit power [kW]	0.22			2.22		
Total unit current [A]	1.5			10.2		
Maximum air capacity [m³/h]	133	270	331	133	270	331
RPM	1440	2200	2900	1440	2200	2900
Sound pressure level at 3 m [dBA]	28	34	41	28	34	41
Transported air temperature [°C]	-25 up to +60					
Casing material	polymer coated steel					
Insulation	20 mm mineral wool					
Extract / supply filter	cassette G4					
Connected air duct diameter [mm]	150					
Weight [kg]	43			44		
Heat recovery efficiency [%]*	83 up to 98					
Heat exchanger type	counter-flow					
SEC class	A					
Heat exchanger material	polystyrene					

* Heat recovery efficiency is specified in compliance with the EN308 EU norms.

Overall dimensions, mm

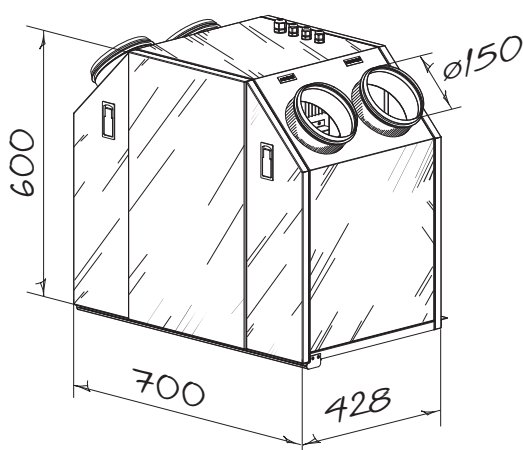

Accessories

Model	Replaceable filter G4 (cassette)
KOMFORT EC U330	FP-EC UE330 G4
KOMFORT EC UE330-2	

