

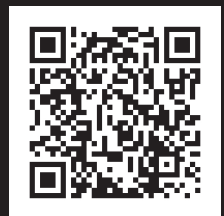

HEAT RECOVERY AIR HANDLING UNIT



KOMFORT Ultra D105



EN

OPERATION MANUAL

CONTENTS

3	Introduction
3	General
3	Safety rules
3	Transportation and storage rules
3	Manufacturer's warranty
4	Technical data
4	Operating logic
4	Delivery set
5	Technical data
6	Mounting
7	Connection to power mains
8	Unit control
9	Maintenance
10	Troubleshooting and fault handling
11	Acceptance certificate
11	Connection certificate
11	Warranty card

BLAUBERG Ventilatoren GmbH company is happy to offer your attention a compact heat recovery air handling unit **KOMFORT Ultra D105**.

INTRODUCTION

The present operation manual contains a technical description, technical data sheets, operation and mounting guidelines, safety precautions and warnings for safe and correct operation of the unit. Read carefully and understand the operation manual, especially the safety requirements, before the unit mounting and start up. Keep the operation manual available as long as you use the unit.

GENERAL

The KOMFORT Ultra D105 heat recovery air handling unit is designed for efficient and energy saving ventilation of domestic and public premises.

The unit is not a ready to use product but a component part of central air conditioning and ventilation network. The unit is designed for suspended mounting. The unit is available for round Ø 125 mm air ducts.

The unit is rated for indoor application at ambient temperature from +1 °C up to +40 °C and relative humidity not exceeding 80 %. The transported air temperature is allowed from -25 °C up to +50 °C.

Hazardous parts access and water ingress protection rating:

- unit motors – IP44;
- assembled unit connected to air ducts – IP22.

The unit design is regularly improved, so some models can slightly differ from those ones described in this service instruction.

SAFETY RULES

All operations related to the unit electrical connections, servicing and repair works are allowed only after the unit disconnection from power mains.

The unit is rated as a Class I electrical appliance.

All mounting and servicing operations are allowed by duly qualified personnel.

Please follow the safety regulations and working instructions (DIN EN 50 110, IEC 364).

Make sure the impeller and the casing are not damaged before connecting the unit to power mains. The casing internals must be free of any foreign objects which can damage the impeller blades or motor.

The unit maintenance and repair is allowed only after power cut-off and full stop of the rotating parts.

Misuse of the unit or any unauthorized modification are not allowed.

The unit is designed for connection to ac single-phase power mains, see „Technical Data“.

The unit is rated for permanent operation.

Take steps to prevent ingress of smoke, carbon monoxide and other combustion products into the room through open chimney flues or other fire-protection devices. Sufficient air supply must be provided for proper combustion and exhaust of gases through the chimney of fuel burning

equipment to prevent back drafting. The minimal permitted pressure difference per living units is 4 Pa.

The transported air must not contain any dust or other solid impurities, sticky substances or fibrous materials.

The unit is not rated for operation in a flammable or explosive medium.

Fulfil the operation manual requirements to ensure a trouble-free and long service life of the unit.

TRANSPORTATION AND STORAGE RULES

Transportation of the unit is allowed by any type of vehicle provided the unit is protected against weather and mechanical damages.

Use hoist machinery for handling to prevent possible mechanical damages of the unit. Fulfil the requirements of transportation for this cargo type.

Store the unit in a dry and cool place in the original packing. The storage environment must not be subjected to any aggressive and/or chemical evaporations, admixtures, foreign objects that may provoke corrosion and damage connection tightness.

Store the unit in an environment with minimized risk of mechanical damages, temperature and humidity fluctuations. Do not expose the unit to the temperatures below +5 °C and above +40 °C .

Connection of the unit to power mains is allowed after the unit has been kept indoor for minimum two hours.

MANUFACTURER'S WARRANTY

The unit complies with the requirements according to the EU norms and directives, to the relevant EU-Low Voltage Equipment Directives, EU-Directives on Electromagnetic Compatibility.

We hereby declare that the unit complies with the essential protection requirements of Electromagnetic Council Directive 2004/108/EC, 89/336/EEC and Low Voltage Directive 2006/95/EC, 73/23/EEC and CE-marking Directive 93/68/EEC on the approximation of the laws of the Member States relating to electromagnetic compatibility. This certificate is issued following test carried out on samples of the product referred to above. Assessment of compliance of the product with the requirements relating to electromagnetic compatibility was based on the referred standards.

The manufacturer hereby warrants normal operation of the unit over the period of two years from the retail sale date provided observance of the installation and operation regulations.

In case of failure due to manufacturing fault during the warranty period the consumer has the right to repair or to exchange it.

The replacement is offered by the Seller.

If case of no confirmation of the sale date, the warranty period shall be calculated from the manufacturing date.

The Manufacturer shall not be liable for any damage resulting from any misuse of or gross mechanical interference with the unit.

The manufacturer is not responsible for the damages resulted due to the use of third party equipment or to third party equipment.



WARNING

The unit is not allowed for use by children and persons with reduced physical, mental or sensory capacities, without proper practical experience or expertise, unless they are controlled or instructed on the product operation by the person(s) responsible for their safety. Supervise the children and do not let them play with the product.



WARNING

Do not dispose in domestic waste. The unit contains in part material that can be recycled and in part substances that should not end up as domestic waste. Dispose of the unit once it has reached the end of its working life according to the regulations valid in your country.

DESIGN

The compact casing is made of double-skinned aluzinc panels, internally filled with 15 mm PE foam film layer for heat- and soundinsulation. The casing has mounting angles for easy installation. The hinged side panel ensures easy access to the internals for cleaning and other maintenance operations. The spigots for connection to the air ducts are located at the side of the unit and are rubber sealed for airtight connection to the air ducts. The supply and exhaust spigots are equipped with backdraft dampers.

Asynchronous motors are used for air supply and exhaust. The centrifugal impeller with forward curved blades ensures high pressure and low noise

level. The motors are equipped with integrated overheating protection and ball bearings for a longer service life.

The enthalpy cross-flow heat exchanger made of polymerized cellulose is used for heat recovery. This heat exchanger type is used for both extract air sensible and latent heat recovery. The heat exchanger is frostproof and generates no condensate. The units with enthalpy heat exchangers are recommended for operation in air conditioned premises.

Two built-in panel filters with filtering class G4 provide efficient supply and extract air filtration.

Air flow control is performed with the CDP-3/5 external speed switch.

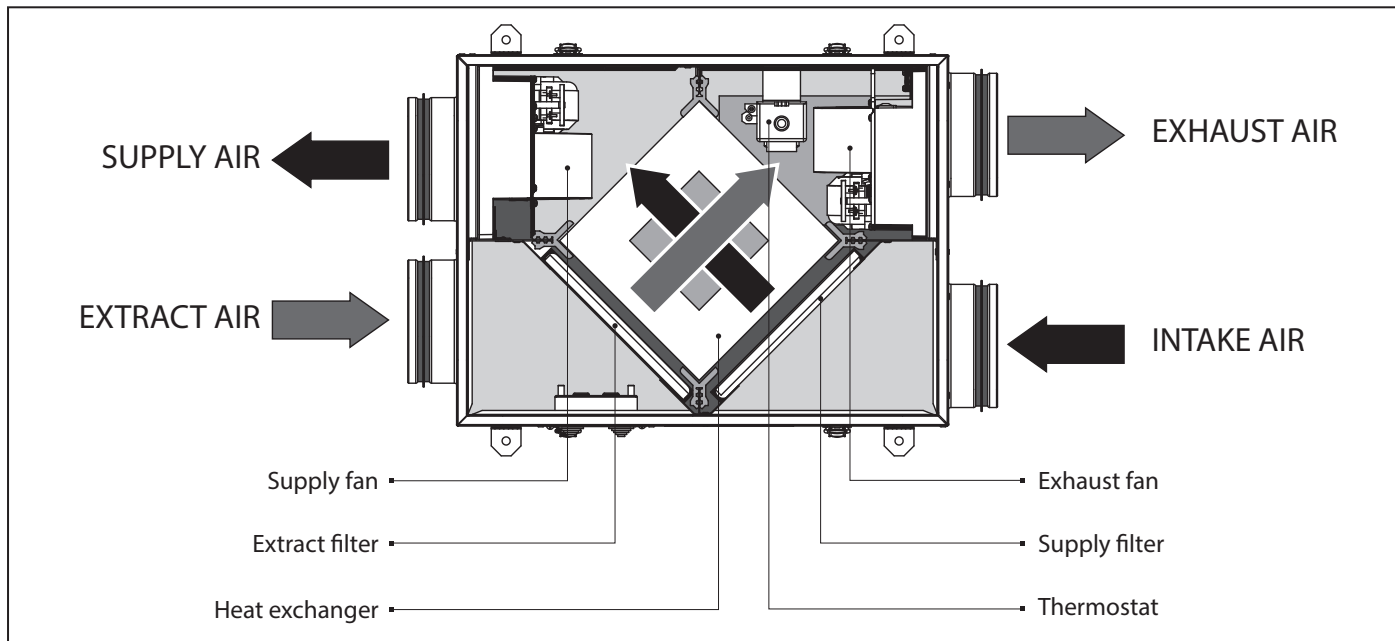

Fig. 1. Unit design and operating logic.

OPERATING LOGIC

Clean cold air from outside flows to the heat exchanger, where from it is moved to the room with the supply fan.

Warm stale air is extracted from the room with the exhaust fan and is moved through the air ducts to the heat exchanger, where it transfers its heat energy to the intake air. After that it is exhausted outside.

Heat recovery minimizes heat losses caused by traditional window ventilation and saves energy.

In summer the heat exchanger performs reverse and transfers cold air from

the cooled extract air for warming up intake air. This contributes to better performance of the air conditioner in ventilated premises.

The freeze protection thermostat is installed in the exhaust air duct to prevent heat exchanger icing. In case of a freezing danger the thermostat turns the supply fan off to let the heat exchanger get warmed with warm extract air flow. Turn the thermostat control knob in a required position to set a temperature set point.

The factory temperature setting is +3 °C.

DELIVERY SET

- ✓ Air handling unit – 1 item;
- ✓ Operation manual – 1 item;
- ✓ Speed switch – 1 item;
- ✓ Packing – 1 item.



WARNING

Make sure the unit has no visible transport damages while accepting the goods. Check the ordered and the delivered goods for compliance.

TECHNICAL DATA

Table 1. Technical data

Parameters	KOMFORT Ultra D105		
	I	II	III
Speed			
Unit voltage [V / 50 Hz]	1~ 230		
Unit power [W]	30	38	56
Unit current [A]	0.18	0.23	0.34
Max. air capacity [m ³ /h]	57	78	106
RPM	1300	1950	2500
Sound pressure level at 3 m distance [dBA]	24	32	41
Transported air temperature [°C]	-25 up to +50		
Casing material	Aluzinc		
Insulation	15 mm, PE foam film		
Filter: extract / supply	panel G4		
Replaceable filter*	FP-Ultra D105		
Connected air duct diameter [mm]	125		
Weight [kg]	10		
Heat recovery efficiency [%]	65 up to 76		
Humidity recovery efficiency [%]	up to 65		
Heat exchanger type	cross-flow		
Heat exchanger material	polymerised cellulose		

* extra replaceable filters are special accessories and available on a separate order.

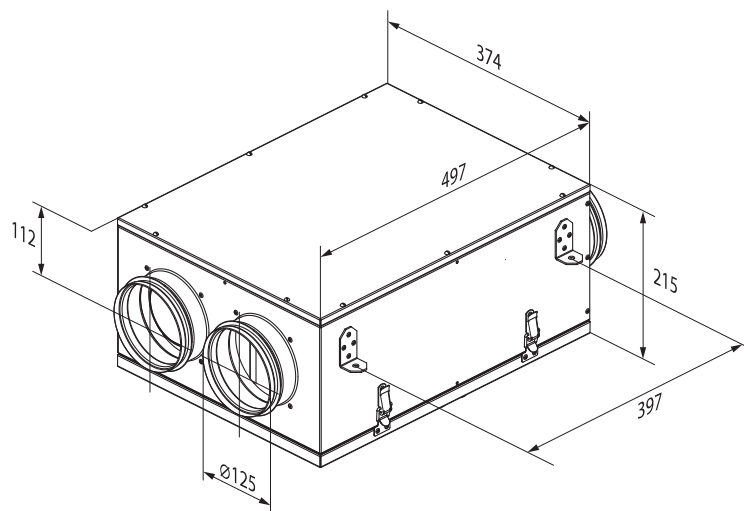
Fig. 2. Overall dimensions

MOUNTING

Due to the compact casing size the unit is designed for horizontal mounting behind false ceiling and connection to \varnothing 125 mm air ducts.

The unit is suitable for mounting in engineering and service premises as well as living and lounge areas.

While planning the ductwork layout avoid too long air duct sections, numerous bends and reducers because it may reduce air flow.

The mounted air ducts must not be deformed.

Provide airtight connection of the air ducts to the unit spigots and fittings.

The minimum distance between the unit and a surface is shown in Fig. 3.

The unit is suspended to the ceiling using a threaded rod fixed inside of a threaded dowel.

The unit mounting position must provide access to the terminal box for electric connection and access to the detachable service panel for maintenance and filter replacement.

While mounting the unit install a ventilation grille, an outer hood, a disk valve or any other protecting device at outlet from the air duct with a mesh width not exceeding 12.5 mm.

**WARNING****Safety precautions:**

The unit must be mounted to a rigid and stable structure construction.

The unit must be suspended using anchor bolts. Before starting mounting check that the mounting construction has sufficient loading capacity for the unit weight, otherwise reinforce it with beams, etc.

If the fixing rods used for the unit fixation are too short it may result in resonating with ceiling. To prevent a possible resonance problem use fixing rods with a sufficient length.

If the spiral air duct connection point is supposed to be the source of noise generation replace the spiral air duct with a flexible one. The flexible connectors are also recommended for noise absorption.

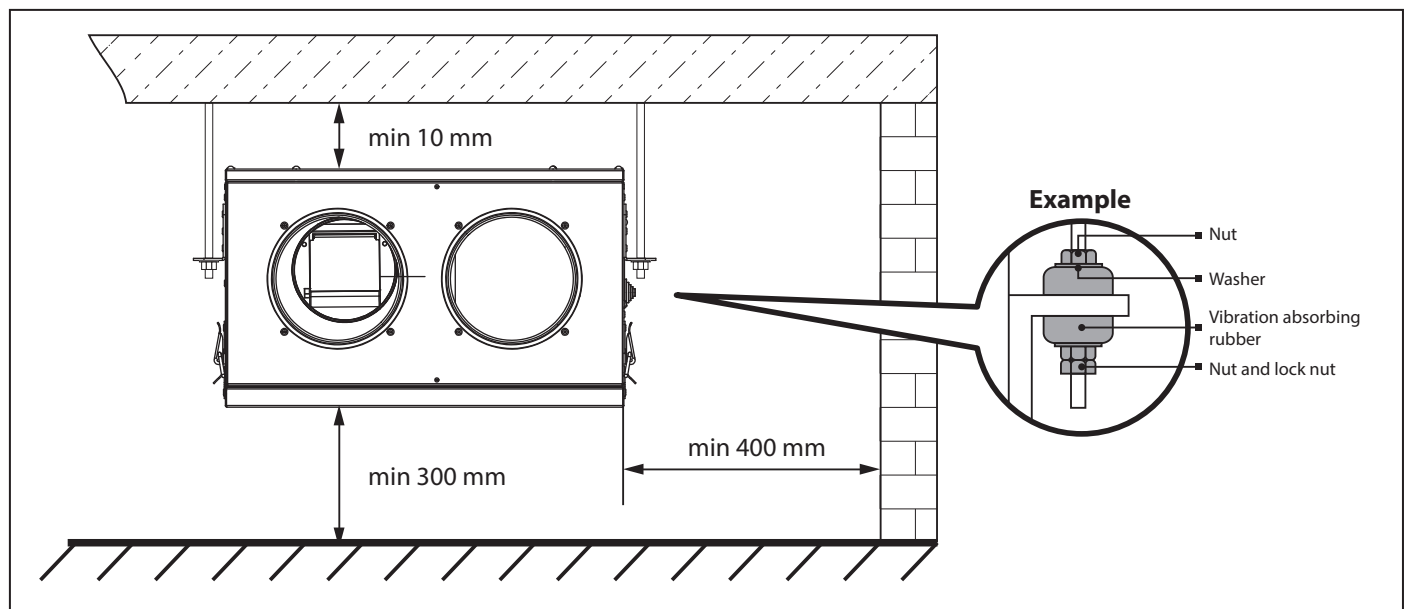

Fig. 3. Unit mounting

CONNECTION TO POWER MAINS



WARNING

Read the operation manual prior to any electric installations. Connection of the unit to power mains is allowed by a qualified electrician only.

The rated electrical parameter are stated on the rating plate. No modifications of internal connections are allowed and will result in void warranty.

Connect the unit only to power mains with valid electric standards.

Follow the respective electric standards, safety rules (DIN VDE 0100), TAB der EVUs. The house cabling system must be equipped with an automatic switch at the external input. Connect the unit to power mains through the automatic switch. The contact gap on all poles at least 3 mm (VDE 0700 T1 7.12.2 / EN 60335-1).

The automatic switch trip current must be not below the rated current consumption, refer Table 1. Install the automatic switch to ensure prompt access to it.

The unit is rated for connection to single-phase alternating current power mains 230 V / 50 Hz.

The unit is delivered ready to plug-in and is connected to power supply via a pre-wired power cable with a euro plug.

In case of need to connect a longer cable follow the wiring diagram below.

The electric connections must be performed with insulated, durable and heat-resistant cables, wires with a matching cross section, in any case not below 0.75 mm².

The referred conductor cross section is for reference only.

While selecting the conductors with respective cross section consider the wire type, the maximum permissible conductor heating temperature, its insulation, length and layout.

Use copper wires only! The unit must be grounded in compliance with the valid electrical standards of the user country!

Connect the unit to power mains through the terminal block located in the terminal box on the unit casing following the wiring diagram and the terminal designation, Fig. 4.

Connect all the control and power conductors in compliance with the terminal marking and polarity. The rating plate with a terminal designation is placed inside of the terminal box. The terminal clamp marking corresponds to the marking on the wiring diagram.

Route the conductors to the terminal box through the electric lead-in on the unit panel to preserve the electrical protection class.

The fixed electrical wiring must be equipped with a thermal magnetic automatic switch that is used for connection of the unit to power mains.

The automatic switch trip current must be not below the rated current consumption (min. 1 A).

Cut power supply to the unit off by turning the automatic electric switch QF to OFF position prior to any operations.

Take steps to prevent activation of the automatic switch.

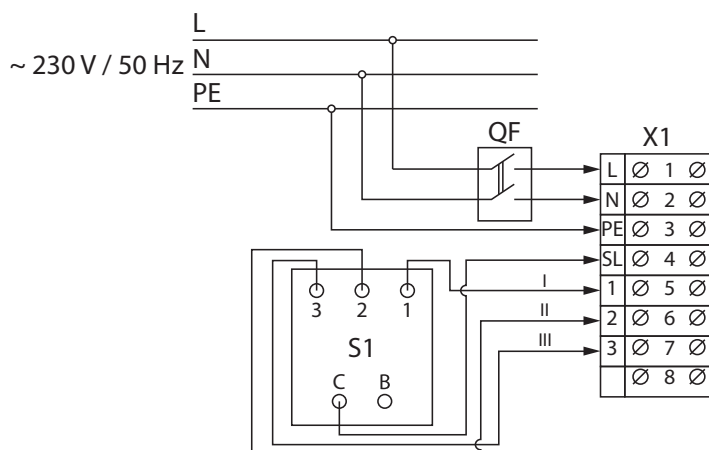
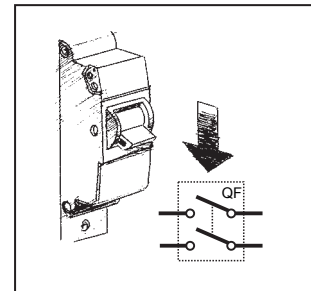

QF – automatic switch (not included into the delivery set).

S1 – CDP-3/5 speed switch.

X1 – terminal block.

Fig. 4. Wiring diagram

UNIT CONTROL

The unit air flow has 3-step control performed with the CDP-3/5 speed switch. Set the speed switch control knob to a required position to activate

a required unit speed, Fig. 5. Install the speed switch in any place that allows comfortable controlling.

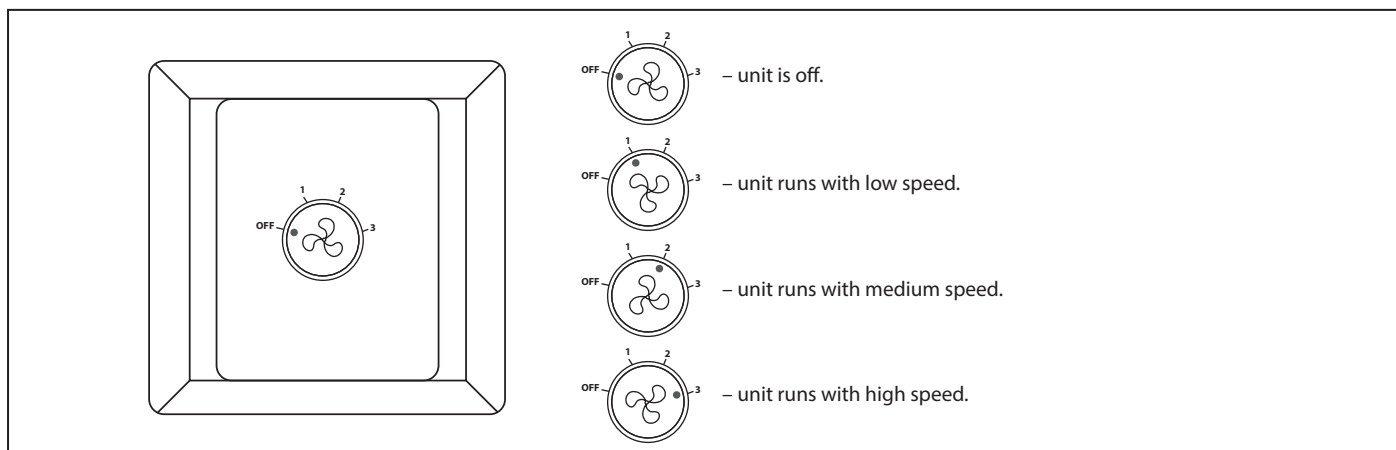

Fig. 5. CDP-3/5 speed switch

TECHNICAL MAINTENANCE



WARNING

Cut power supply to the unit off by turning the automatic electric switch QF to OFF position prior to any maintenance operations. Take steps to prevent re-activation of the automatic switch.

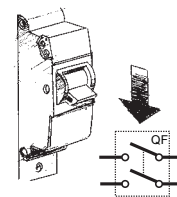

Regular technical supervision and maintenance of the unit are required to ensure the product long service life and non-stop operation. Disconnect the unit from power mains prior to any maintenance operations.

Warning! Consider the unit sharp edges! Fulfill maintenance operations in work gloves!

Fulfil the unit maintenance 3–4 times per year.

The unit technical maintenance includes regular cleaning of the unit and other works:

1. Filter maintenance (3–4 times per year).

Dirty filters increase air resistance and decrease supply air. Clean the filter with a vacuum cleaner or flush it with water. After two consecutive cleanings the filter must be replaced. Install dry filters only! To buy a new filter contact a local distributor for the filters stated above in the section „Technical data“.

Dirty filters are not considered as a warranty case!

Replace immediately humid and mouldy filters!

Filter should be removed as follows:

- Make sure the unit is disconnected from power mains.
- Undo the latches and open a swivel panel.
- Remove the dirty filters from the unit and insert new or cleaned filters.

2. Heat exchanger maintenance (once per year).

The heat exchanger must be regularly cleaned to maintain high heat exchanger efficiency even in case of the regular filter cleaning.

To clean the polymerized cellulose heat exchanger applied in KOMFORT Ultra D105 remove it from the unit and clean it with a vacuum cleaner. Do not use water, abrasive detergents, solvents, sharp objects not to avoid the heat exchanger. Install the heat exchanger into the unit after cleaning.

Heat exchanger removal is as follows:

- Make sure the unit is disconnected from power mains.
- Unlatch and open the service panel.
- Remove the service panel.

- Turn and loosen the retaining support and remove the soiled heat exchanger.
- Clean the heat exchanger.
- Re-install the clean and dry heat exchanger back to the unit.

3. Fan maintenance (once per year).

The regular filter cleaning may not completely prevent the dust ingress into the unit, which results in the unit capacity decrease.

Clean the fan with a soft cloth or a brush.

Cleaning with water, abrasive detergents, sharp object or chemicals is not allowed.

4. Supply air flow control (twice per year).

Check the supply grille and remove foreign objects to maintain free air intake.

5. Air ducts maintenance (once in 5 years).

The regular unit maintenance in compliance with the above rules may not completely prevent dust ingress into the air ducts which may result in air flow decrease. The air duct maintenance consist in periodical cleaning or replacement.

6. Exhaust grilles and intake diffuser maintenance (as required).

Remove the exhaust grille and the intake diffuser and flush those with warm detergent solution. Check the ductworks thread connections periodically.

TROUBLESHOOTING AND FAULT HANDLING

Table 2. Fault list and fault handling

Fault	Possible reason	Fault handling
The fan does not start with turning on the unit	No power supply or wrong connection to power mains.	Connect the unit to power mains. Troubleshoot a connection error.
	Jammed motor, soiled impeller blades.	Remove the motor jam, clean the impeller blades.
Automatic switch tripping	Short circuit in power grid.	Turn the unit off and contact the unit Seller for troubleshooting.
Low air flow	Too low set speed.	Set higher speed.
	The filters and the fans are soiled, the heat exchanger is soiled.	Clean or replace the filters, fans and heat exchanger.
	The air dampers, the supply diffusers or the exhaust grilles are closed or soiled.	Remove and clean the air dampers, the supply diffusers, the exhaust grilles to ensure free air flow.
	The speed switch is defective.	Turn the unit off and contact the unit Seller for troubleshooting.
Low supply air temperature	The extract filter is soiled.	Clean or replace the extract filter.
	The heat exchanger is iced.	Check the heat exchanger condition. Shutdown the unit if required and turn it on after a freezing danger is no longer imminent.
Noise, vibration	The impeller is soiled.	Clean the impeller.
	The screw connection is loose.	Tighten the screws.
	No flexible anti-vibration connectors.	Install the flexible anti-vibration connectors.

ACCEPTANCE CERTIFICATE**Heat recovery air handling unit**

KOMFORT Ultra D105

is recognized as serviceable.

The unit complies with the requirements according to the EU norms and directives, to the relevant EU-Low Voltage Equipment Directives, EU-Directives on Electromagnetic Compatibility. We hereby declare that the following product complies with the essential protection requirements of Electromagnetic Council Directive 2004/108/EC, 89/336/EEC and Low Voltage Directive 2006/95/EC, 73/23/EEC and CE-marking Directive 93/68/EEC on the approximation of the laws of the Member States relating to electromagnetic compatibility.

This certificate is issued following test carried out on samples of the product referred to above.

Approval mark _____ Manufacturing date _____

CONNECTION CERTIFICATE**Heat recovery air handling unit**

KOMFORT Ultra D105

is connected to power mains in compliance with the operation manual requirements by the professional:

Company _____

Name: _____

Date _____ Signature _____

WARRANTY CARD

KOMFORT Ultra D105

SELLER**SALES DATE****REPRESENTATIVE IN EU**

BLAUBERG Ventilatoren GmbH
Aidenbachstr. 52
D-81379 Munich,
Germany



BLAUBERG
Ventilatoren



www.blaubebergventilatoren.de
Komfort_Ultra_D105_v.2(1)_EN