

RENEO-FIT D 100 S14

Heat and energy recovery air handling units

Features

- Air handling units for efficient supply and exhaust ventilation in flats and apartments.
- Heat recovery minimizes ventilation heat losses during cold season and reduce air conditioner load during hot season.
- Controllable air exchange for creating the best suitable indoor microclimate.



Air flow:
up to 136 m³/h
38 l/s



Heat recovery efficiency:
up to 94 %



Design

- The casing is made of expanded polypropylene (EPP) with high heat- and sound-insulating properties.

Fans

- High-efficient external rotor EC motors and centrifugal impellers with forward curved blades are used for air supply and exhaust.

Air filtration

- Two built-in G4 and F7 filters provide efficient supply air filtration.
- The G4 filter is used for extract air filtration.

Heat recovery

- The **Reneo-Fit D 100** unit is equipped with a counter-flow polysterene heat exchanger for heat recovery. The unit condensate is collected and drained to the drain pan under the heat exchanger.



- The **Reneo-Fit D 100-E** unit is equipped with an enthalpy counter-flow heat exchanger for heat and humidity recovery.



Mounting

- The units are designed for suspended ceiling mounting.
- Service access for maintenance and filter replacement must be provided.

Control and automation

- **Reneo-Fit D 100 S14** units are equipped with an integrated automation system and an S14 wall-mounted control panel with LED-indication.

Automation functions

Functions	Description
Unit control via a remote wired control panel	S14 control panel 
Speed switch	+
Filter replacement indication	by filter timer
Alarm indication	LED indication about alarms
Freeze protection	using cyclical stops of the supply fan
Humidity control	option
CO ₂ control	option
Fire alarm sensor connection	option

Option: the functionality is available when purchasing the appropriate accessory (see the "Accessories" section)

Designation key

Series	Casing modification	Casing type	Heater	Nominal size	Modification	Heat exchanger type	Service side	Controller type
Reneo	- Fit: compact	D: suspended	_ : w/o heater	10: Nominal airflow	0: by default	- _ : heat recovery E: energy recovery	_ : universal	S14

Overall dimensions [mm]

Model	H	H1	L	L1	W
Reneo-Fit D 100(-E) S14	520	600	530	630	242

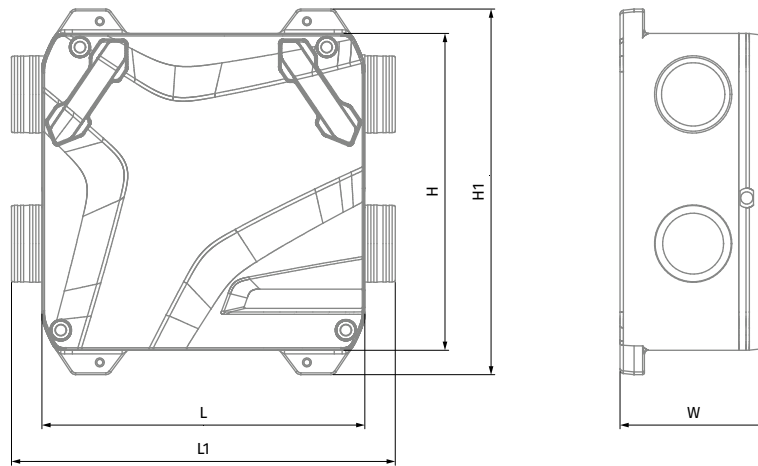

Technical data

Parameters	Reneo-Fit D 100	Reneo-Fit D 100-E
Voltage [V / 50 (60) Hz]	1~ 230	1~ 230
Power [W]	43	43
Current [A]	0.365	0.365
Maximum air flow [m³/h (l/s)]	136 (38)	136 (38)
Sound pressure level at 3 m [dBA]	30	30
Transported air temperature [°C]	-23...+40	-23...+40
Casing material	EPP	EPP
Insulation [mm]	25	25
Extract filter	G4 / Coarse >60 %	G4 / Coarse >60 %
Supply filter	G4 / Coarse >60 % (option: F7 / ePM1 60 %)	G4 / Coarse >60 % (option: F7 / ePM1 60 %)
Connected air duct diameter [mm]	125	125
Weight [kg]	8	8
Heat recovery efficiency [%]	80-94	70-93
Heat exchanger type	counter-flow	counter-flow
Heat exchanger material	polystyrene	enthalpy
SEC class	A+	A

Sound power level, A-weighted	Total	Octave frequency band [Hz]								LpA 3 m	LpA 1 m
		200	400	800	1000	2000	4000	8000	10000		
L _{WA} to supply outlet [dBA]	59	45	46	50	51	48	39	39	37	38	48
L _{WA} to exhaust inlet [dBA]	46	35	35	37	36	31	21	23	24	26	35
L _{WA} to environment [dBA]	50	36	39	41	40	37	32	26	25	30	39

Sound data provided for point 2 on the diagram.

Point	Air flow [m³/h (l/s)]	Total sound pressure level (breakout) at 3 m (1 m) distance [dB(A)]
1	135 (37) @ 0 Pa	30 (40)
2	110 (30) @ 84 Pa	30 (39)
3	68 (19) @ 166 Pa	29 (38)
4	95 (26) @ 0 Pa	24 (33)
5	95 (26) @ 50 Pa	22 (32)
6	54 (15) @ 0 Pa	13 (23)

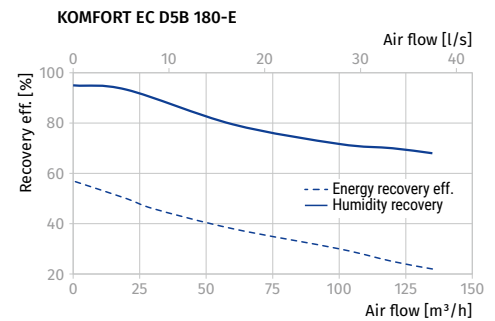
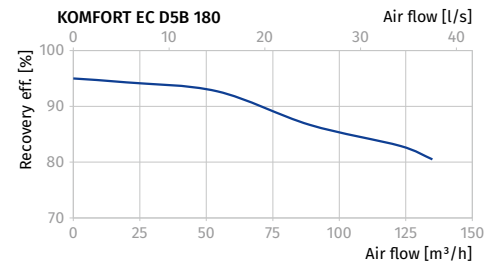
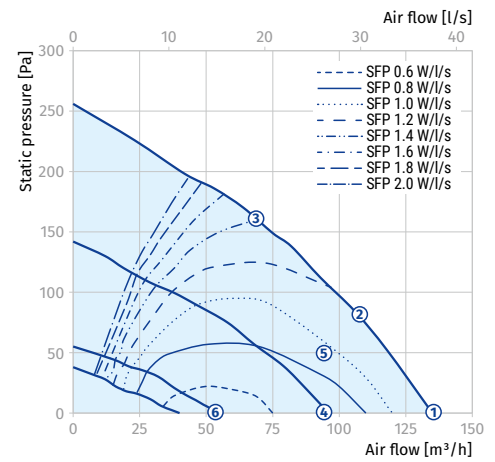











RENEO-FIT D 100

Exhaust terminal configuration	Air flow rate [l/s]	Specific fan power [W/l/s]	Heat exchange efficiency [%]
Kitchen + 1 additional wet room	15	0.6	92
Kitchen + 2 additional wet rooms	21	0.73	88
Kitchen + 3 additional wet rooms	29	0.90	85
Kitchen + 4 additional wet rooms	37	1.20	80

RENEO-FIT D 100-E

Exhaust terminal configuration	Air flow rate [l/s]	Specific fan power [W/l/s]	Heat exchange efficiency [%]
Kitchen + 1 additional wet room	15	0.65	80
Kitchen + 2 additional wet rooms	21	0.75	75
Kitchen + 3 additional wet rooms	29	0.93	71
Kitchen + 4 additional wet rooms	37	1.20	69

Accessories

		Reneo-Fit D 100 S14	Reneo-Fit D 100-E S14
G4 panel filter		FP 176x160x22 G4	FP 176x160x22 G4
F7 panel filter		FP 176x160x22 F7	FP 176x160x22 F7
Control panel		S14	S14
Humidity sensor		FS2	FS2
Humidity sensor		HR-S	HR-S
CO ₂ sensor		CD-2	CD-2
CO ₂ sensor with indication		CD-1	CD-1
Syphon kit (for the units without an enthalpy heat exchanger)		SFK 20x32	SFK 20x32
Air damper		VKA 125	VKA 125
Electric actuator		TF230	TF230