



AXIAL FANS



Sileo Design

OPERATION MANUAL

EN



BLAUBERG
Ventilatoren



WARNING

Follow the user's manual requirements to ensure durable and trouble-free operation of the fan.

Disconnect the fan from power supply prior to any connection, servicing and repair operations.

Only duly qualified electricians with valid electrical permit for electric operations at the units with operating voltage up to 1000 V are allowed for mounting and maintenance after careful study of the present user's manual.

The single-phase power mains must comply with the acting local electrical norms and standards.

The fixed electrical wiring must be equipped with an automatic circuit breaker.

The fan must be connected to power mains through an automatic circuit breaker QF integrated into the fixed wiring system with the gap between the breaker contacts on all poles not less than 3 mm.

Check the fan for any visible damages of the impeller and the casing before starting installation. The casing internals must be free of any foreign objects which can damage the impeller blades.

Due to constant improvements the design of some models may slightly differ from those ones described in this manual.

Follow the user's manual requirements to ensure durable and trouble-free operation of the fan.



WARNING

While mounting the fan avoid the casing compression!

Deformation of the casing may result in the motor jam and excessive noise.

Misuse of the fan and any unauthorised modifications are not allowed. Take steps to prevent ingress of smoke, carbon monoxide and other combustion products into the room through open chimney flues or other fire-protection devices. Sufficient air supply must be provided for proper combustion and exhaust of gases through the chimney of fuel burning equipment to prevent back drafting.

Transported air must not contain any dust or other solid impurities, sticky substances or fibrous materials.



WARNING

Follow the user's manual requirements to ensure durable and trouble-free operation of the fan.

Do not use the fan in a hazardous or explosive environment containing spirits, gasoline, insecticides, etc.

Do not close or block the fan intake or extract vents in order to ensure the efficient stream.

Do not sit on the fan and do not put objects on it.

The timer circuit is live.

Disconnect the fan from power supply prior to any adjustment operations.

The fan delivery set includes a specially designed plastic screwdriver for adjustment of the fan parameters.

Use the plastic screwdriver to change the turn-off delay time.

Follow the user's manual requirements to ensure durable and trouble-free operation of the fan.



WARNING

The product is allowed to be used by children aged from 8 years and above and persons with reduced physical, sensory or mental capabilities or lack of experience and knowledge provided that they have been given supervision or instruction regarding a safe use of the product and understand the risks involved.

Do not allow children play with the product.

Fan cleaning and maintenance must only be performed by children under adult supervision.



Recycle at the end of the service life.

Do not dispose the product with unsorted municipal trash.

Read the user's manual carefully before installation works. Compliance with the manual requirements ensures reliable operation and long service life of the product. Keep the user's manual available as long as you use the product. You may need to re-read the information on the product servicing.

DELIVERY SET

1. Fan – 1 item
2. Screws and dowels – 4 items
3. Plastic screwdriver – (only for the models with a timer) – 1 item
4. User's manual
5. Packing box

BRIEF DESCRIPTION

The products an axial fan for exhaust ventilation of small to medium-sized premises.

The fan is designed for connection to 100 mm air ducts.

This fan model includes a back valve that prevents air back drafting when the fan is off.

Fan options:



S - the fan is turned on and off with a pull cord switch.



T - After turning the switch off, for example, a light switch, the fan keeps operating for a set turn-off delay time, adjustable from 2 to 30 minutes.

T1 - After the fan is turned on with an external switch, for example, a light switch, the fan is activated in a set turn-on delay time period, adjustable from 0 to 2 minutes. After the switch is turned off the fan keeps operating for a set turn-off delay time period, adjustable from 2 to 30 minutes.



H - The fan is turned on as the indoor humidity exceeds set level, adjustable from 60 % up to 90 %.

As the indoor humidity level drops down below the set point, the fan keeps operating for a set turn-off delay time period, adjustable from 2 to 30 minutes. The fan may be manually turned on with a light switch. After the switch is turned off the fan keeps operating for a set turn-off delay time period, adjustable from 2 to 30 minutes.

OPERATION GUIDELINES

The fan is rated for connection to single-phase AC power mains:

220...240 V / 50 Hz or 220...240 V / 60 Hz power supply, depending on the model type. For more detailed information, see the casing sticker.

The fan is rated for operation at the ambient temperature ranging from +1 °C up to +45 °C.

Ingress protection rating against access to hazardous parts and water ingress is IP45.

The fan requires no grounding.

MOUNTING

The fan is designed for wall mounting (Fig. 1) or ceiling mounting (Fig. 2) and connection to a ventilation shaft or a round air duct of a matching diameter.

Attention! In case of vertical mounting the fan must be protected against ingress of rainfalls and condensate inside the fan.

Fan installation with direct air discharge upwards is not allowed, Fig. 3.

The fan mounting sequence is shown in Fig. 5–13.

The fan wiring diagrams are shown in Fig. 14–16.

Warning! Only for T1.

If the turn-on delay timer was activated by the external switch, light switch, motion sensor, but during the timer countdown the triggered action is cancelled, i.e. the external switch is turned OFF, the motion is not detected more, the indoor humidity level drops down below the set point, the fan operates in the previous operation mode.

MAINTENANCE

The fan maintenance periodicity is at least once per 6 months.

Uplift the latches carefully to open the front cover with a flat screwdriver, Fig. 19.

To clean the fan use a soft cloth or a brush wetted in a mild detergent solution, Fig. 20–21.

WARNING! Avoid water dripping on the electric components.

Wipe the fan surfaces dry after cleaning.

TRANSPORTATION AND STORAGE RULES

Transportation with any transportation vehicle in the manufacturer's original package.

Store the delivered product in the manufacturer's original packing box in a dry ventilated premise with the temperature from +5 °C up to + 40 °C and relative humidity below 80 %.

The storage environment must not contain dust, acid or alkali vapours that may cause corrosion of the product parts.

MANUFACTURER'S WARRANTY

We hereby declare that the product complies with the essential protection requirements of Electromagnetic Council Directive 2004/108/EC, 89/336/EEC and Low Voltage Directive 2006/95/EC, 73/23/EEC and CE-marking Directive 93/68/EEC on the approximation of the laws of the Member States relating to electromagnetic compatibility.

This certificate is issued following test carried out on samples of the product referred to above.

The manufacturer sets forth the warranty period of the fan as 60 months following the sale date via retail network subject to the customer's ensuring compliance with the rules of transportation, storage, mounting and operation.

In case of any malfunction of the fan through the manufacturer's fault within the warranty period the customer is entitled to free elimination of the defects by means of warranty repair.

The warranty repair means performing works specific to elimination of faults in the fan operation to ensure its intended use by the user within the warranty period.

The defects are eliminated by means of replacement or repair of the complete fan or a faulty part thereof.

The warranty repair does not include:

- Routine maintenance.
- Fan installation / dismantling.
- Fan setup.
- To benefit from warranty repair the user must provide the fan, the user's manual with stamped sale date and the payment document to confirm the purchase.
- The fan model must comply with the one stated in the user's manual.
- Contact the product seller for warranty service, repair or replacement.

The manufacturer's warranty does not apply to the following cases:

- User's failure to provide the fan in the entire delivery package as stated in the user's manual, including missing component parts previously dismantled by the user.
- Mismatch of the fan model and make with the respective details stated on the fan packing and in the user's manual.
- User's failure to ensure timely technical maintenance of the fan.

- External damage to the casing (excluding external modifications of the fan as required for its installation) and the internal components of the fan.
- Alteration of the fan design or engineering changes of the fan.
- Replacement and use of the assemblies, parts and components not approved by the manufacturer.
- Not intended use of the fan.
- User's violation of the fan control regulations.
- Fan connection to power mains with a voltage other than the one stated in the user's manual or on the sticker on the fan casing.
- Fan breakdown due to voltage surges in the power mains.
- User's discretionary repair of the fan.
- Repair performed by any persons without the manufacturer's authorization.
- Expiry of the warranty period.
- User's violation of the established regulations specific to the fan transportation.
- User's violation of the fan storage regulations.
- Wrongful acts against the fan committed by third persons.
- Fan breakdown due to circumstances of insuperable force (fire, flood, earthquake, war, hostilities of any kind, blockade, etc.).
- Missing seals if provided by the user's manual.
- Failure to submit the user's manual with the sale date stamp.
- Failure to submit the warranty card.
- Failure to submit a payment document certifying the fan purchase.

FOLLOWING THE REGULATIONS STIPULATED HEREIN WILL ENSURE A LONG AND TROUBLE-FREE OPERATION OF THE FAN.

USERS' CLAIMS SHALL BE SUBJECT TO REVIEW ONLY UPON SUBMISSION OF THE FAN, THE PAYMENT DOCUMENT AND THE USER'S MANUAL WITH THE SALES DATE STAMP.

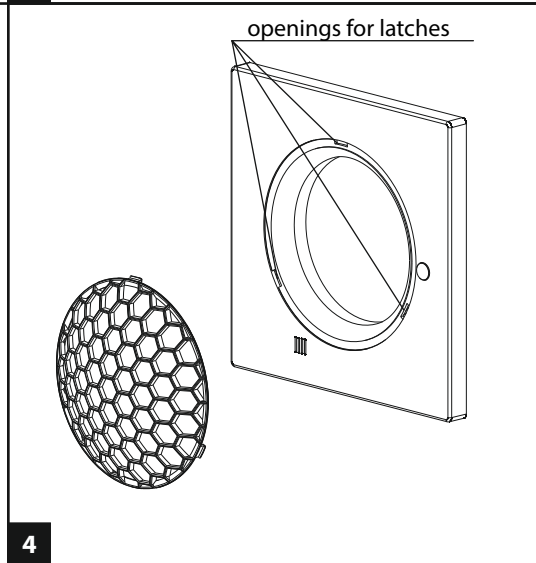
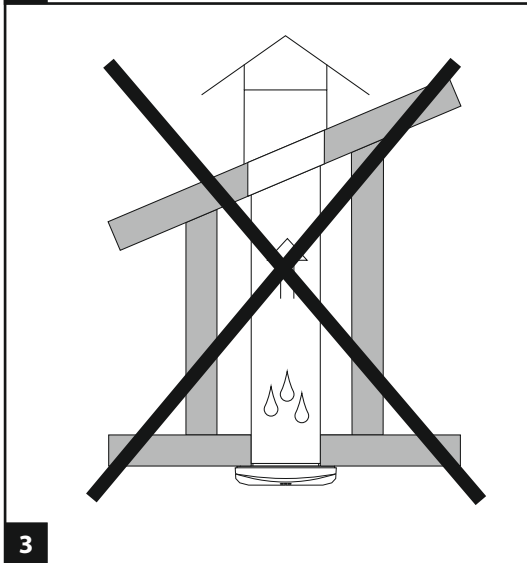
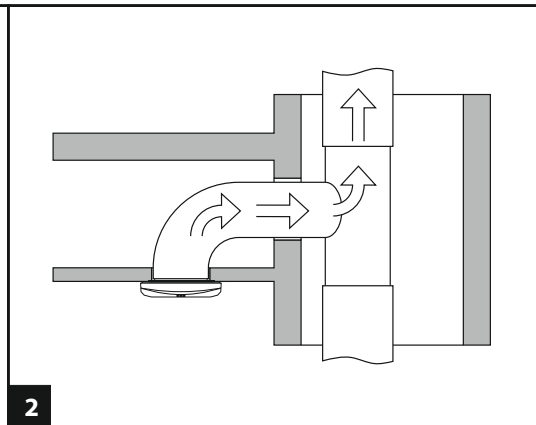
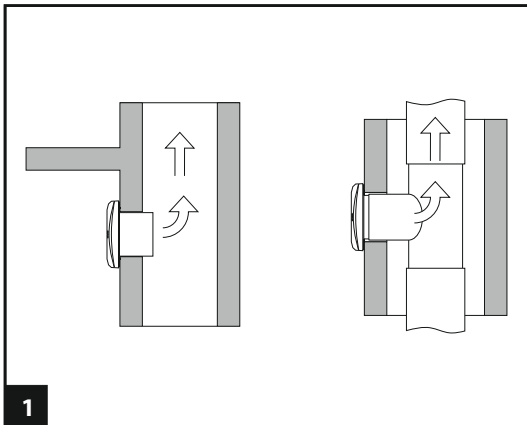

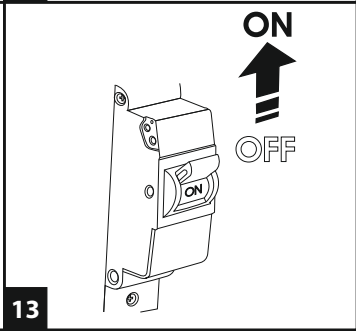
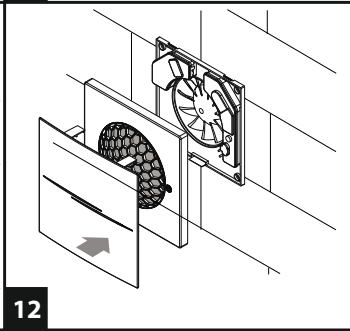
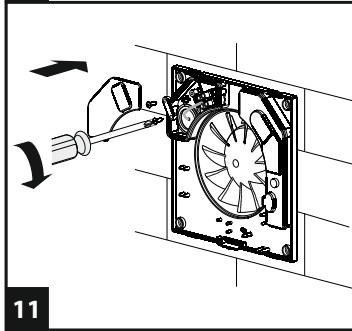
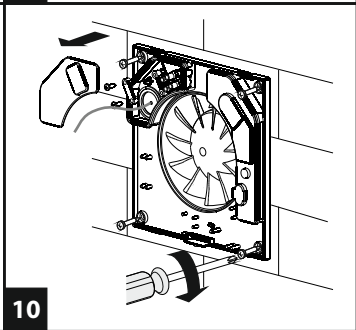
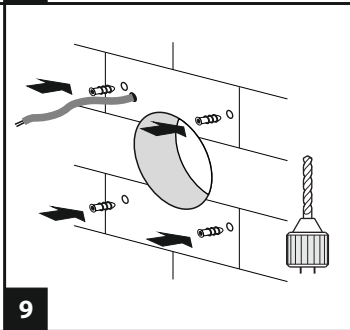
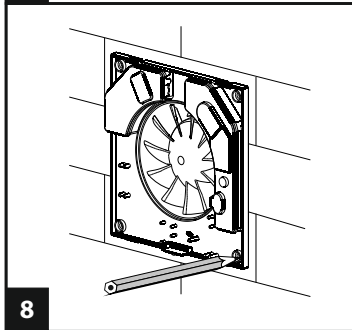
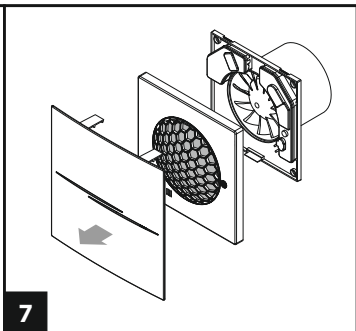
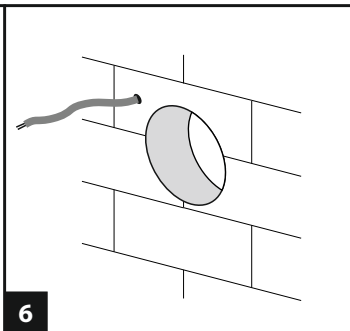
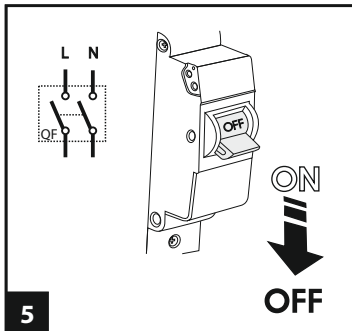

Sileo Design 100

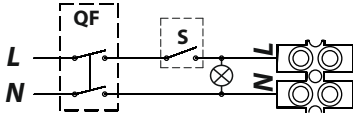
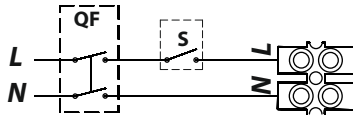

Sileo Design 100 S

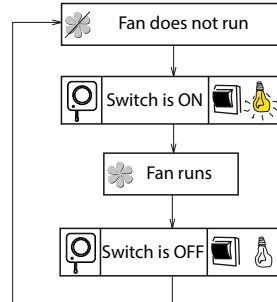
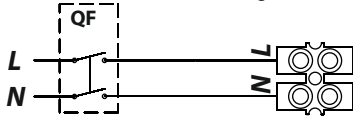

14

T/T1/ST

Sileo Design 100 T/T1

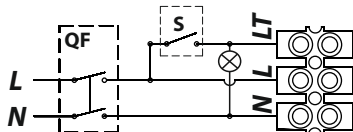
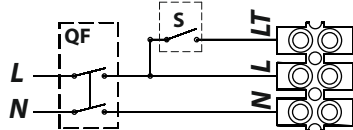

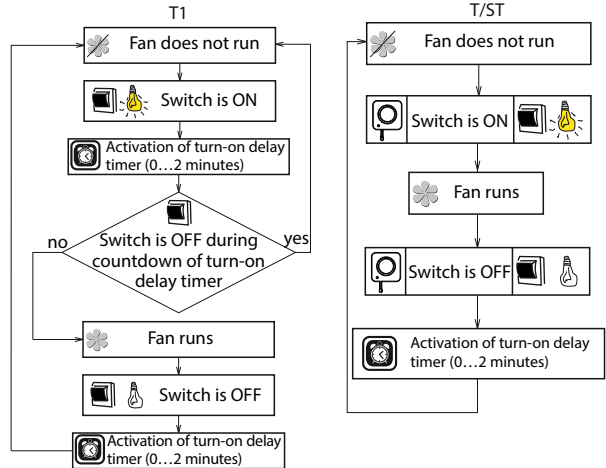
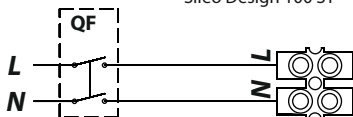

Sileo Design 100 ST



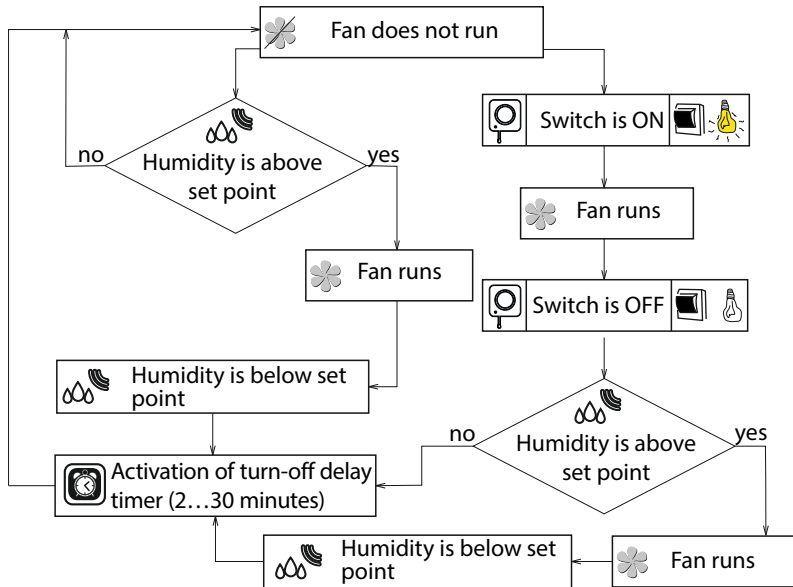
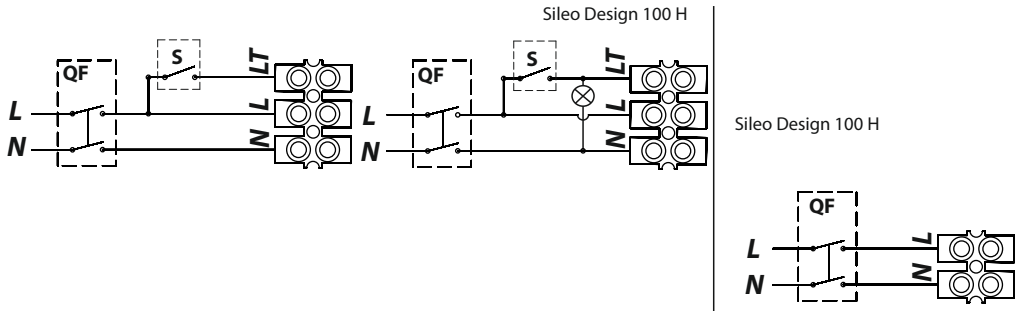

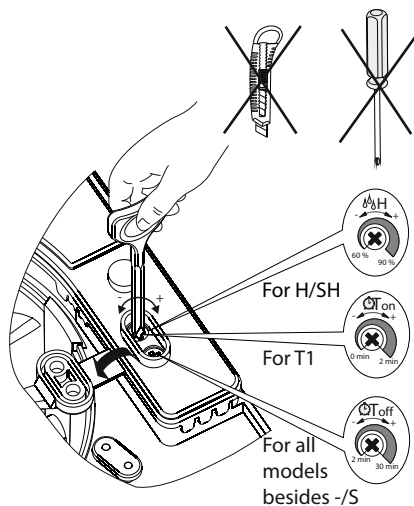
15





 **H** To adjust the humidity set point turn the control knob **H** clockwise to increase and counter-clockwise to decrease the humidity sensor set point, adjustable from 60 % up to 90 %.

 **T_{on}** To adjust the fan turn-on delay time, turn the control knob **T_{on}** clockwise to increase and counter-clockwise to decrease the turn-on delay time respectively, adjustable from 0 up to 2 minutes.

 **T_{off}** To adjust the fan turn-off delay time, turn the control knob **T_{off}** clockwise to increase and counter-clockwise to decrease the turn-off delay time respectively, adjustable from 2 up to 30 minutes.

Warning! The timer circuit is under mains voltage! Disconnect the fan from power supply prior to any adjustment operations.

The fan delivery set includes a specially designed plastic screwdriver for fan settings adjustments. Use it to change the turn-on and turn-off delay time and the humidity set point.

Do not use a metal screwdriver, knife, etc. for adjustment operations not to damage the circuit board.

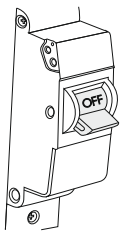

ON
↓
OFF

18

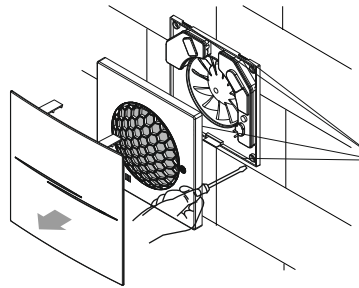

Latches

19

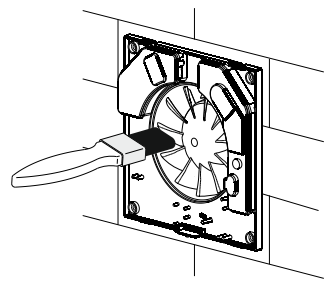

20

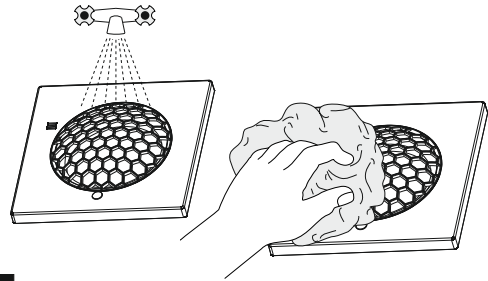

21

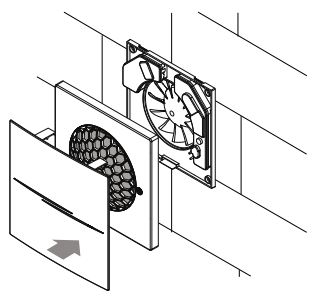

22

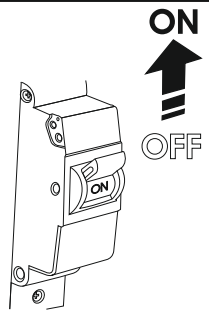

ON
↑
OFF

23

ACCEPTANCE CERTIFICATE

WARRANTY CARD

S

Sileo Design 100 T H

T1 SH

ST

The fan is recognized as serviceable.

Approval mark

Manufacturing date

Sold by
(name of the vendor, stamp of the shop)

Date of sale

