

TOWER-SV-K2

Roof-mounted centrifugal fan for smoke extraction with vertical air discharge

Use

- Smoke extraction fans are used in emergency exhaust ventilation systems for forced extraction of smoke and heated gases and simultaneous transfer of heat away and beyond the limits of the serviced spaces in case of fire.
- Such units are used in production, public, residential, administrative and other spaces.



Air flow:
up to 86 500 m³/h



Transported air temperature:
600 °C/2 hours



Operation

- The fans are capable of handling smoke and air mixtures with temperatures up to +600 °C for 120 minutes.
- The fans can operate in conjunction with a frequency converter (hereinafter referred to as FC) or directly when connected to power supply.
- The aerodynamic characteristics of the fans for mains operation are given below.
- The fan can be used for general exhaust ventilation.
- The fan can be designed for moderate (U), tropical (T) or maritime moderately cold (M) climate conditions.

Design

- The fans are made of heat resistant steel with polymer coating providing weathering resistance.
- Equipped with a protective grille against accidental touches and ingress of foreign objects.
- The impeller with backward curved blades are painted with powder coating.
- Can be additionally equipped with a service switch.

Motor

- The fans are equipped with three-phase electric motors rated for 400 V.
- The motor is located in the compartment offset from the transported air stream.
- Motor ingress protection rating is IP54.

Installation

- The fans can be installed directly on the roof or on the SM-AF mounting curb.
- Make sure that the location provides for sufficient space as required for the fan maintenance.



SM-AF mounting curb
Detailed information on the SM-AF mounting curb is given in the section "Accessories for roof-mounted smoke extraction fans".

Designation key

Model	Impeller size [mm]	Number of motor poles	Motor phase and operation modes	Motor power [kW]	Options	Climatic modification	Fire resistance	Frequency, Hz	Paint colour
Tower-SV-K2: roof-mounted centrifugal smoke extraction fan with vertical air discharge in an octagonal casing	315; 355; 400; 450; 500; 560; 630; 710; 800; 900; 1000; 1120	- 2; 4; 6; 8; 10	E: single-phase across-the-line motor EP: single-phase motor with variable frequency start D: three-phase motor DP: three-phase motor with variable frequency start	0.12; 0.25; 0.37; 0.55; 0.75; 1.1; 1.5; 2.2; 3; 4; 5.5; 7.5; 11; 15; 18.5; 22; 30; 37; 45	- K: with a terminal box S1: built-in external switch	- U1: temperate climate HL1: cold climate T1: tropical climate M1: maritime moderately cold climate	- 200/2: 200°C/2 hours; 300/2: 300°C/2 hours; 400/2: 400°C/2 hours; 600/2: 600°C/2 hours	- 50 Hz 60Hz: 60 Hz	- RAL7040 gray by default RALxxxx: paint colour according to RALxxxx Zn: galvanized steel

ROOF-MOUNTED SMOKE EXTRACTION FANS

Overall dimensions [mm]

Model	H	A	B	C	Ø d
Tower-SV-K2 315-2D/1.1-K	779	680	480	820	16
Tower-SV-K2 355-4D/0.25-K	744	680	480	820	16
Tower-SV-K2 355-2D/2.2-K	801	680	480	820	16
Tower-SV-K2 400-6D/0.25-K	772	760	580	866	16
Tower-SV-K2 400-4D/0.55-K	897	760	580	880	16
Tower-SV-K2 450-6D/0.25-K	794	760	580	864	16
Tower-SV-K2 450-4D/1.1-K	929	810	640	933	16
Tower-SV-K2 500-8D/0.25-K	888	830	640	950	16
Tower-SV-K2 500-6D/0.55-K	991	830	640	1094	16
Tower-SV-K2 500-4D/1.5-K	921	1000	750	1082	16
Tower-SV-K2 560-8D/0.37-K	991	1000	750	1094	16
Tower-SV-K2 560-6D/0.75-K	991	1000	750	1094	16
Tower-SV-K2 560-4D/3-K	991	1000	750	1094	16
Tower-SV-K2 630-8D/0.75-K	1060	1010	750	1121	16
Tower-SV-K2 630-6D/1.5-K	1105	1180	980	1257	16
Tower-SV-K2 630-4D/5.5-K	1264	1180	980	1267	16
Tower-SV-K2 710-8D/1.1-K	1237	1180	980	1311	16
Tower-SV-K2 710-6D/2.2-K	1387	1180	980	1311	16
Tower-SV-K2 710-4D/11-K	1297	1180	980	1311	16
Tower-SV-K2 800-8D/2.2-K	1297	1340	1050	1494	16
Tower-SV-K2 800-6D/4-K	1448	1340	1050	1494	16
Tower-SV-K2 800-4D/15-K	1600	1340	1050	1524	16
Tower-SV-K2 900-10D/2.2-K	1595	1550	1340	1686	16
Tower-SV-K2 900-8D/7.5-K	1680	1550	1340	1686	16
Tower-SV-K2 900-6D/15-K	1829	1550	1340	1686	16
Tower-SV-K2 1120-10D/7.5-K	1753	1640	1340	1876	16
Tower-SV-K2 1120-8D/11-K	1866	1640	1340	1876	16
Tower-SV-K2 1120-6D/22-K	1789	1640	1340	1876	16
Tower-SV-K2 1120-4D/30-K	1956	1640	1340	1876	16

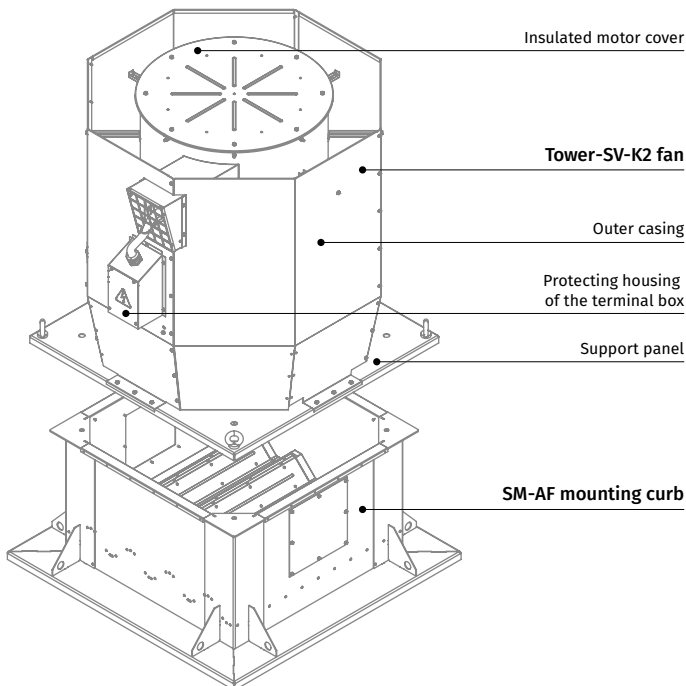
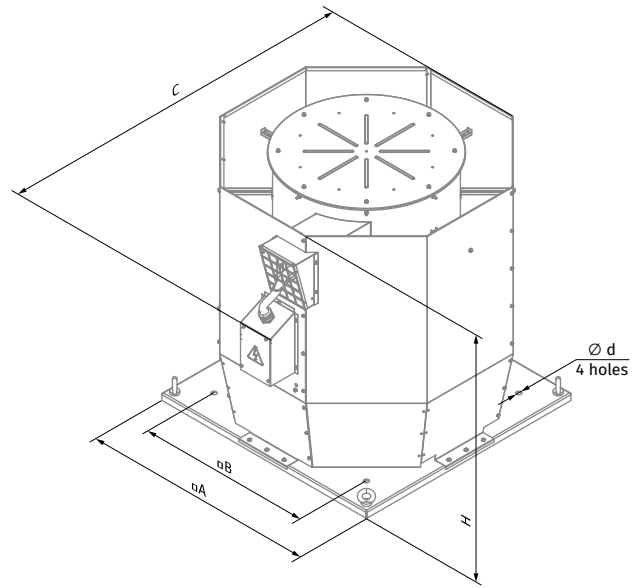

Technical data

Standard size	Number of poles	Voltage [V/50 Hz]	Fan model	Rated power Ny [kW]	RPM [min ⁻¹]	Curve number
315	2	3~400	Tower-SV-K2 315-2D/1.1-K	1.1	2880	①
355	4	3~400	Tower-SV-K2 355-4D/0.25-K	0.25	1335	②
	2	3~400	Tower-SV-K2 355-2D/2.2-K	2.2	2900	③
400	6	3~400	Tower-SV-K2 400-6D/0.25-K	0.25	860	④
	4	3~400	Tower-SV-K2 400-4D/0.55-K	0.55	1345	⑤
	2	3~400	Tower-SV-K2 400-2D/4-K	4	2840	⑥
450	6	3~400	Tower-SV-K2 450-6D/0.25-K	0.25	860	⑦
	4	3~400	Tower-SV-K2 450-4D/1.1-K	1.1	1400	⑧
	2	3~400	Tower-SV-K2 450-2D/7.5-K	7.5	2948	⑨

Standard size: 315

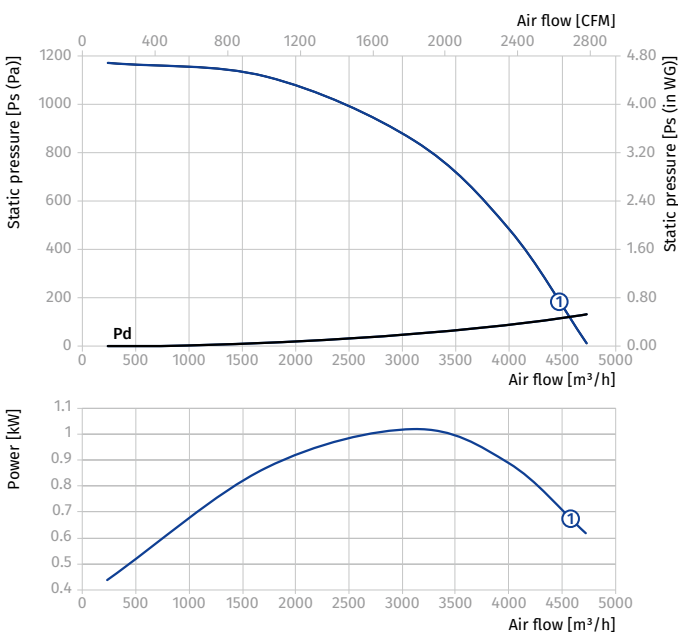

Standard size: 355

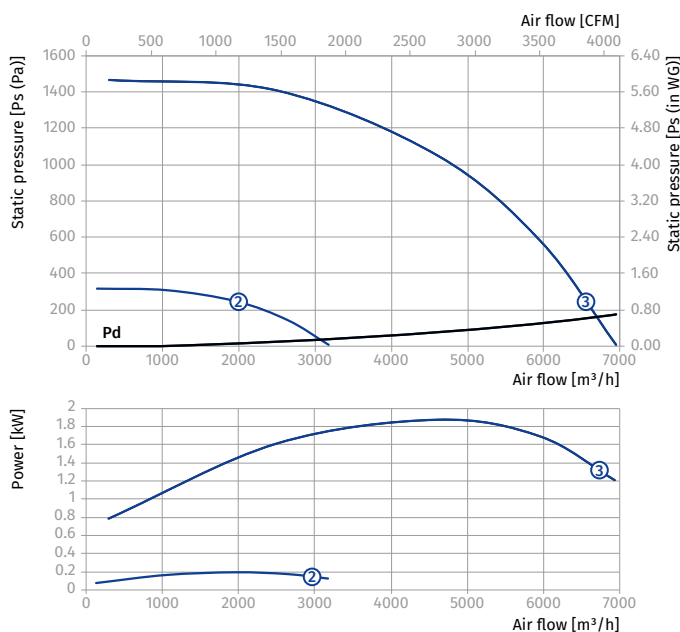

Standard size: 400

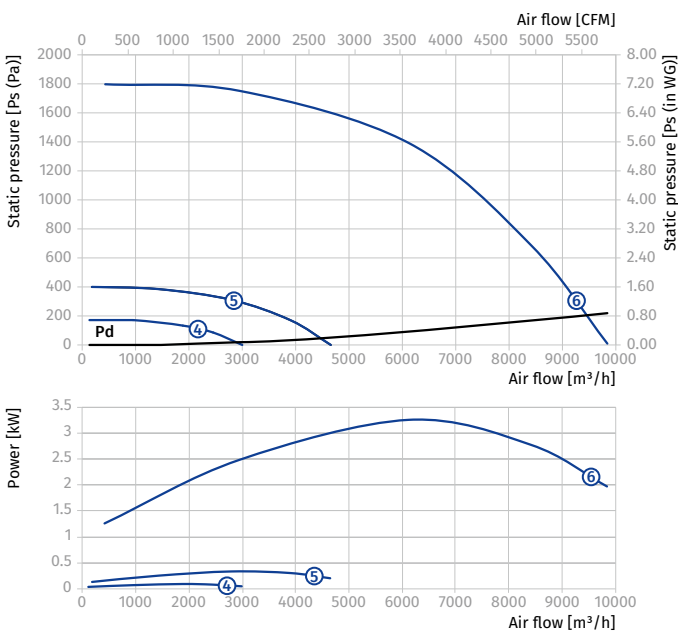

Standard size: 450

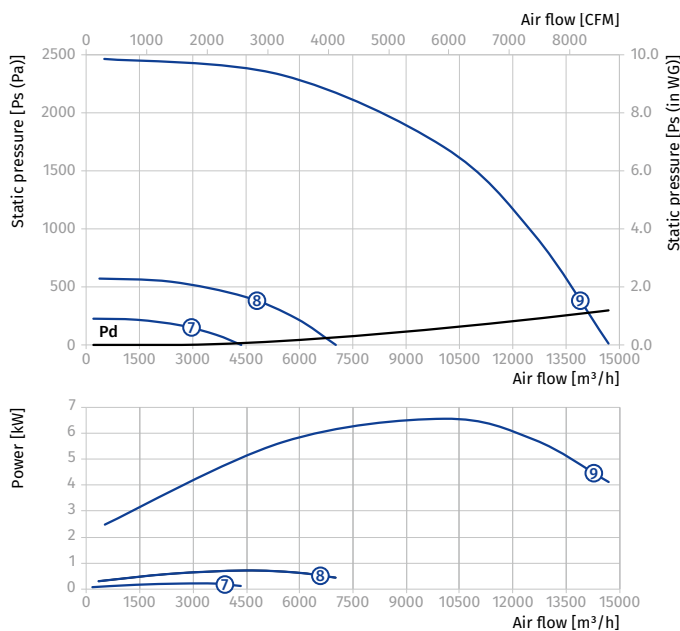

ROOF-MOUNTED SMOKE EXTRACTION FANS

Standard size	Number of poles	Voltage [V/50 Hz]	Fan model	Rated power Ny [kW]	RPM [min ⁻¹]	Curve number
500	8	3~400	Tower-SV-K2 500-8D/0.25-K	0.25	670	①
	6	3~400	Tower-SV-K2 500-6D/0.55-K	0.55	900	②
	4	3~400	Tower-SV-K2 500-4D/1.5-K	1.5	1430	③
560	8	3~400	Tower-SV-K2 560-8D/0.37-K	0.37	665	④
	6	3~400	Tower-SV-K2 560-6D/0.75-K	0.75	940	⑤
	4	3~400	Tower-SV-K2 560-4D/3-K	3	1435	⑥
630	8	3~400	Tower-SV-K2 630-8D/0.75-K	0.75	670	⑦
	6	3~400	Tower-SV-K2 630-6D/1.5-K	1.5	940	⑧
	4	3~400	Tower-SV-K2 630-4D/5.5-K	5.5	1400	⑨
710	8	3~400	Tower-SV-K2 710-8D/1.1-K	1.1	660	⑩
	6	3~400	Tower-SV-K2 710-6D/2.2-K	2.2	945	⑪
	4	3~400	Tower-SV-K2 710-4D/11-K	11	1460	⑫

Standard size: 500

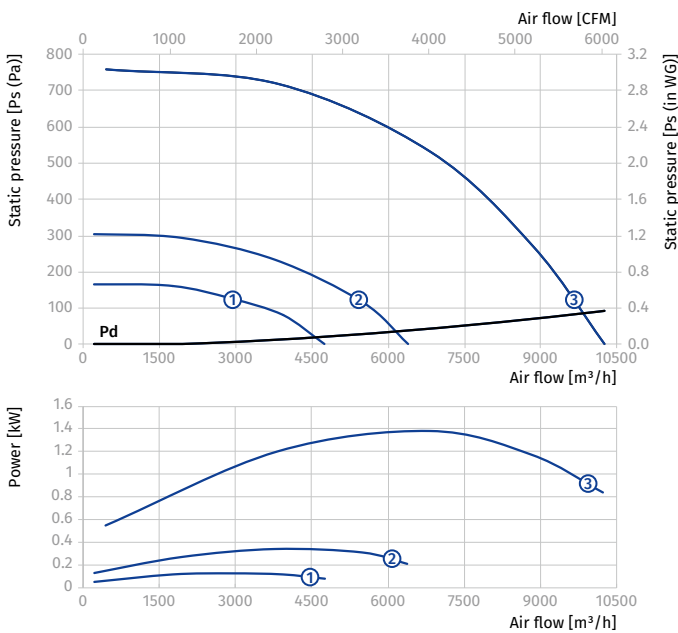

Standard size: 560

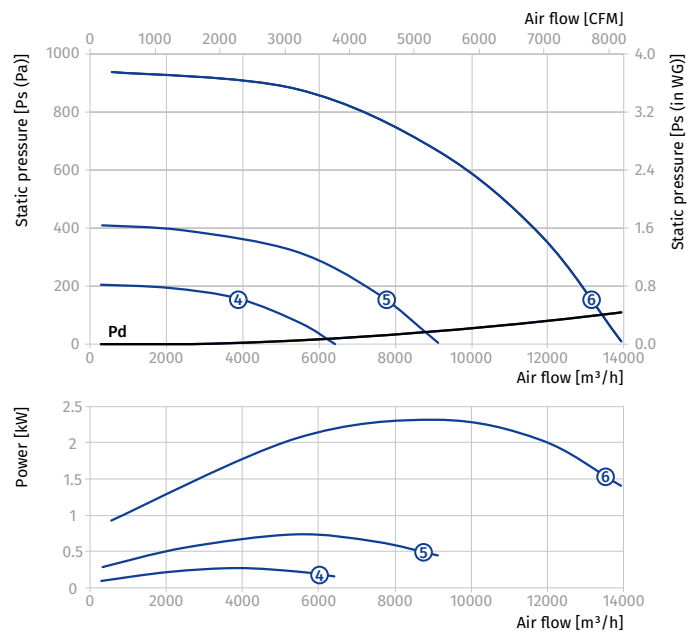

Standard size: 630

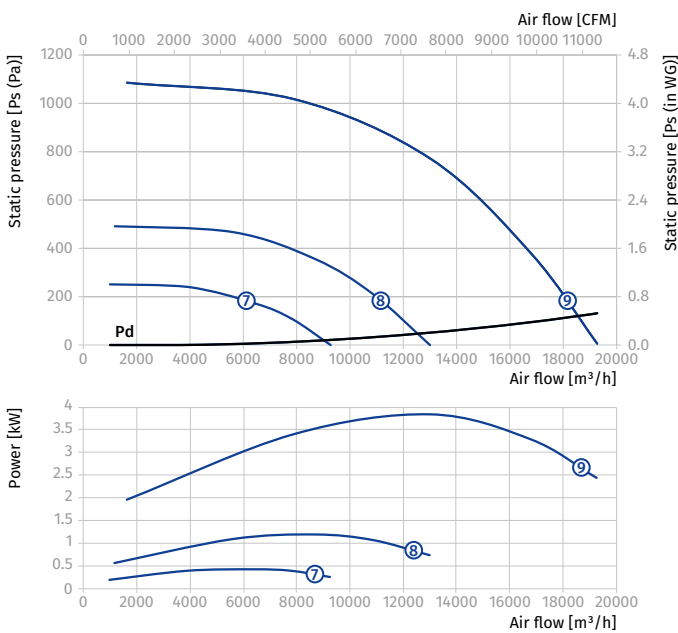

Standard size: 710

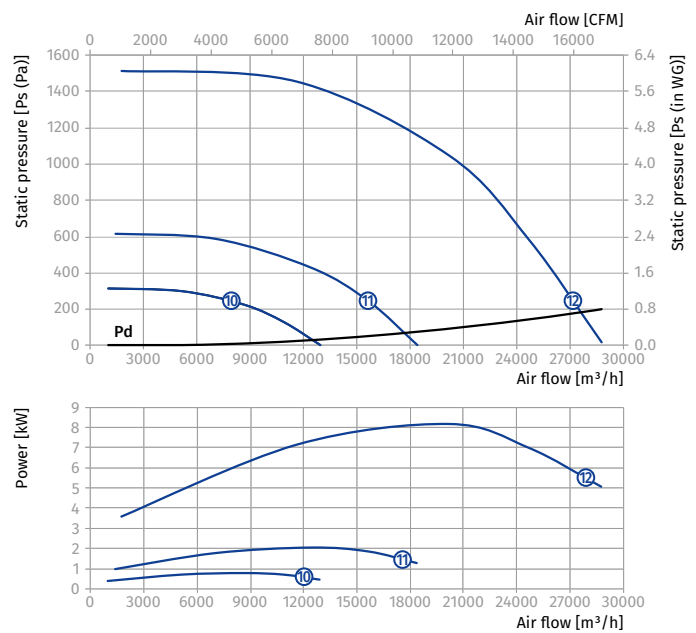

Standard size	Number of poles	Voltage [V/50 Hz]	Fan model	Rated power Ny [kW]	RPM [min ⁻¹]	Curve number
800	8	3~400	Tower-SV-K2 800-8D/2.2-K	2.2	700	①
	6	3~400	Tower-SV-K2 800-6D/4-K	4	965	②
	4	3~400	Tower-SV-K2 800-4D/15-K	15	1460	③
900	10	3~400	Tower-SV-K2 900-10D/2.2-K	2.2	590	④
	8	3~400	Tower-SV-K2 900-8D/4-K	4	700	⑤
	6	3~400	Tower-SV-K2 900-6D/7.5-K	7.5	970	⑥
	4	3~400	Tower-SV-K2 900-4D/30-K	30	1470	⑦
1000	10	3~400	Tower-SV-K2 1000-10D/3-K	3	590	⑧
	8	3~400	Tower-SV-K2 1000-8D/7.5-K	7.5	705	⑨
	6	3~400	Tower-SV-K2 1000-6D/15-K	15	975	⑩
1120	10	3~400	Tower-SV-K2 1120-10D/7.5-K	7.5	590	⑪
	8	3~400	Tower-SV-K2 1120-8D/11-K	11	720	⑫
	8	3~400	Tower-SV-K2 1120-8D/15-K	15	730	⑬
	6	3~400	Tower-SV-K2 1120-6D/22-K	22	975	⑭
	6	3~400	Tower-SV-K2 1120-6D/30-K	30	980	⑮

Standard size: 800

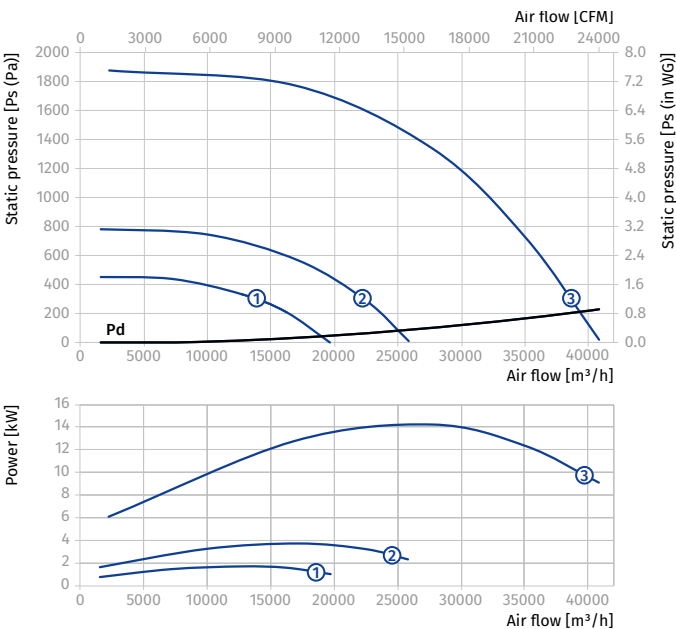

Standard size: 900

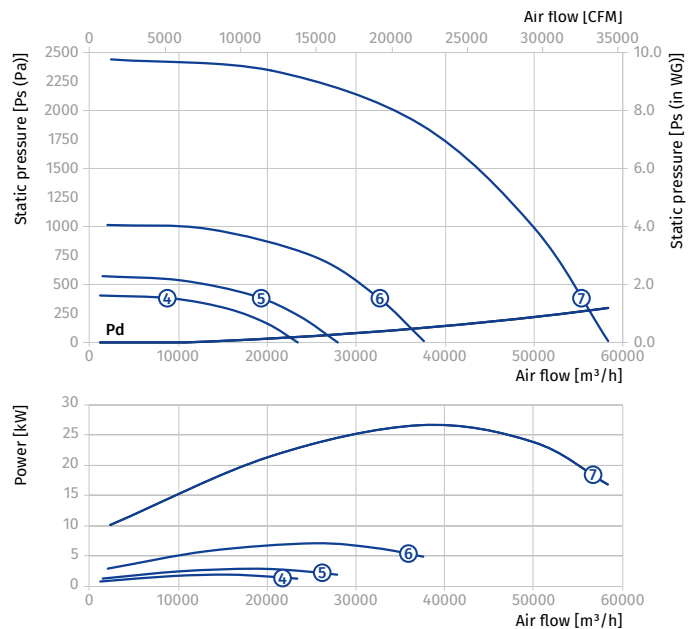

Standard size: 1000

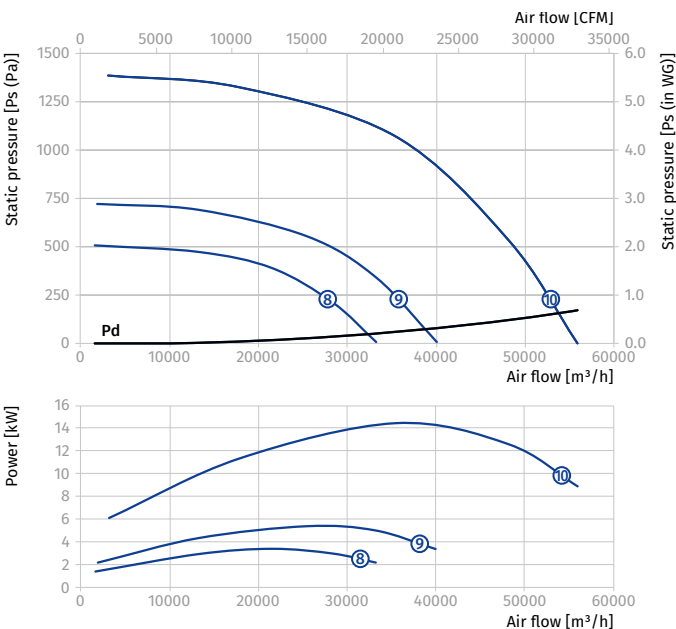

Standard size: 1120

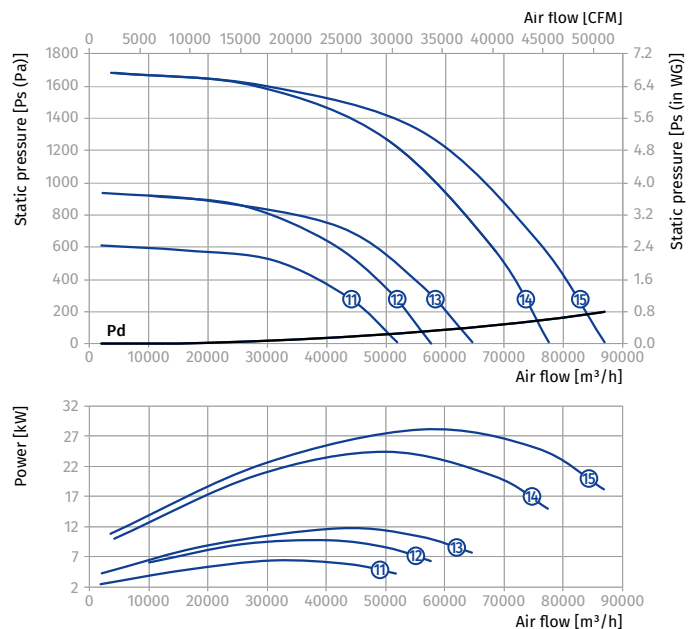

ROOF-MOUNTED SMOKE EXTRACTION FANS