

VALEO

CENTRIFUGAL FANS

Use

- Exhaust ventilation systems installed in high-rise buildings and premises.
- For buildings with a mono-pipe ventilation system.
- For mounting in kitchens and bathrooms.
- Installation in a casing for flush or surface mounting.



Air flow:
up to 100 m³/h
28 l/s



Power:
from 15 W
SFP:
from 1.04 W/l/s



Noise level:
from 27 dBA



Design

- The Valeo ventilation unit is designed for installation in a plastic or fire-proof casing.
- The front panel is made of snow-white UV-resistant plastic.
- Filter with filter class G4 for motor, impeller and ductwork system protection against soiling.
- The filter is easily accessible for service operations.
- The ventilation unit with the motor is fixed inside the casing with special latches.
- Due to modern design and various colour modifications the front panel matches well with any interior.

Motor

- Two-speed motor with a centrifugal impeller. Minimum energy demand.
- The impeller has forward curved blades.
- Automatic maintaining of constant air flow depending on variable air resistance of the duct.
- Balanced impeller ensures low noise operation.
- Best aerodynamic characteristics due to a special scroll casing design.
- Ball bearings provide long service life.

Speed control

- Step speed control with an external speed controller, e.g. a CDP-3/5 model which is available upon order.
- Wide range of system controls with programmable parameters (timer, adjustable timer, internal switch, humidity sensor).

Options

- Timer (Valeo...T)**
Depending on wiring connection the fan is off or runs permanently at low speed. The fan is turned to higher speed with an external switch 50 s after activation. After turning the switch off the fan continues operating within 6 min at higher speed and then reverts to the default operation mode.
- Adjustable timer (Valeo...TR)**
Depending on wiring connection the fan is off or runs permanently at low speed. If the fan is turned on with an external switch, it switches to higher speed 0 to 150 s after switch activation. After turning the fan off it continues running at higher speed within 2 to 30 minutes and then reverts to the previous mode. The fan run-out time and delay time for higher speed are regulated with the internal regulator.
- Interval switch (Valeo...I)**
Depending on wiring connection the fan is off or runs permanently at low speed. In interval mode regulated from 0.5 to 15 hours the fan switches periodically to higher speed for 10 minutes. The switch interval is adjusted with the internal regulator. If the light in the room is turned on, the fan switches to higher speed in 50 s. After light is off the fan reverts to the interval mode operation.
- Humidity sensor (Valeo...H)**
Depending on wiring connection the fan is off or runs permanently at low speed. The fan switches to higher speed as relative humidity in the room increases from 60 % up to 90 % and switches off as humidity drops by 10 % below the set level. If the light in the room is turned on, the fan switches to higher speed in 50 s. The run-out time is set by the internal regulator from 2 to 30 minutes.

Designation key

| | | |
|-------|-----------------------------|--------|
| Valeo | 35/60 | TR |
| Model | Air flow according to speed | Option |

Accessories

| Filter | Flexible air duct | Speed controller | Clamp |
|---|---|---|---|
|  |  |  |  |
| FP-Valeo | BlauFlex AN | CDP-2/5 | K |

VALEO

CENTRIFUGAL FANS

Plastic mounting casing

- o BP 80: plastic casing for flush mounting.
- o Made of quality ABS plastic and equipped with a gravity backdraft damper.
- o Installed in a wall or ceiling during general construction works by mounting brackets supplied as a standard.
- o The casing is equipped with oblong slotted joints to facilitate mounting.
- o Connection to the main ventilation shaft with flexible air ducts.
- o Exhaust spigot diameter 80 mm.
- o After installation works cover the unit with a protecting cover to prevent dirt ingress.
- o After finishing works install the Valeo unit inside the casing.
- o For exhaust ventilation of neighbour rooms additional spigots may be connected to the casing.



Gravity backdraft damper

Mounting example

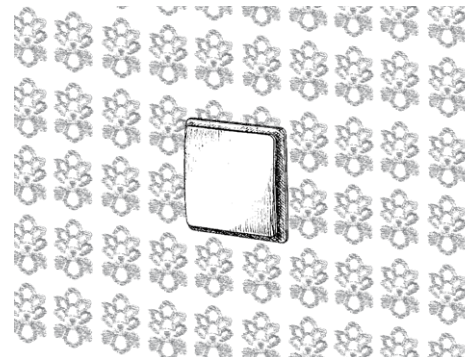
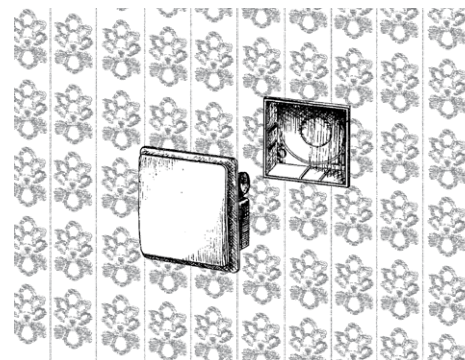
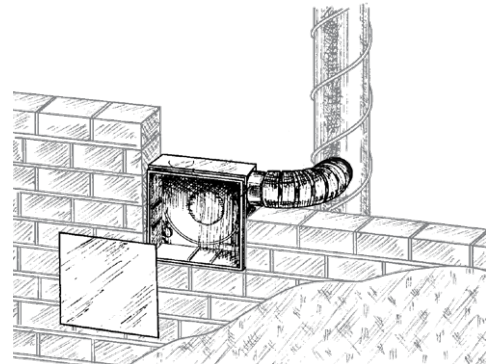

VALEO

CENTRIFUGAL FANS

Mounting fireproof casing

- **BF 80**: fireproof casing for flush mounting.
- Made of silicate plates based on calcium silicate and has high thermal insulating properties.
- Equipped with a fire-retarding damper to prevent fire and smoke expanding along air ducts. If temperature in the duct reaches 90°C the thermal fuse closes the damper.
- When the fan is off, the fire-retarding damper serves as a backdraft damper.
- The fan casing is installed in a wall or ceiling during general construction works by mounting brackets supplied as a standard.
- Connection to the main ventilation shaft with flexible air ducts. Exhaust spigot diameter 80 mm.
- Power is supplied to the fan through a sealed electric lead-in on the casing.
- After installation works cover the unit with a protecting cover to prevent dirt ingress.
- After finishing works install the ventilation unit inside the casing and connect it to the wiring system.
- For exhaust ventilation of neighbour rooms extra spigots may be connected to the casing on the left (**BFL** modification), on the right (**BFR** modification), on the bottom (**BFD** modification).



Mounting example

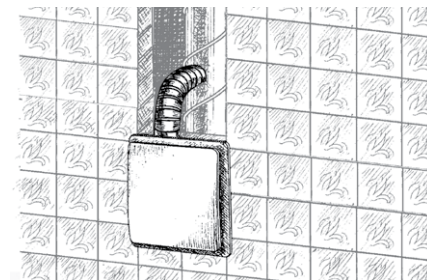
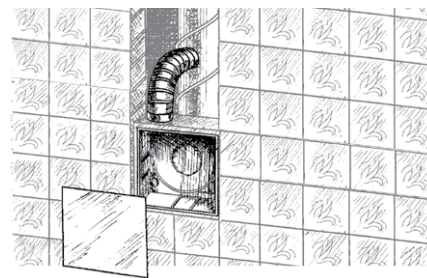
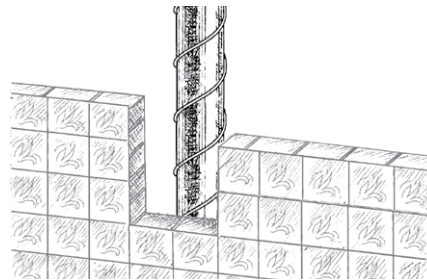

BFL 80



BFR 80



Fire-retarding damper



BFD 80

Overall dimensions [mm]

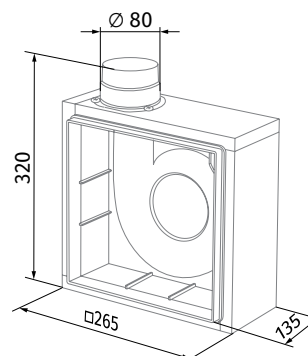
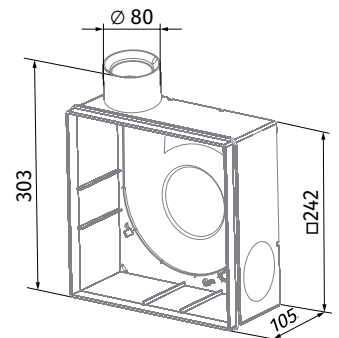
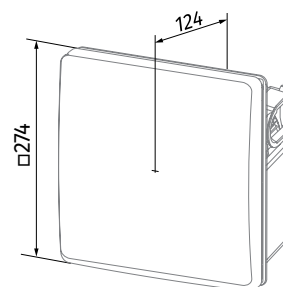

VALEO

CENTRIFUGAL FANS

Technical data

| Model | Valeo 35/60 | Valeo 75/100 |
|--|-------------------|--------------------|
| Speed | I / II | I / II |
| Voltage [V/Hz] | 220-240/50 | 220-240/50 |
| Power [W] | 15 / 25 | 24 / 29 |
| Current [A] | 0.12 / 0.14 | 0.11 / 0.13 |
| Cable cross section [mm ²] | 3x1.5 | 3x1.5 |
| Maximum air flow [m ³ /h (l/s)] | 35 (10) / 63 (18) | 75 (21) / 100 (28) |
| Sound pressure level [dBA]* | 27 / 36 | 29 / 38 |
| Max. transported air temperature [°C] | +50 | +50 |
| IP rating | IP55 | IP55 |

* Sound pressure level measured in free space at a distance of 3 meters from the fan.

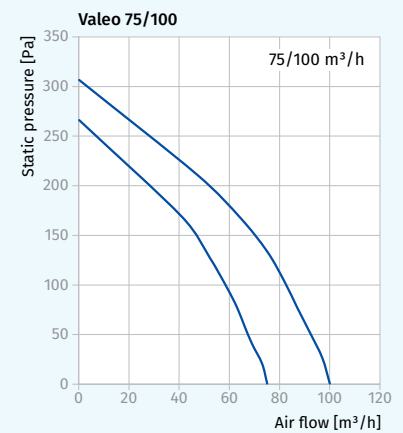
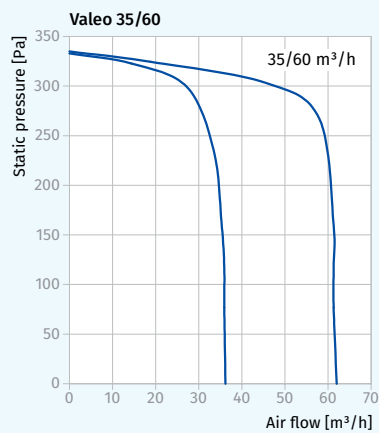

- The abrupt curves show high pressure performance and constant air flow of several **Valeo** fans integrated into a single ventilation shaft.

VALEO

CENTRIFUGAL FANS

Calculation of basic ventilation shaft diameter for mono-pipe ventilation systems

- The charts below display dependence of ventilation shaft dimensions as a function of number of storeys in high-rise buildings with a mono-pipe ventilation system.

VENTILATION OF BATHROOMS OR TOILETS AT THE CALCULATED AIR FLOW RATE OF 60 M³/H

- One fan per each floor, rated air flow 60 m³/h for full operation mode of all fans.

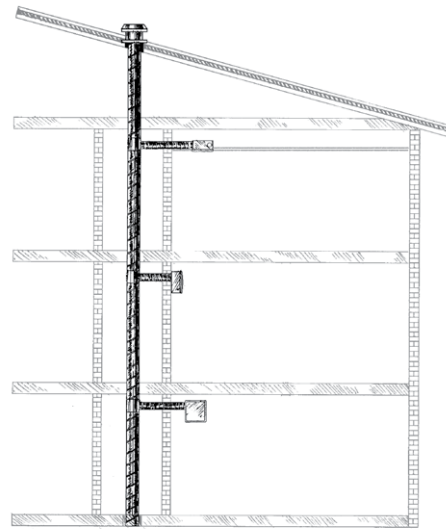
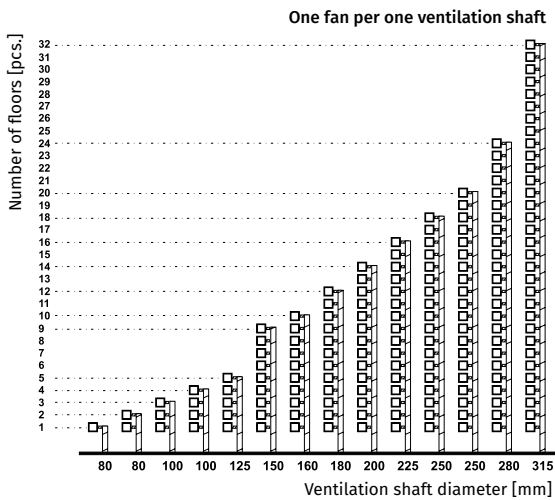

- Two fans per each floor, rated air flow 60 m³/h for full operation mode of all the fans.

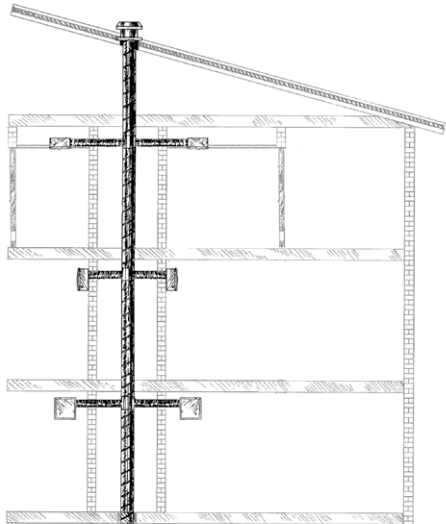
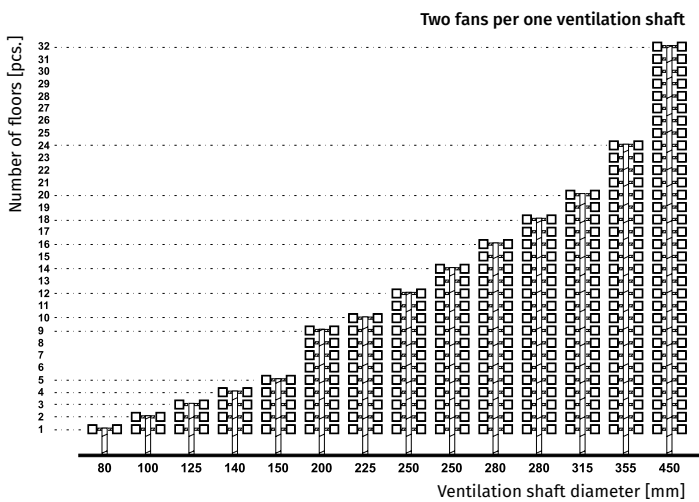

VALEO

CENTRIFUGAL FANS

Calculation of basic ventilation shaft diameter for mono-pipe ventilation systems

- The charts below display dependence of ventilation shaft dimensions as a function of number of storeys in high-rise buildings with a mono-pipe ventilation system.

VENTILATION OF KITCHENS OR SIMULTANEOUS VENTILATION OF TWO SPACES AT THE CALCULATED AIR FLOW RATE OF 100 M³/H

- One fan per each floor, rated air flow for kitchen 100 m³/h for full operation mode of all fans.
- For synchronous room-to-room ventilation: 60 m³/h for bathroom and 40 m³/h for WC.

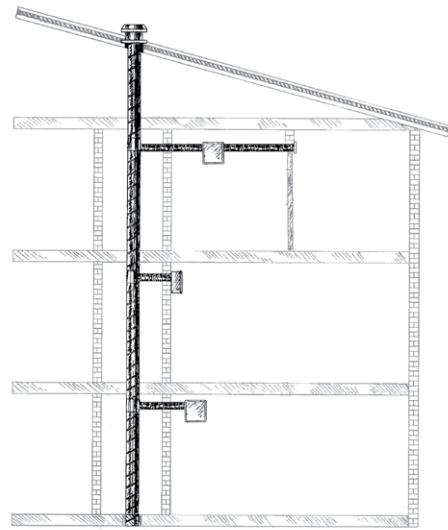
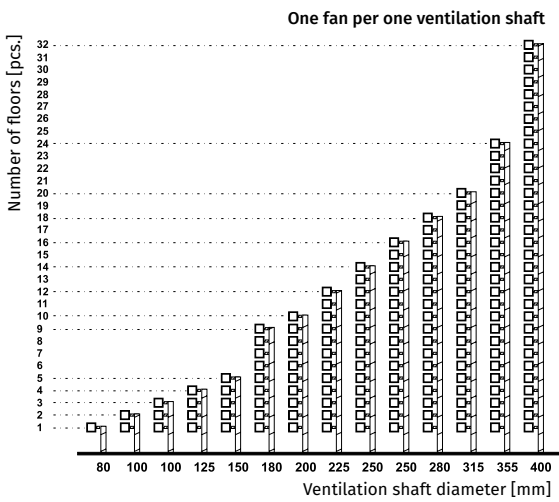

- Two fans per each floor, rated air flow for kitchen 100 m³/h for full operation mode of all the fans.
- For synchronous room-to-room ventilation: 60 m³/h for bathroom and 40 m³/h for WC.

