

HEAT RECOVERY SINGLE-ROOM UNITS

NEW

VENTO A50 VENTO A50-1

Air capacity – up to 53 m³/h
Heat recovery – up to 90 %



Use

- Arrangement of efficient energy-saving supply and exhaust single-room ventilation in flats, houses, cottages, social and commercial premises.
- Heat recovery minimises ventilation heat losses.
- Humidity balance and controllable air exchange create individually set microclimate.
- Coordinated network based on several integrated single-room ventilation units with central control.

Design

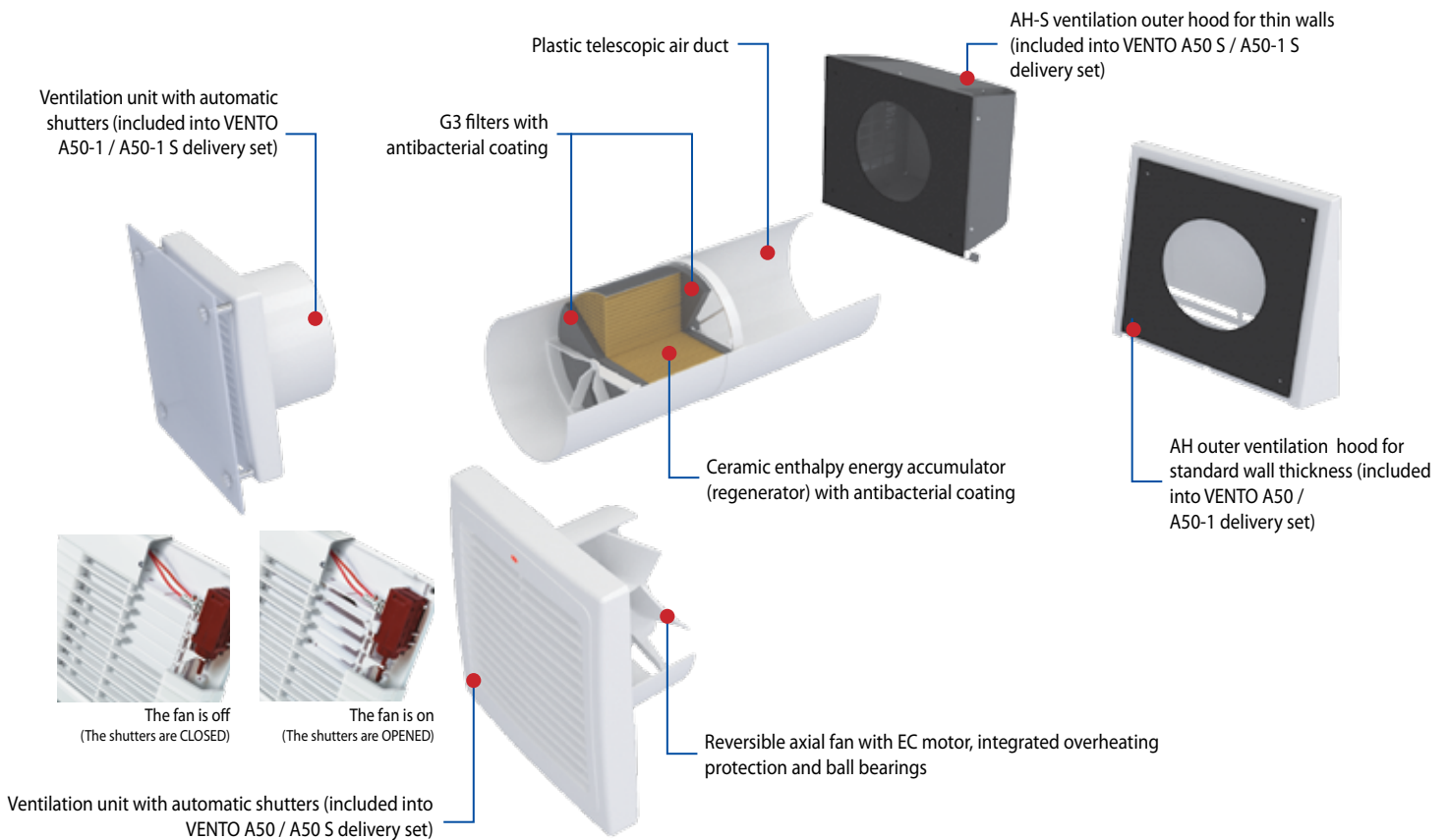

Heat and moisture regeneration

- High-tech ceramic energy accumulator with heat recovery up to 90 % efficiency. The energy accumulator is featured with excellent heat-conducting properties and thermal energy storage capacity.
- Due to its cellular structure it has a larger contact area surface and high

Unit operating logic in winter period

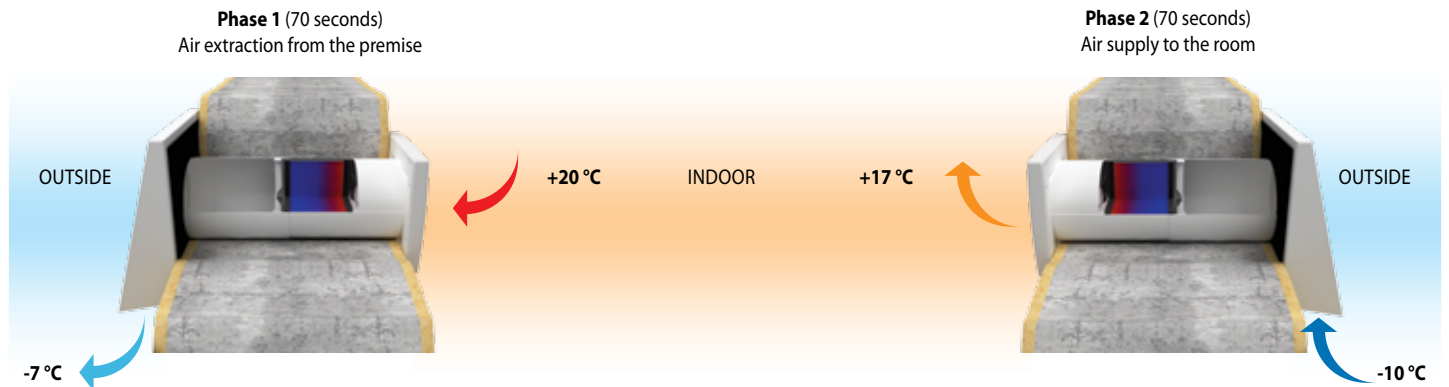

- Warm stale air is extracted from the premise, flows through the ceramic regenerator and transfers a part of the accumulated heat and moisture to it.
- As the ceramic regenerator gets warmed up, the unit switches to the supply mode.
- Clean cold intake air flows through the regenerator and absorbs accumulated heat and humidity.
- When the ceramic regenerator is cooled down, the unit is switched to the extract air mode.

Control

The integrated automation system enables operation of the unit at the first low speed or the second high speed:

- ventilation mode (air supply or air extract);
- reversible heat regeneration mode.

The unit operation mode control is performed by means of an external control block with a power transformer:

- in **VENTO A50 Pro / A50-1 Pro / A50 S Pro / A50-1 S Pro** delivery set included (model SEA-T12);
- available upon separate order for **VENTO A50 / A50-1 / A50 S / A50-1 S** (model SEA-T12 or SEA).

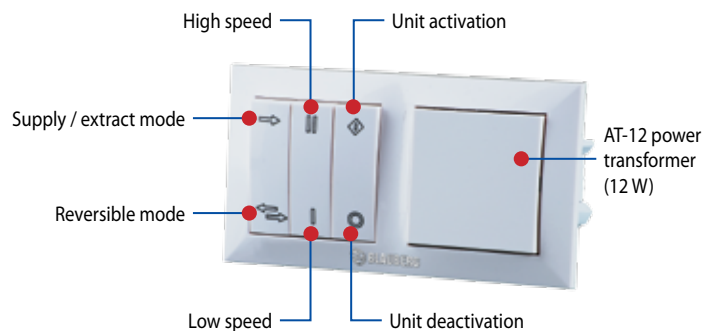

To arrange a central controlled ventilation system based on 4 units connect three VENTO A50 / A50-1 / A50 S / A50-1 S units to one VENTO A50 Pro / A50-1 Pro / A50 S Pro / A50-1 S Pro unit with SEA-T12 control and power unit. No extra accessories are required.



To arrange a central controlled ventilation system based on more than 4 units connect a required number of the units, one SEA three-position switch and several 12 W AT-12 transformers or 40 W AT-40 transformers, depending on the total unit power consumption to one VENTO A50 / A50-1 / A50 S / A50-1 S unit.

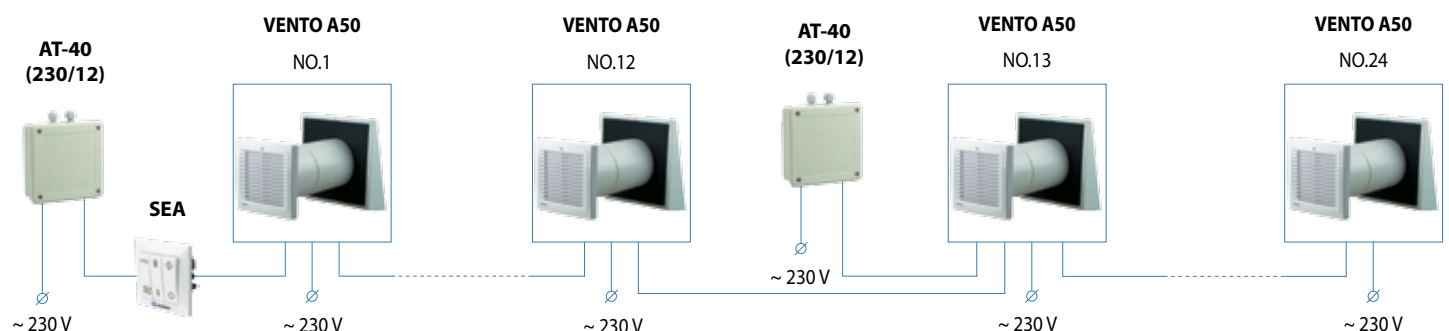

HEAT RECOVERY SINGLE-ROOM UNITS

■ Mounting

- The unit is designed for external through-the-wall installation inside a prepared round hole in the outer wall of the building.
- The best ventilation solution is pairwise installation of reverse phase connected units. Some units supply fresh air to the room and the other units extract stale air from the room. This allows to arrange the most efficient balanced ventilation.
- In case of brand new construction the units are mounted in two stages:

• **pre-installation** at the stage of the indoor finishing and outer decorative wall

finishing. It includes installation of the telescopic air ducts, outer ventilation hood and laying out of electric cables.

• **final mounting** before commissioning of a house. It includes installation of the regenerator, the filter, connection of the ventilation unit and automation.

- If mounting of the ventilation hood on the outer wall is undesirable it may be flush mounted and the external grille may be inserted into the outer window jamb using the **KIT BlauPlast 204x60-1** pre-installation kit. Available upon separate order.

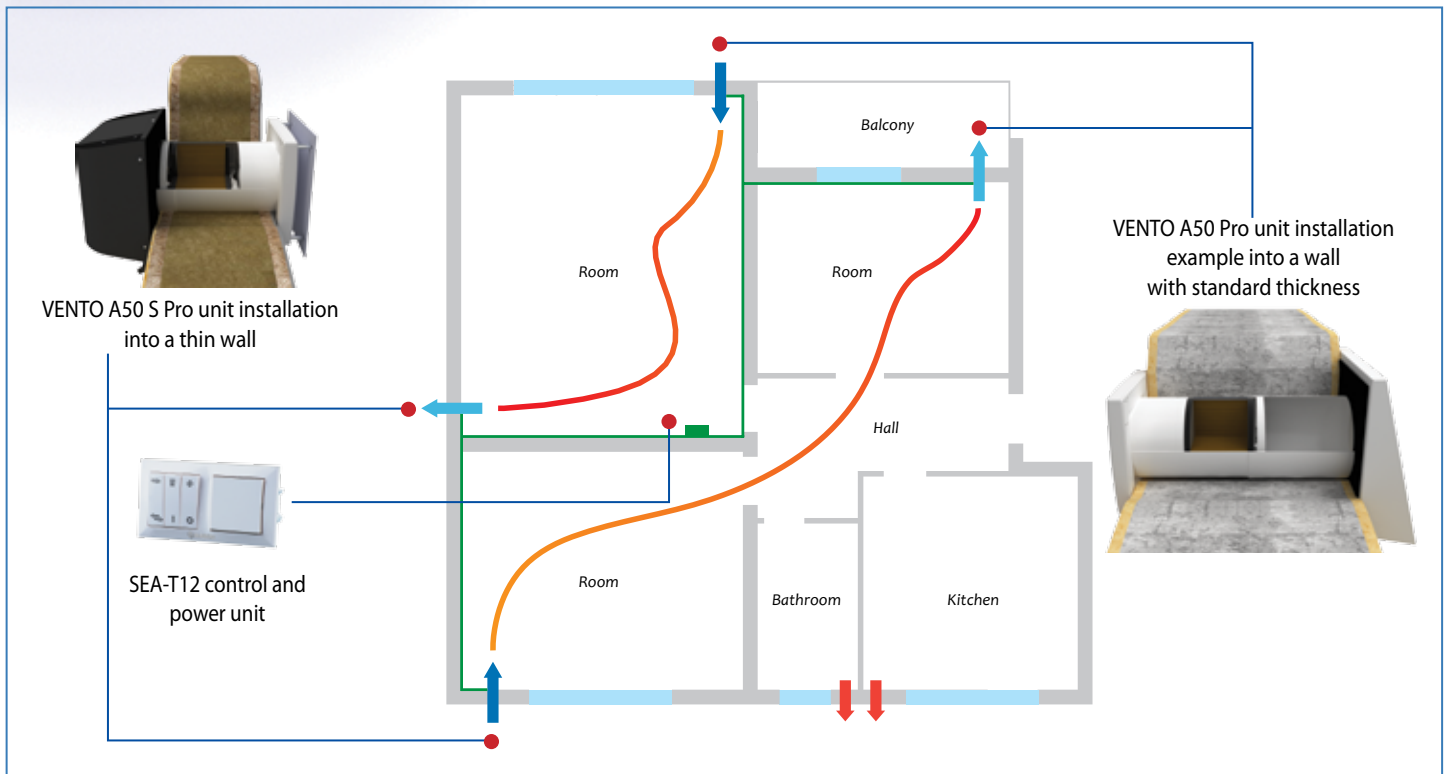

■ Technical data



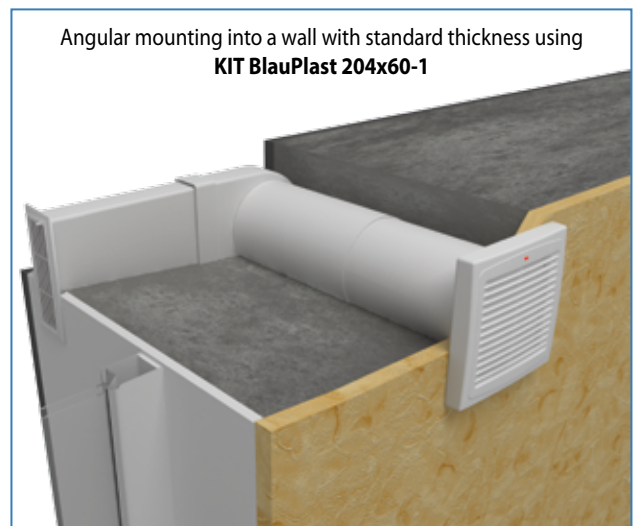

Parameters	VENTO A50 / VENTO A50-1 VENTO A50 S / VENTO A50-1 S	
	1	2
Speed	1	2
Voltage / 50 Hz [V]	220-240	
Power [W]	3.68	4.83
Current [A]	0.021	0.026
RPM [min ⁻¹]	599	1155
Air capacity [m ³ /h]	26	53
Sound pressure level at 1 m [dB(A)]	24	34
Sound pressure level at 3 m [dB(A)]	14	24
Outdoor sound pressure attenuation [dB(A)]	18	
Regeneration efficiency [%]	up to 90	
SEC class	A	
Ingress protection rating	IP 24	

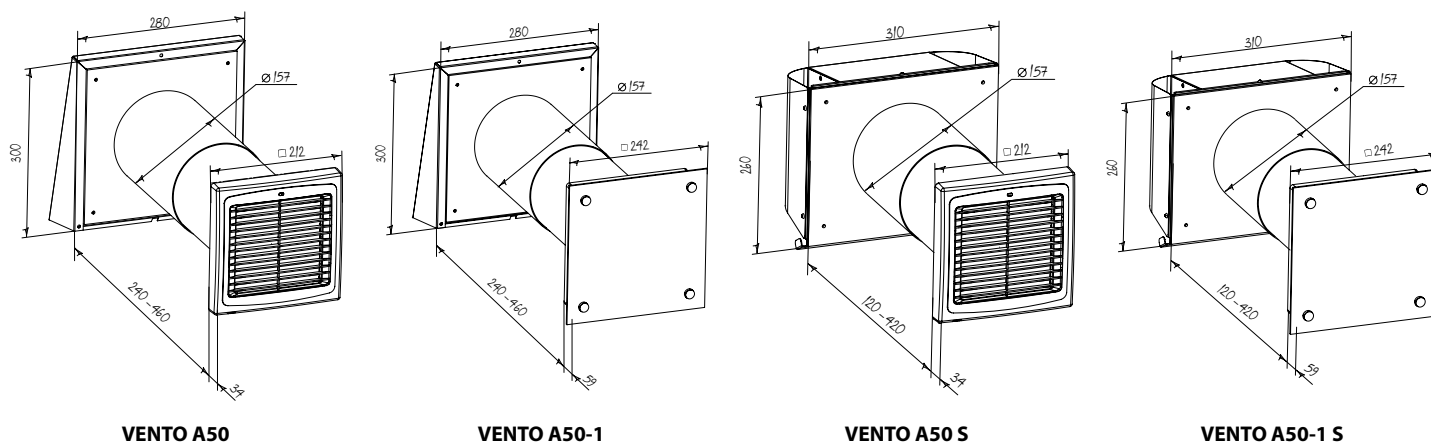

Overall dimensions



Accessories

Accessory name	Description
 SEA-T12 (230/12) control and power unit  SEA control unit	<ul style="list-style-type: none"> <input type="checkbox"/> SEA-T12 is an external control unit with a 12 W power transformer. It is included into VENTO A50 / A50-1 Pro and VENTO A50 / A50-1 S Pro units standard delivery set. <input type="checkbox"/> SEA is an external control unit for the unit operation mode control.
 AT-40 (230/12) power transformer  AT-12 (230/12) power transformer	<ul style="list-style-type: none"> <input type="checkbox"/> AT-40 is a 40 W power transformer for synchronous connection of 12 units. Used jointly with SEA control unit it ensures a central controllable ventilation system. <input type="checkbox"/> AT-12 is a 12 W power transformer for synchronous connection of 4 units. Used jointly with SEA control unit it ensures a central controllable ventilation system.
Pre-installation kit for mounting into a wall with standard thickness Pre-installation Kit VENTO A50	<ul style="list-style-type: none"> <input type="checkbox"/> Includes: <ul style="list-style-type: none"> • Round Ø150 mm air duct, 240 up to 460 mm long. • AH 150 outer ventilation hood. • Plastic foam plug.
Pre-installation kit for mounting into a thin wall Pre-installation Kit VENTO A50 S	<ul style="list-style-type: none"> <input type="checkbox"/> Includes: <ul style="list-style-type: none"> • Round Ø150 mm air duct, 120 up to 420 mm long. • AH-S 150 outer ventilation hood. • Plastic foam plug.
Final mounting kit Completion Kit VENTO A50	<ul style="list-style-type: none"> <input type="checkbox"/> Includes: <ul style="list-style-type: none"> • Ceramic regenerator Ø150 mm. • VENTO A50 ventilation unit. • G3 filters.
Final mounting kit Completion Kit VENTO A50-1	<ul style="list-style-type: none"> <input type="checkbox"/> Includes: <ul style="list-style-type: none"> • Ceramic regenerator Ø150 mm. • VENTO A50-1 ventilation unit. • G3 filters.
Mounting kit for angular installation in walls with standard thickness KIT BlauPlast 204x60-1	<ul style="list-style-type: none"> <input type="checkbox"/> Includes: <ul style="list-style-type: none"> • Plastic ventilation grille 230x86 mm. • Plastic air duct 204x60 mm. • Plastic connecting bend from Ø150 to 204x60 mm.