

HEAT RECOVERY SINGLE-ROOM UNITS



VENTO Ergo A50 Pro VENTO Ergo A50-1 Pro

Air capacity – up to 50 m³/h
Heat recovery – up to 88 %



Use

- Arrangement of efficient energy-saving supply and exhaust single-room ventilation in flats, houses, cottages, social and commercial premises.
- Heat recovery minimises ventilation heat losses.
- Humidity balance and controllable air exchange create individually set microclimate.
- Coordinated network based on several integrated single-room ventilation units with central control.

Design

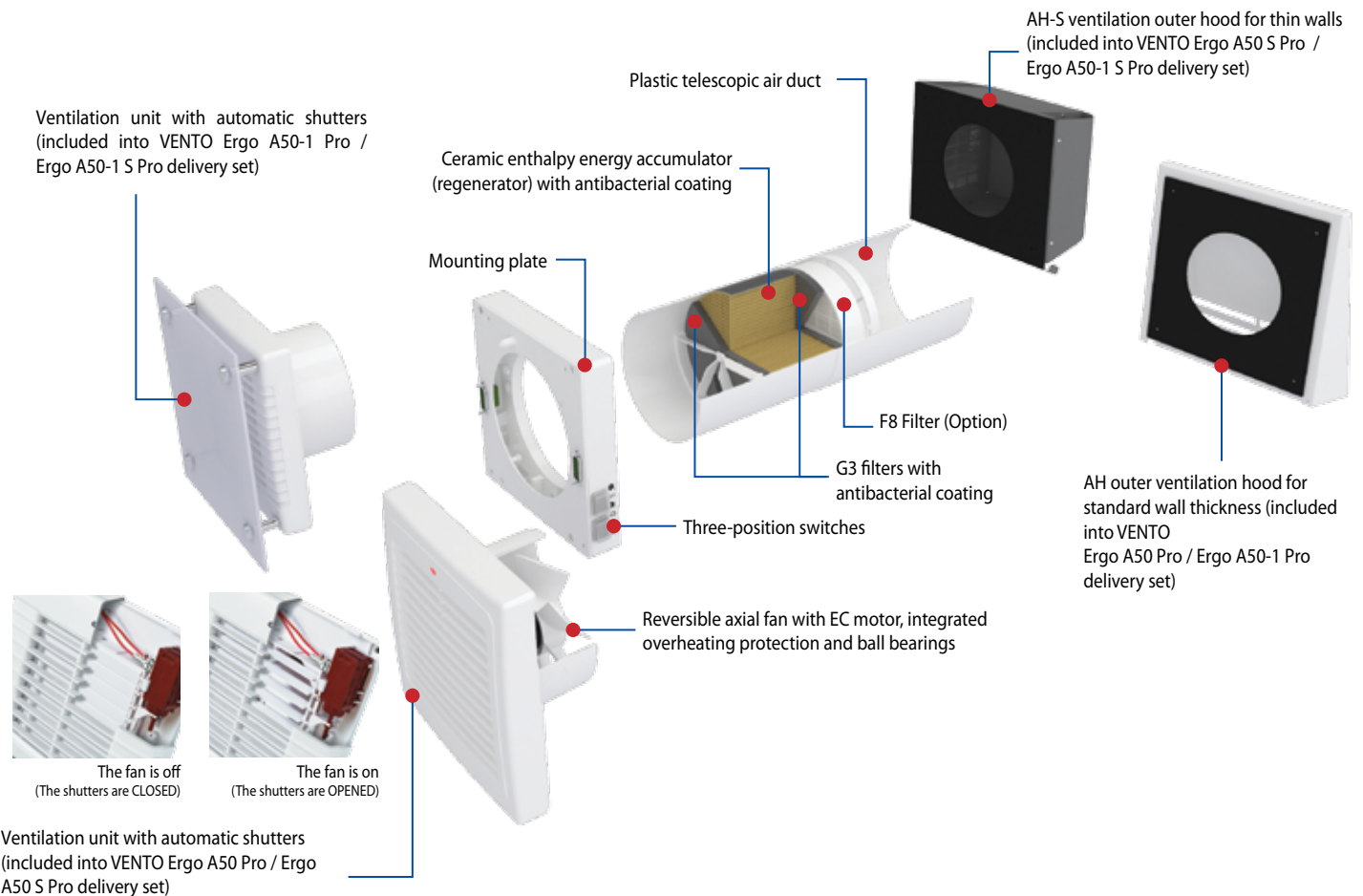

Heat and moisture regeneration

- High-tech ceramic energy accumulator with heat recovery up to 88 %.
- Due to its cellular structure it has a larger heat transfer area surface and high efficiency. The energy accumulator is featured with excellent heat-conducting properties and thermal energy storage capacity.

Modifications:

- VENTO Ergo A50-1 Pro – without a power cord
- VENTO Ergo A50-1 Pro P – white power cord with Euro plug
- VENTO Ergo A50-1 Pro P1 – white power cord with USA plug
- VENTO Ergo A50-1 Pro P2 – white power cord with British plug

Unit operating logic in winter period

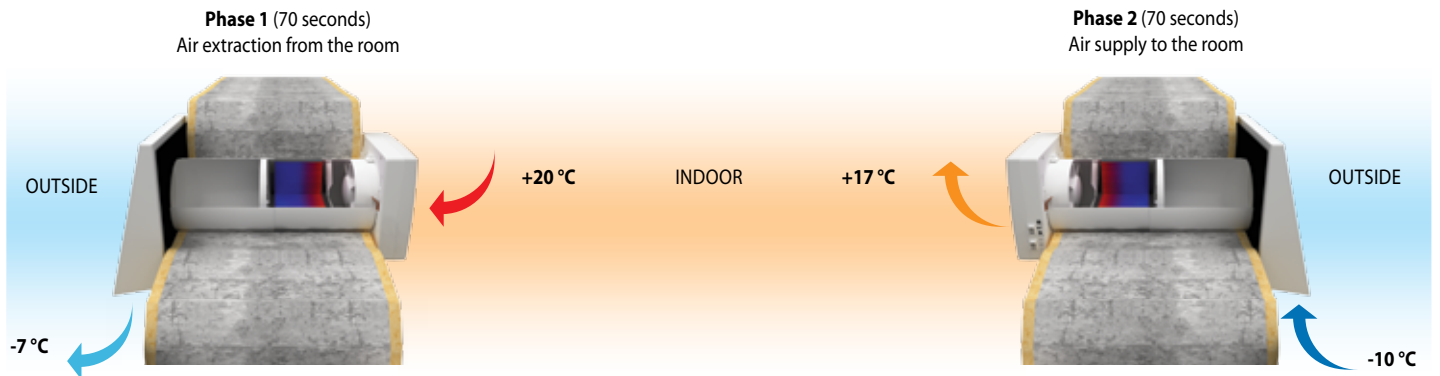

- Warm stale air is extracted from the premise, flows through the ceramic regenerator and transfers a part of the accumulated heat and moisture to it.
- In 70 seconds, after heating of the ceramic regenerator, the unit switches to the supply mode.
- Clean cold intake air flows through the regenerator and absorbs accumulated heat and humidity.
- In 70 seconds, after cooling of the ceramic regenerator, the unit is switched to the extract air mode.

Control

- The unit operation mode control is performed by means of manual three-position switches located on the unit casing or using the remote controller.
- The unit is equipped with a humidity sensor for indoor humidity control and regulation.
- Connection of the units into one ventilation system provide balanced ventilation and central control.

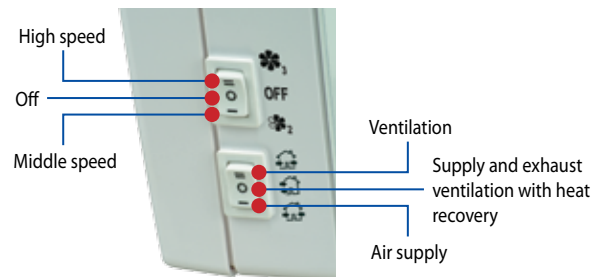

□ Remote control and operation mode selection:

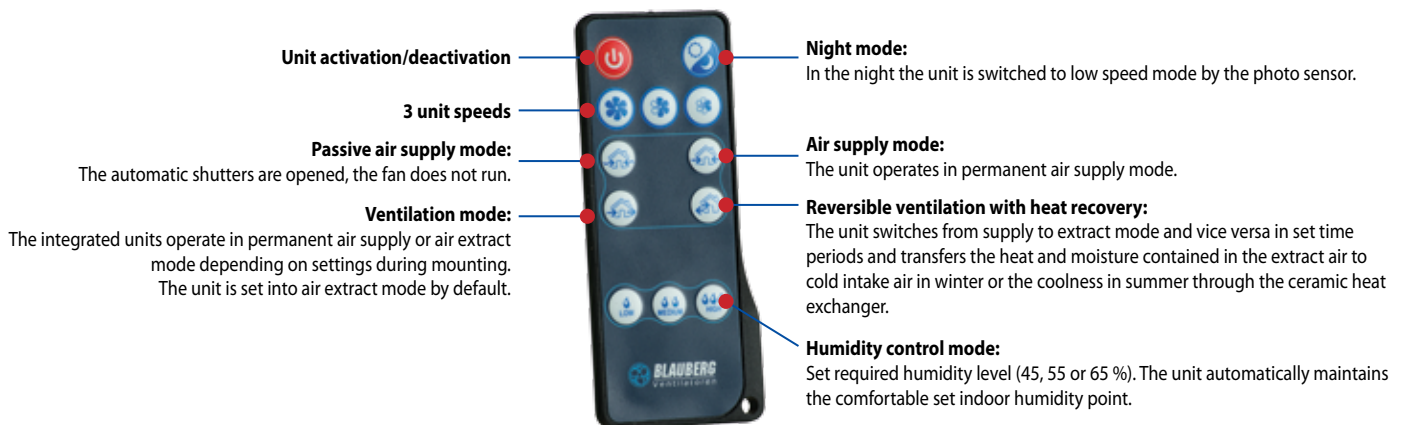

- Unit activation/deactivation:** Power button.
- 3 unit speeds:** Three buttons for speed selection.
- Passive air supply mode:** The automatic shutters are opened, the fan does not run.
- Ventilation mode:** The integrated units operate in permanent air supply or air extract mode depending on settings during mounting. The unit is set into air extract mode by default.
- Night mode:** In the night the unit is switched to low speed mode by the photo sensor.
- Air supply mode:** The unit operates in permanent air supply mode.
- Reversible ventilation with heat recovery:** The unit switches from supply to extract mode and vice versa in set time periods and transfers the heat and moisture contained in the extract air to cold intake air in winter or the coolness in summer through the ceramic heat exchanger.
- Humidity control mode:** Set required humidity level (45, 55 or 65 %). The unit automatically maintains the comfortable set indoor humidity point.

□ Connection of several units in series enables their synchronous control by the first unit. The signal from the remote control is received by the first unit only.

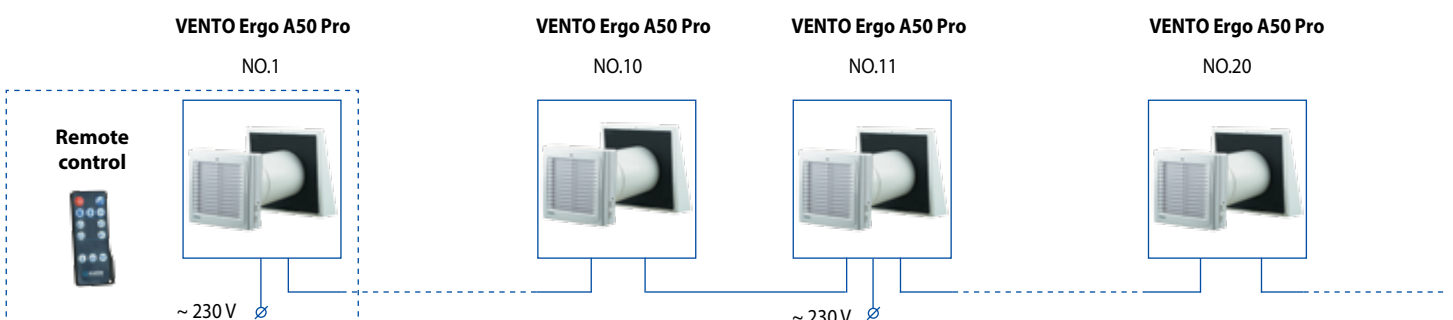

HEAT RECOVERY SINGLE-ROOM UNITS

■ Mounting

- The unit is designed for external through-the-wall installation inside a prepared round hole in the outer wall of the building.
- The best ventilation solution is pairwise installation of reverse phase connected units. Some units supply fresh air to the room and the other units extract stale air from the room. This allows to arrange the most efficient balanced ventilation.
- In case of brand new construction the units are mounted in two stages:
 - **pre-installation** at the stage of the indoor finishing and outer decorative wall

finishing. It includes installation of the telescopic air ducts, outer ventilation hood and laying out of electric cables.

- **final mounting** before commissioning of a house. It includes installation of the regenerator, the filters, connection of the ventilation unit.
- If mounting of the ventilation hood on the outer wall is undesirable it may be flush mounted and the external grille may be inserted into the outer window jamb using the KIT BlauPlast 204x60-1 pre-installation kit. Available upon separate order.

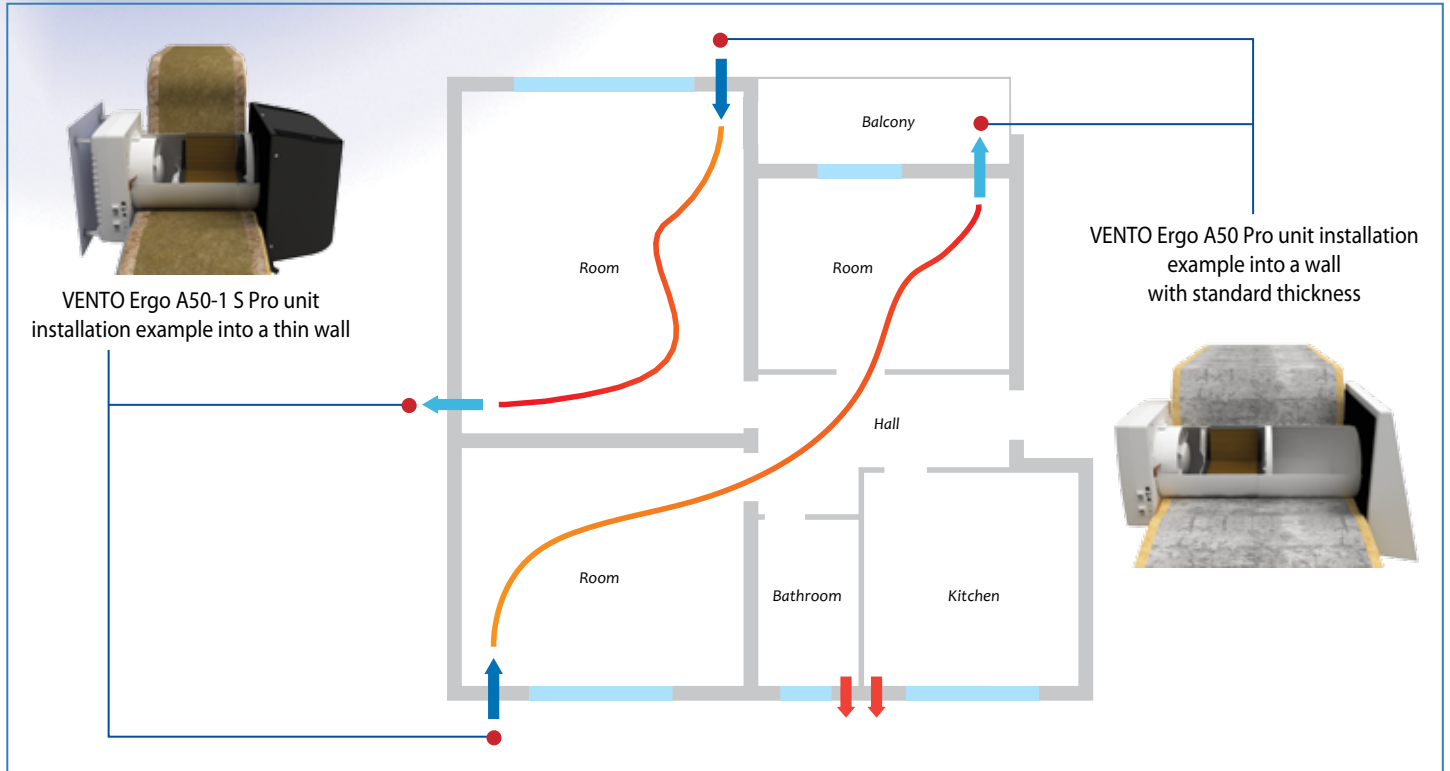

■ Technical data

Parameters	VENTO Ergo A50 Pro / Ergo A50-1 Pro VENTO Ergo A50 S Pro / Ergo A50-1 S Pro		
	1	2	3
Speed	1	2	3
Voltage / 50-60 Hz [V]	1 ~ 100-230		
Power [W]	4.5	5	7
Current [A]	0.024	0.026	0.039
RPM [min ⁻¹]	610	800	1450
Air capacity [m ³ /h]	21	32	50
Sound pressure level at 1 m [dB(A)] *	22	29	32
Sound pressure level at 3 m [dB(A)] *	13	20	23
Outdoor sound pressure attenuation [dB(A)] **	40		
Regeneration efficiency [%] ***	88	83	75
Maximum transported air temperature, °C	from -20 to +50		
SEC class	A		
Ingress protection rating	IP24		

Angular mounting into a wall with standard thickness using **KIT BlauPlast 204x60-1**

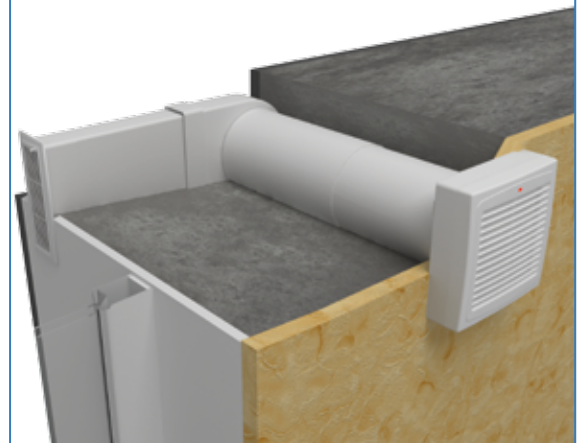

* In accordance with ISO 3741: 2004

** In accordance with DIN EN 20140

*** In accordance with DIBt LÜ-A 20

Overall dimensions, mm

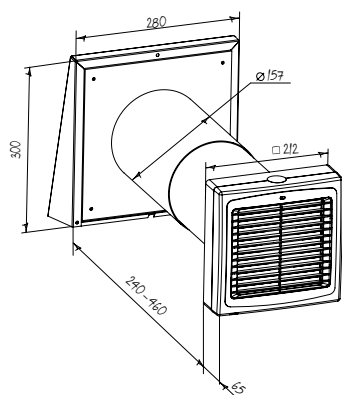

VENTO Ergo A50 Pro

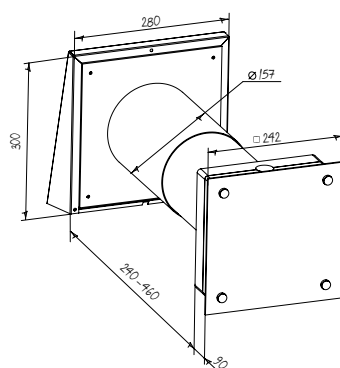

VENTO Ergo A50-1 Pro

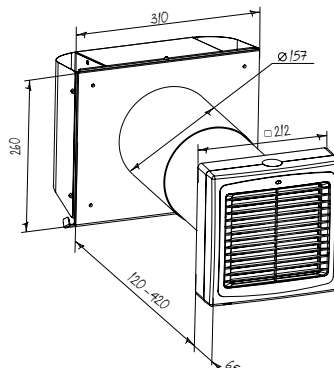

VENTO Ergo A50 S Pro

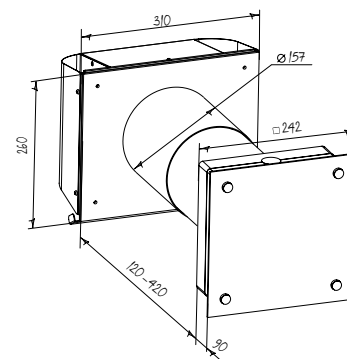

VENTO Ergo A50-1 S Pro

Accessories

Accessory name	Description
Pre-installation Kit VENTO Ergo A50 Pro	<input type="checkbox"/> Includes: <ul style="list-style-type: none"> • Round Ø150 mm air duct • AH 150 outer ventilation hood • Plastic foam plug
Completion Kit VENTO Ergo A50 Pro	<input type="checkbox"/> Includes: <ul style="list-style-type: none"> • Ceramic regenerator Ø150 mm • VENTO Ergo A50 ventilation unit • G3 filters • Mounting plate • Remote control
Completion Kit VENTO Ergo A50-1 Pro	<input type="checkbox"/> Includes: <ul style="list-style-type: none"> • Ceramic regenerator Ø150 mm • VENTO Ergo A50-1 ventilation unit • G3 filters • Mounting plate • Remote control
FB-Vento Ergo	<input type="checkbox"/> Remote control
KIT BlauPlast 204x60-1	Installation kit for angular mounting <input type="checkbox"/> Includes: <ul style="list-style-type: none"> • Plastic ventilation grille 230x86 mm • Plastic air duct 204x60 mm • Plastic connecting bend from Ø150 to 204x60 mm
FP VENTO Ergo A50 G3	<input type="checkbox"/> G3 filter kit (2 pcs)
FP VENTO Ergo A50 F8	<input type="checkbox"/> F8 filter (1 pc)
AH white 150	<input type="checkbox"/> White painted aluminium hood
AH chrome 150	<input type="checkbox"/> Brushed stainless steel hood
AH-S grey 150	<input type="checkbox"/> Grey painted stainless steel hood for thin walls
AH-S chrome 150	<input type="checkbox"/> Brushed stainless steel hood for thin walls