

# WKH

## Duct water heaters for rectangular ducts

### Use

- For warming up of supply air in ventilation systems installed in various premises.
- Suitable for installation in supply or air handling units to warm up the supply air flow.
- For indoor use only if water serves as a heat carrier.
- For outdoor use antifreezing mixture (ethylene glycol solution).
- Compatible with 400x200 up to 1000x500 mm rectangular air ducts.

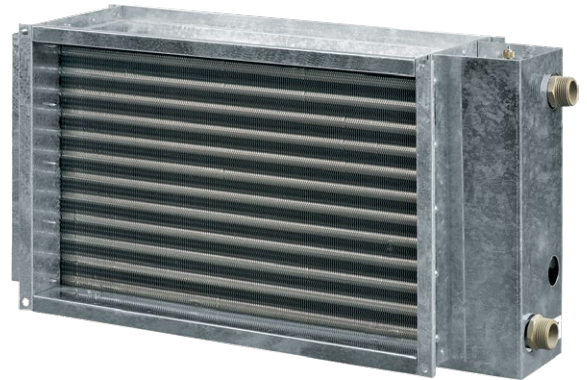

### Design

- Galvanized steel case.
- Copper pipe manifold.
- Heat exchange surface made of aluminium plates.
- Equipped with a nipple for the system deaeration.
- Outlet header is equipped with a spigot for installation of an immersion temperature sensor or freezing protection mechanism.
- Available in two, three- or four-row tube modifications.
- Suitable for operation at maximum operating pressure 1.6 MPa (16 bar) and maximum transported air temperature +100 °C.

### Mounting

- Fixing to rectangular ducts with flange connection.
- Any mounting position that ensures the heater deaeration.
- Install a filter upstream to the heater to protect heating elements against dirt ingress.
- Install the heater in front or behind the fan. In case of mounting behind the fan ensure the distance no less than 1-1.5 m for air flow stabilization and keep the maximum permissible air temperature inside the fan.
- Connect the heater on counter-flow basis, otherwise its capacity drops by 5-15 %. All the nomographic charts are rated for counter-flow connection.
- For correct and safe heater operation an automatic control and protection system is recommended, including the following functions:
  - regulation of the heating capacity and temperature of the air heated up;
  - filter clogging control by a differential air pressure sensor;
  - ventilation system start-up with pre-heated heater;
  - use of air dampers with a servo actuator with a return spring;
  - fan turning off in case of the heater freezing danger.

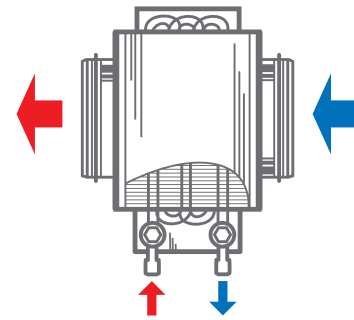

Connection against air flow

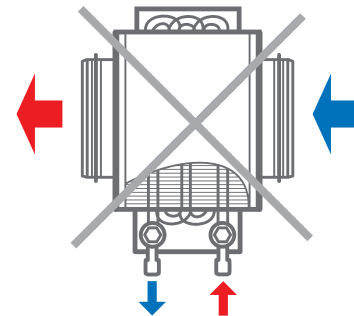

Connection along air flow

#### Designation key

Series	Flange size (WxH) [cm]	Number of water (glycol) coil rows
WKH	40x20; 50x25; 50x30; 60x30; 60x35; 70x40; 80x50; 90x50; 100x50	- 2; 3; 4

**Overall dimensions [mm]**

Model	B	B1	B2	B3	H	H1	H2	H3	L	L1	L2	K	Number of water coil rows	Weight [kg]
WKH 40x20-2	400	420	440	565	200	220	240	150	200	43	43	G 3/4"	2	7.6
WKH 40x20-4	400	420	440	565	200	220	240	150	200	38	65	G 3/4"	4	8.1
WKH 50x25-2	500	520	540	665	250	270	290	200	200	43	43	G 3/4"	2	15.8
WKH 50x25-4	500	520	540	665	250	270	290	200	200	38	65	G 3/4"	4	16.3
WKH 50x30-2	500	520	540	665	300	320	340	250	200	43	43	G 1"	2	11.5
WKH 50x30-4	500	520	540	665	300	320	340	250	200	38	65	G 1"	4	12.0
WKH 60x30-2	600	620	640	765	300	320	340	250	200	43	43	G 1"	2	21.8
WKH 60x30-4	600	620	640	765	300	320	340	250	200	38	65	G 1"	4	22.3
WKH 60x35-2	600	620	640	765	350	370	390	300	200	43	43	G 1"	2	22.4
WKH 60x35-4	600	620	640	765	350	370	390	300	200	38	65	G 1"	4	22.9
WKH 70x40-2	700	720	740	865	400	420	440	350	200	36	47	G 1"	2	27.8
WKH 70x40-3	700	720	740	865	400	420	440	350	200	42	58	G 1"	3	28.4
WKH 80x50-2	800	820	840	965	500	520	540	450	200	36	47	G 1"	2	36.5
WKH 80x50-3	800	820	840	965	500	520	540	450	200	42	58	G 1"	3	37.2
WKH 90x50-2	900	920	940	1065	500	520	540	450	200	36	47	G 1"	2	40.4
WKH 90x50-3	900	920	940	1065	500	520	540	450	200	42	58	G 1"	3	41.2
WKH 100x50-2	1000	1020	1040	1165	500	520	540	450	200	36	47	G 1"	2	44.3
WKH 100x50-3	1000	1020	1040	1165	500	520	540	450	200	42	58	G 1"	3	45.2

**AIR PRESSURE LOSS FOR WATER HEATERS WKH**

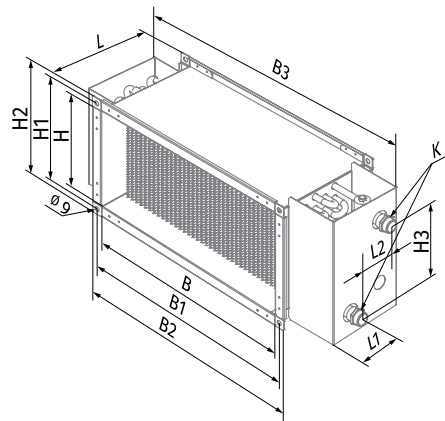
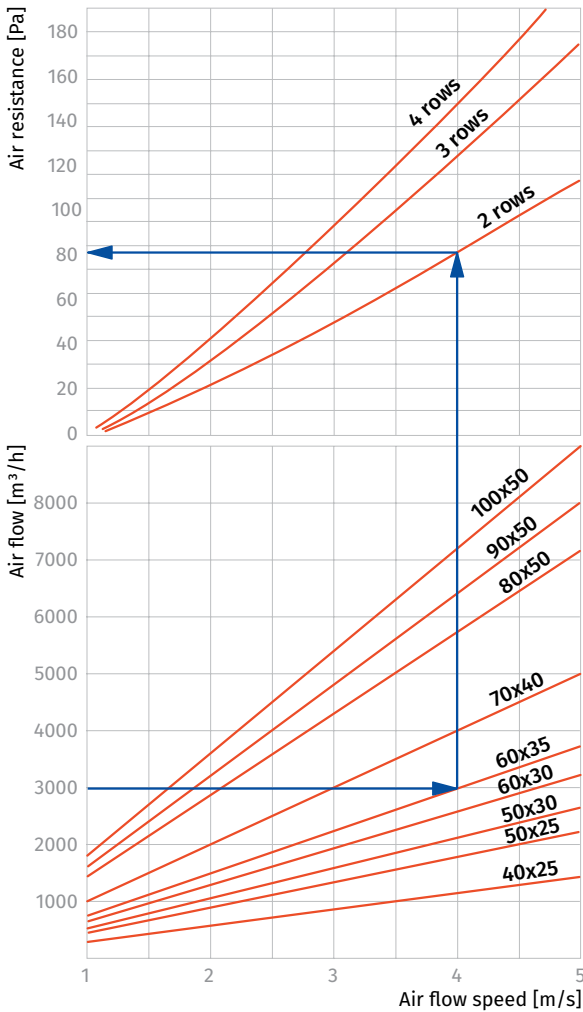

HEATERS

**Water heaters calculation diagram**

**WKH 40x20-2**

Air temperature downstream of the water heating coils [°C]

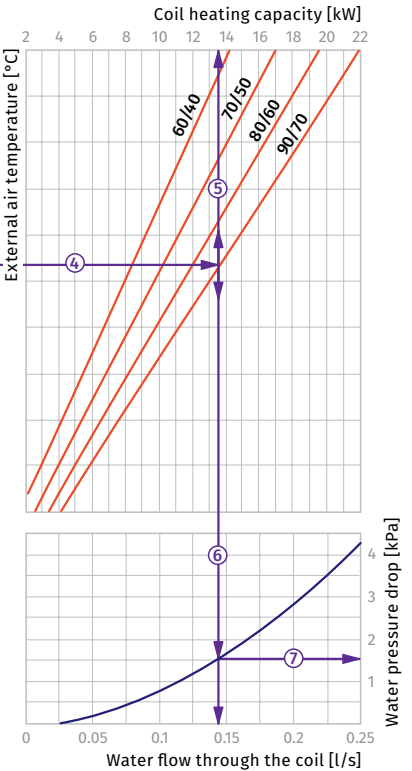
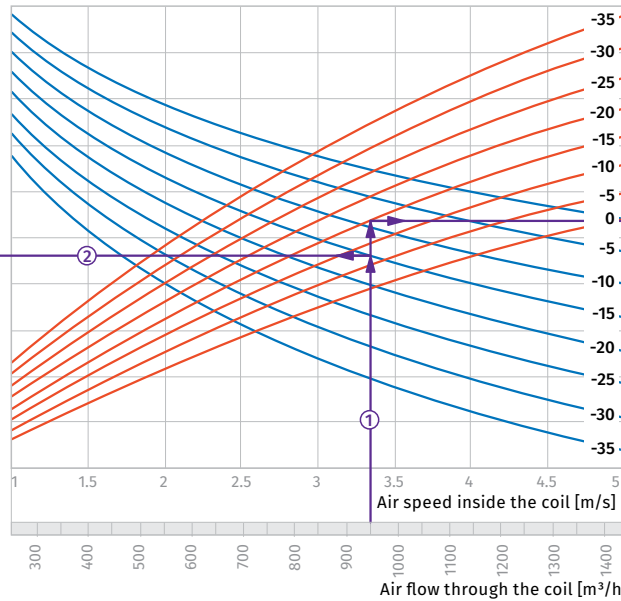
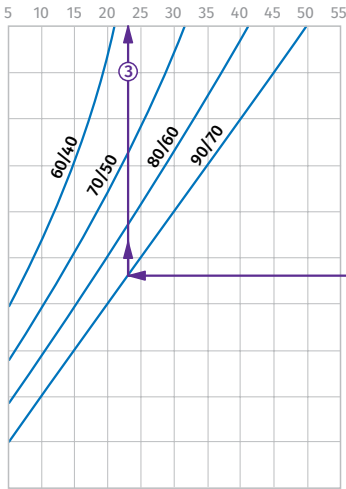

**How to use water heater diagrams.**

System Parameters: Air flow = 950 m<sup>3</sup>/h.  
Outside air temperature = -15 °C.  
Water temperature (in/out) = +90/+70 °C.  
The air flow is 950 m<sup>3</sup>/h and the air speed in the heater is 3.35 m/s ①.

- To calculate the maximum air temperature find the intersection point of the air flow line ① with the rated outer temperature shown in blue line (e.g., -15 °C) and draw the line ② to the left until it crosses the water in/out temperature curve (e.g., +90/+70). From this point draw a vertical line to the supply air temperature downstream of the heater (+23 °C) ③.

- To calculate the heater power find the intersection point of the air flow ① with the rated winter temperature shown in red line (e.g., -15 °C) and draw the line ④ to the right until it crosses the water in/out temperature curve (e.g., +90/+70). From this point draw a vertical line to the heater power axis (13.5 kW) ⑤.

- To calculate the required water flow in the heater prolong this line ⑥ downwards to the water flow axis (0.14 l/s).
- To calculate the water pressure drop in the heater find the intersection point of the line ⑥ with the pressure loss curve and prolong the line ⑦ to the right on the water pressure drop axis (1.5 kPa).

**WKH 40x20-4**

Air temperature downstream of the water heating coils [°C]

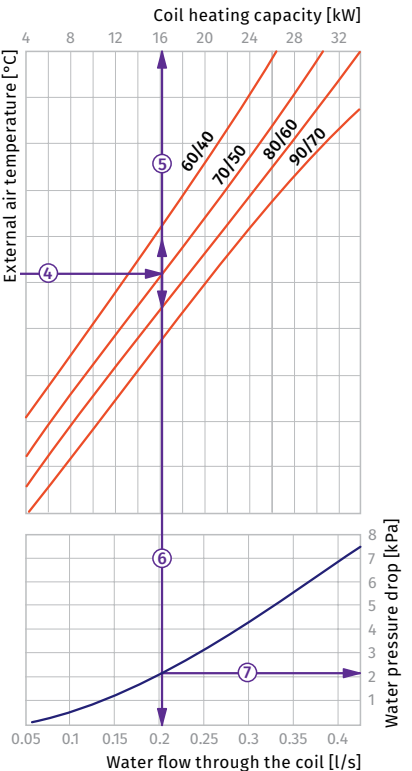
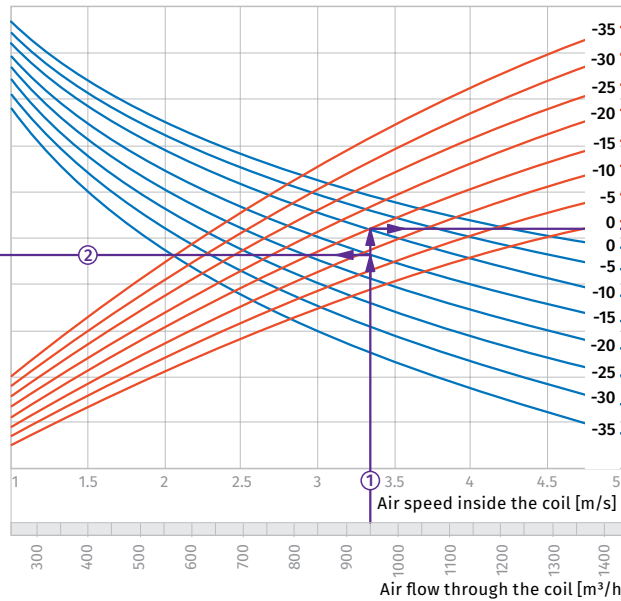
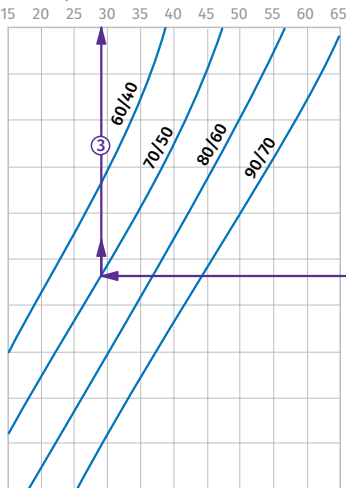

**How to use water heater diagrams.**

System Parameters: Air flow = 250 m<sup>3</sup>/h.  
Outside air temperature = -15 °C.  
Water temperature (in/out) = +70/+50 °C.  
The air flow is 250 m<sup>3</sup>/h and the air speed in the heater is 3.35 m/s ①.

- To calculate the maximum air temperature find the intersection point of the air flow line ① with the rated outer temperature shown in blue line (e.g., -15 °C) and draw the line ② to the left until it crosses the water in/out temperature curve (e.g., +70/+50). From this point draw a vertical line to the supply air temperature downstream of the heater (+29 °C) ③.

- To calculate the heater power find the intersection point of the air flow ① with the rated winter temperature shown in red line (e.g., -15 °C) and draw the line ④ to the right until it crosses the water in/out temperature curve (e.g., +70/+50). From this point draw a vertical line to the heater power axis (16.0 kW) ⑤.

- To calculate the required water flow in the heater prolong this line ⑥ downwards to the water flow axis (0.2 l/s).
- To calculate the water pressure drop in the heater find the intersection point of the line ⑥ with the pressure loss curve and prolong the line ⑦ to the right on the water pressure drop axis (2.1 kPa).

**WKH 50x25-2**

Air temperature downstream of the water heating coils [°C]

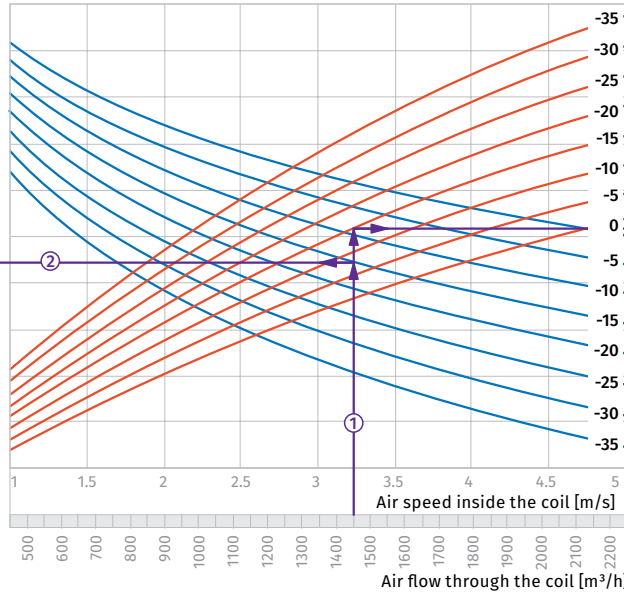
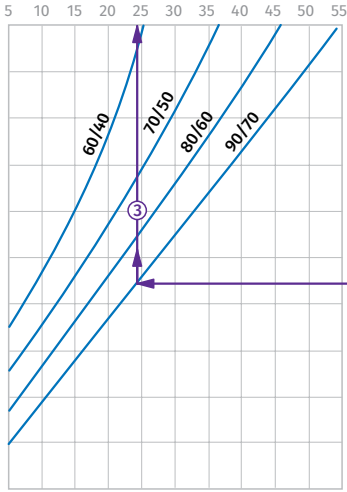

Coil heating capacity [kW]

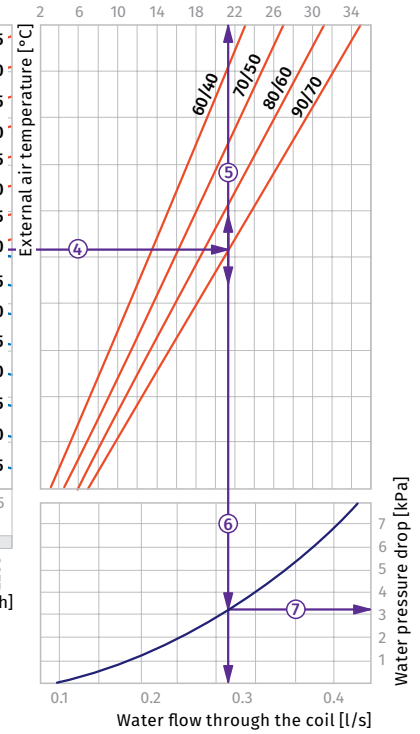

**How to use water heater diagrams.**

System Parameters: Air flow = 1450 m³/h.  
Outside air temperature = -15 °C.  
Water temperature (in/out) = +90/+70 °C.  
The air flow is 1450 m³/h and the air speed in the heater is 3.2 m/s ①.

- To calculate the maximum air temperature find the intersection point of the air flow line ① with the rated outer temperature shown in blue line (e.g., -15 °C) and draw the line ② to the left until it crosses the water in/out temperature curve (e.g., +90/+70). From this point draw a vertical line to the supply air temperature downstream of the heater (+24 °C) ③.

- To calculate the heater power find the intersection point of the air flow ① with the rated winter temperature shown in red line (e.g., -15 °C) and draw the line ④ to the right until it crosses the water in/out temperature curve (e.g., +90/+70). From this point draw a vertical line to the heater power axis (21.5 kW) ⑤.

- To calculate the required water flow in the heater prolong this line ⑥ downwards to the water flow axis (0.27 l/s).
- To calculate the water pressure drop in the heater find the intersection point of the line ⑥ with the pressure loss curve and prolong the line ⑦ to the right on the water pressure drop axis (3.2 kPa).

**WKH 50x30-4**

Air temperature downstream of the water heating coils [°C]

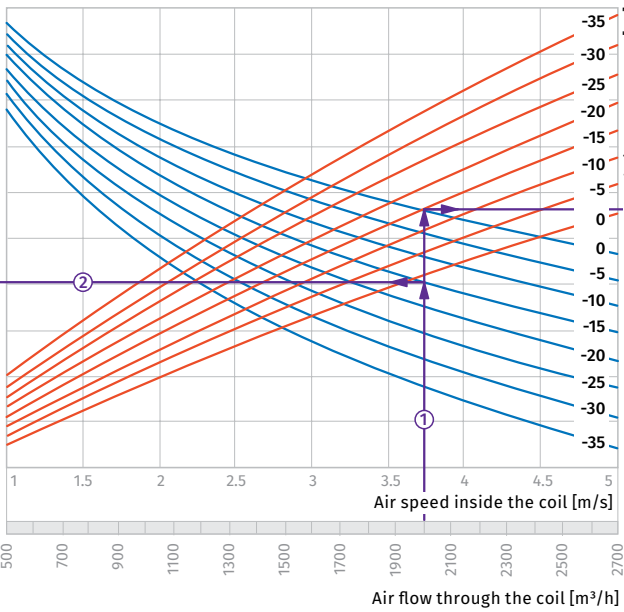
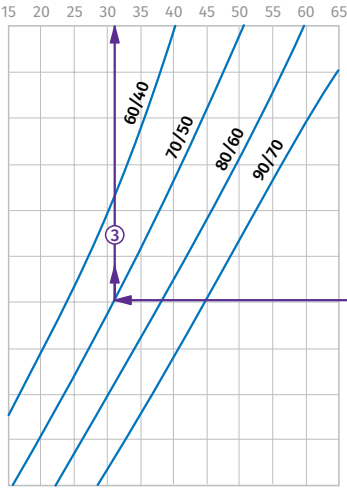

Coil heating capacity [kW]

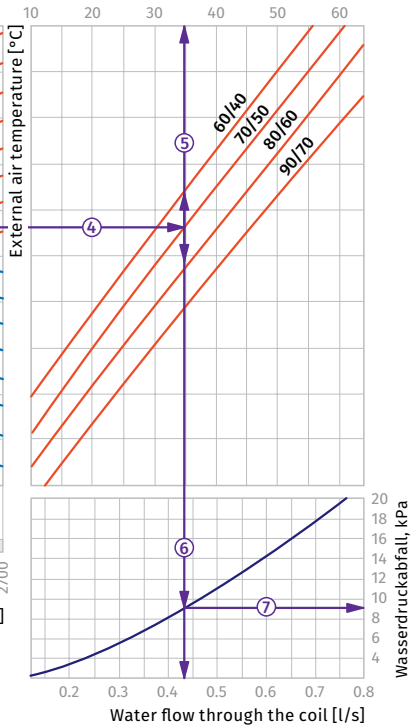

**How to use water heater diagrams.**

System Parameters: Air flow = 2000 m³/h.  
Outside air temperature = -15 °C.  
Water temperature (in/out) = +70/+50 °C.  
The air flow is 2000 m³/h and the air speed in the heater is 3.75 m/s ①.

- To calculate the maximum air temperature find the intersection point of the air flow line ① with the rated outer temperature shown in blue line (e.g., -15 °C) and draw the line ② to the left until it crosses the water in/out temperature curve (e.g., +70/+50). From this point draw a vertical line to the supply air temperature downstream of the heater (+31 °C) ③.

- To calculate the heater power find the intersection point of the air flow ① with the rated winter temperature shown in red line (e.g., -15 °C) and draw the line ④ to the right until it crosses the water in/out temperature curve (e.g., +70/+50). From this point draw a vertical line to the heater power axis (35.0 kW) ⑤.

- To calculate the required water flow in the heater prolong this line ⑥ downwards to the water flow axis (0.43 l/s).
- To calculate the water pressure drop in the heater find the intersection point of the line ⑥ with the pressure loss curve and prolong the line ⑦ to the right on the water pressure drop axis (9.0 kPa).

**WKH 60x30-2**

Air temperature downstream of the water heating coils [°C]

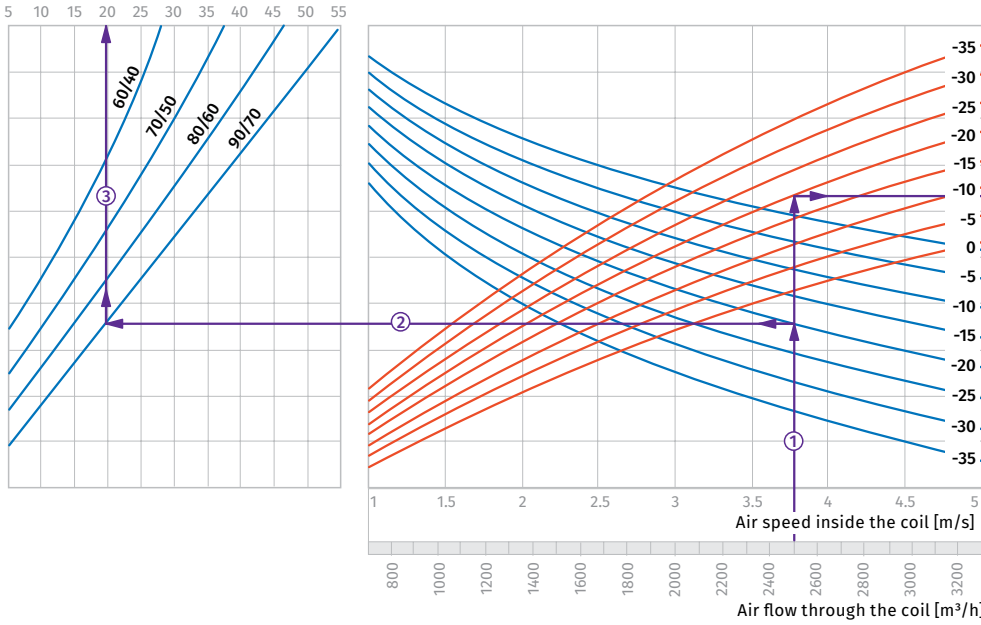

**How to use water heater diagrams.**

System Parameters: Air flow = 2500 m³/h.  
Outside air temperature = -20 °C.  
Water temperature (in/out) = +90/+70 °C.  
The air flow is 2500 m³/h and the air speed in the heater is 3.75 m/s ①.

- To calculate the maximum air temperature find the intersection point of the air flow line ① with the rated outer temperature shown in blue line (e.g., -20 °C) and draw the line ② to the left until it crosses the water in/out temperature curve (e.g., +90/+70). From this point draw a vertical line to the supply air temperature downstream of the heater (+20 °C) ③.

- To calculate the heater power find the intersection point of the air flow ① with the rated winter temperature shown in red line (e.g., -20 °C) and draw the line ④ to the right until it crosses the water in/out temperature curve (e.g., +90/+70). From this point draw a vertical line to the heater power axis (37.0 kW) ⑤.

- To calculate the required water flow in the heater prolong this line ⑥ downwards to the water flow axis (0.46 l/s).
- To calculate the water pressure drop in the heater find the intersection point of the line ⑥ with the pressure loss curve and prolong the line ⑦ to the right on the water pressure drop axis (6.7 kPa).

**WKH 60x30-4**

Air temperature downstream of the water heating coils [°C]

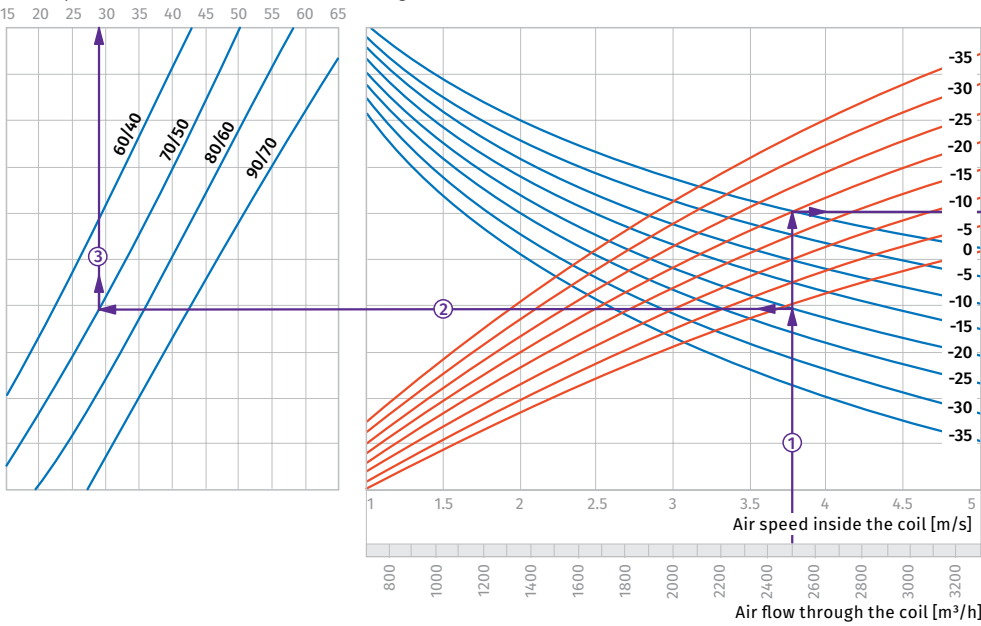

**How to use water heater diagrams.**

System Parameters: Air flow = 2500 m³/h.  
Outside air temperature = -20 °C.  
Water temperature (in/out) = +70/+50 °C.  
The air flow is 2500 m³/h and the air speed in the heater is 3.75 m/s ①.

- To calculate the maximum air temperature find the intersection point of the air flow line ① with the rated outer temperature shown in blue line (e.g., -20 °C) and draw the line ② to the left until it crosses the water in/out temperature curve (e.g., +70/+50). From this point draw a vertical line to the supply air temperature downstream of the heater (+29 °C) ③.

- To calculate the heater power find the intersection point of the air flow ① with the rated winter temperature shown in red line (e.g., -20 °C) and draw the line ④ to the right until it crosses the water in/out temperature curve (e.g., +70/+50). From this point draw a vertical line to the heater power axis (48.0 kW) ⑤.

- To calculate the required water flow in the heater prolong this line ⑥ downwards to the water flow axis (0.6 l/s).
- To calculate the water pressure drop in the heater find the intersection point of the line ⑥ with the pressure loss curve and prolong the line ⑦ to the right on the water pressure drop axis (14.0 kPa).

**WKH 60x35-2**

Air temperature downstream of the water heating coils [°C]

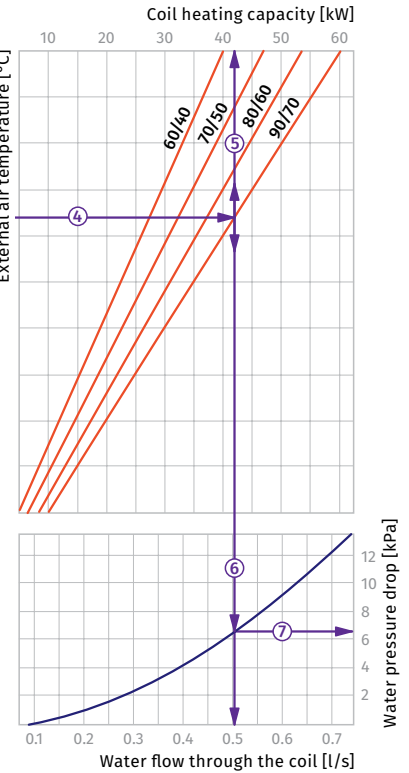
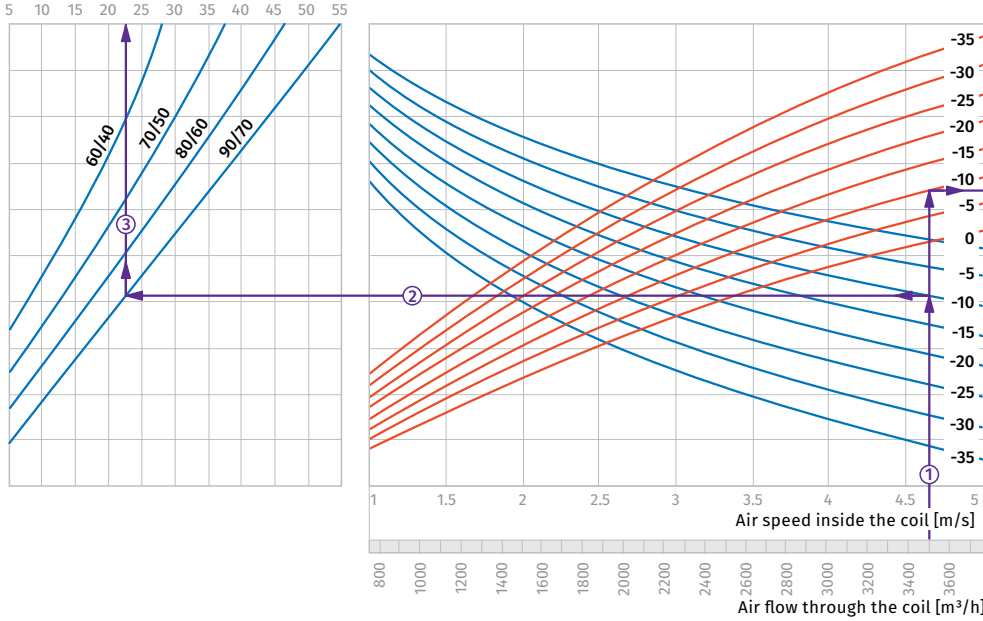

**How to use water heater diagrams.**

System Parameters: Air flow = 3500 m³/h.  
 Outside air temperature = -10 °C.  
 Water temperature (in/out) = +90/+70 °C.  
 The air flow is 2500 m³/h and the air speed in the heater is 4.65 m/s ①.

- To calculate the maximum air temperature find the intersection point of the air flow line ① with the rated outer temperature shown in blue line (e.g., -10 °C) and draw the line ② to the left until it crosses the water in/out temperature curve (e.g., +90/+70). From this point draw a vertical line to the supply air temperature downstream of the heater (+22.5 °C) ③.

- To calculate the heater power find the intersection point of the air flow ① with the rated winter temperature shown in red line (e.g., -10 °C) and draw the line ④ to the right until it crosses the water in/out temperature curve (e.g., +90/+70). From this point draw a vertical line to the heater power axis (42.0 kW) ⑤.

- To calculate the required water flow in the heater prolong this line ⑥ downwards to the water flow axis (0.5 l/s).
- To calculate the water pressure drop in the heater find the intersection point of the line ⑥ with the pressure loss curve and prolong the line ⑦ to the right on the water pressure drop axis (6.5 kPa).

**WKH 60x35-4**

Air temperature downstream of the water heating coils [°C]

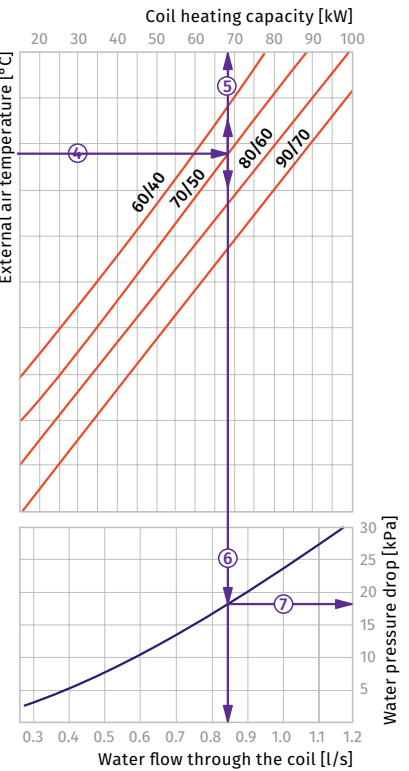
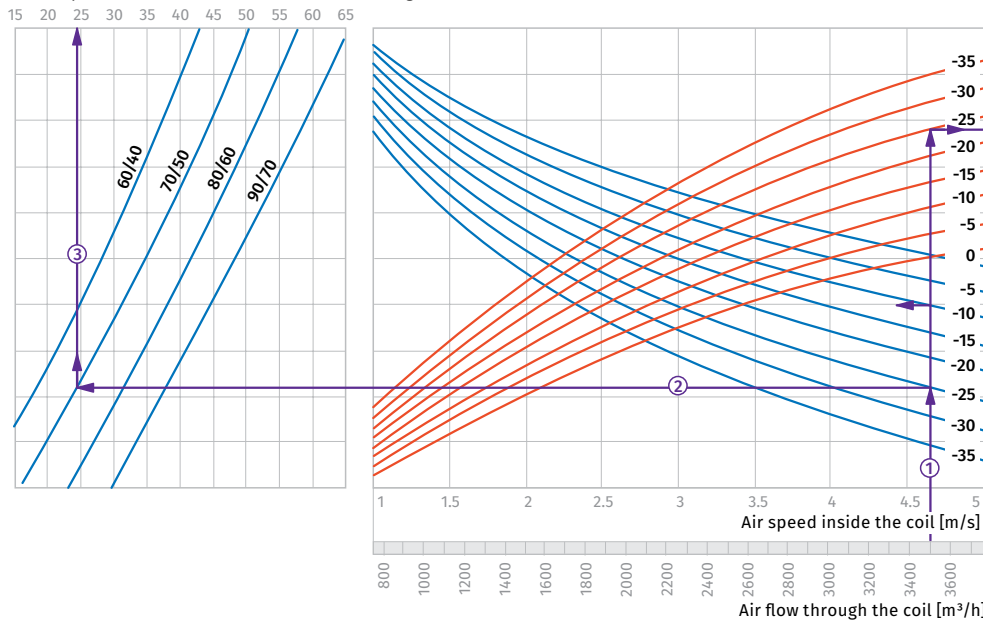

**How to use water heater diagrams.**

System Parameters: Air flow = 3500 m³/h.  
 Outside air temperature = -25 °C.  
 Water temperature (in/out) = +70/+50 °C.  
 The air flow is 3500 m³/h and the air speed in the heater is 4.65 m/s ①.

- To calculate the maximum air temperature find the intersection point of the air flow line ① with the rated outer temperature shown in blue line (e.g., -25 °C) and draw the line ② to the left until it crosses the water in/out temperature curve (e.g., +70/+50). From this point draw a vertical line to the supply air temperature downstream of the heater (+24 °C) ③.

- To calculate the heater power find the intersection point of the air flow ① with the rated winter temperature shown in red line (e.g., -25 °C) and draw the line ④ to the right until it crosses the water in/out temperature curve (e.g., +70/+50). From this point draw a vertical line to the heater power axis (68.0 kW) ⑤.

- To calculate the required water flow in the heater prolong this line ⑥ downwards to the water flow axis (0.84 l/s).
- To calculate the water pressure drop in the heater find the intersection point of the line ⑥ with the pressure loss curve and prolong the line ⑦ to the right on the water pressure drop axis (18.0 kPa).

**WKH 70x40-2**

Air temperature downstream of the water heating coils [°C]

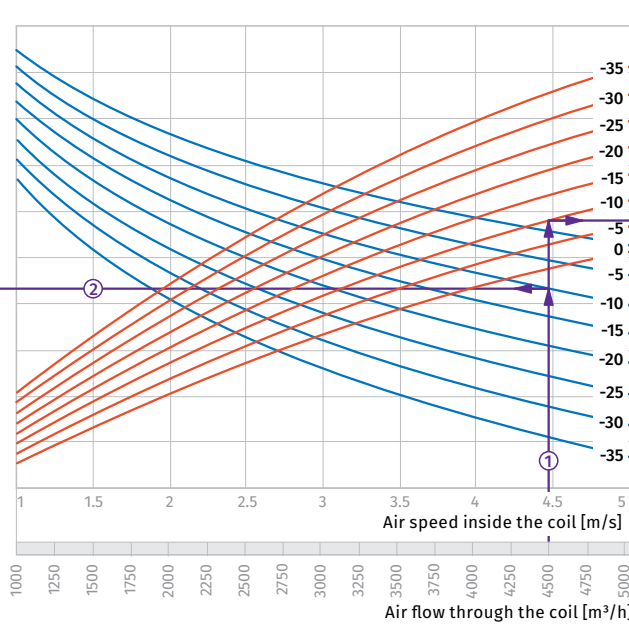
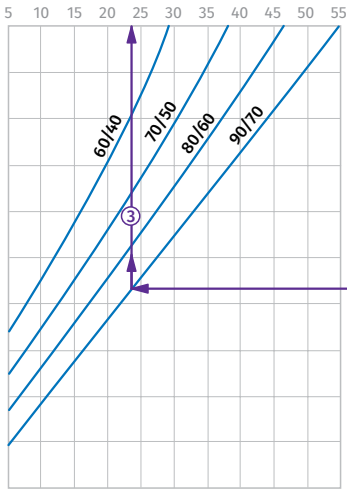

Coil heating capacity [kW]

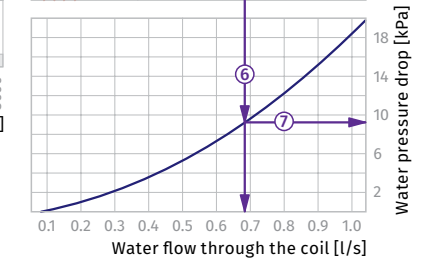
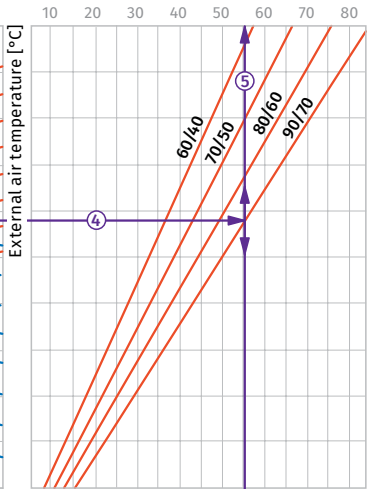

**How to use water heater diagrams.**

System Parameters: Air flow = 4500 m<sup>3</sup>/h.  
Outside air temperature = -10 °C.  
Water temperature (in/out) = +90/+70 °C.  
The air flow is 2500 m<sup>3</sup>/h and the air speed in the heater is 4.45 m/s ①.

- To calculate the maximum air temperature find the intersection point of the air flow line ① with the rated outer temperature shown in blue line (e.g., -10 °C) and draw the line ② to the left until it crosses the water in/out temperature curve (e.g., +90/+70). From this point draw a vertical line to the supply air temperature downstream of the heater (+24 °C) ③.

- To calculate the heater power find the intersection point of the air flow ① with the rated winter temperature shown in red line (e.g., -10 °C) and draw the line ④ to the right until it crosses the water in/out temperature curve (e.g., +90/+70). From this point draw a vertical line to the heater power axis (55.0 kW) ⑤.

- To calculate the required water flow in the heater prolong this line ⑥ downwards to the water flow axis (0.68 l/s).
- To calculate the water pressure drop in the heater find the intersection point of the line ⑥ with the pressure loss curve and prolong the line ⑦ to the right on the water pressure drop axis (9.2 kPa).

**WKH 70x40-3**

Air temperature downstream of the water heating coils [°C]

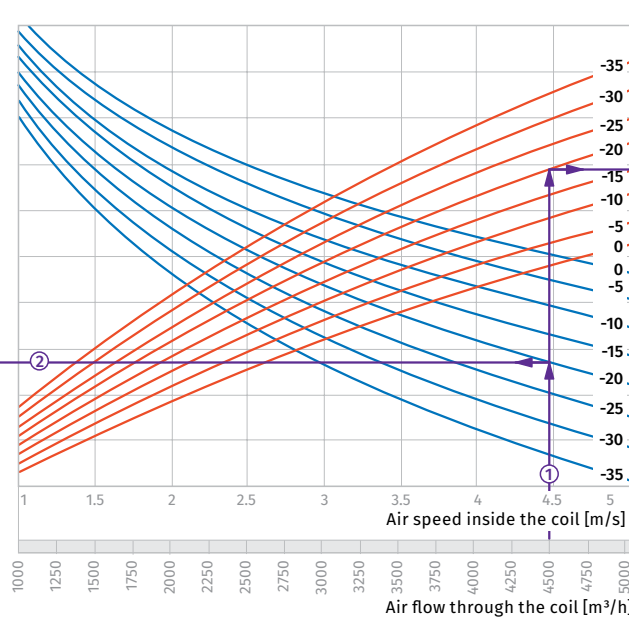
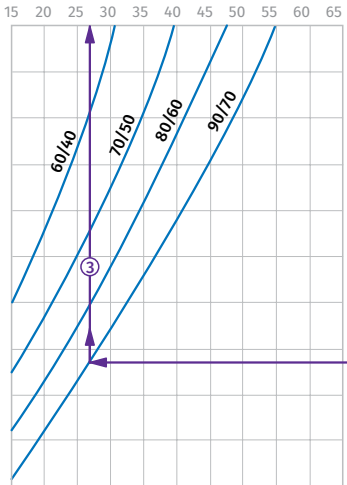

Coil heating capacity [kW]

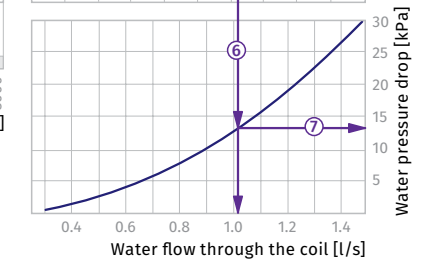
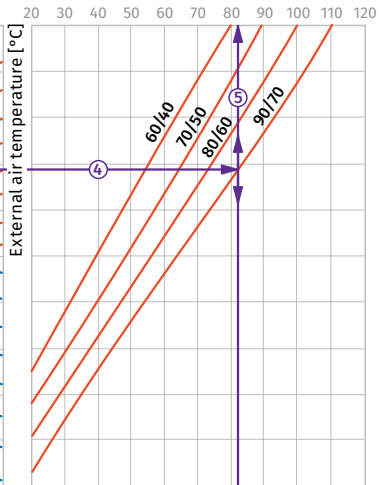

**How to use water heater diagrams.**

System Parameters: Air flow = 4500 m<sup>3</sup>/h.  
Outside air temperature = -20 °C.  
Water temperature (in/out) = +90/+70 °C.  
The air flow is 2500 m<sup>3</sup>/h and the air speed in the heater is 4.45 m/s ①.

- To calculate the maximum air temperature find the intersection point of the air flow line ① with the rated winter temperature shown in blue line (e.g., -20 °C) and draw the line ② to the left until it crosses the water in/out temperature curve (e.g., +90/+70). From this point draw a vertical line to the supply air temperature downstream of the heater (+27 °C) ③.

- To calculate the heater power find the intersection point of the air flow ① with the rated winter temperature shown in red line (e.g., -20 °C) and draw the line ④ to the right until it crosses the water in/out temperature curve (e.g., +90/+70). From this point draw a vertical line to the heater power axis (82.0 kW) ⑤.

- To calculate the required water flow in the heater prolong this line ⑥ downwards to the water flow axis (1.02 l/s).
- To calculate the water pressure drop in the heater find the intersection point of the line ⑥ with the pressure loss curve and prolong the line ⑦ to the right on the water pressure drop axis (13.0 kPa).

**WKH 80x50-2**

Air temperature downstream of the water heating coils [°C]

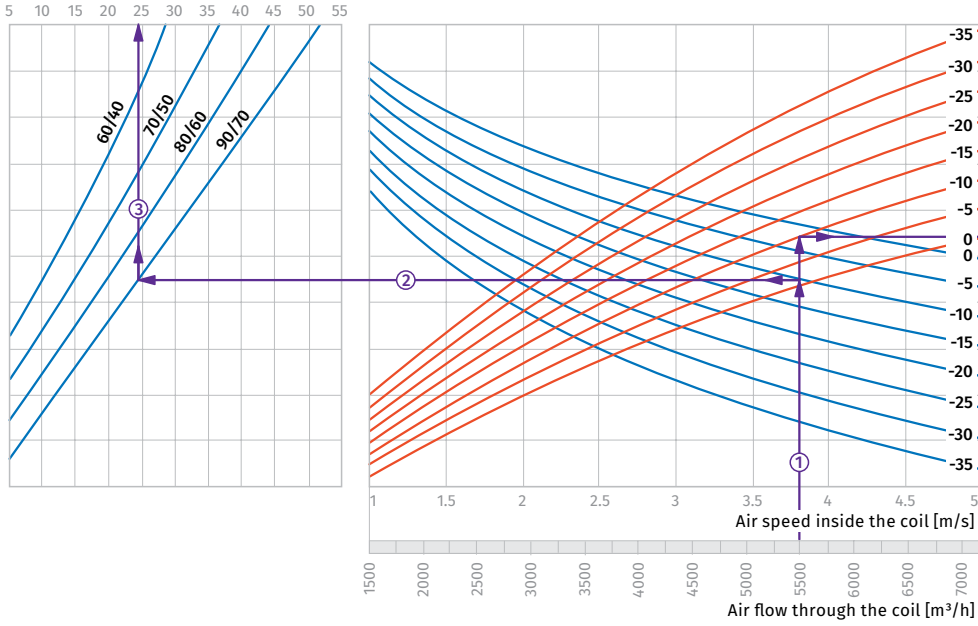

Coil heating capacity [kW]

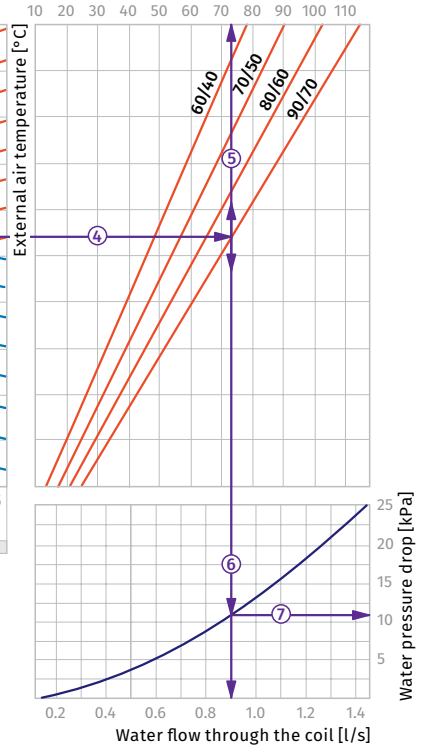

**How to use water heater diagrams.**

System Parameters: Air flow = 5500 m³/h.  
 Outside air temperature = -10 °C.  
 Water temperature (in/out) = +90/+70 °C.  
 The air flow is 5500 m³/h and the air speed in the heater is 3.8 m/s ①.

- To calculate the maximum air temperature find the intersection point of the air flow line ① with the rated outer temperature shown in blue line (e.g., -10 °C) and draw the line ② to the left until it crosses the water in/out temperature curve (e.g., +90/+70). From this point draw a vertical line to the supply air temperature downstream of the heater (+24.5 °C) ③.

- To calculate the heater power find the intersection point of the air flow ① with the rated winter temperature shown in red line (e.g., -10 °C) and draw the line ④ to the right until it crosses the water in/out temperature curve (e.g., +90/+70). From this point draw a vertical line to the heater power axis (73.0 kW) ⑤.

- To calculate the required water flow in the heater prolong this line ⑥ downwards to the water flow axis (0.9 l/s).
- To calculate the water pressure drop in the heater find the intersection point of the line ⑥ with the pressure loss curve and prolong the line ⑦ to the right on the water pressure drop axis (11.0 kPa).

**WKH 80x50-3**

Air temperature downstream of the water heating coils [°C]

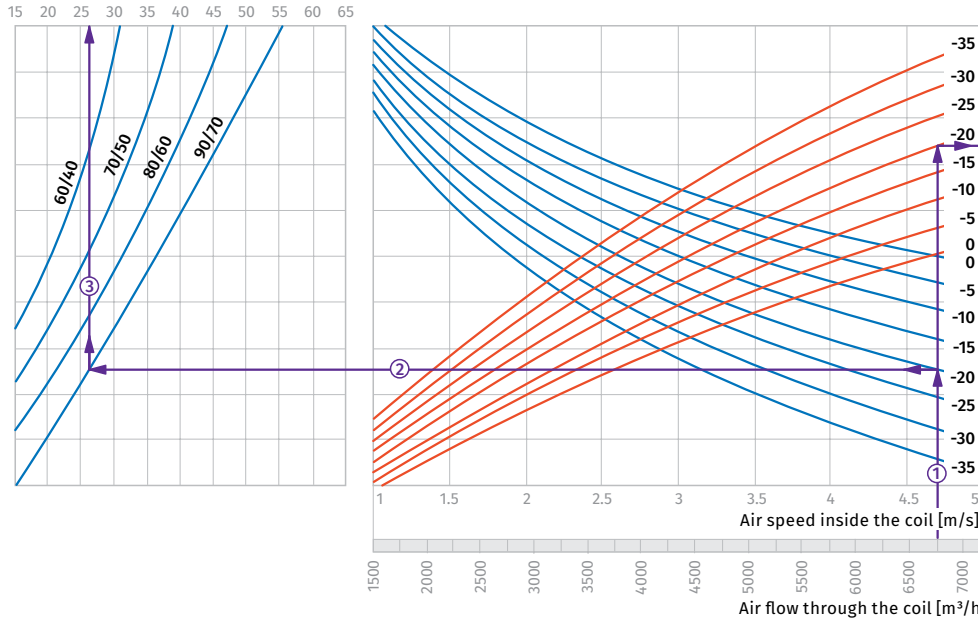

Coil heating capacity [kW]

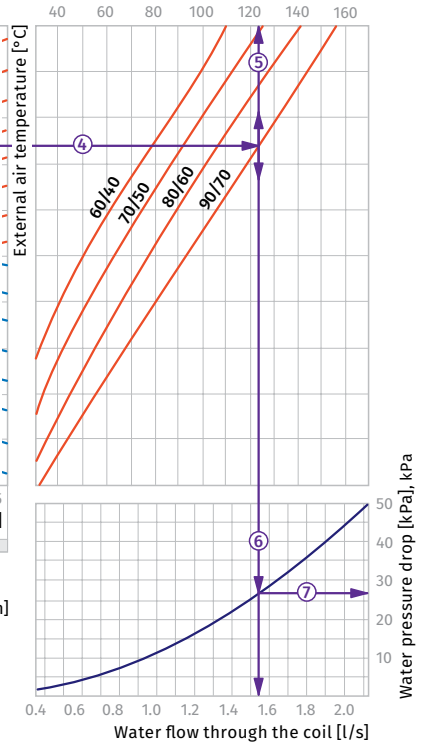

**How to use water heater diagrams.**

System Parameters: Air flow = 6750 m³/h.  
 Outside air temperature = -20 °C.  
 Water temperature (in/out) = +90/+70 °C.  
 The air flow is 6750 m³/h and the air speed in the heater is 4.7 m/s ①.

- To calculate the maximum air temperature find the intersection point of the air flow line ① with the rated outer temperature shown in blue line (e.g., -20 °C) and draw the line ② to the left until it crosses the water in/out temperature curve (e.g., +90/+70). From this point draw a vertical line to the supply air temperature downstream of the heater (+26 °C) ③.

- To calculate the heater power find the intersection point of the air flow ① with the rated winter temperature shown in red line (e.g., -20 °C) and draw the line ④ to the right until it crosses the water in/out temperature curve (e.g., +90/+70). From this point draw a vertical line to the heater power axis (123.0 kW) ⑤.

- To calculate the required water flow in the heater prolong this line ⑥ downwards to the water flow axis (1.54 l/s).
- To calculate the water pressure drop in the heater find the intersection point of the line ⑥ with the pressure loss curve and prolong the line ⑦ to the right on the water pressure drop axis (27.0 kPa).



**WKH 90x50-2**

Air temperature downstream of the water heating coils [°C]

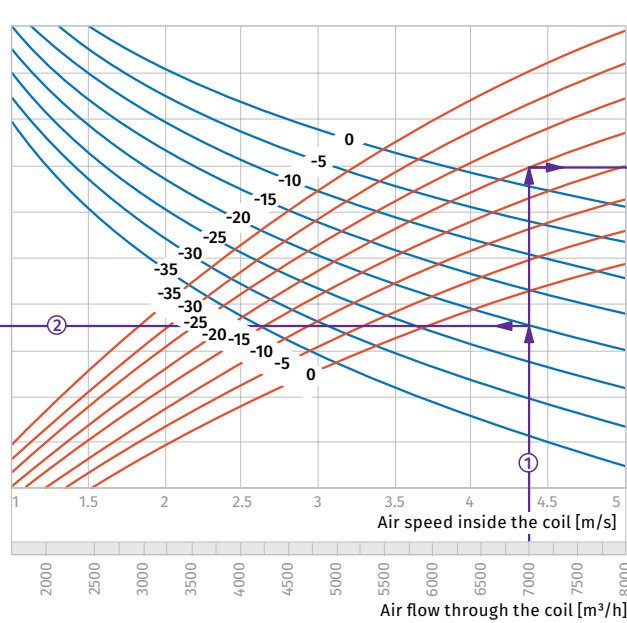
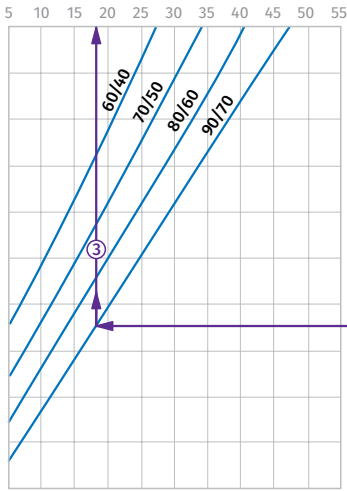

Coil heating capacity [kW]

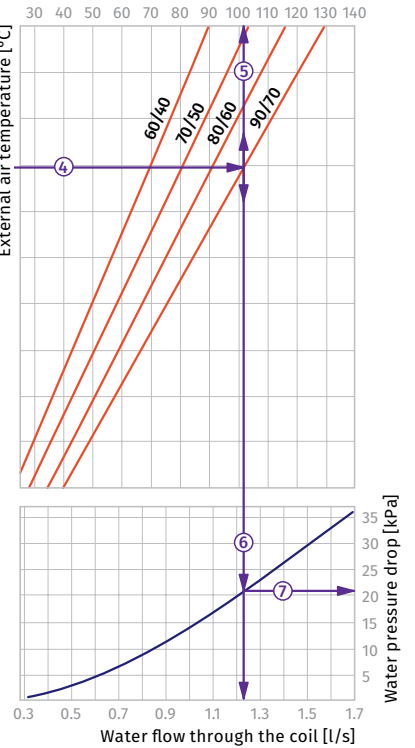

**How to use water heater diagrams.**

System Parameters: Air flow = 7000 m³/h.  
Outside air temperature = -20 °C.  
Water temperature (in/out) = +90/+70 °C.  
The air flow is 7000 m³/h and the air speed in the heater is 4.4 m/s ①.

- To calculate the maximum air temperature find the intersection point of the air flow line ① with the rated outer temperature shown in blue line (e.g., -20 °C) and draw the line ② to the left until it crosses the water in/out temperature curve (e.g., +90/+70). From this point draw a vertical line to the supply air temperature downstream of the heater (+18 °C) ③.

- To calculate the heater power find the intersection point of the air flow ① with the rated winter temperature shown in red line (e.g., -20 °C) and draw the line ④ to the right until it crosses the water in/out temperature curve (e.g., +90/+70). From this point draw a vertical line to the heater power axis (102.0 kW) ⑤.

- To calculate the required water flow in the heater prolong this line ⑥ downwards to the water flow axis (1.23 l/s).
- To calculate the water pressure drop in the heater find the intersection point of the line ⑥ with the pressure loss curve and prolong the line ⑦ to the right on the water pressure drop axis (21.0 kPa).

**WKH 90x50-3**

Air temperature after heater passage [°C]

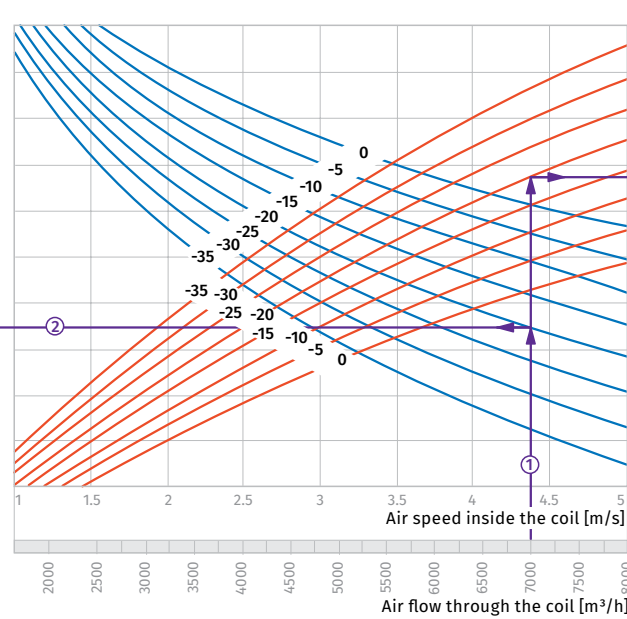
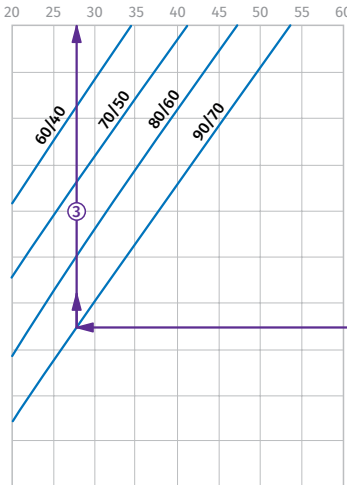

Coil heating capacity [kW]

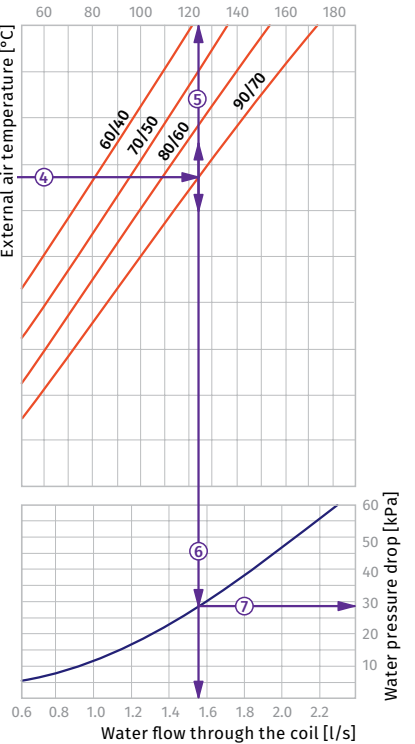

**How to use water heater diagrams.**

System Parameters: Air flow = 7000 m³/h.  
Outside air temperature = -20 °C.  
Water temperature (in/out) = +90/+70 °C.  
The air flow is 7000 m³/h and the air speed in the heater is 4.4 m/s ①.

- To calculate the maximum air temperature find the intersection point of the air flow line ① with the rated outer temperature shown in blue line (e.g., -20 °C) and draw the line ② to the left until it crosses the water in/out temperature curve (e.g., +90/+70). From this point draw a vertical line to the supply air temperature downstream of the heater (+28 °C) ③.

- To calculate the heater power find the intersection point of the air flow ① with the rated winter temperature shown in red line (e.g., -20 °C) and draw the line ④ to the right until it crosses the water in/out temperature curve (e.g., +90/+70). From this point draw a vertical line to the heater power axis (124.0 kW) ⑤.

- To calculate the required water flow in the heater prolong this line ⑥ downwards to the water flow axis (1.55 l/s).
- To calculate the water pressure drop in the heater find the intersection point of the line ⑥ with the pressure loss curve and prolong the line ⑦ to the right on the water pressure drop axis (28.0 kPa).

**WKH 100x50-2**

Air temperature downstream of the water heating coils [°C]

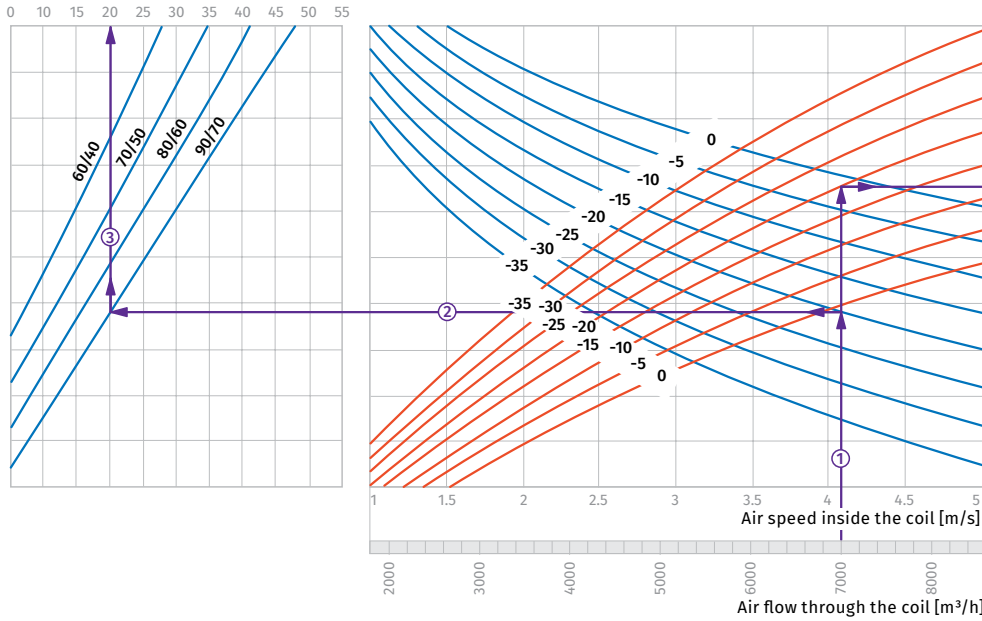

Coil heating capacity [kW]

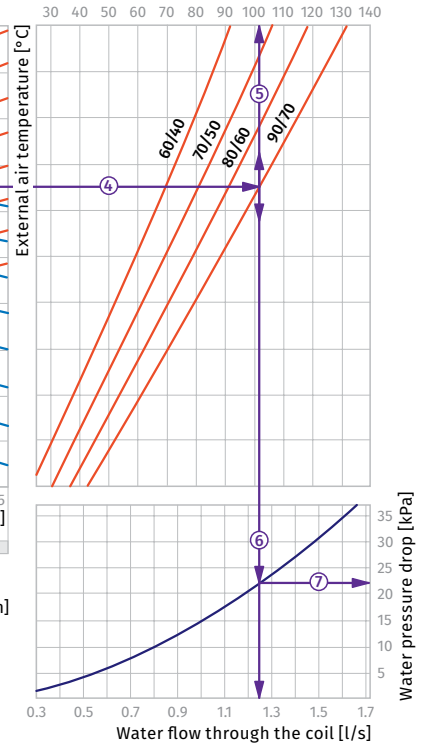

**How to use water heater diagrams.**

System Parameters: Air flow = 7000 m<sup>3</sup>/h.  
 Outside air temperature = -20 °C.  
 Water temperature (in/out) = +90/+70 °C.  
 The air flow is 7000 m<sup>3</sup>/h and the air speed in the heater is 4.1 m/s ①.

- To calculate the maximum air temperature find the intersection point of the air flow line ① with the rated outer temperature shown in blue line (e.g., -20 °C) and draw the line ② to the left until it crosses the water in/out temperature curve (e.g., +90/+70). From this point draw a vertical line to the supply air temperature downstream of the heater (+20 °C) ③.

- To calculate the heater power find the intersection point of the air flow ① with the rated winter temperature shown in red line (e.g., -20 °C) and draw the line ④ to the right until it crosses the water in/out temperature curve (e.g., +90/+70). From this point draw a vertical line to the heater power axis (101.0 kW) ⑤.

- To calculate the required water flow in the heater prolong this line ⑥ downwards to the water flow axis (1.25 l/s).
- To calculate the water pressure drop in the heater find the intersection point of the line ⑤ with the pressure loss curve and prolong the line ⑦ to the right on the water pressure drop axis (22.0 kPa).

**WKH 100x50-3**

Air temperature downstream of the water heating coils [°C]

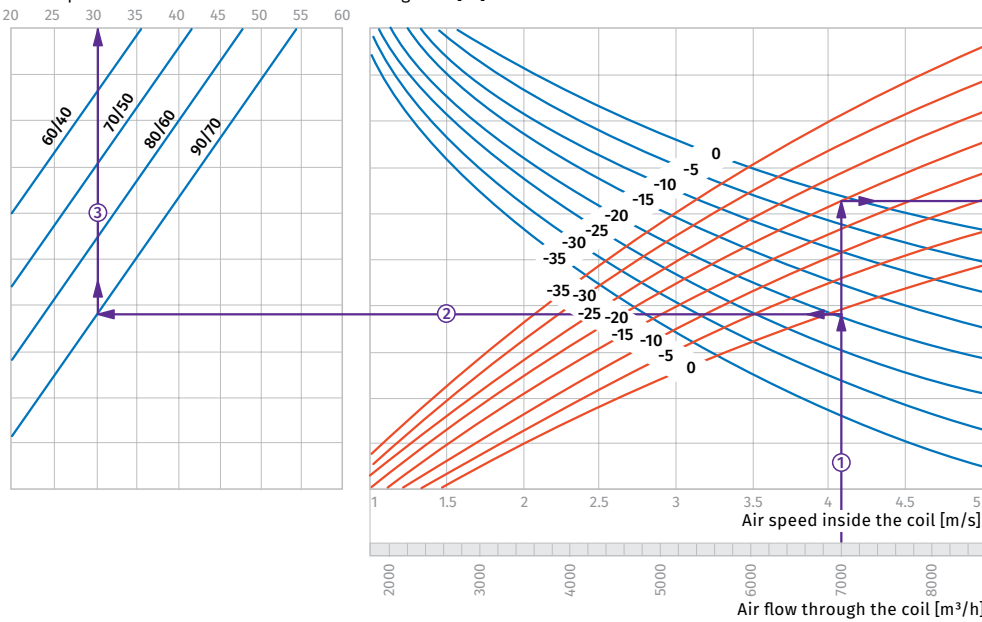

Coil heating capacity [kW]

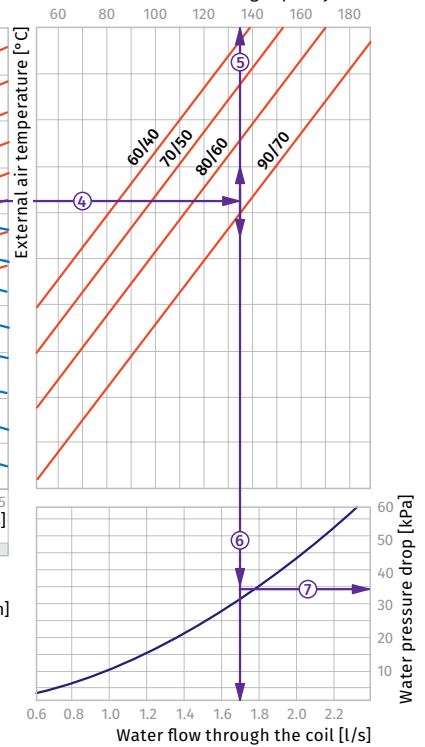

**How to use water heater diagrams.**

System Parameters: Air flow = 7000 m<sup>3</sup>/h.  
 Outside air temperature = -20 °C.  
 Water temperature (in/out) = +90/+70 °C.  
 The air flow is 7000 m<sup>3</sup>/h and the air speed in the heater is 4.1 m/s ①.

- To calculate the maximum air temperature find the intersection point of the air flow line ① with the rated outer temperature shown in blue line (e.g., -20 °C) and draw the line ② to the left until it crosses the water in/out temperature curve (e.g., +90/+70). From this point draw a vertical line to the supply air temperature downstream of the heater (+30 °C) ③.

- To calculate the heater power find the intersection point of the air flow ① with the rated winter temperature shown in red line (e.g., -20 °C) and draw the line ④ to the right until it crosses the water in/out temperature curve (e.g., +90/+70). From this point draw a vertical line to the heater power axis (135.0 kW) ⑤.

- To calculate the required water flow in the heater prolong this line ⑥ downwards to the water flow axis (1.7 l/s).
- To calculate the water pressure drop in the heater find the intersection point of the line ⑤ with the pressure loss curve and prolong the line ⑦ to the right on the water pressure drop axis (34.0 kPa).