

# WKH

## Duct water heaters for round ducts

### Features

- For warming up of supply air in ventilation systems installed in various premises.
- Suitable for installation in supply or air handling units to warm up the supply air flow.
- For indoor use only if water serves as a heat carrier. For outdoor features use antifreezing mixture (ethylene glycol solution).
- Compatible with Ø 100 to 315 mm round air ducts.



### Design

- Galvanized steel casing.
- Copper pipe manifold.
- Heat exchange surface made of aluminium plates.
- Airtight connection with air ducts due to rubber seals.
- Equipped with a nipple for the system deaeration.
- Outlet header is equipped with a spigot for installation of an immersion temperature sensor or freezing protection mechanism.
- Available in two- or four-row coil modifications.
- Suitable for operation at maximum operating pressure 1.6 MPa (16 bar) and maximum operating temperature +100 °C.

### Mounting

- Fixing to round ducts with clamps.
- Any mounting position that ensures the heater deaeration.
- Install a filter upstream to the heater to protect heating elements against dirt ingress.

- Install the heater in front or behind the fan. In case of mounting behind the fan ensure a distance of not less than two connecting diameters for air flow stabilization and keep the maximum permissible air temperature inside the fan.
- Connect the heater on counter-flow basis, otherwise its capacity drops by 5–15 %. All the nomographic charts are rated for counter-flow connection.
- For correct and safe heater operation an automatic control and protection system is recommended, including the following functions:
  - regulation of the heating capacity and temperature of the air heated up;
  - filter clogging control by a differential air pressure sensor;
  - ventilation system start-up with pre-heated heater;
  - use of air dampers fitted with a spring return actuator;
  - fan turns off in case of freezing danger for the heater.

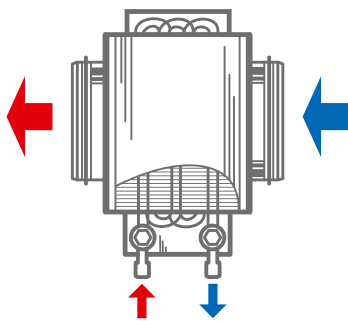

Connection against air flow

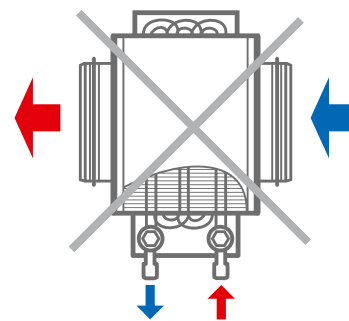

Connection along air flow

### Designation key

Series	Connected air duct diameter [mm]	Number of water (glycol) coil rows
WKH	100; 125; 150; 160; 200; 250; 315	- 2; 4

### Overall dimensions [mm]

Model	D	B	H	H2	L	L1	L2	L3	K	Number of water coil rows	Weight [kg]
WKH 100-2	100	350	240	150	300	82	43	220	G 3/4"	2	4.5
WKH 100-4	100	350	240	150	300	78	65	220	G 3/4"	4	5.2
WKH 125-2	125	350	240	150	300	82	43	220	G 3/4"	2	4.5
WKH 125-4	125	350	240	150	300	78	65	220	G 3/4"	4	5.2
WKH 150-2	150	400	290	200	300	82	43	220	G 3/4"	2	7.5
WKH 150-4	150	400	290	200	300	78	65	220	G 3/4"	4	8.2
WKH 160-2	160	400	290	200	300	82	43	220	G 3/4"	2	7.5
WKH 160-4	160	400	290	200	300	78	65	220	G 3/4"	4	8.2
WKH 200-2	200	400	290	200	300	82	43	220	G 3/4"	2	7.5
WKH 200-4	200	400	290	200	300	78	65	220	G 3/4"	4	8.2
WKH 250-2	250	470	360	270	350	107	43	270	G 1"	2	10.3
WKH 250-4	250	470	360	270	350	103	65	270	G 1"	4	10.8
WKH 315-2	315	550	440	350	450	157	43	370	G 1"	2	11.5
WKH 315-4	315	550	440	350	450	153	65	370	G 1"	4	12.2

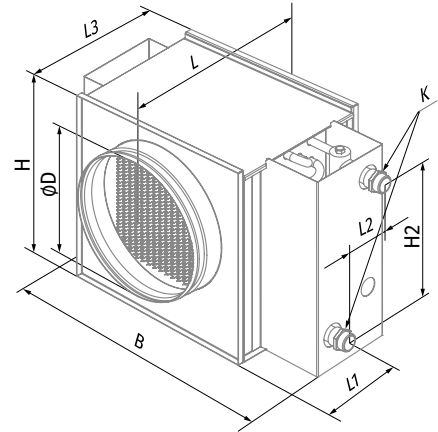

### WKH ROUND HEATERS

Air pressure loss for water heaters WKH

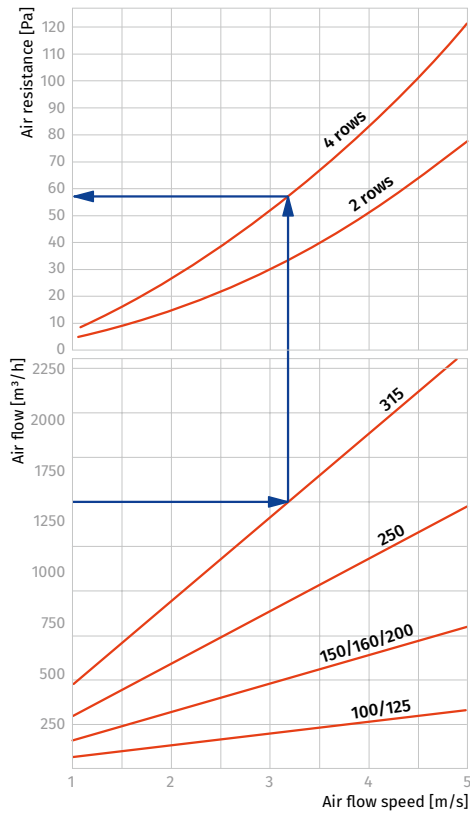

**Water heaters calculation diagram**

**WKH 100-2 / WKH 125-2**

Air temperature downstream of the water heating coils [°C]

5 10 15 20 25 30 35 40 45 50 55

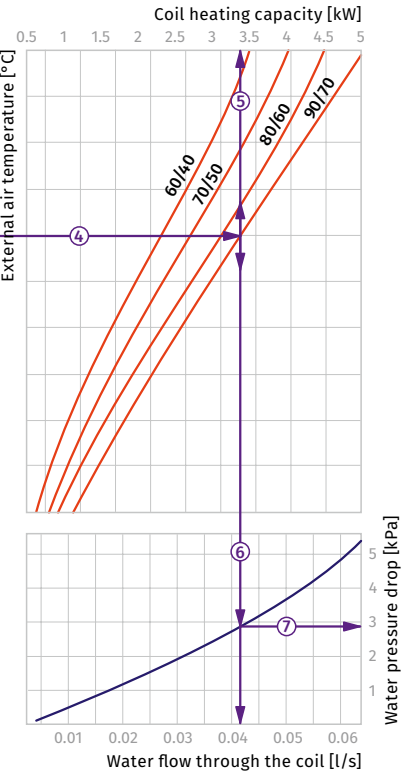
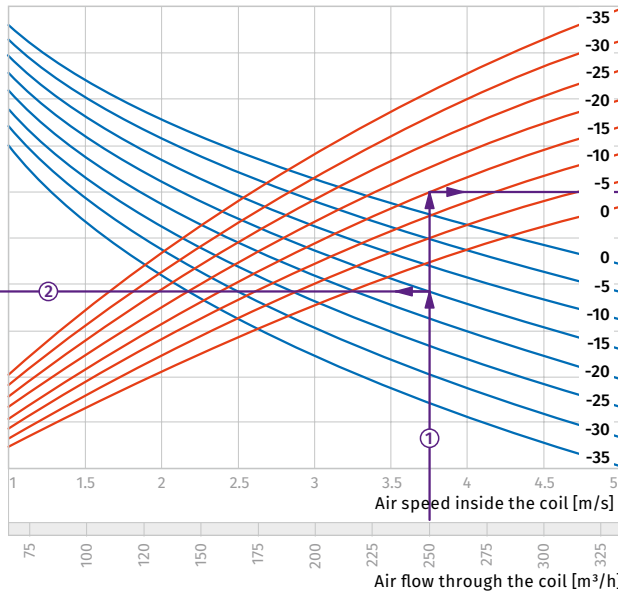
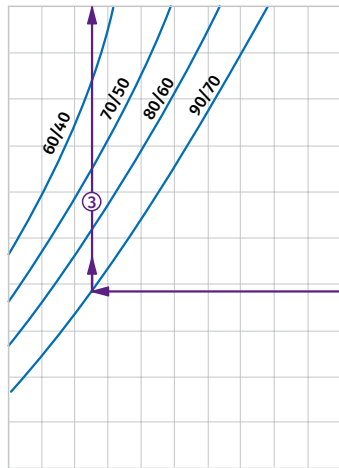

**How to use water heater diagrams.**

System Parameters: Air flow = 250 m<sup>3</sup>/h.  
Outside air temperature = -15 °C.  
Water temperature (in/out) = +90/+70 °C.  
The air flow is 250 m<sup>3</sup>/h and the air speed in the heater is 3.75 m/s ①.

- To calculate the maximum air temperature find the intersection point of the air flow line ① with the rated outer temperature shown in blue line (e.g., -15 °C) and draw the line ② to the left until it crosses the water in/out temperature curve (e.g., +90/+70). From this point draw a vertical line to the supply air temperature downstream of the heater (+17.50 °C) ③.

- To calculate the heater power find the intersection point of the air flow ① with the rated winter temperature shown in red line (e.g., -15 °C) and draw the line ④ to the right until it crosses the water in/out temperature curve (e.g., +90/+70). From this point draw a vertical line to the heater power axis (3.25 kW) ⑤.

- To calculate the required water flow in the heater prolong this line ⑥ downwards to the water flow axis (0.042 l/s).
- To calculate the water pressure drop in the heater find the intersection point of the line ⑥ with the pressure loss curve and prolong the line ⑦ to the right on the water pressure drop axis (2.9 kPa).

**WKH 100-4 / WKH 125-4**

Air temperature downstream of the water heating coils [°C]

15 20 25 30 35 40 45 50 55 60 65

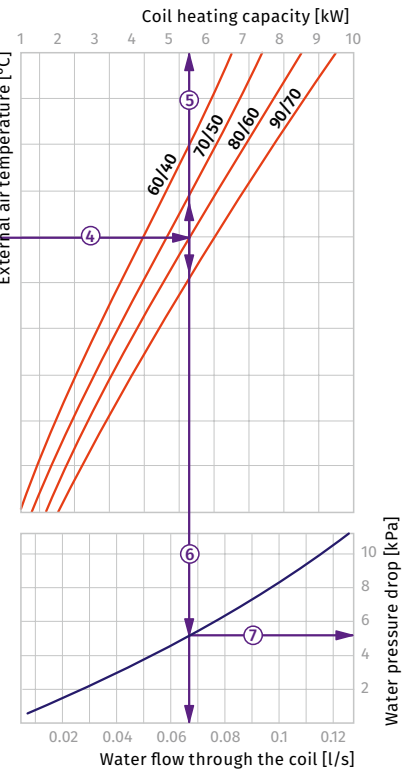
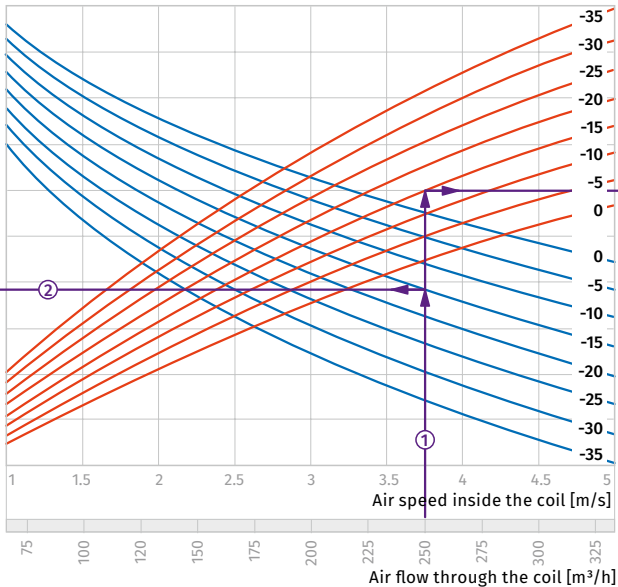
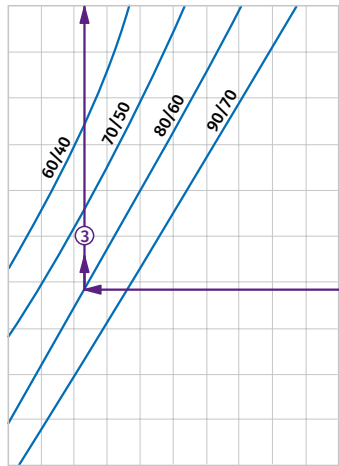

**How to use water heater diagrams.**

System Parameters: Air flow = 250 m<sup>3</sup>/h.  
Outside air temperature = -15 °C.  
Water temperature (in/out) = +80/+60 °C.  
The air flow is 250 m<sup>3</sup>/h and the air speed in the heater is 3.75 m/s ①.

- To calculate the maximum air temperature find the intersection point of the air flow line ① with the rated outer temperature shown in blue line (e.g., -15 °C) and draw the line ② to the left until it crosses the water in/out temperature curve (e.g., +80/+60). From this point draw a vertical line to the supply air temperature downstream of the heater (+27 °C) ③.

- To calculate the heater power find the intersection point of the air flow ① with the rated winter temperature shown in red line (e.g., -15 °C) and draw the line ④ to the right until it crosses the water in/out temperature curve (e.g., +80/+60). From this point draw a vertical line to the heater power axis (5.2 kW) ⑤.

- To calculate the required water flow in the heater prolong this line ⑥ downwards to the water flow axis (0.067 l/s).
- To calculate the water pressure drop in the heater find the intersection point of the line ⑥ with the pressure loss curve and prolong the line ⑦ to the right on the water pressure drop axis (5.2 kPa).

**WKH 150-2 / WKH 160-2 / WKH 200-2**

Air temperature downstream of the water heating coils [°C]

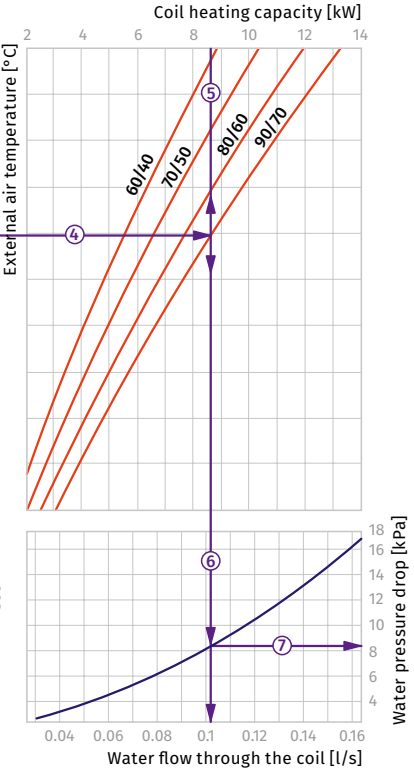
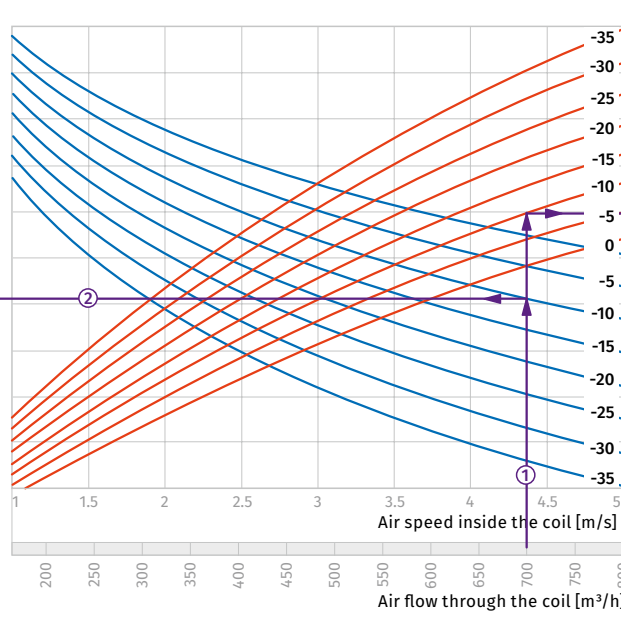
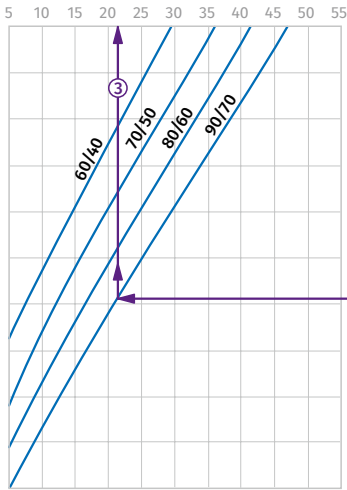

**How to use water heater diagrams.**

System Parameters: Air flow = 700 m<sup>3</sup>/h.  
 Outside air temperature = -10 °C.  
 Water temperature (in/out) = +90/+70 °C.  
 The air flow is 700 m<sup>3</sup>/h and the air speed in the heater is 4.4 m/s ①.

- To calculate the maximum air temperature find the intersection point of the air flow line ① with the rated outer temperature shown in blue line (e.g., -10 °C) and draw the line ② to the left until it crosses the water in/out temperature curve (e.g., +90/+70). From this point draw a vertical line to the supply air temperature downstream of the heater (+21 °C) ③.

- To calculate the heater power find the intersection point of the air flow ① with the rated winter temperature shown in red line (e.g., -10 °C) and draw the line ④ to the right until it crosses the water in/out temperature curve (e.g., +90/+70). From this point draw a vertical line to the heater power axis (8.6 kW) ⑤.

- To calculate the required water flow in the heater prolong this line ⑥ downwards to the water flow axis (0.11 l/s).
- To calculate the water pressure drop in the heater find the intersection point of the line ⑥ with the pressure loss curve and prolong the line ⑦ to the right on the water pressure drop axis (8.2 kPa).

**WKH 150-4 / WKH 160-4 / WKH 200-4**

Air temperature downstream of the water heating coils [°C]

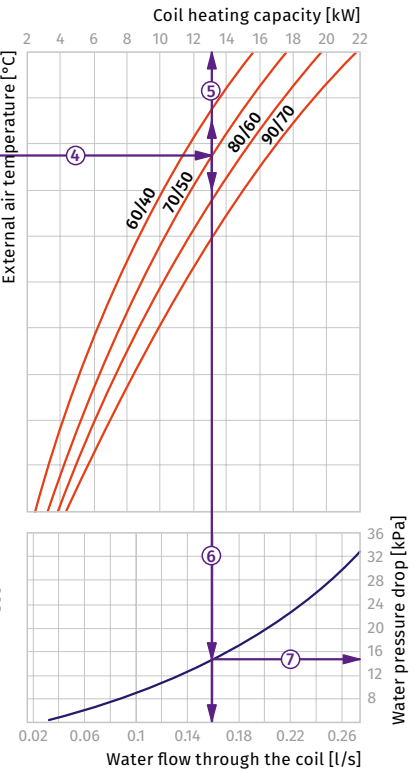
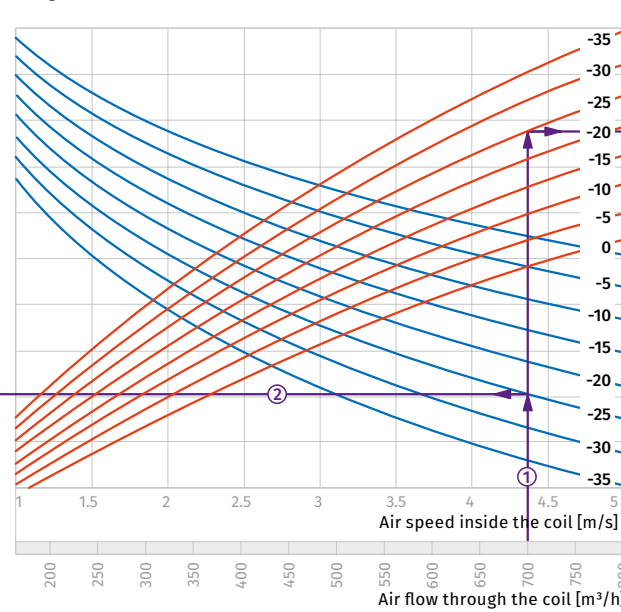
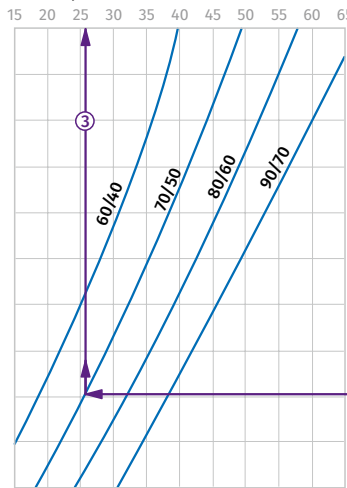

**How to use water heater diagrams.**

System Parameters: Air flow = 700 m<sup>3</sup>/h.  
 Outside air temperature = -25 °C.  
 Water temperature (in/out) = +70/+50 °C.  
 The air flow is 700 m<sup>3</sup>/h and the air speed in the heater is 4.4 m/s ①.

- To calculate the maximum air temperature find the intersection point of the air flow line ① with the rated outer temperature shown in blue line (e.g., -25 °C) and draw the line ② to the left until it crosses the water in/out temperature curve (e.g., +70/+50). From this point draw a vertical line to the supply air temperature downstream of the heater (+26 °C) ③.

- To calculate the heater power find the intersection point of the air flow ① with the rated winter temperature shown in red line (e.g., -25 °C) and draw the line ④ to the right until it crosses the water in/out temperature curve (e.g., +70/+50). From this point draw a vertical line to the heater power axis (13.0 kW) ⑤.

- To calculate the required water flow in the heater prolong this line ⑥ downwards to the water flow axis (0.16 l/s).
- To calculate the water pressure drop in the heater find the intersection point of the line ⑥ with the pressure loss curve and prolong the line ⑦ to the right on the water pressure drop axis (15 kPa).

**WKH 250-2**

Air temperature downstream of the water heating coils [°C]

5 10 15 20 25 30 35 40 45 50 55

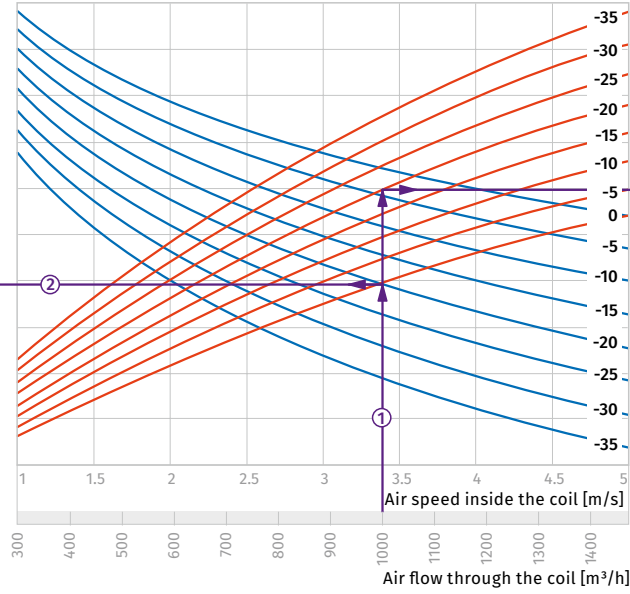
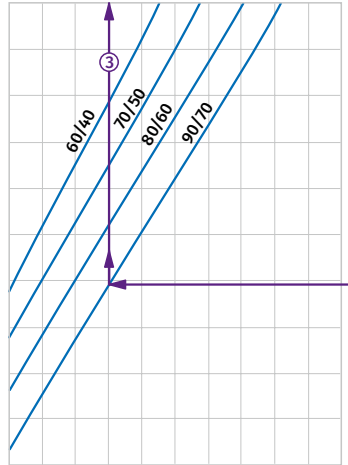

Coil heating capacity [kW]

2 4 6 8 10 12 14 16 18 20 22

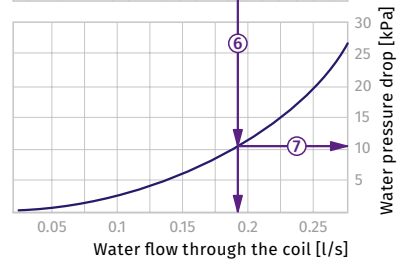
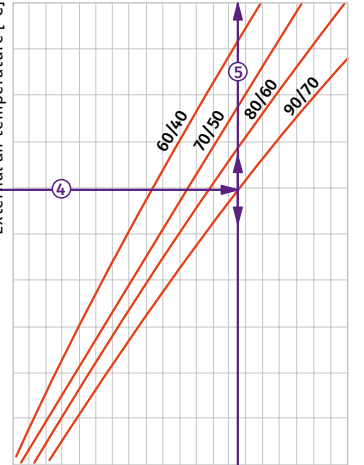

**How to use water heater diagrams.**

System Parameters: Air flow = 1000 m<sup>3</sup>/h.  
Outside air temperature = -20 °C.  
Water temperature (in/out) = +90/+70 °C.  
The air flow is 1000 m<sup>3</sup>/h and the air speed in the heater is 3.4 m/s ①.

- To calculate the maximum air temperature find the intersection point of the air flow line ① with the rated outer temperature shown in blue line (e.g., -20 °C) and draw the line ② to the left until it crosses the water in/out temperature curve (e.g., +90/+70). From this point draw a vertical line to the supply air temperature downstream of the heater (+20 °C) ③.

- To calculate the heater power find the intersection point of the air flow ① with the rated winter temperature shown in red line (e.g., -20 °C) and draw the line ④ to the right until it crosses the water in/out temperature curve (e.g., +90/+70). From this point draw a vertical line to the heater power axis (15.5 kW) ⑤.

- To calculate the required water flow in the heater prolong this line ⑥ downwards to the water flow axis (0.19 l/s).
- To calculate the water pressure drop in the heater find the intersection point of the line ⑥ with the pressure loss curve and prolong the line ⑦ to the right on the water pressure drop axis (11.0 kPa).

**WKH 250-4**

Air temperature downstream of the water heating coils [°C]

15 20 25 30 35 40 45 50 55 60 65

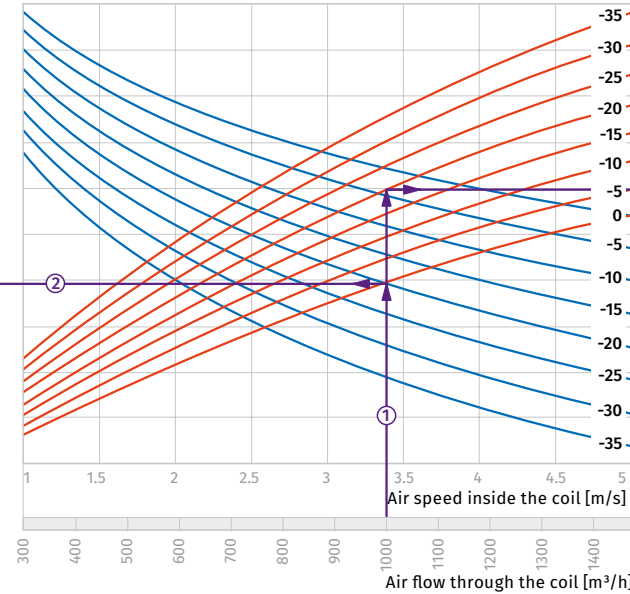
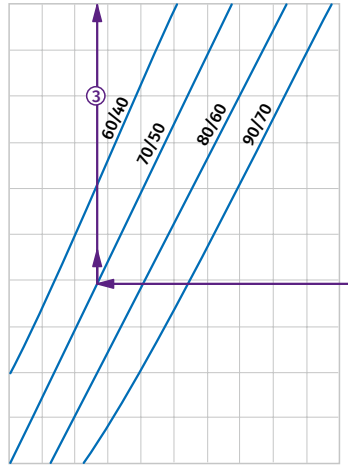

Coil heating capacity [kW]

0 4 8 12 16 20 24 28 32 36 40

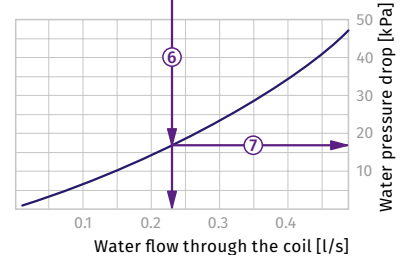
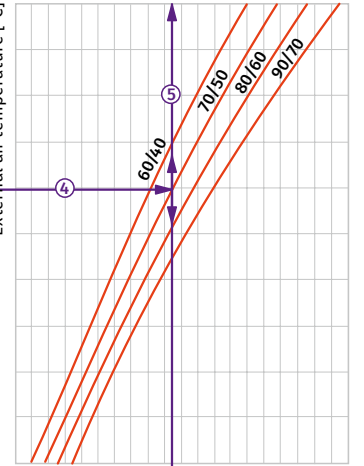

**How to use water heater diagrams.**

System Parameters: Air flow = 1000 m<sup>3</sup>/h.  
Outside air temperature = -20 °C.  
Water temperature (in/out) = +70/+50 °C.  
The air flow is 1000 m<sup>3</sup>/h and the air speed in the heater is 3.4 m/s ①.

- To calculate the maximum air temperature find the intersection point of the air flow line ① with the rated outer temperature shown in blue line (e.g., -20 °C) and draw the line ② to the left until it crosses the water in/out temperature curve (e.g., +70/+50). From this point draw a vertical line to the supply air temperature downstream of the heater (+28 °C) ③.

- To calculate the heater power find the intersection point of the air flow ① with the rated winter temperature shown in red line (e.g., -20 °C) and draw the line ④ to the right until it crosses the water in/out temperature curve (e.g., +70/+50). From this point draw a vertical line to the heater power axis (19.0 kW) ⑤.

- To calculate the required water flow in the heater prolong this line ⑥ downwards to the water flow axis (0.23 l/s).
- To calculate the water pressure drop in the heater find the intersection point of the line ⑥ with the pressure loss curve and prolong the line ⑦ to the right on the water pressure drop axis (17.0 kPa).

**WKH 315-2**

Air temperature downstream of the water heating coils [°C]

5 10 15 20 25 30 35 40 45 50 55

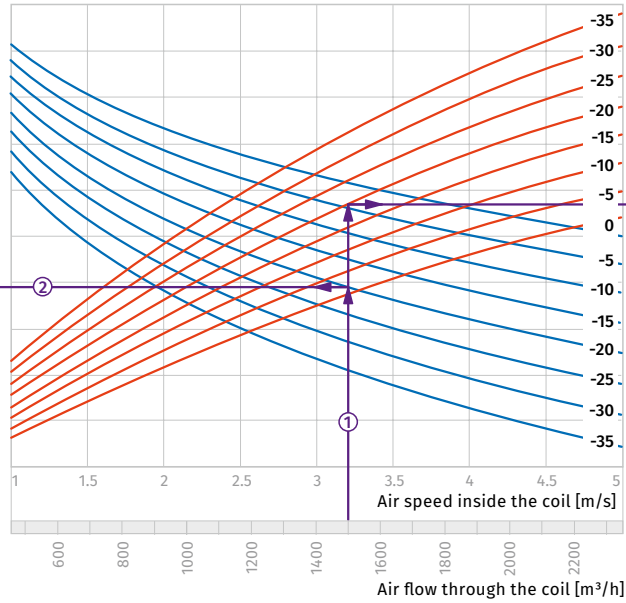
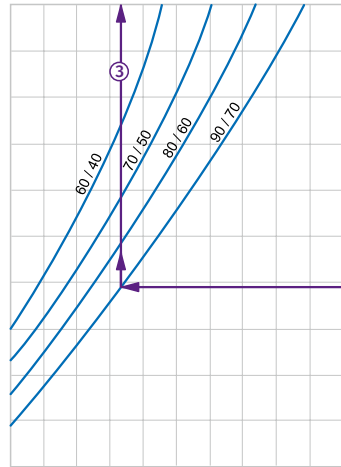

Coil heating capacity [kW]

8 12 16 20 24 28 32 36

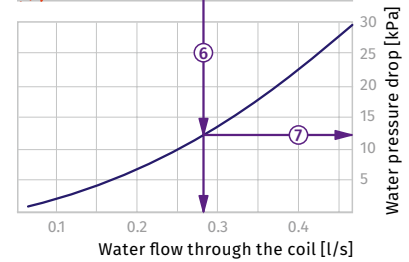
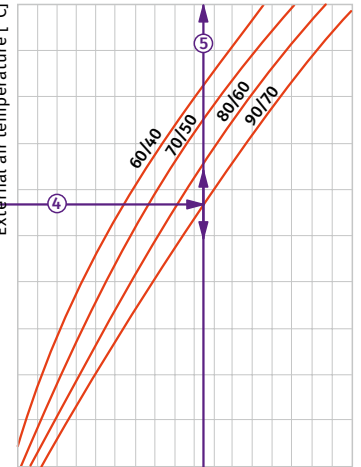

**How to use water heater diagrams.**

System Parameters: Air flow = 1500 m<sup>3</sup>/h.  
 Outside air temperature = -20 °C.  
 Water temperature (in/out) = +90/+70 °C.  
 The air flow is 1000 m<sup>3</sup>/h and the air speed in the heater is 3.2 m/s ①.

- To calculate the maximum air temperature find the intersection point of the air flow line ① with the rated outer temperature shown in blue line (e.g., -20 °C) and draw the line ② to the left until it crosses the water in/out temperature curve (e.g., +90/+70). From this point draw a vertical line to the supply air temperature downstream of the heater (+21 °C) ③.

- To calculate the heater power find the intersection point of the air flow ① with the rated winter temperature shown in red line (e.g., -20 °C) and draw the line ④ to the right until it crosses the water in/out temperature curve (e.g., +90/+70). From this point draw a vertical line to the heater power axis (23.0 kW) ⑤.

- To calculate the required water flow in the heater prolong this line ⑥ downwards to the water flow axis (0.28 l/s).
- To calculate the water pressure drop in the heater find the intersection point of the line ⑥ with the pressure loss curve and prolong the line ⑦ to the right on the water pressure drop axis (12.5 kPa).

**WKH 315-4**

Air temperature downstream of the water heating coils [°C]

15 20 25 30 35 40 45 50 55 60 65

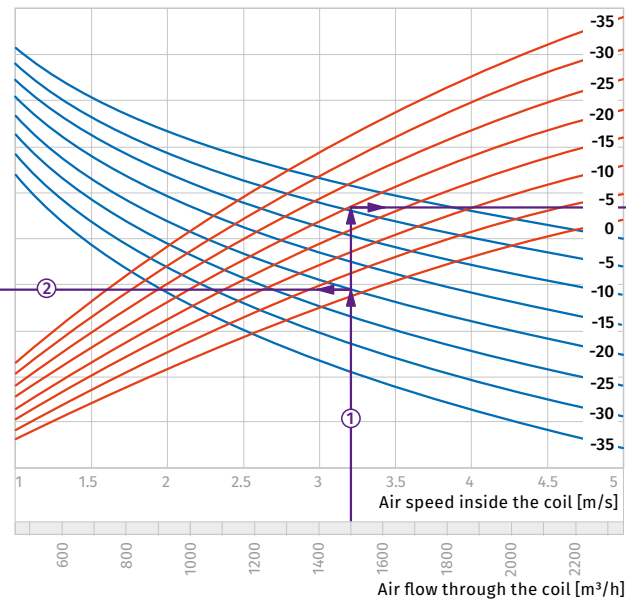
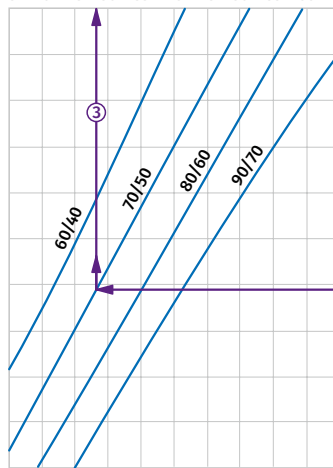

Coil heating capacity [kW]

0 10 20 30 40 50

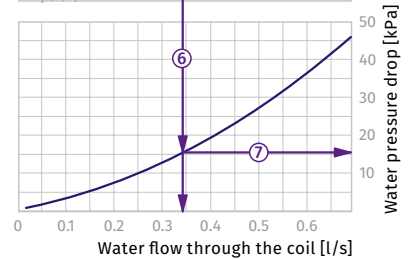
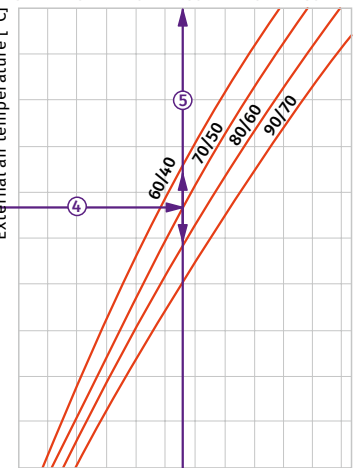

**How to use water heater diagrams.**

System Parameters: Air flow = 1500 m<sup>3</sup>/h.  
 Outside air temperature = -20 °C.  
 Water temperature (in/out) = +70/+50 °C.  
 The air flow is 1000 m<sup>3</sup>/h and the air speed in the heater is 3.2 m/s ①.

- To calculate the maximum air temperature find the intersection point of the air flow line ① with the rated outer temperature shown in blue line (e.g., -20 °C) and draw the line ② to the left until it crosses the water in/out temperature curve (e.g., +70/+50). From this point draw a vertical line to the supply air temperature downstream of the heater (+28 °C) ③.

- To calculate the heater power find the intersection point of the air flow ① with the rated winter temperature shown in red line (e.g., -20 °C) and draw the line ④ to the right until it crosses the water in/out temperature curve (e.g., +70/+50). From this point draw a vertical line to the heater power axis (28.0 kW) ⑤.

- To calculate the required water flow in the heater prolong this line ⑥ downwards to the water flow axis (0.34 l/s).
- To calculate the water pressure drop in the heater find the intersection point of the line ⑥ with the pressure loss curve and prolong the line ⑦ to the right on the water pressure drop axis (16.0 kPa).