

WMG

Water mixing unit

Features

- Smooth heating medium flow regulation and supply air set temperature maintaining in ventilation systems with water heating or cooling coils.
- Compatible with the WKH duct water heating coils and the KWK duct cooling coils.
- Compatible with all water heating or cooling coils installed in BLAUBOX supply units and KOMFORT air handling units.



Design

- The water mixing unit consists a circulation pump, a three-way electrically actuated heat medium control valve and a recirculation pipe.
- The three-way valve is designed for smooth mixing of the heat medium stream from the heating (cooling) system and the return heat medium in a required proportion to regulate the heat medium temperature supplied to the water heating or cooling coils.
- The three-way way is actuated with a control 0-10 V signal from the ventilation control system.
- The mixing unit is rated for heat medium operating pressure in the mixing set 10 bar.

Connection to water circuit

- Connection of the mixing unit to the water heating or cooling coils and to the water heating/cooling network through the pipes or flexible hoses of respective diameter, refer to the technical data table.
- In case of applying flexible hoses the mixing unit must be rigidly fixed.
- While installing the mixing unit the motor shaft must be installed horizontally. No mechanical loads from the pipes are allowed.

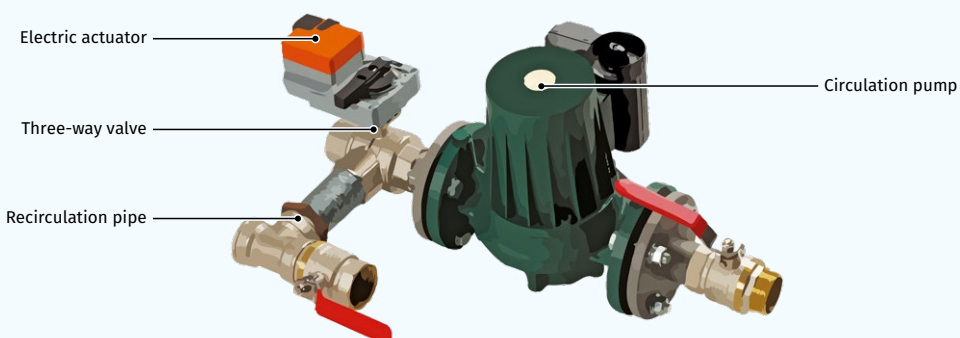

Designation key

Series	Connected spigot diameter [in]	Heat medium transmission factor (Kvs)
WMG	3/4; 1; 1 1/4; 1 1/2; 2	4; 6; 10; 16; 25; 40

Overall dimensions [mm]

Model	B	H	H1	L
WMG 3/4-4	150	290	180	460
WMG 3/4-6	150	290	180	460
WMG 1-6	175	320	210	490
WMG 1-10	175	320	210	490
WMG 1 1/4-10	175	355	240	500
WMG 1 1/4-16	175	355	240	500
WMG 1 1/2-16	266	420	255	610
WMG 1 1/2-25	266	420	255	610
WMG 2-25	312	474	290	660
WMG 2-40	312	474	290	660

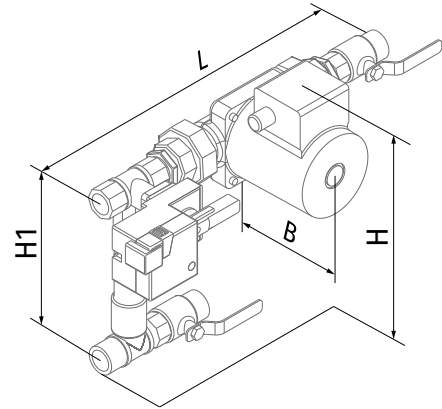

Recommended connection to water network

- T1 and T2: heat medium supply and return pipeline
- P1 and P2: water pressure gauges for supply and return pipes
- 1: mixing unit
- 2: water heater
- 3: electrically actuated three-way valve
- 4: circulation pump
- 5: shut-off valve
- 6: supply and return pipes from the heat distribution system to the water heater
- 7: non-return valve
- 8: balancing valve
- 9: coarse filter

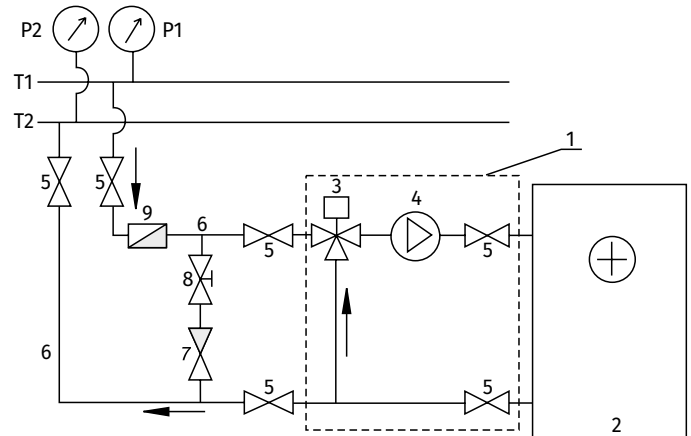

Technical data

Parameters	WMG 3/4-4	WMG 3/4-6	WMG 1-6	WMG 1-10	WMG 1 1/4-10	WMG 1 1/4-16	WMG 1 1/2-16	WMG 1 1/2-25	WMG 2-25	WMG 2-40
Circulation pump	DAB VA65/180		DAB A50/180XM		DAB A56/180XM		DAB BPH 120/250.40M		DAB BPH 120/280.50T	
Three-way valve control way	0...10 V	0...10 V	0...10 V	0...10 V	0...10 V	0...10 V	0...10 V	0...10 V	0...10 V	0...10 V
Electrically actuated three-way valve	R317	R318	R322	R323	R329	R331	R338	R339G	R348	R349G
Three-way valve actuator Belimo	LR24A-SR	LR24A-SR	LR24A-SR	LR24A-SR	LR24A-SR	LR24A-SR	NR24A-SR	SR24A-SR	NR24A-SR	SR24A-SR
Connection type	Threaded connection						Flanged connection			
Three-way valve nominal diameter	DN 20	DN 20	DN 25	DN 25	DN 32	DN 32	DN 40	DN 40	DN 50	DN 50
Three-way valve heat medium transmission factor (Kvs*)	4	6.3	6.3	10	10	16	16	25	25	40
Max. mixing unit flow capacity [m³/h]	2.3	3.0	4.1	6.0	6.8	9.0	11.0	14.0	21.0	27.0
Developed head [kPa]	57	57	57	57	62	62	110	110	115	115
Connected spigot diameter	3/4"	3/4"	1"	1"	1 1/4"	1 1/4"	1 1/2"	1 1/2"	2"	2"
Transported heat medium temperature [°C]	-10...+110	-10...+110	-10...+110	-10...+110	-10...+110	-10...+110	-10...+120	-10...+120	-10...+120	-10...+120
Max. glycol content in the transported heat medium [%]	30	30	30	30	30	30	30	30	30	30
Number of pump speeds	3	3	3	3	3	3	3	3	3	3
Phase / Pump supply voltage / 50 Hz [V]	1 ~ 230	1 ~ 230	1 ~ 230	1 ~ 230	1 ~ 230	1 ~ 230	1 ~ 230	1 ~ 230	3 ~ 400	3 ~ 400
Max. pump power [W]	78	78	184	184	271	271	510	510	898	898
Weight [kg]	4.1	4.1	6.8	6.8	7.4	7.4	23.0	23.0	31.0	31.0

Heat medium transmission factor $K_{vs} = \frac{V_{100}}{\sqrt{\frac{\Delta p_{V_{100}}}{100}}}$, where $\Delta p_{V_{100}}$ – pressure loss when the heat medium valve is fully opened.
 V_{100} – rated heat medium flow at $\Delta p_{V_{100}}$.

Mixing unit calculation diagram

Mixing unit selection: find the required heat medium flow through the heating (cooling) unit as well as heat medium pressure drop (available head). These parameters are determined using the heating or cooling unit calculation diagram for each water heating or cooling unit.

